

Transistor brukt som forsterker

Vi ser på Småsignalmodeller

Vi har sett hvordan vi vha. en emittermotstand kan stabilisere forsterkerens arbeidspunkt
- Alle betraktninger så langt er gjort med en DC – modell av forsterkeren. (En statisk beregningsmodell)

Men hvordan virker forsterkeren for små signaler?

Vi erstatter det vanlige transistorsymbolet med en småsignalmodell og signalstrømmer og spenninger angis med små bokstaver

Mellom Base og Emitter "ser" signalet en "dynamisk" motstand r_{π} (BE-dioden). Mellom Emitter og Collector finner vi en strømgenerator som leverer signalstrømmen i_C . Denne strømmen bestemmes av transistorens transkonduktans g_m
 r_{π} og g_m kalles småsignalparametere

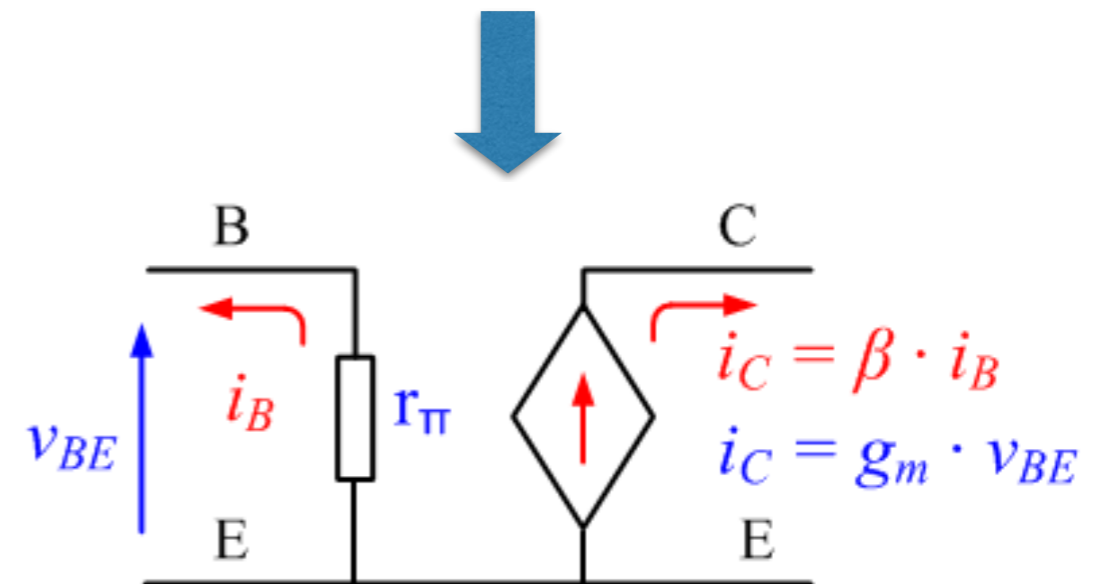
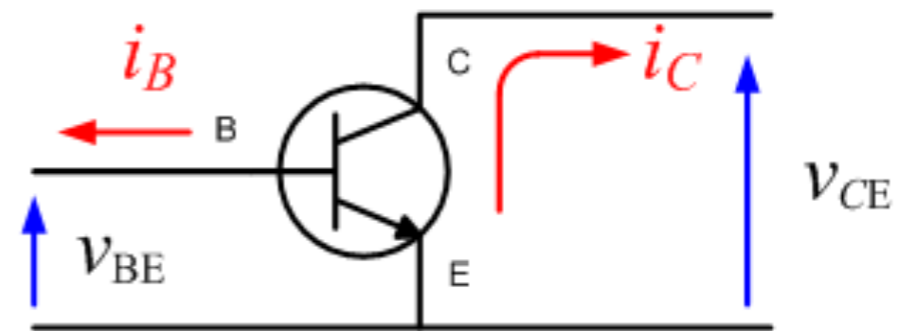

Småsignalparametere

Transkonduktans - steilhet g_m

Emitterstrømmen $I_E = I_{ES} \cdot e^{V_D/V_T}$

hvor $V_D = V_{BE}$ og $V_T = 25mV$

(diodelikningen)

$I_C = I_E - I_B \rightarrow I_C = \alpha \cdot I_E$ $\alpha \cong 1$

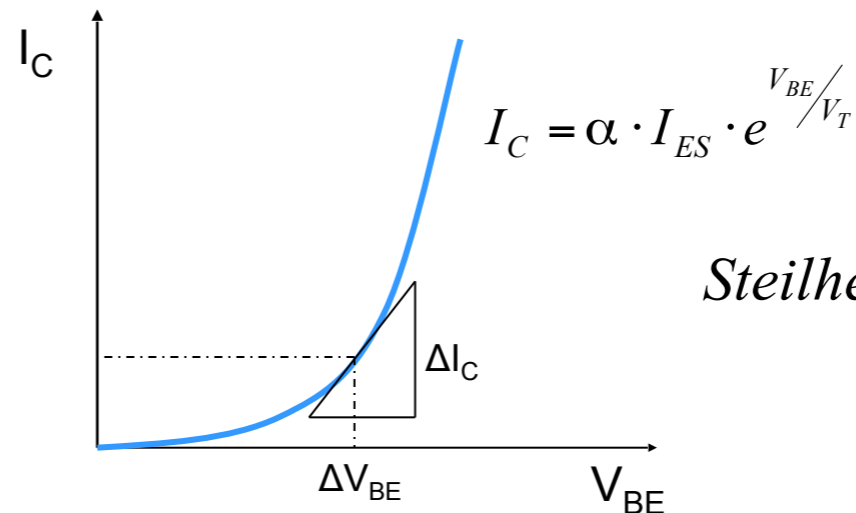

$$\text{Steilhet } g_m = \frac{\Delta I_C}{\Delta V_{BE}}$$

Steilheten g_m er gitt av tangenten til kurven for I_C . Deriverer I_C mhp. V_{EB}

$$g_m = \frac{d(I_C)}{dV_{EB}} = \alpha \cdot I_{ES} \cdot e^{V_{EB}/V_T} \cdot \frac{1}{V_T} = I_C \cdot \frac{1}{V_T} = \frac{I_C}{V_T}$$

$$g_m = \frac{I_C}{V_T}$$

Eksempel : Forsterkeren settes opp med $I_C = 2mA$, som gir:

$$g_m = \frac{I_C}{V_T} = \frac{2mA}{25mV} = 80mS \quad (\text{benevning Siemens})$$

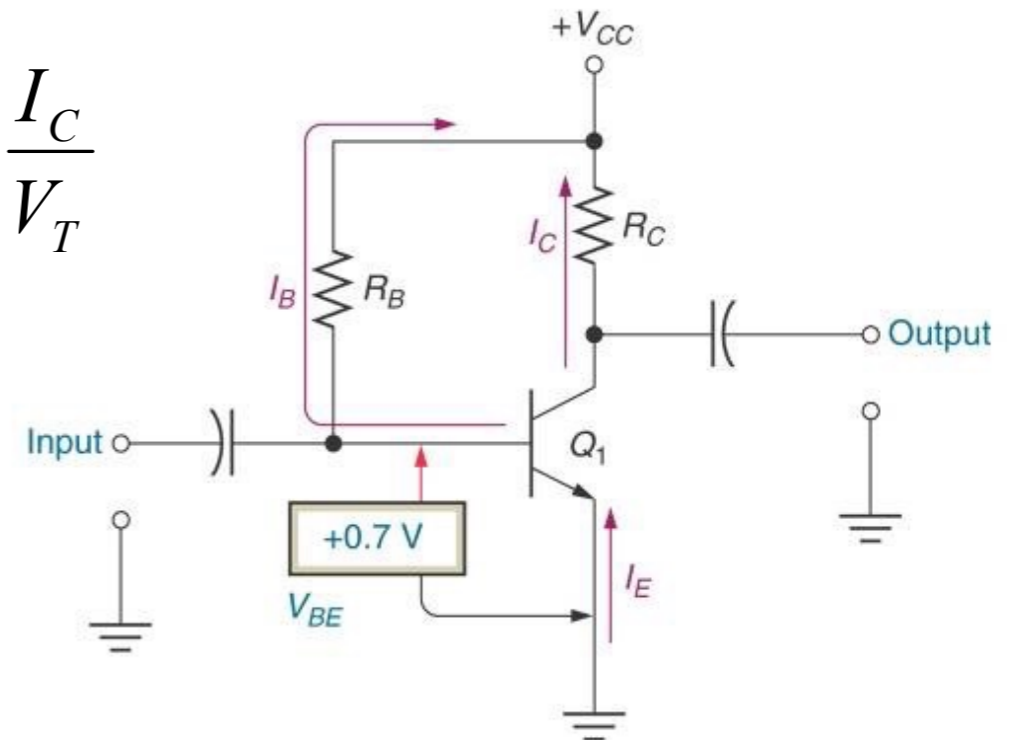

Småsignalparametere

Dynamisk inngangsmotstand r_{π}

$$r_{\pi} = \frac{\Delta V_{EB}}{\Delta I_B}$$

$$I_C = \beta \cdot I_B$$

en liten endring i I_B gir stor endring i I_C

$$1) \Delta I_B = \frac{\Delta I_C}{\beta} \quad 2) g_m = \frac{\Delta I_C}{\Delta V_{EB}} \rightarrow \Delta I_C = g_m \cdot \Delta V_{EB}$$

Forholdet mellom ΔV_{EB} og ΔI_B kalles
den dynamiske inngangsresistansen r_{π}
Kombinerer likning 1) og 2)

$$\Delta I_B = \frac{g_m \cdot \Delta V_{EB}}{\beta}$$

$$r_{\pi} = \frac{\Delta V_{EB}}{\Delta I_B} = \frac{\beta}{g_m} = \frac{\beta \cdot V_T}{I_C}$$

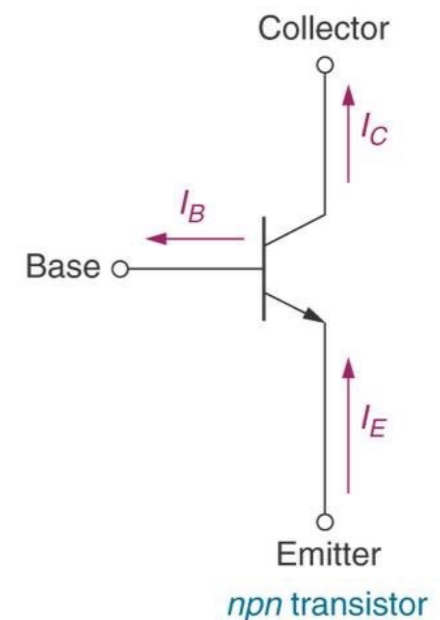
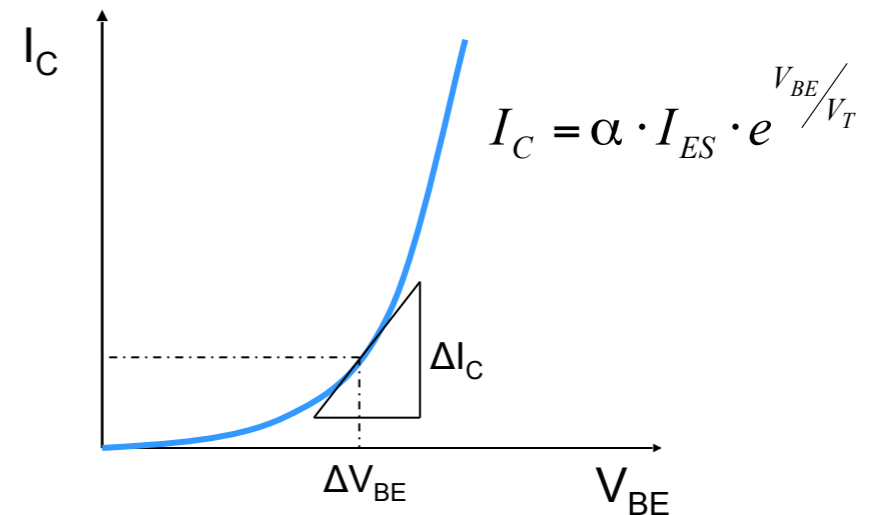

Transistorforsterker

Vi beregner spenningsforsterkningen A_V

$$\text{Steilhet } g_m = \frac{\Delta I_C}{\Delta V_{BE}}$$

$$1) \quad \Delta I_C = g_m \cdot \Delta V_{BE}$$

$$2) \quad \Delta V_{RC} = \Delta I_C \cdot R_C \quad (\text{ohms lov})$$

Setter inn 1) i 2) som gir

$$\Delta V_{RC} = g_m \cdot \Delta V_{BE} \cdot R_C$$

Forsterningen A_V er definert som

$$A_V = \frac{V_{Output}}{V_{Input}} = \frac{\Delta V_{RC}}{\Delta V_{BE}} = g_m \cdot R_C$$

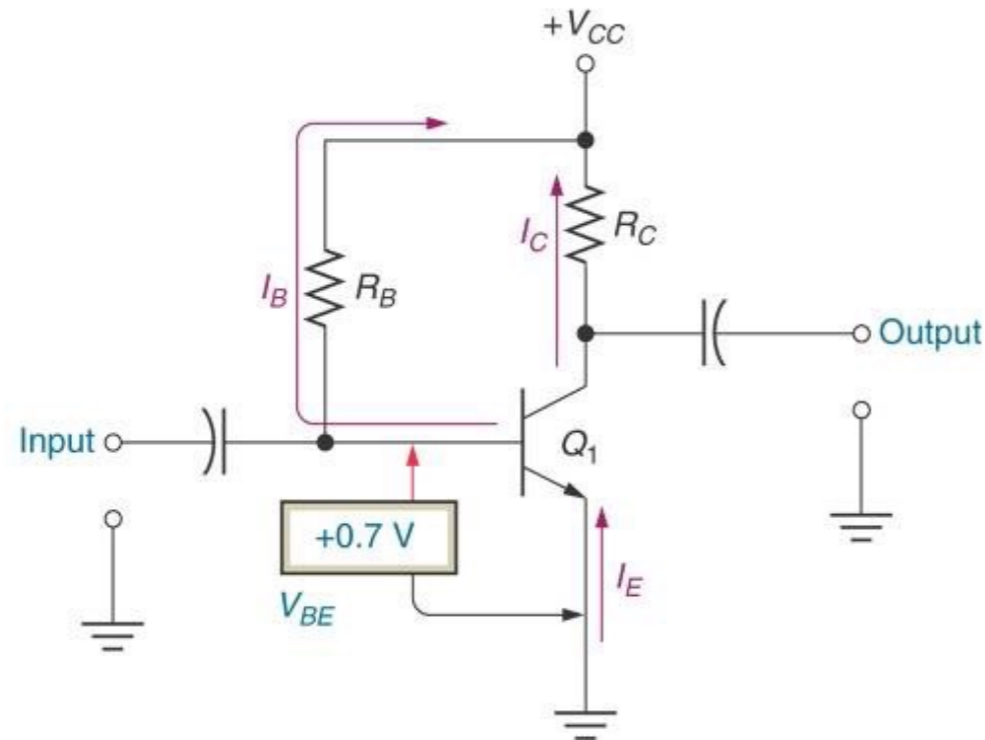

Gitt $V_{CC}=10\text{volt}$ Setter $V_C=5\text{volt}$ Vi bestemmer at $I_C = 2\text{mA}$

$$A_V = g_m \cdot R_C$$

$$\text{Beregner } R_C = \frac{V_{RC}}{I_C} = \frac{5\text{v}}{2\text{mA}} = 2,5 \text{ k}\Omega \quad g_m = \frac{I_C}{V_T} = \frac{2\text{mA}}{25\text{mV}} = 80\text{mS}$$

$$\underline{\underline{\text{Forsterkningen } A_V = 80 \text{ mS} \cdot 2,5 \text{ k}\Omega = 200}}$$

Transistorforsterker

Småsignalmodeller- forsterker med emittermotstand

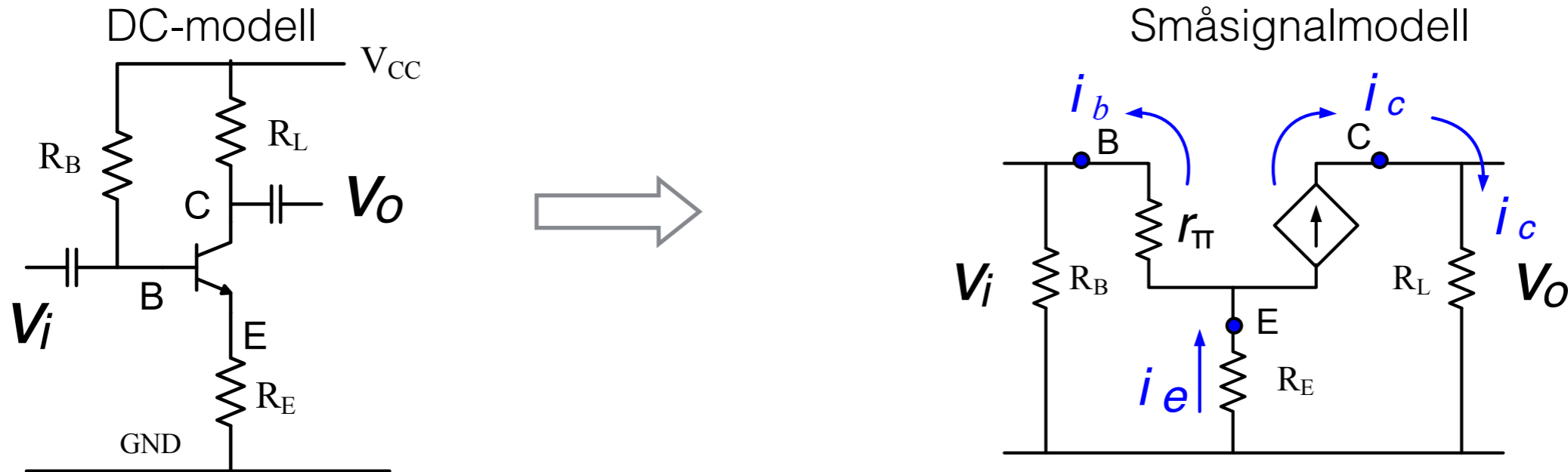

$$v_i = v_{be} + v_E \quad (1) \quad v_{be} = i_b \cdot r_\pi \quad (2)$$

$$v_E = (i_b + i_c) \cdot R_E = (i_b + i_b \cdot \beta) \cdot R_E = i_b (\beta + 1) \cdot R_E \quad (3)$$

Setter (2) og (3) inn i (1)

$$v_i = i_b \cdot r_\pi + i_b (\beta + 1) \cdot R_E \rightarrow i_b = \frac{v_i}{r_\pi + (\beta + 1) \cdot R_E} \quad (4)$$

$$v_o = -i_c \cdot R_L = -i_b \cdot \beta \cdot R_L \rightarrow (4) \rightarrow = -\frac{\beta \cdot v_i}{r_\pi + (\beta + 1) \cdot R_E} \cdot R_L \quad A_v = -\frac{v_o}{v_i}$$

Bemerk (-) Forsterkeren inverterer signalet.

Positivt signal-sving på basen kommer ut som negativt sving på kollektor

Transistorforsterker

Småsignalmodeller- forsterker med emittermotstand

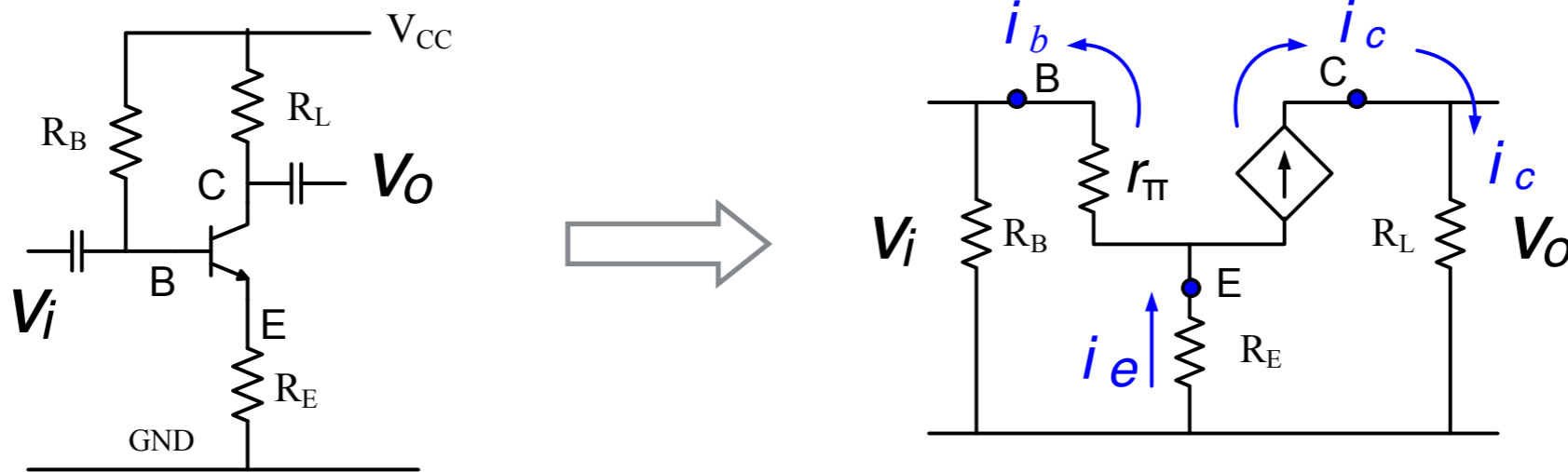

$$v_i = i_b \cdot r_\pi + i_b(\beta + 1) \cdot R_E \rightarrow i_b = \frac{v_i}{r_\pi + (\beta + 1) \cdot R_E} \quad (4)$$

$$v_o = -i_c \cdot R_L = -i_b \cdot \beta \cdot R_L \rightarrow (4) \rightarrow = -\frac{\beta \cdot v_i}{r_\pi + (\beta + 1) \cdot R_E} \cdot R_L$$

$$A_v = \frac{v_o}{v_i} = -\frac{\beta \cdot R_L}{r_\pi + (\beta + 1) \cdot R_E} \quad \text{setter inn } r_\pi = \frac{\beta}{g_m}$$

$$A_v = -\frac{g_m \cdot R_L}{1 + (1 + \frac{1}{\beta}) \cdot g_m \cdot R_E} \approx -\frac{g_m \cdot R_L}{1 + g_m \cdot R_E} \approx -\frac{R_L}{R_E} \Rightarrow \boxed{A_v \approx -\frac{R_L}{R_E}}$$

Ser på "input resistance" til transistoren $r_{inn} = \frac{v_i}{i_b} \rightarrow \text{fra (4)} \rightarrow \underline{\underline{r_\pi + (\beta + 1)R_E}}$

Transistorforsterker

Småsignalmodeller- forsterker med emittermotstand Forsterkning

Forsterker med emittermotstand

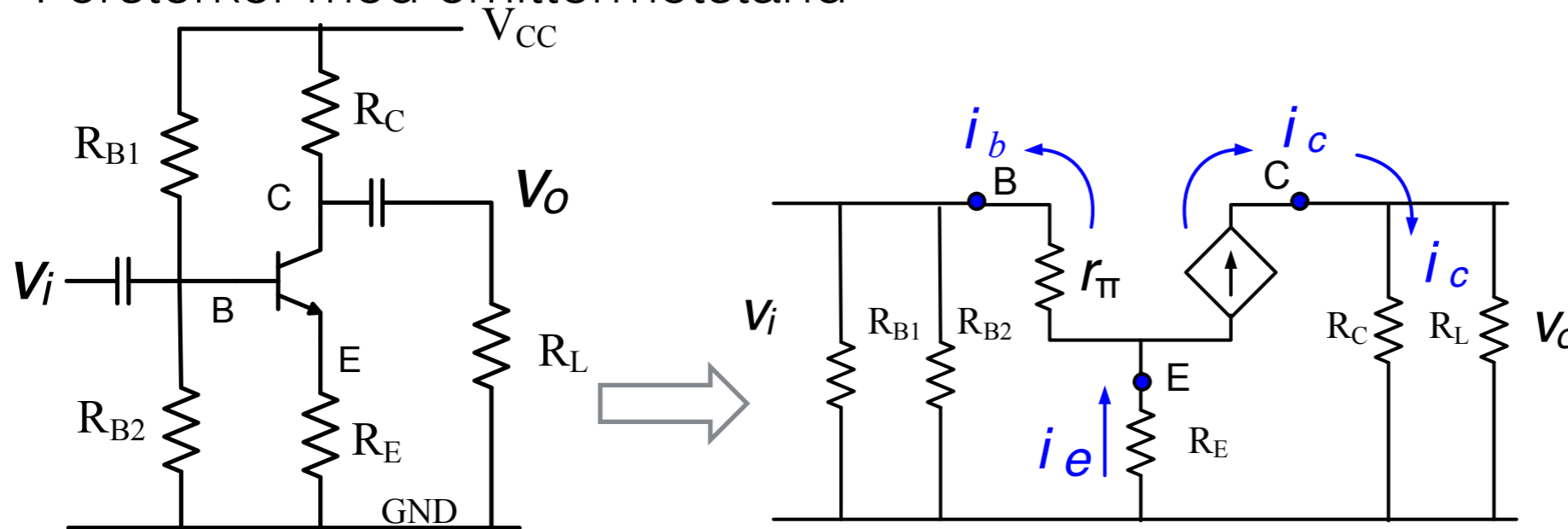

$$A_v \approx -\frac{R_C \parallel R_L}{R_E}$$

Signalkilden ser inn mot en motstand

$R = R_{B1} \parallel R_{B2} \parallel r_{inn}$ hvor

$$r_{inn} = r_{\pi} + (\beta + 1)R_E$$

Forsterker med avkoplet emittermotstand

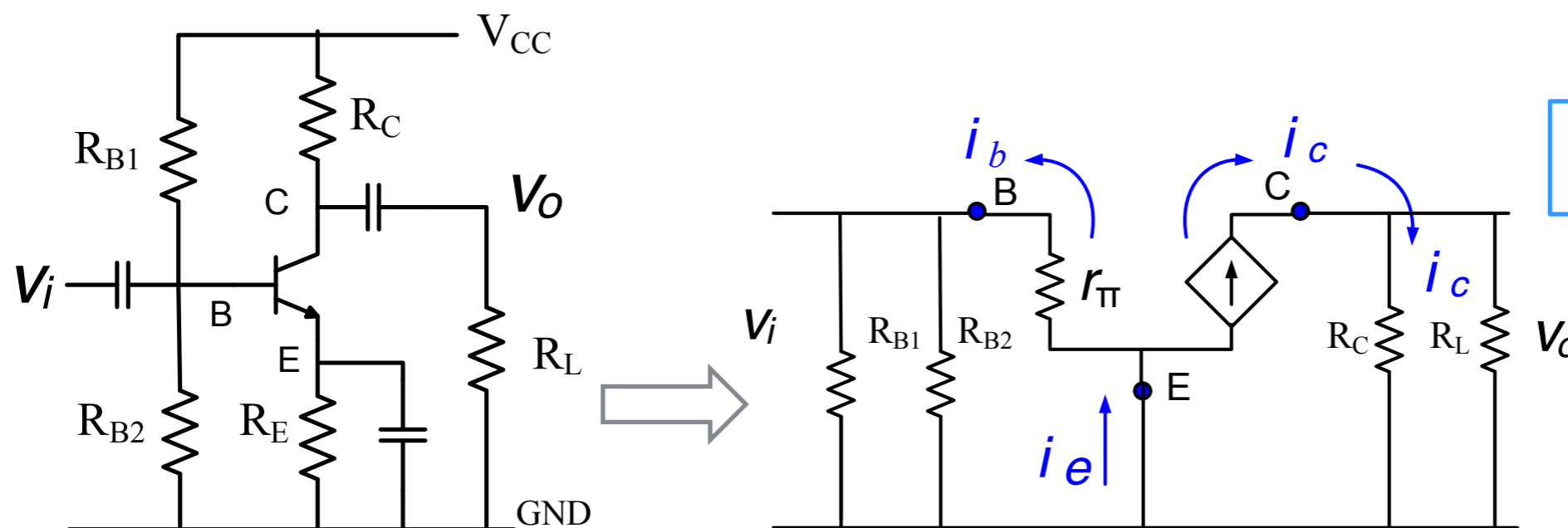

Forsterkning

$$A_V = -g_m \cdot (R_C \parallel R_L)$$

$$g_m = \frac{I_C}{V_T}$$

Transistorforsterker

Regneeksempel

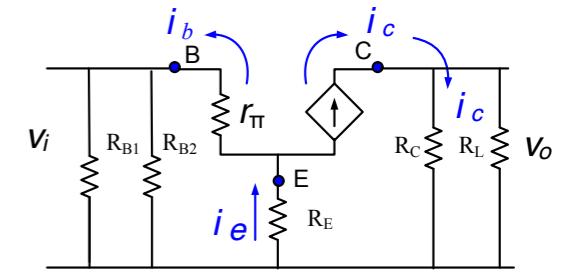
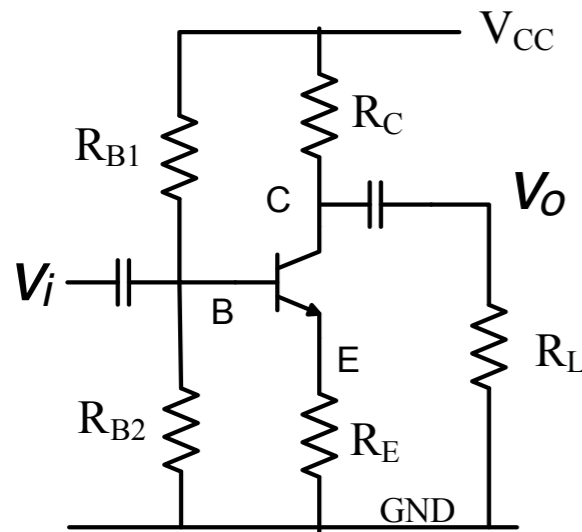

$$R_{B1} = 35 \text{ k}\Omega, R_{B2} = 15 \text{ k}\Omega, R_C = 6 \text{ k}\Omega,$$

$$R_L = 1,5 \text{ k}\Omega, R_E = 1 \text{ k}\Omega, I_C = 2 \text{ mA}, \beta = 200$$

$$g_m = \frac{I_C}{V_T} = \frac{2 \text{ mA}}{25 \text{ mV}} = 80 \text{ mS} \quad r_{\pi} = \frac{\beta}{g_m} = \frac{200}{80 \text{ mS}} = 2,5 \text{ k}\Omega$$

$$R_P = R_C \parallel R_L = \frac{6 \text{ k} \cdot 1,5 \text{ k}}{6 \text{ k} + 1,5 \text{ k}} = 1,2 \text{ k} \quad A_V = -\frac{R_P}{R_E} = \frac{1,2 \text{ k}}{1 \text{ k}} = -1,2$$

Hvis vi avkoplemittermotstanden med en kondensator

$$A_V = -g_m \cdot R_P = 80 \text{ mS} \cdot 1,2 \text{ k} = -96$$

$$R_{inn} = r_{\pi} + (\beta + 1)R_E = 2,5 \text{ k} + 201 \cdot 1 \text{ k} = 203,5 \text{ k}\Omega$$

Lastlinjen endres i forhold til DC-modellen

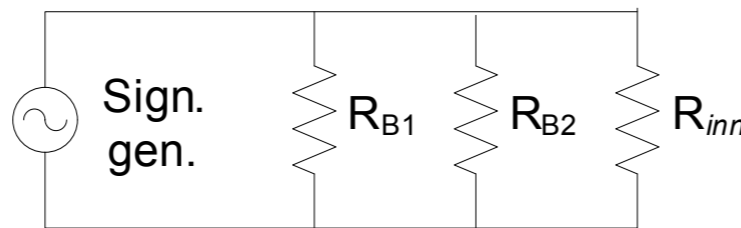
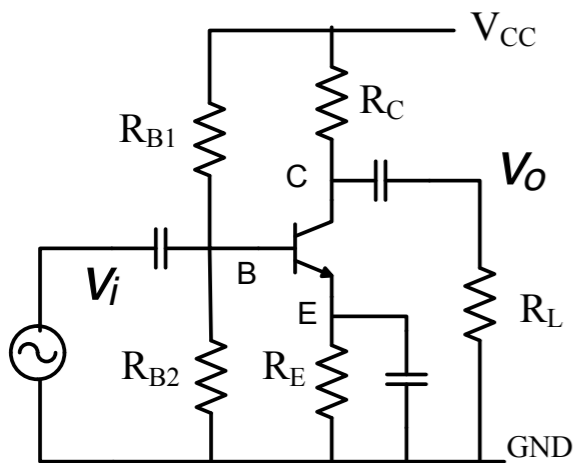

generatoren ser inn mot $R_{INN} = R_{B1} \parallel R_{B2} \parallel R_{inn} \cong 10 \text{ k}\Omega$

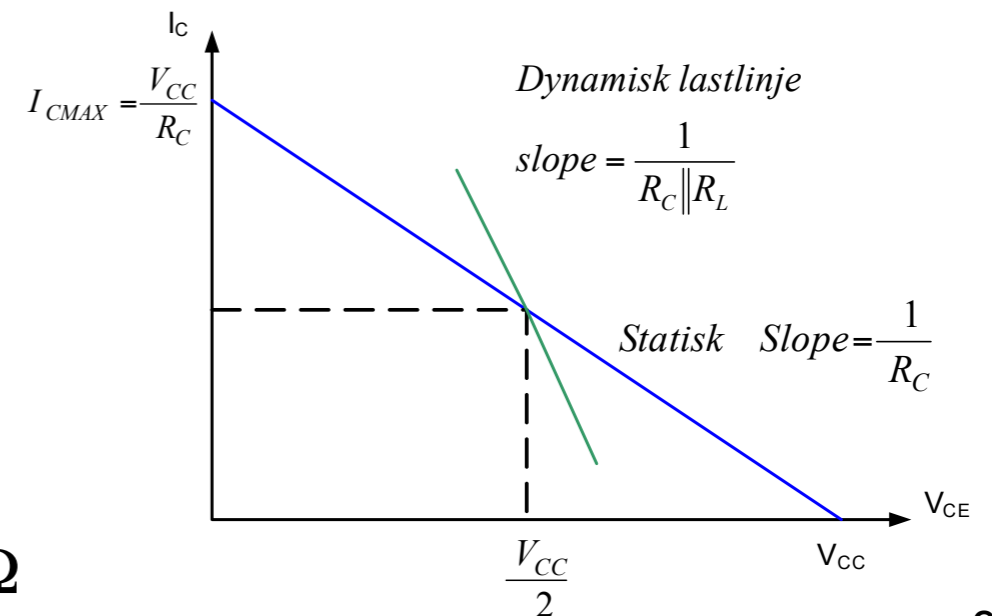

Transistorforsterker

EMITTERFØLGER - Signalet hentes ut over emittermotstanden

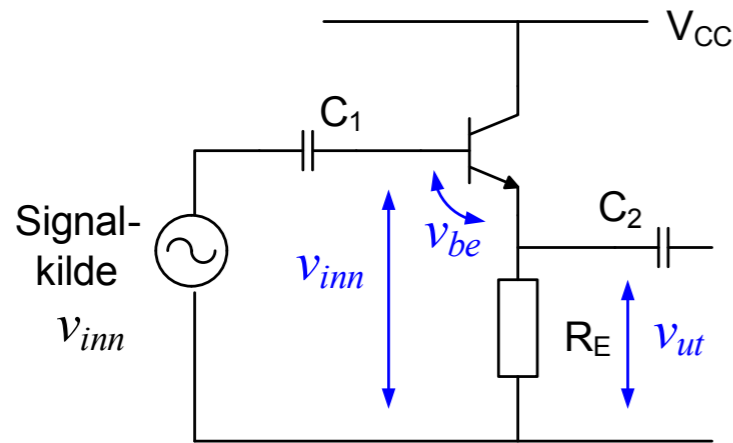

Forenklet skjema – utelatt spenningsdeler på basen

Småsignalmodellen

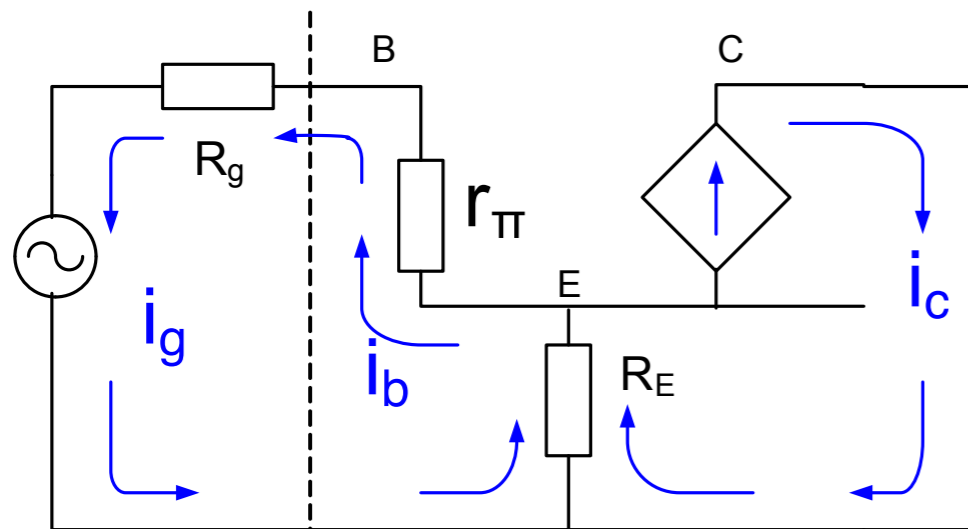

$$i_b = \frac{v_{inn}}{r_{\pi} + (\beta + 1) \cdot R_E}$$

$$A_v = \frac{v_{ut}}{v_{inn}} = \frac{(\beta + 1) \cdot R_E}{r_{\pi} + (\beta + 1) \cdot R_E} \cong 1$$

Betrakt signalspenningene $v_{inn} = v_{be} + v_{ut}$

v_{be} er liten $\rightarrow v_{inn} \approx v_{ut}$

Ser på tilkoplingen av en signalgenerator med indre motstand R_g og signal v_{inn}

Vi ser bort fra kondensatorene – de stopper DC men slipper signalet uhindret igjennom

$$i_e = (\beta + 1) \cdot i_b \rightarrow i_g = i_b \rightarrow i_e = (\beta + 1) \cdot i_g$$

Strømførsterkning

$$A_i = \frac{i_e}{i_g} = (\beta + 1) \quad \text{Effektforsterkning} \quad P = v \cdot i$$

$$v_{ut} + v_{be} = v_{inn} \rightarrow (\beta + 1) \cdot i_b \cdot R_E + i_b \cdot r_{\pi} = v_{inn}$$

$$v_{ut} = i_e \cdot R_E = (\beta + 1) \cdot i_b \cdot R_E = \frac{(\beta + 1) \cdot R_E \cdot v_{inn}}{r_{\pi} + (\beta + 1) \cdot R_E}$$

Stor strømførsterkning
- Ingen spenningsforsterkning