

Grounding (Ott3)

Two kinds of grounding:

- Power ground (heavy current/security ground)
- Signal ground

Ground for high power:

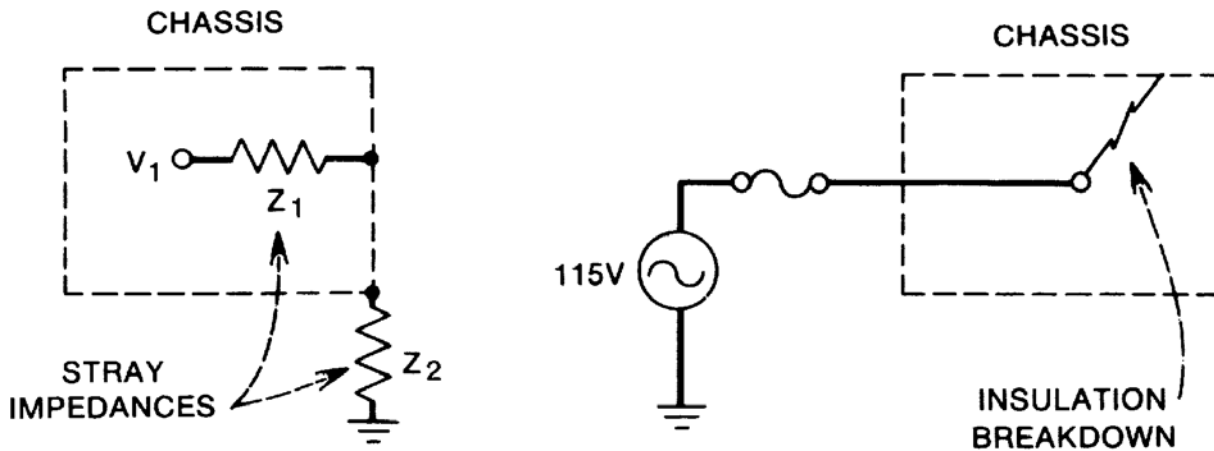

Figure 3-1. Chassis should be grounded for safety. Otherwise, it may reach a dangerous voltage level through stray impedances (left) or insulation breakdown (right).

Assume the chassis is not grounded ($Z_2 \gg 0\Omega$):

V_1 is an internal point at a high voltage connected to the high voltage mains. The voltage potential on the chassis can be expressed as:

$$V_{chassis} = \left(\frac{Z_2}{Z_1 + Z_2} \right) V_1$$

Typically Z_1 and Z_2 are both large while the ratio between them may be arbitrary. That means that the voltage on the chassis may be close to V_1 . If an electrically grounded person is touching the chassis he/she may experience an unpleasant electrical shock even though the current is small (small current due to large Z_1).

The right side of figure 3-1 shows a more dangerous situation. The figure illustrates an example where the isolation is broken so that Z_I is close to 0Ω . Hence the chassis may have a voltage of V_I . The chassis may deliver a maximum current decided by the fuse. If an electrically grounded person touches the chassis the entire current may pass through his/her body with fatal consequences.

If, on the other hand the chassis was grounded

- The current would pass through the ground cable instead of the person.
- The cable would be low ohmic resulting in a high current making the fuse go within short time with the result that the chassis lose the voltage.

Mains power systems:

- Norwegian (220V)
- American (115V)

The Norwegian system:

The traditional Norwegian system has three phases with 120 degrees between the phases. Ground is in the middle and not used for anything else than security. Loads are connected between pairs of the phases (3 combinations). 220Vrms between two phases (Approx. 110Vrms between all phases and ground.)

Colours: Yellow or Yellow/Green for ground. Black, white and blue for the three phases. Brown and sometimes blue after a switch. Red is not common and should not be used.

American system:

Ground used both for security ground and as fixed current return but in two different cables. Supply phase 120V from ground.

American system.

115V system:

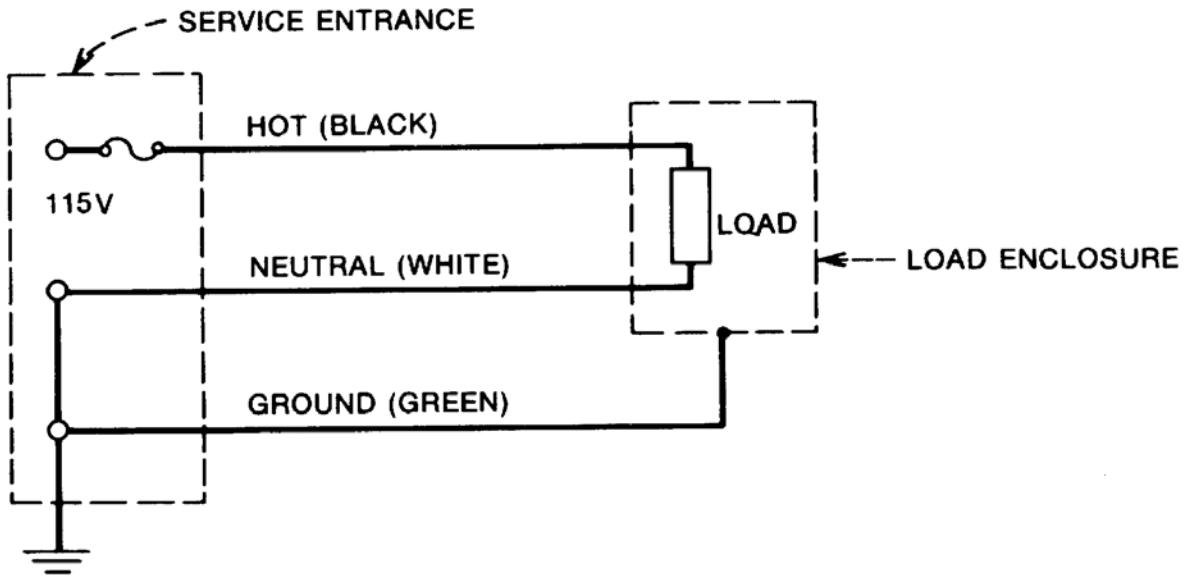

Figure 3-2. *Standard 115-V ac power distribution circuit has three leads.*

Fuse only on the 115V phase. Ground for return current and security ground connected in local trafo station.

230V system:

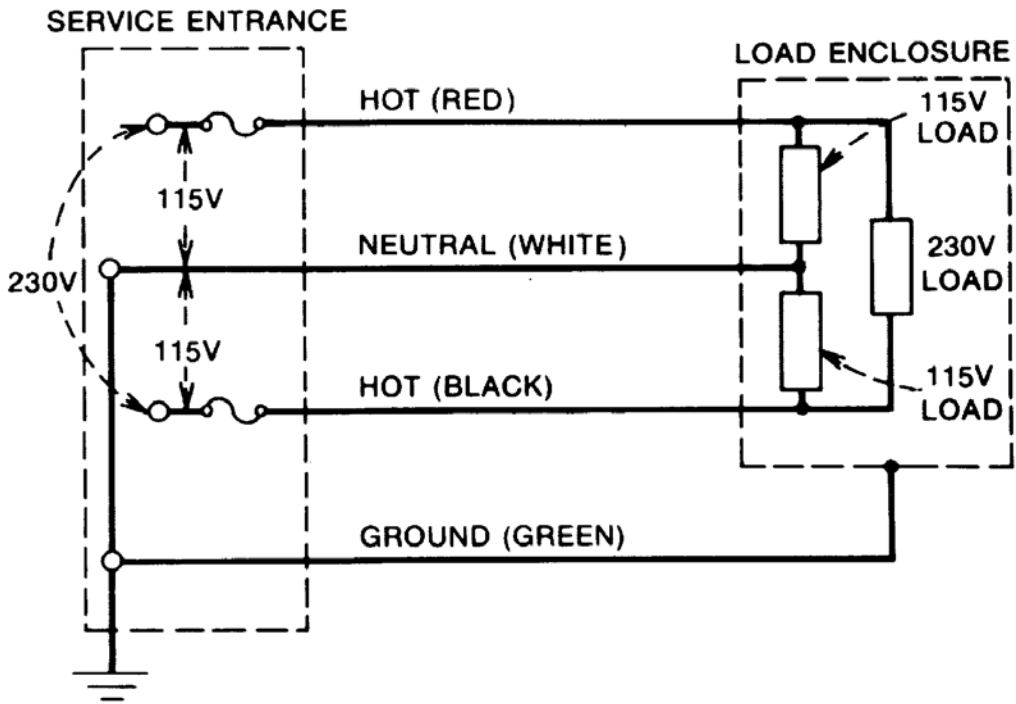

Figure 3-3. *Combination 115/230-V ac power distribution circuit has four leads.*

Signal ground

(A low impedance path for return current.)

Three alternative architectures:

1. One point ground
2. Multi point ground
3. Hybrid ground

1. One point ground

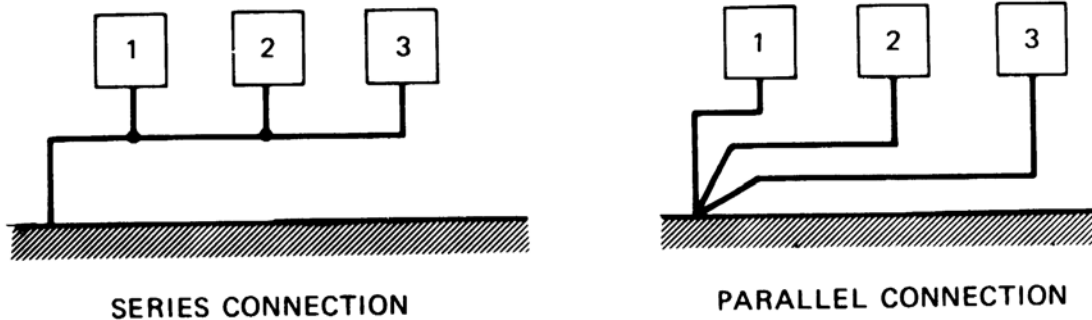

Figure 3-4. Two types of single-point grounding connections.

The serial routing is the most common but also the most noisy.

2. Multi point ground

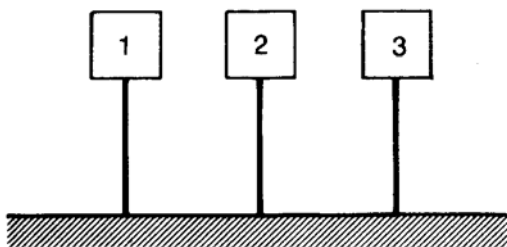

Figure 3-5. Multipoint grounding connections.

1. One point ground:

Serial:

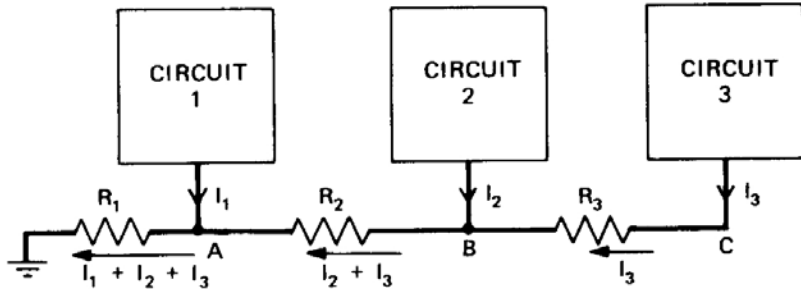

Figure 3-6. Common ground system is a series ground connection and is undesirable from a noise standpoint but has the advantage of simple wiring.

$$V_A = (I_1 + I_2 + I_3)R_1$$

$$V_C = (I_1 + I_2 + I_3)R_1 + (I_2 + I_3)R_2 + I_3R_3$$

Single line with significant common noise.

Parallel:

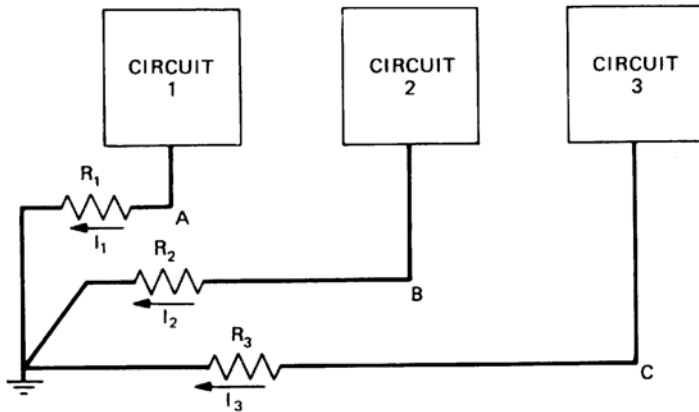

Figure 3-7. Separate ground system is a parallel ground connection and provides good low-frequency grounding but is mechanically cumbersome.

$$V_A = I_1R_1$$

$$V_C = I_3R_3$$

Less noise but more wiring.

Not suitable for longer lines and higher frequencies. $L \ll \lambda/20$.

2. Multi point ground

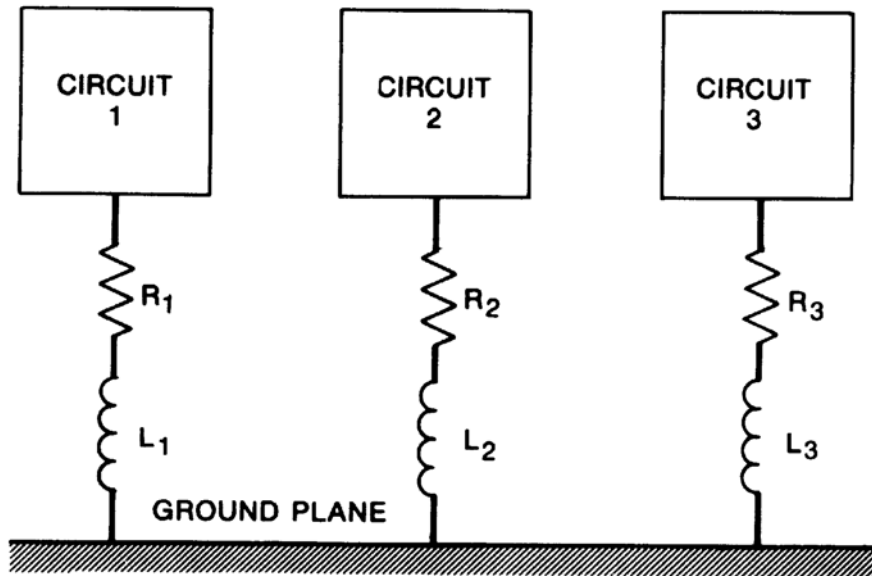

Figure 3-8. *Multipoint ground system is a good choice at frequencies above 10 MHz. Impedances R_1 – R_3 and L_1 – L_3 should be minimized.*

Used for higher frequencies ($>10\text{MHz}$) and in digital designs when it is important to reduce the inductance because ωL may be significant. At lower frequencies when the resistance (say in the ground plane) is more essential than the inductance, this solution should not be used. Instead a one point parallel solution should be selected.

3. Hybrid ground

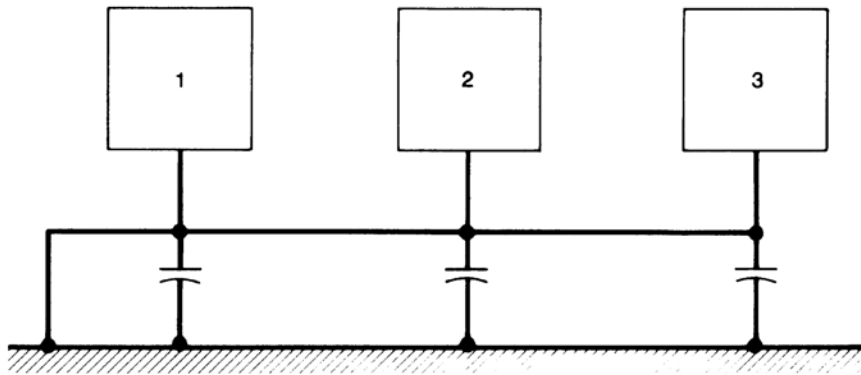

Figure 3-9. A hybrid ground connection that acts as a single-point ground at low frequencies and a multipoint ground at high frequencies.

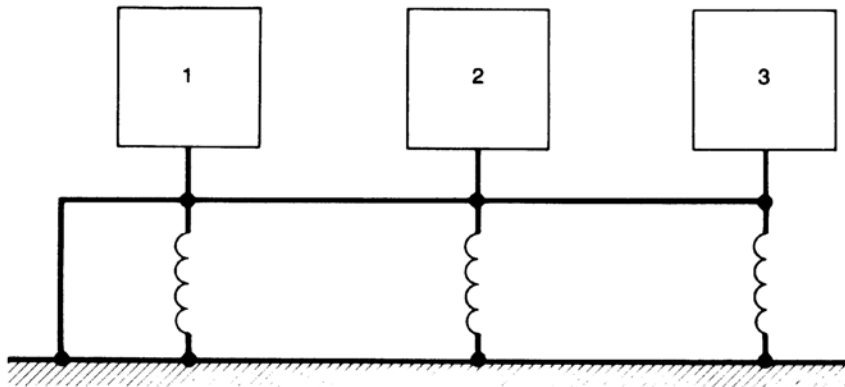

Figure 3-10. A hybrid ground connection that acts as a multipoint ground at low frequencies and a single-point ground at high frequencies.

Fig. 3.9: Behave as a one point ground at lower frequencies and a multipoint ground at higher frequencies. Used to ground cables and/or shields.

Fig. 3.10: Multi point grounding at lower frequencies and one point grounding at higher frequencies. Used, say, when a low frequency coupling to the security ground for the mains is needed for each module at the

same time as we want a single point grounding at the higher frequencies.

Example 1:

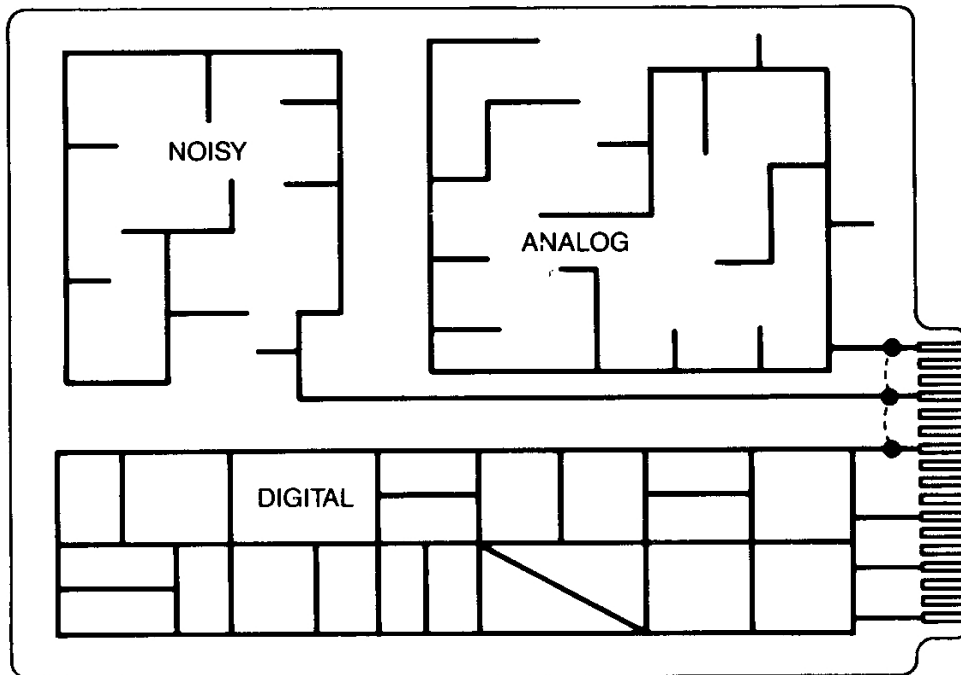

Figure 3-11. A printed wiring board with three separate ground systems, one for the digital logic, one for the low-level analog circuits, and one for the “noisy” circuits.

Here we have separated routing to avoid common impedance. Multi point grounding for the digital part, one point serially for the “noisy” part and one point parallel for the “analogue” part.

The chosen layout is a compromise between

- Low noise and a lot of space and
- More noise and less space required.

An example of a common grounding strategy is on line for each of three classes:

- Noise sensitive modules
- Noise generating modules
- Cabinet, chassis

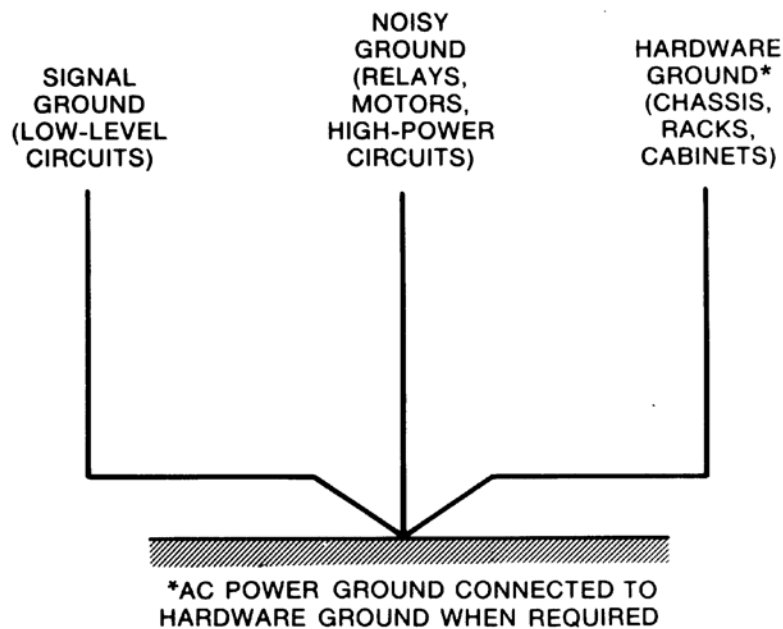

Figure 3-12. *These three classes of grounding connections should be kept separate to avoid noise coupling.*

Example 2:

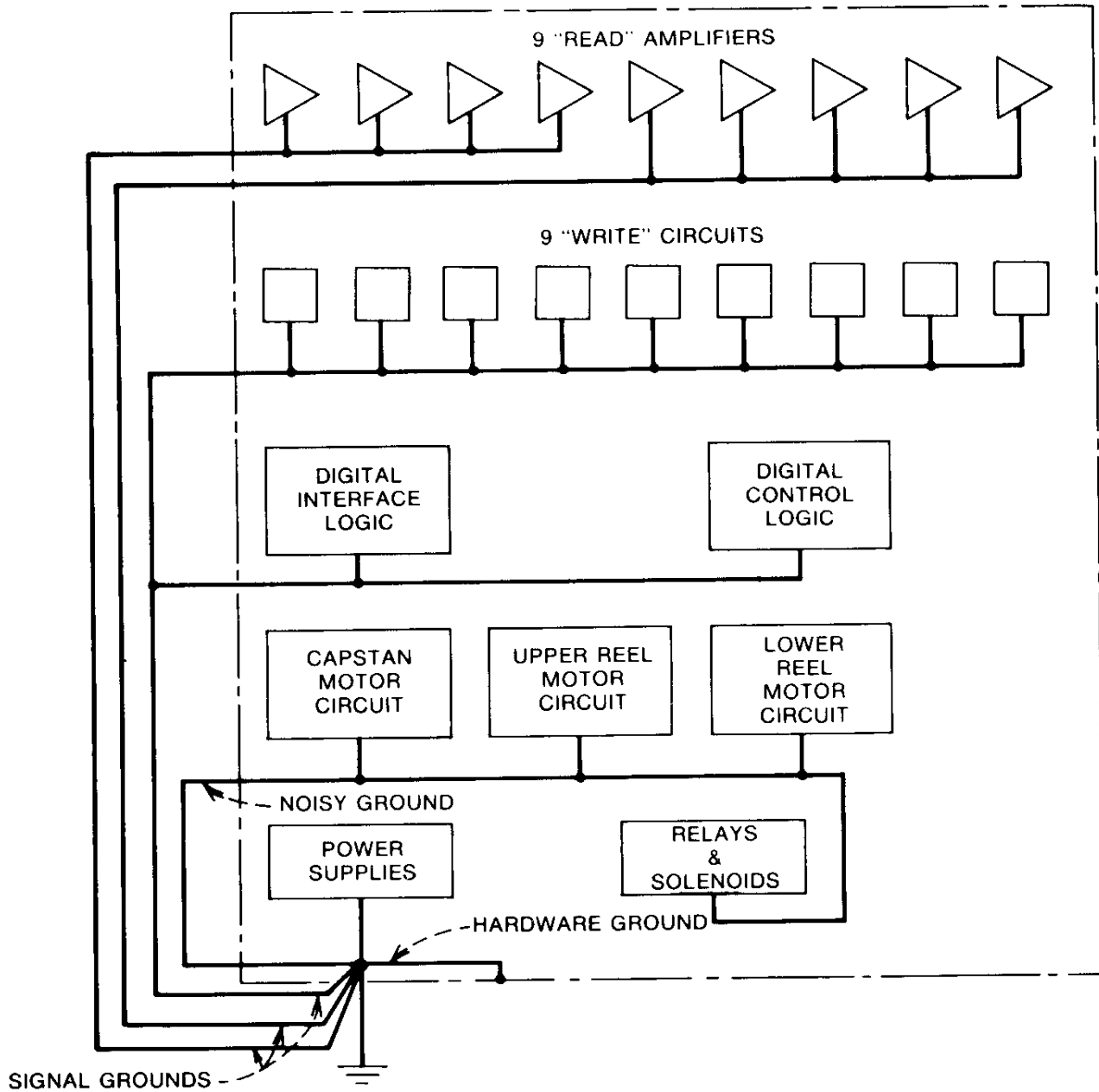

Figure 3-13. Typical grounding system for nine-track digital tape recorder.

The common connection point for the ground lines should be as close as possible to the power supply.

Example 3:

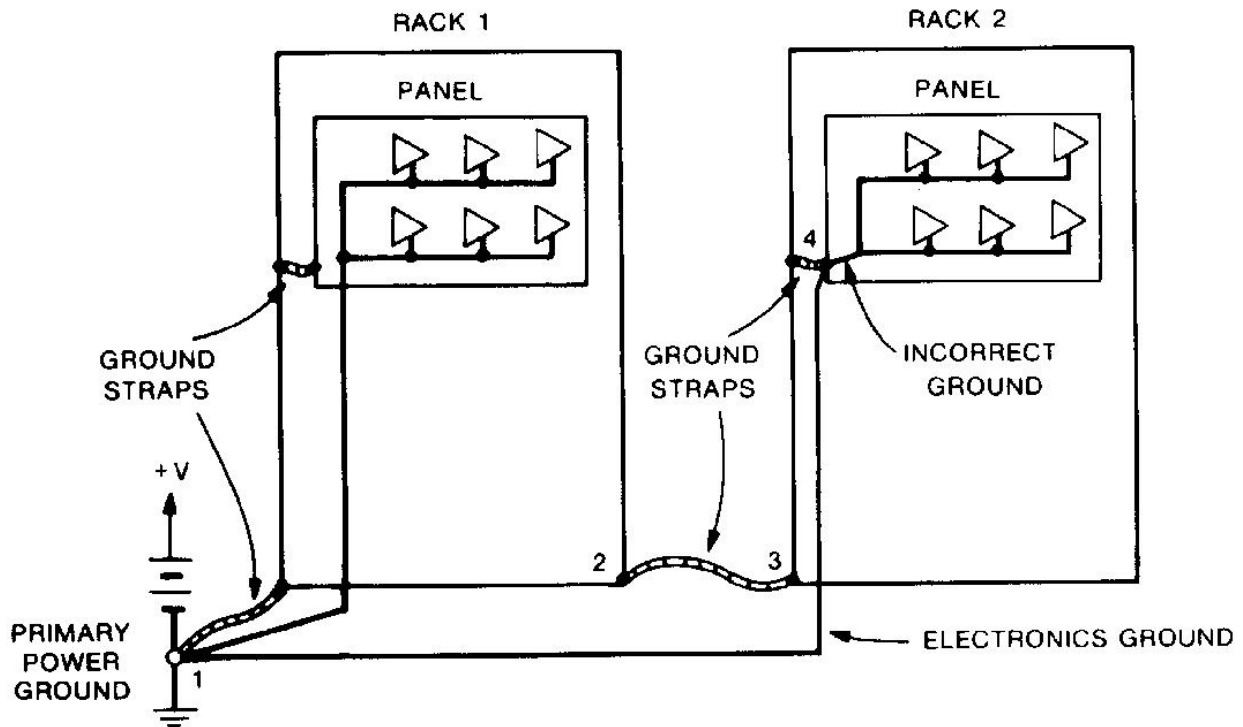

Figure 3-14. Electronic circuits mounted in equipment racks should have separate ground connections. Rack 1 shows correct grounding; rack 2 shows incorrect grounding.

One contra two points grounding of a sensor- amplifier system.

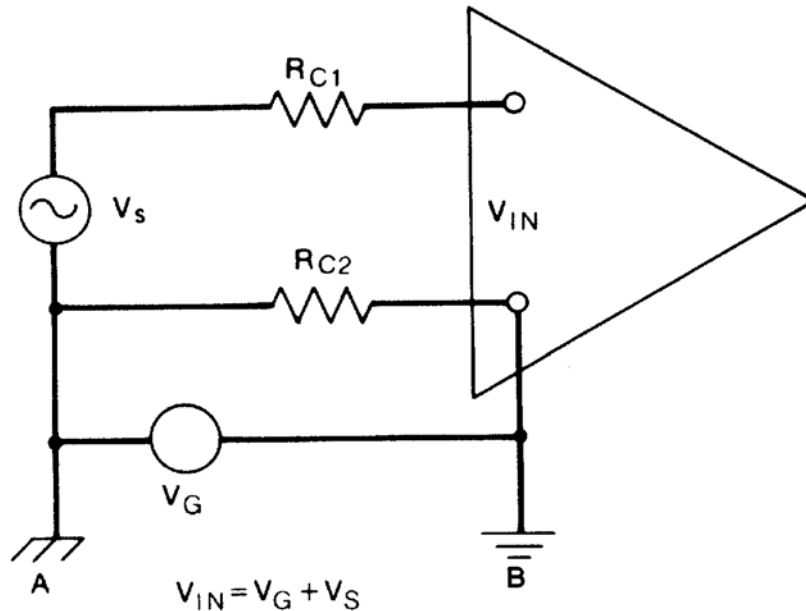

Figure 3-15. Noise voltage V_G will couple into the amplifier if the circuit is grounded at more than one point.

V_s is the wanted source signal..

V_G is the unwanted voltage difference between the two ground points. A and B are both ground points that are connected together and that ideally should have the same potential. However, for different possible reasons, there is a minor difference in potential between these two ground points. This is illustrated by using different ground symbols for the two points.

Alternative 1: Two ground connections

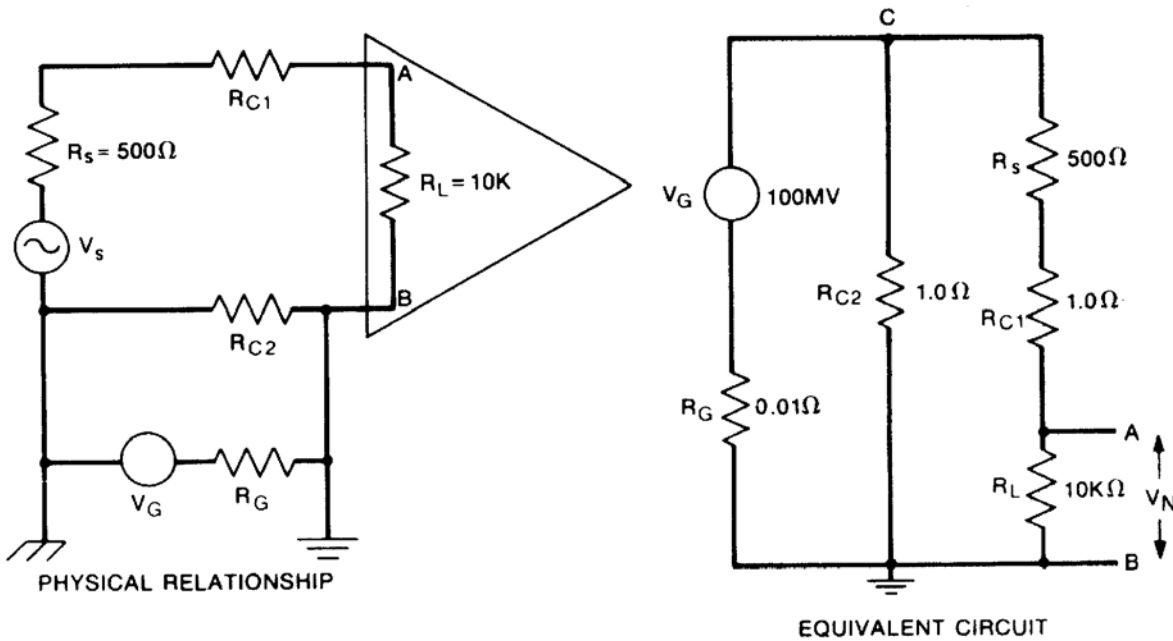

Figure 3-16. With two ground connections, much of the ground-potential difference appears across the load as noise.

When

$$R_{C2} \ll R_S + R_{C1} + R_L$$

we have that

$$V_N = \left[\frac{R_L}{R_L + R_{C1} + R_S} \right] \left[\frac{R_{C2}}{R_{C2} + R_G} \right] V_G$$

Example:

V_G may be due to magnetic coupling or due to passing currents running in ground.

$$V_G = 10A \cdot 0.01\Omega = 100mV$$

$$R_S = 500\Omega,$$

$$R_{C1} = R_{C2} = 1\Omega,$$

$$R_L = 10k\Omega,$$

$$\Rightarrow V_N = 95mV.$$

Alternative 2: One ground connection.

Signal source is not grounded (almost):

Z_{SG} is a parasitic large impedance. .

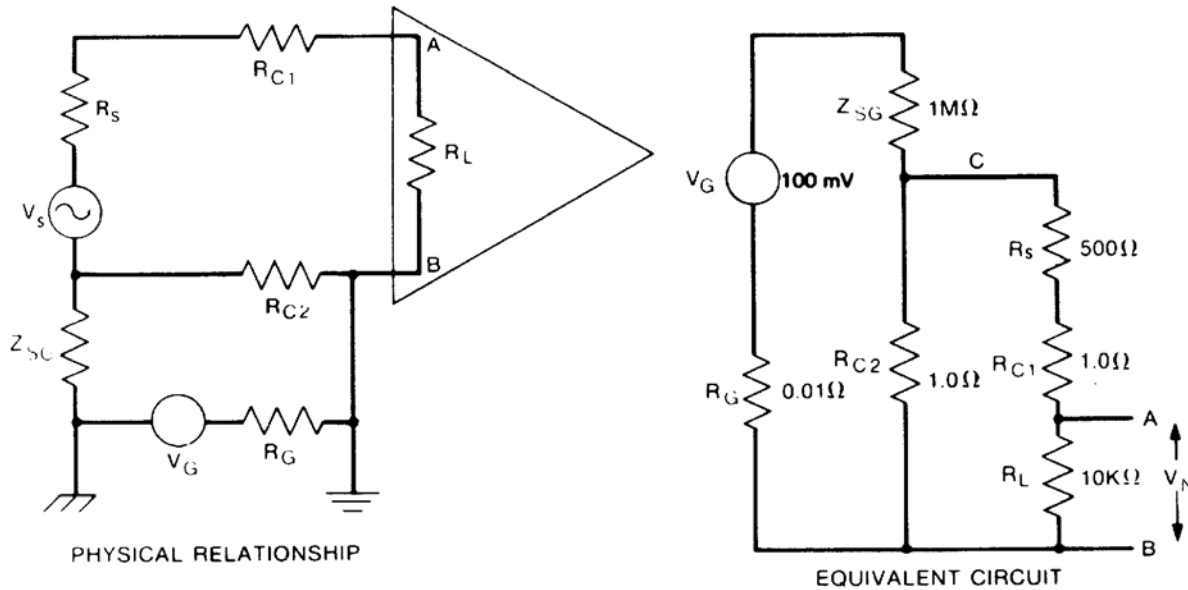

Figure 3-17. A large impedance between the source and ground keeps most of the ground-potential difference away from the load and reduces noise.

When

$$R_{C2} \ll R_S + R_{C1} + R_L \text{ and } Z_{SG} \gg R_{C2} + R_G$$

we have that

$$V_N = \left[\frac{R_L}{R_L + R_{C1} + R_S} \right] \left[\frac{R_{C2}}{Z_{SG}} \right] V_G$$

Example:

Same values as in the previous example plus:

$$Z_{SG} = 1 \text{ M}\Omega$$

$$\Rightarrow V_N = 0.095 \mu\text{V}$$

Shielded, packaged amplifiers

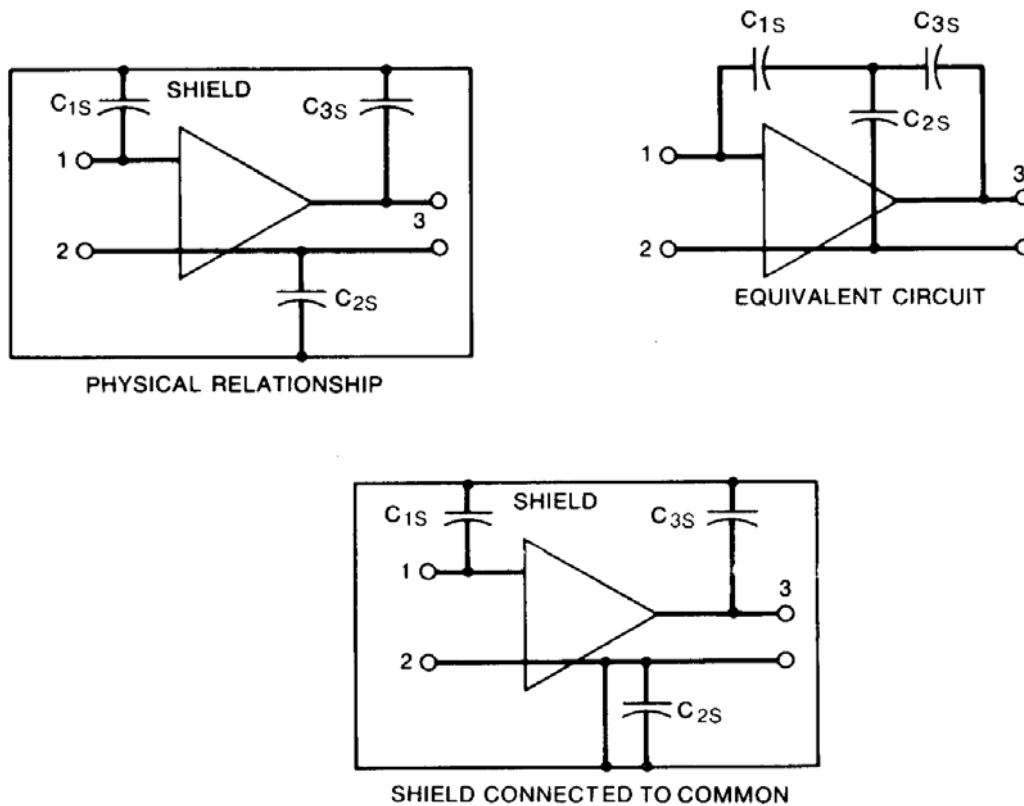

Figure 3-18. Amplifier shield should be connected to the amplifier common.

If the house is not properly grounded it may be a part of a unwanted feedback and result in instability. Proper grounding is illustrated at the bottom figure. Here the package house is coupled to the common input/output reference ground.

How to ground the shield?

Case 1: When the AMP is directly or indirectly grounded.

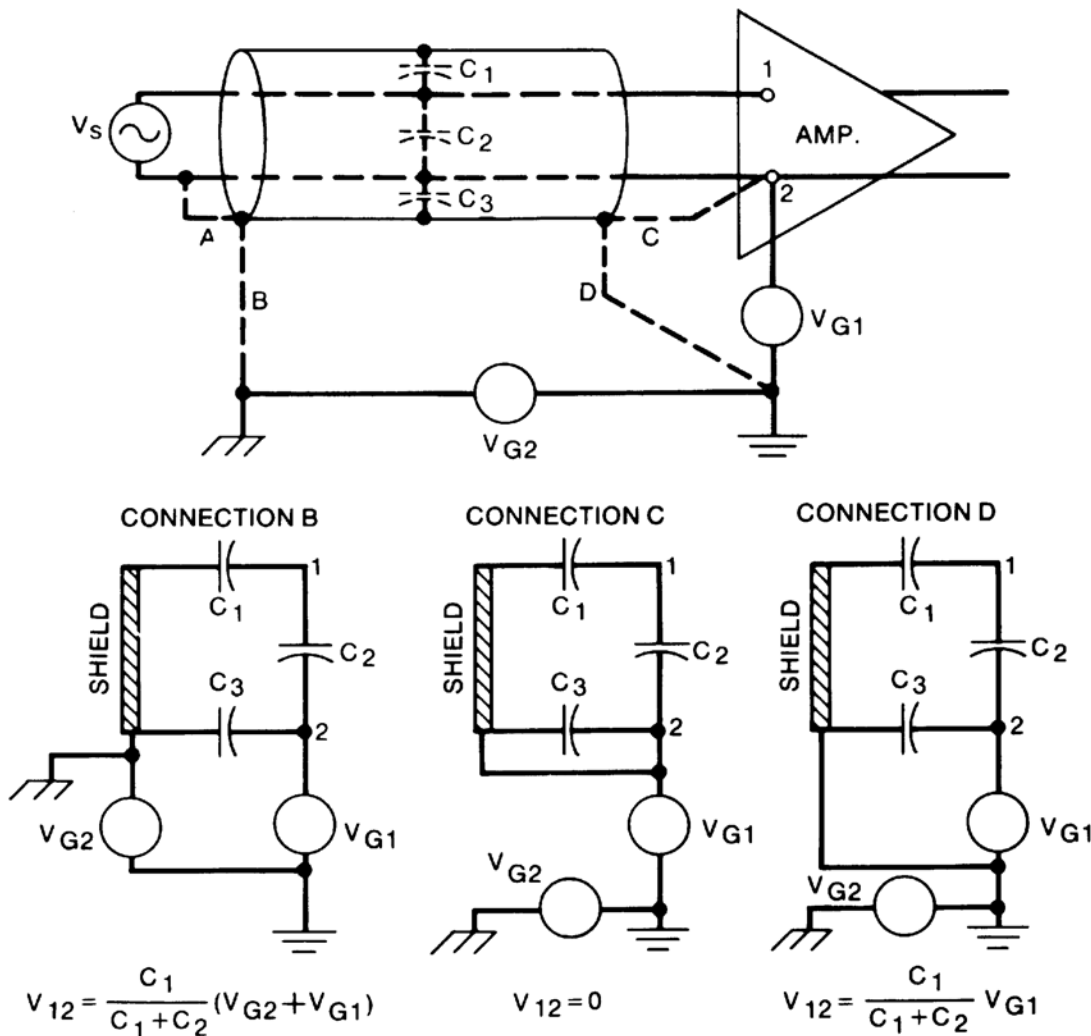

Figure 3-19. When amplifier is grounded, the best shield connection is C, with shield connected to amplifier common.

A: Shield noise will return through one of the signal wires. This is the worst case.

Prioritised order: C, D, B, and A.

Case 2: When the signal source is directly or indirectly grounded.

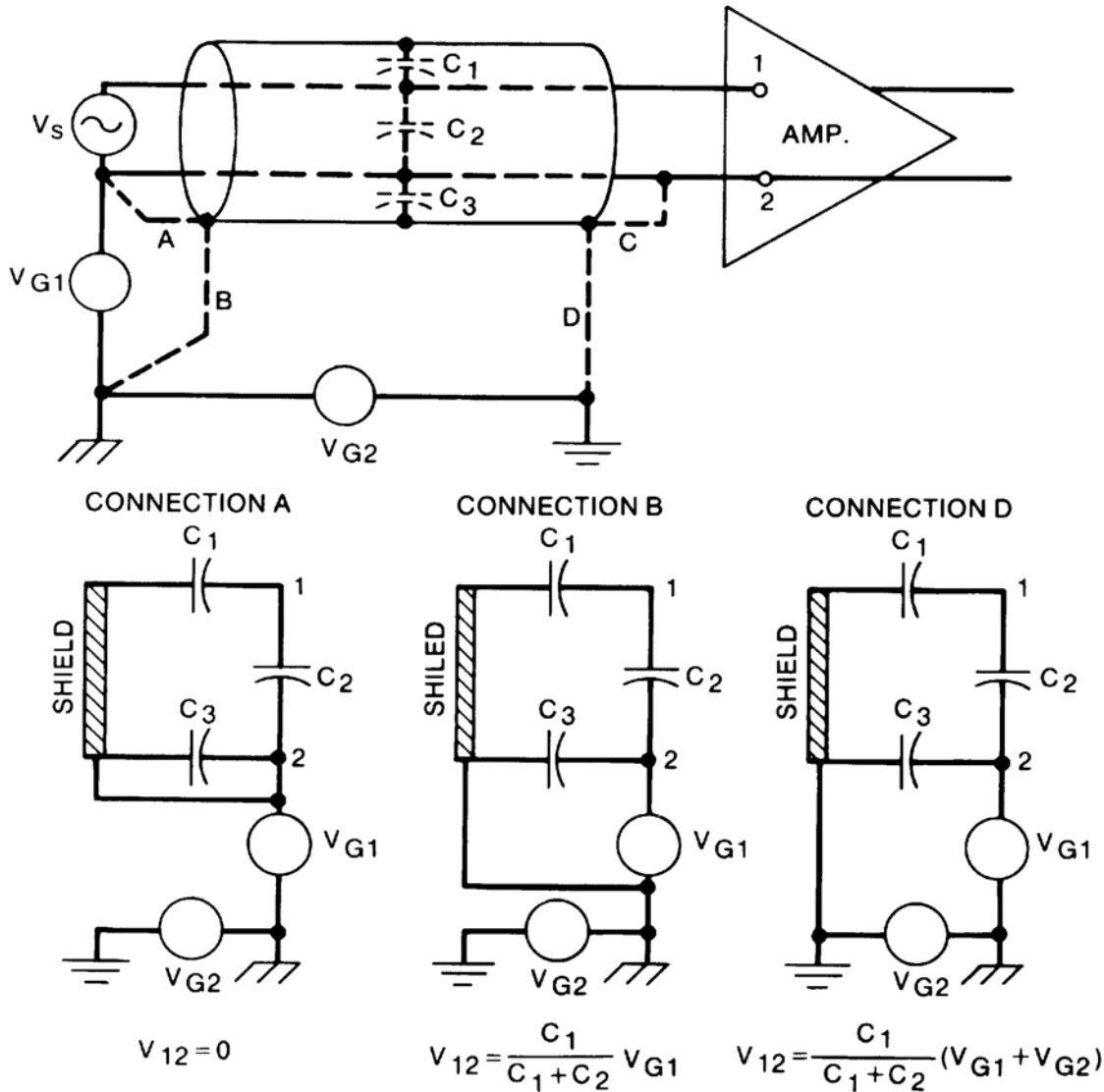

Figure 3-20. When source is grounded, the best shield connection is A, with shield connected to the source common. The configuration can also be used with a differential amplifier.

C: Shield noise will return through one of the signal wires. This is the worst case in this setup.

Prioritised order: A, B, D and C.

Examples of shield grounding

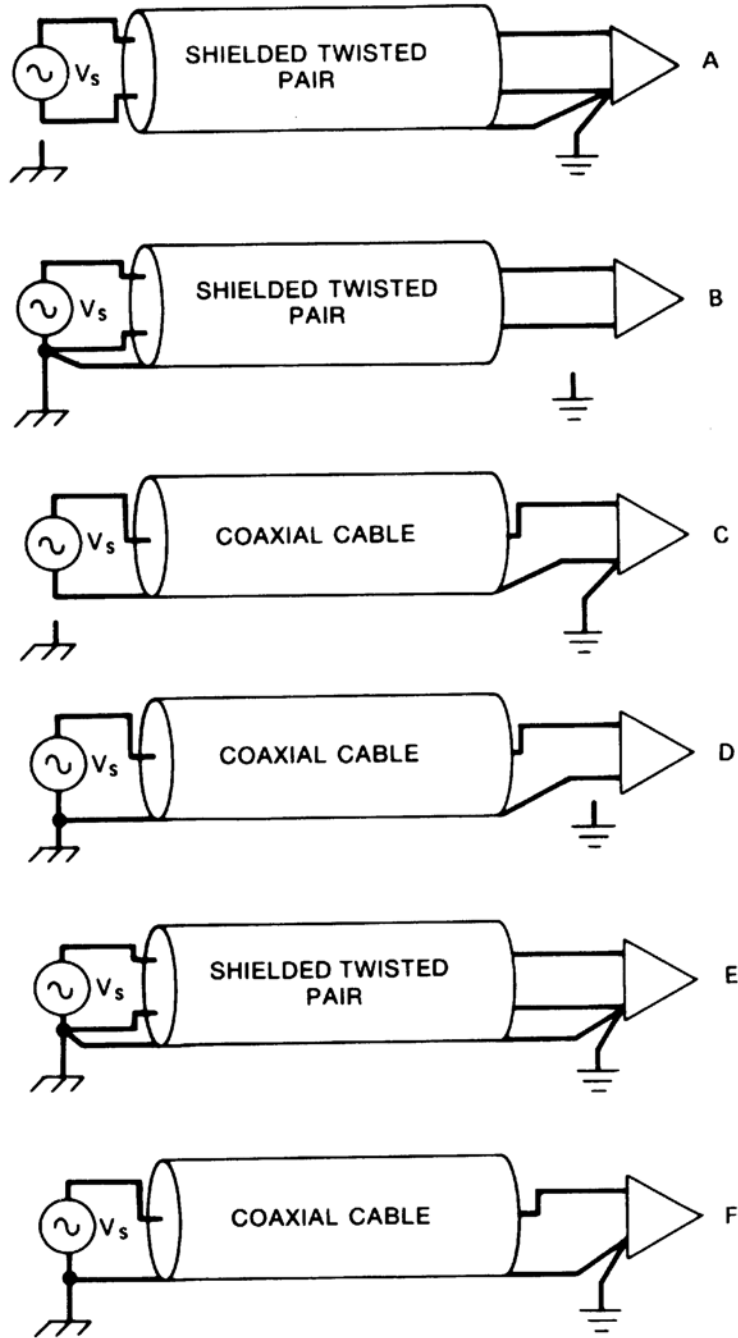

Figure 3-21. Preferred grounded schemes for shielded, twisted pairs and coaxial cable at low frequency.

Ground loops.

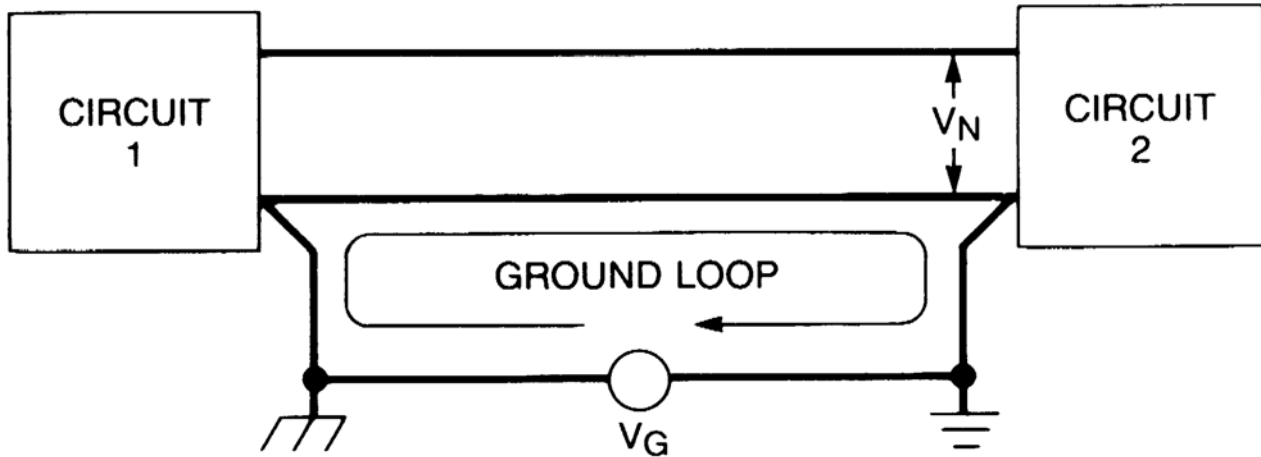

Figure 3-22. *A ground loop between two circuits.*

By “ground loop” we mean a closed loop where the potential ideally should have been at ground all over the loop. However there may be running a current in this loop influencing significantly on the electronic circuitry. There are two main causes for currents in ground loops: The current may be due to magnetic fields or due to large passing currents in part of the ground loop say in a ground plan.

Countermeasures depending on cause:

1. Reduce the size of the loop (if magnetic cause)
2. Route the current in a different direction.

Cause independent countermeasures:

1. Change the system to only one ground connection.

2. "Split" the loop electronically
 - a. transformer
 - b. common mode choke
 - c. optical coupler
 - d. balanced circuit
 - e. frequency selective grounding (hybrid ground).

a) Transformer

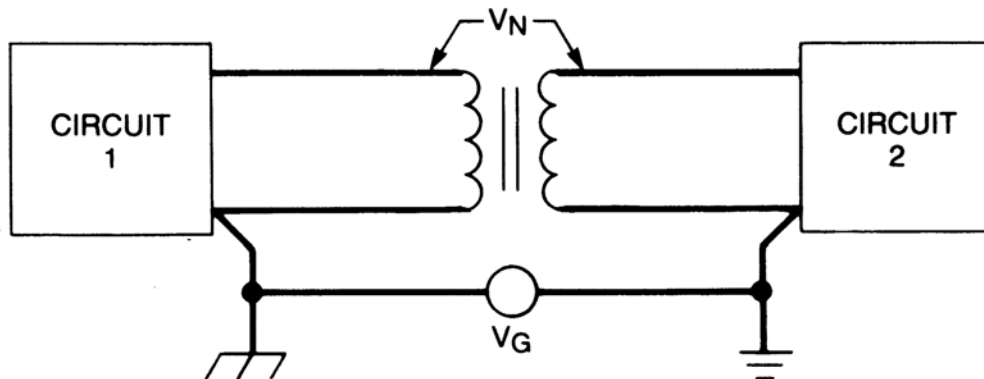

Figure 3-23. A ground loop between two circuits can be broken by inserting a transformer.

The noise is over the trafo and will not influence on the differential voltage. Capacitive coupling may give some noise infection. This coupling may be reduced by shielding the trafo.

b) Common mode choke

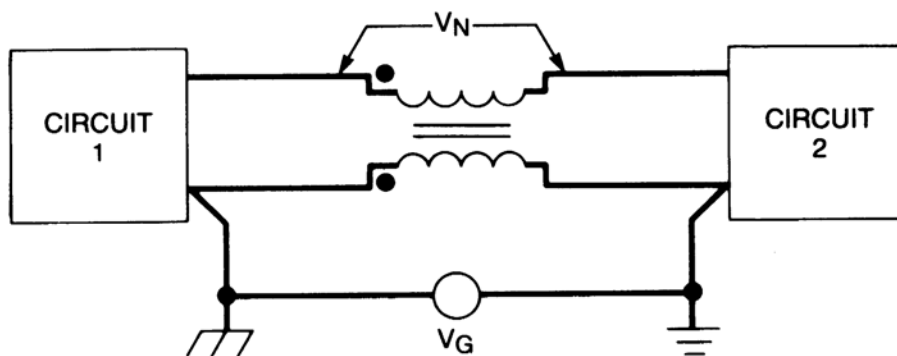

Figure 3-24. A ground loop between two circuits can be broken by inserting a common-mode choke.

(To be discussed in detail a little later.)

c) Optical coupler

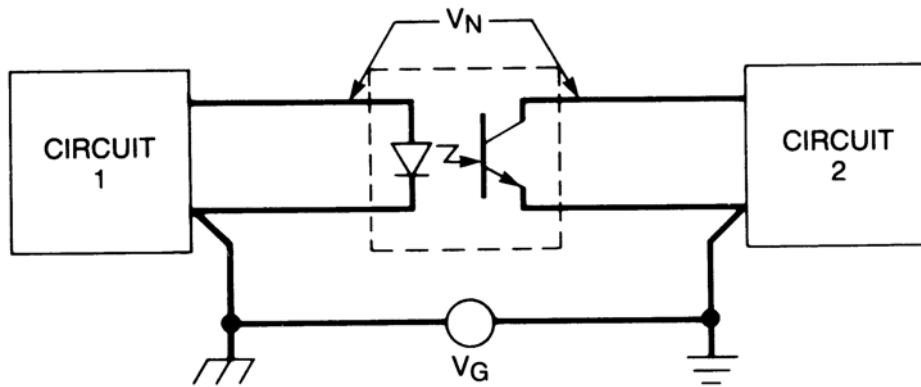

Figure 3-25. An optical coupler can be used to break the ground loop between two circuits.

An attractive alternative when the ground voltage difference is very large. It is better suited for digital circuitry than analogue circuitry due to bad linearity.

d) Balanced circuit

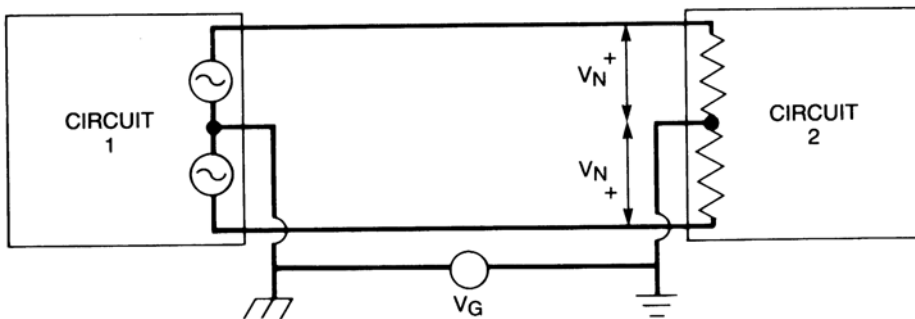

Figure 3-26. A balanced circuit can be used to cancel out the effect of a ground loop between two circuits.

If the ground current was equally divided into the two differential lines, the noise will be eliminated in the receiver. Hence the efficiency will depend on how well symmetry we manage to achieve.

Analysis of Common Mode choke (b)

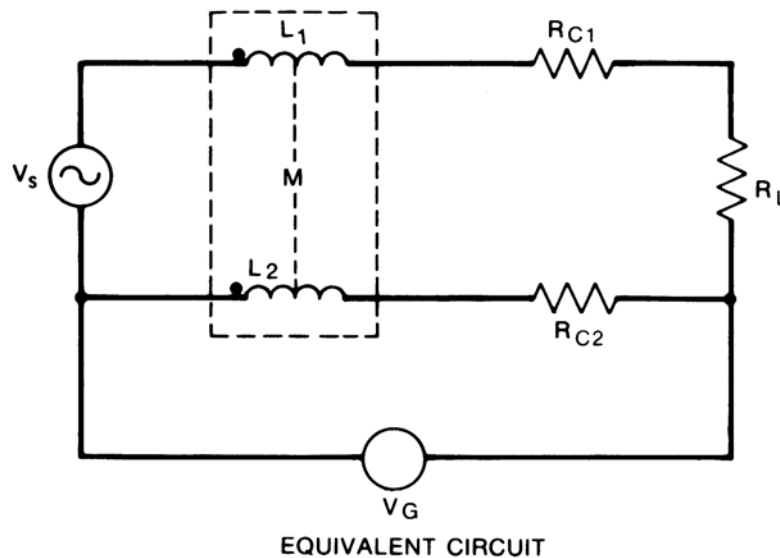
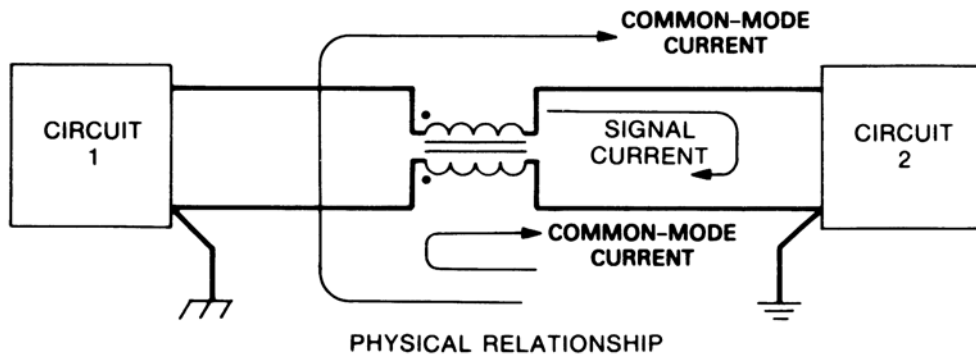

Figure 3-27. When dc or low-frequency continuity is required, a common-mode choke can be used to break a ground loop.

Other names used: longitudinal choke, neutralizing transformer, balun.

Signal current: Current in each direction in the differential pair. Low impedance.

Common mode current: Current in the same direction in both differential conductors. High impedance.

Calculation of signal current:

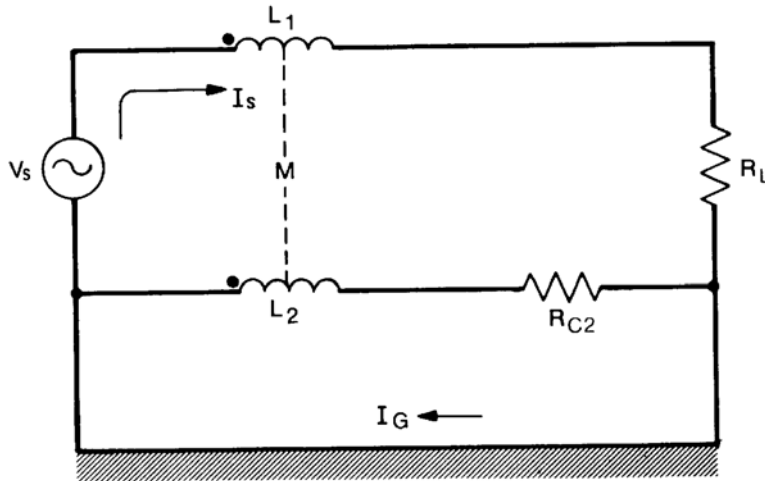

Figure 3-28. Equivalent circuit for Fig. 3-27 for analysis of response to signal voltage V_s .

(Ref: similarities with previous equation (2-22))

When f is over R_{C2}/L_2 most of the return current will pass through the other differential conductor. When f is over $5R_{C2}/L_2$ we have that approximately all current passes through the other line and nothing through ground.

Now we can put up the following equation:

$$V_s = j\omega(L_1 + L_2)I_s - 2j\omega MI_s + (R_L + R_{C2})I_s$$

If the coils are approximately equal and are on the same kernel, we have that:

$$L_1 = L_2 = M$$

Then we have:

$$I_s = \frac{V_s}{R_L + R_{C2}} \approx \frac{V_s}{R_L} \text{ given that } R_L \gg R_{C2}$$

NB! Without choke we get the same expression.

I.e. the choke does not have any influence on the signal current when the frequency is over $5R_{C2}/L_2$. Hence we will try to choose R_{C2} and L_2 so that the corner frequency becomes lower than the lowest possible signal frequency.

Estimates of common noise current:

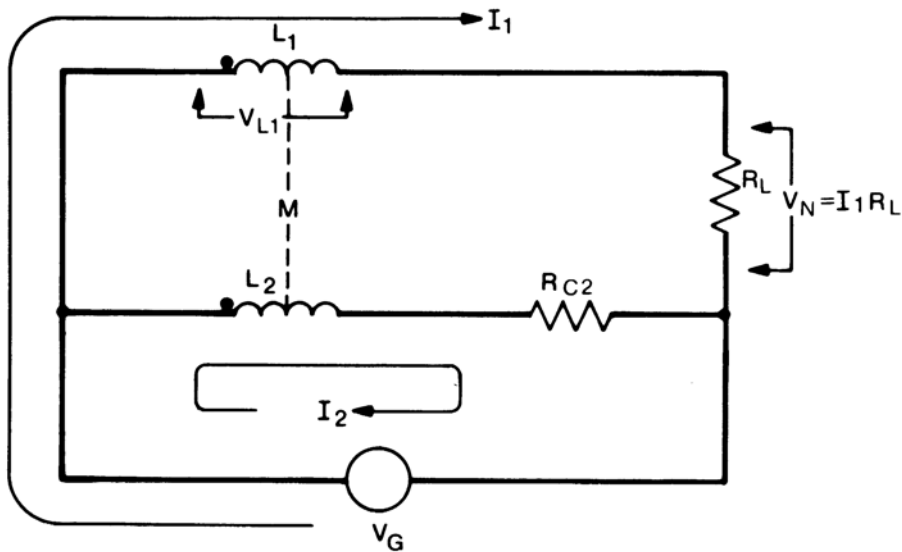

Figure 3-29. Equivalent circuit for Fig. 3-27 for analysis of response to common-mode voltage V_G .

The current in the outer loop is:

$$V_G = j\omega L_1 I_1 + j\omega M I_2 + I_1 R_L$$

while the current in the inner loop is:

$$V_G = j\omega L_2 I_2 + j\omega M I_1 + R_{C2} I_2$$

We find I_2 from the last expression.

$$I_2 = \frac{V_G - j\omega M I_1}{j\omega L_2 + R_{C2}}$$

We still assume $L_1 = L_2 = M$ and include the last expression in the expression for the current in the outer loop and achieve:

$$I_1 = \frac{V_G R_{C2}}{j\omega L (R_{C2} + R_L) + R_{C2} R_L}$$

$$I_1 = \frac{V_G R_{C2}}{j\omega L(R_{C2} + R_L) + R_{C2} R_L}$$

The noise voltage V_N is equal to $I_1 R_L$. Since R_{C2} typically is much less than R_L we may remove the first term in the parenthesis and ends up with:

$$V_N = \frac{V_G R_{C2} / L}{j\omega + R_{C2} / L}$$

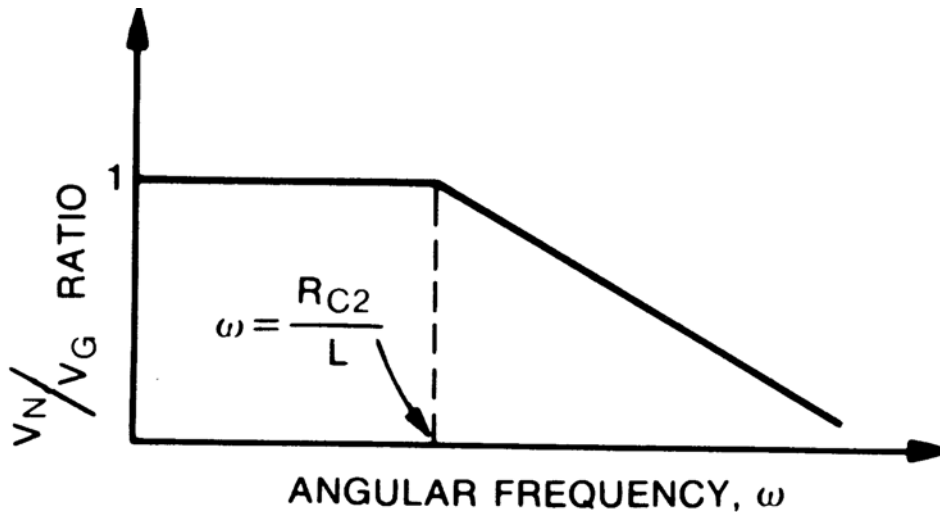

Figure 3-30. Noise voltage may be significant if R_{C2} is large.

To minimize the part of the noise voltage that reaches the "receiver" R_{C2} should be as small as possible and

the choke inductance should be so that $L \gg \frac{R_{C2}}{\omega}$

where ω is the frequency of the noise.

The figure below shows an example of how this can be done.

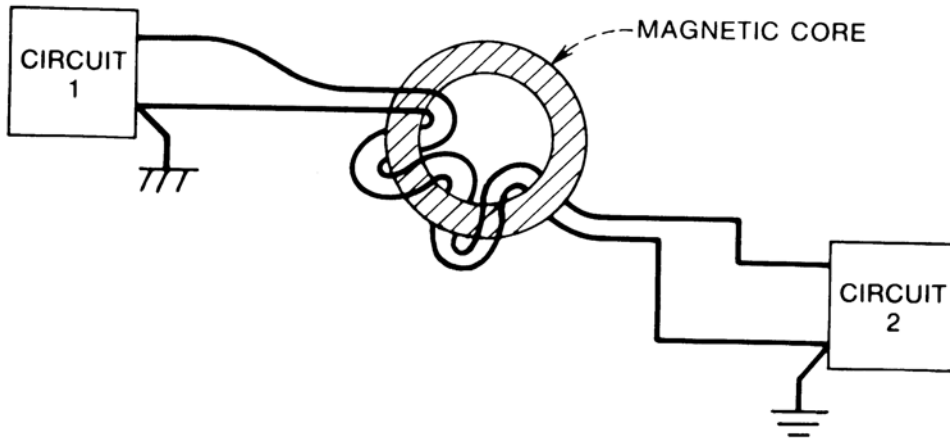

Figure 3-31. An easy way to place a common-mode choke in the circuit is to wind both conductors around a toroidal magnetic core. A coaxial cable may also be used in place of the conductors shown.

Differential amplifiers

Differential amplifiers (top figure below) have less sensitivity to common mode noise. However it is also possible to achieve this with a single sided amplifier if connected as shown in the bottom figure below.

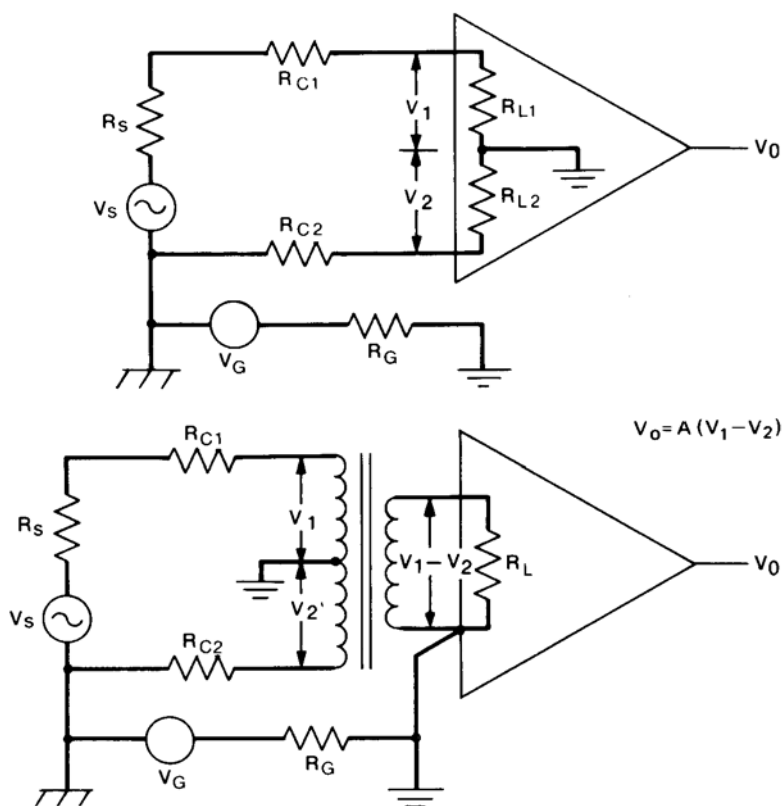
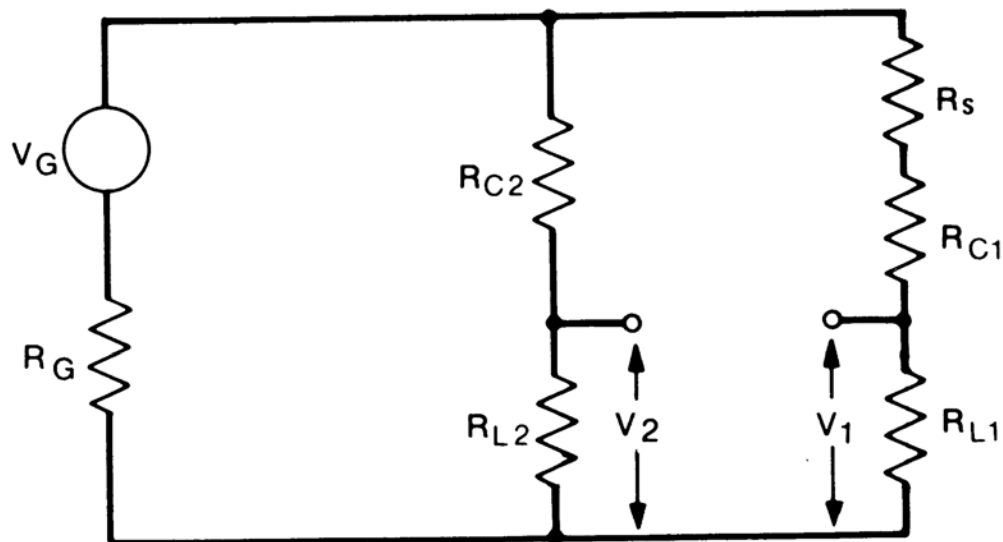

Figure 3-35. A differential amplifier—or a single-ended amplifier with transformer—can be used to reduce the effects of a common-mode noise voltage.

Both the real differential and the one based on the single sided amplifier can be represented by the same equivalent schematic and the same equation.



EQUIVALENT CIRCUIT

Figure 3-36. Equivalent circuit for analysis of differential-amplifier circuit.

R_{L1} and R_{L2} represents the resistors with the same name in the differential amplifier. In the trafo-balansed amplifier they both represent R_L mirrored through the trafo.

If we assume that R_{L2} is much larger than R_G we can simplify to the following equation:

$$V_N = V_1 - V_2 = \left(\frac{R_{L1}}{R_{L1} + R_{C1} + R_S} - \frac{R_{L2}}{R_{L2} + R_{C2}} \right) V_G \quad \mathbf{Exa}$$

mple:

$$V_G = 100\text{mV}$$

$$R_G = 0.01\Omega$$

$$R_S = 500\Omega$$

$$R_{C1} = R_{C2} = 1\Omega$$

$$\text{If } R_{L1} = R_{L2} = 10\text{k}\Omega \text{ then } V_N = 4.6\text{mV}$$

$$\text{If } R_{L1} = R_{L2} = 100\text{k}\Omega \text{ then } V_N = 0.5\text{mV}$$

Larger R_L and/or smaller R_S is attractive.

It is possible to increase the input impedance for the common mode signal without increasing the impedance experienced by the differential signal. This can be achieved by inserting a resistance R as drawn in the figure below.

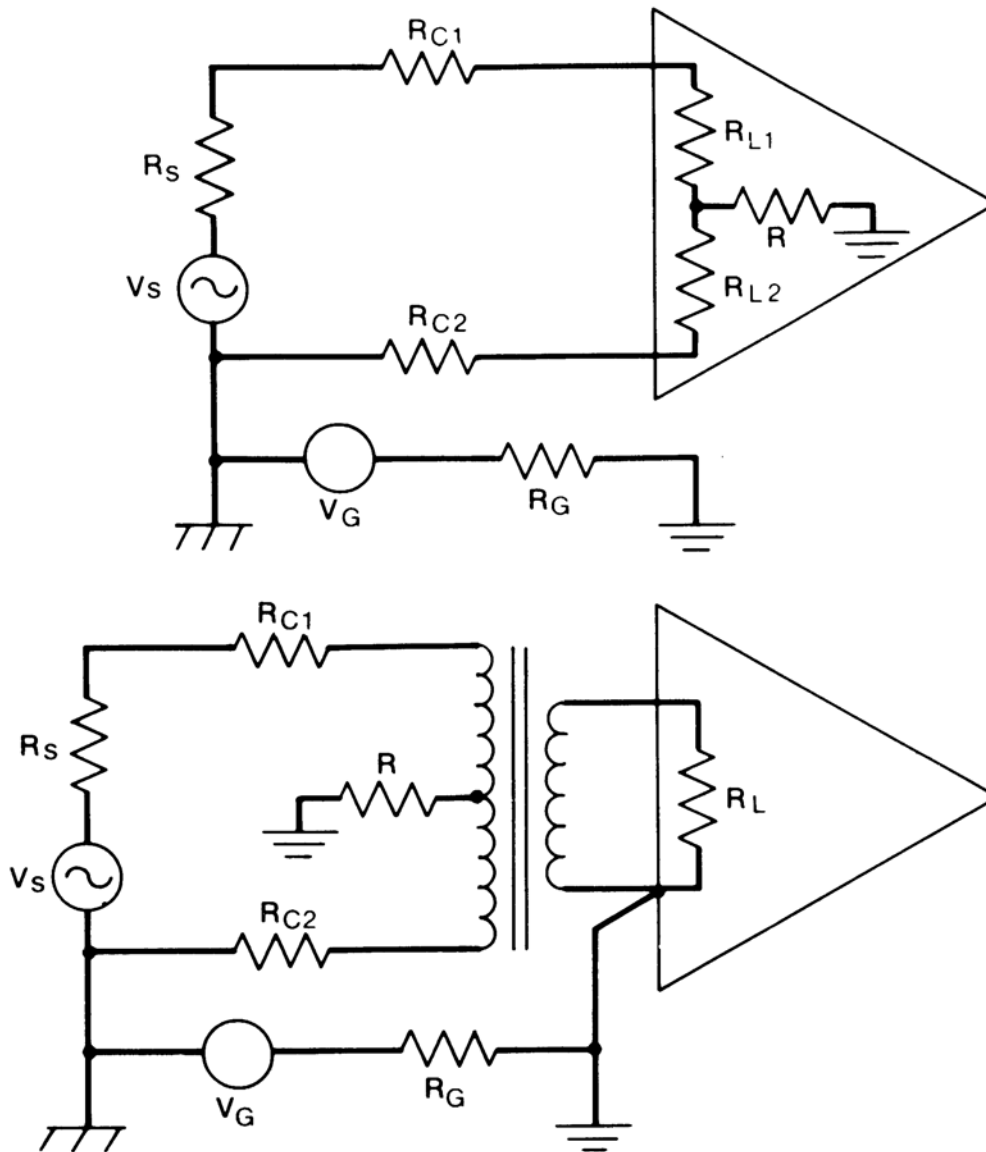

Figure 3-37. Insertion of resistance R into ground lead decreases the noise voltage.

Shield grounding at higher frequencies

Theoretically a one point ground is preferably from reasons discussed earlier. At higher frequencies, due to shield impedance and other capacitive couplings, grounding, grounding of shields at several positions may be preferred to ensure acceptable ground potential.

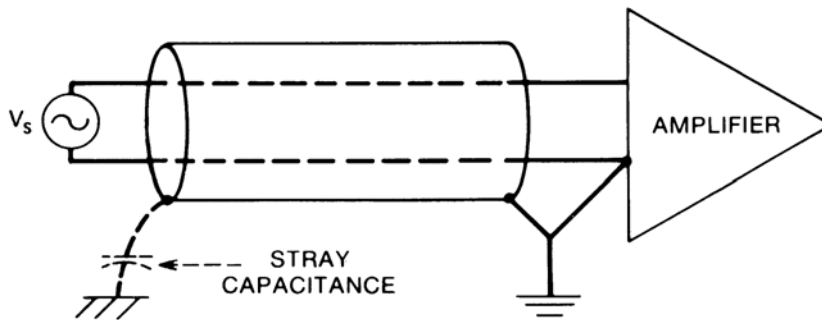

Figure 3-38. At high frequencies stray capacitance tends to complete the ground loop.

This may be done by using a full grounding in one point and add capacitors along the cable to ensure grounding at higher frequencies through an AC-coupling.

Guard shields

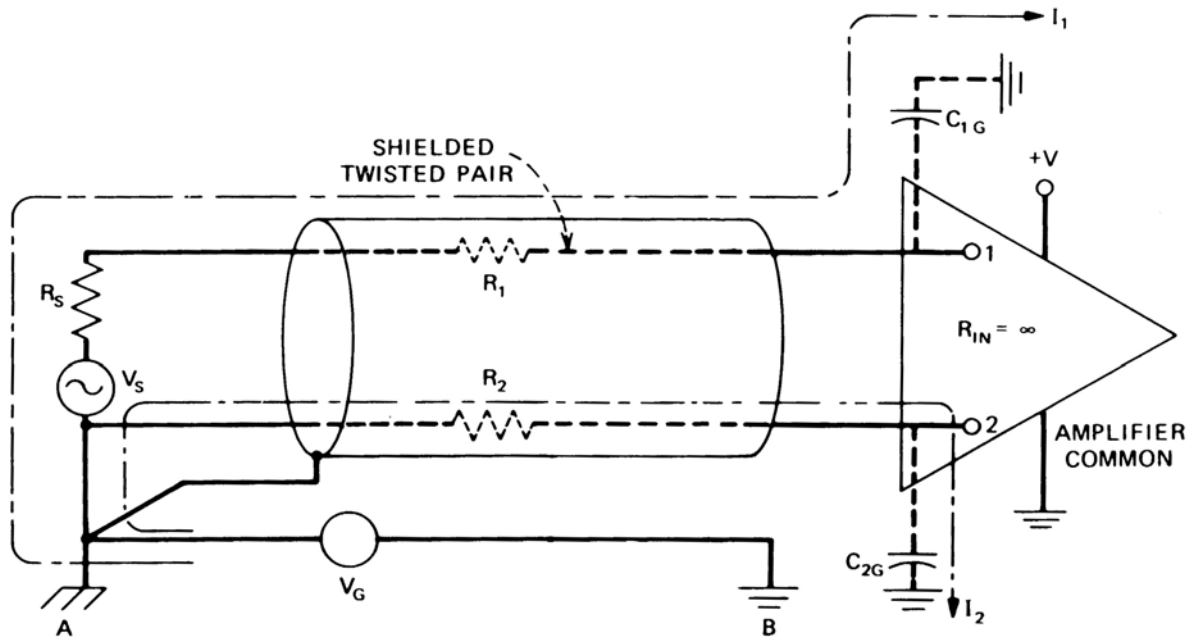

Figure 3-39. Amplifier and a grounded source are connected by a shielded twisted pair.

In general we have that $(R_S + R_1 + XC_{1G}) \ll (R_2 + XC_{2G})$. The difference in the ground potential V_G will result in two different currents through the differential pair and thus two different voltage drops over XC_{1G} and XC_{2G} even though XC_{1G} and XC_{2G} are equal. To make the currents equal $(R_S + R_1 + XC_{1G}) = (R_2 + XC_{2G})$ at the same time as $XC_{1G} = XC_{2G}$. A simpler solution is to try to make the voltage drop over the differential wires equal to 0V. If so the voltage drop over the inputs become equal (i.e.

0Volt).

$$V_{in}(x) = \frac{Z_{in}(x)}{Z_{in}(x) + Z_{rest}(x)} V_{fellesstøy}$$

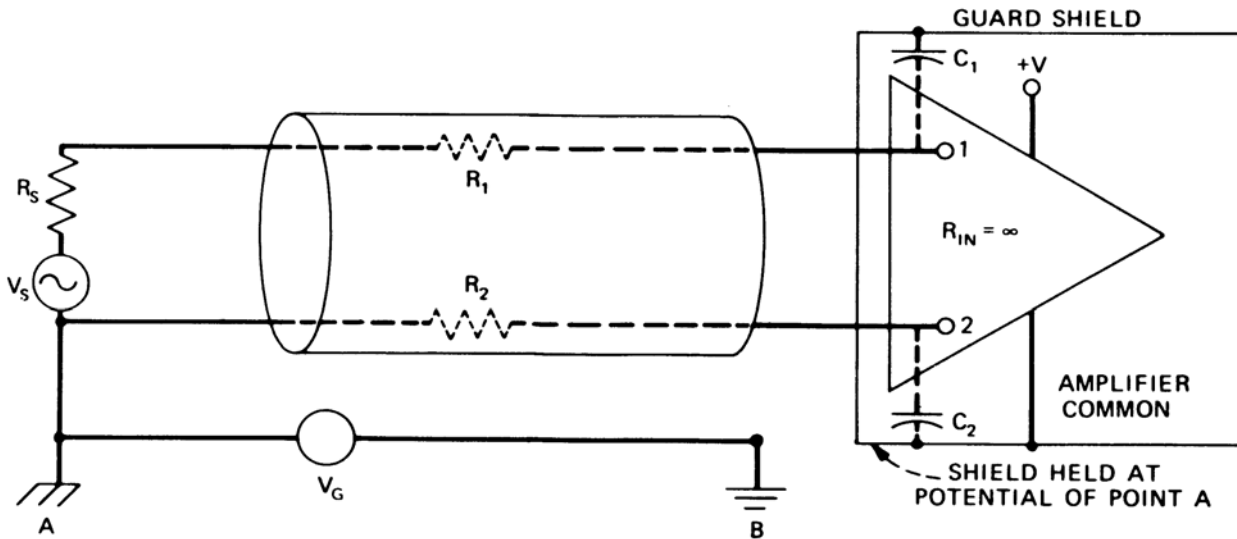

Figure 3-40. *Guard shield at potential of point A eliminates noise currents.*

In the solution drawn above we have a screen encapsulating the amplifier. The shield is connected so that it has the same ground potential as the source (point A). In this way the ground voltage drop will be zero from point A, through the differential wires and through the amplifier input towards the shield.

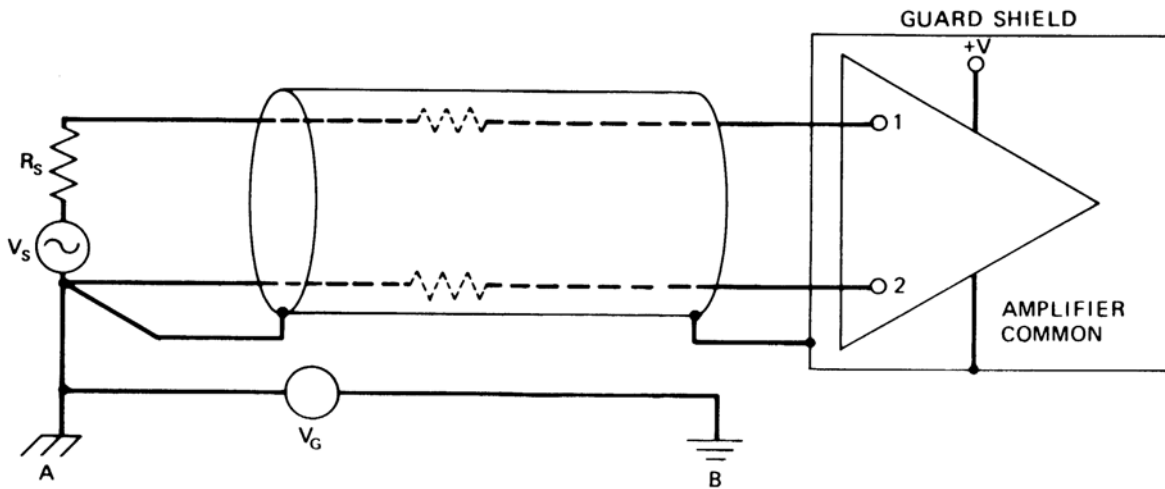

Figure 3-41. *Guard shield is connected to point A through the cable shield.*

The figure illustrates how the amplifier shield can be connected to point A via the cable shield.

The amplifier power source can not refer to point B. Possible power options are via cable from A, having an independent power source (say a battery) or coupled via a galvanic element to the power source on the right side.

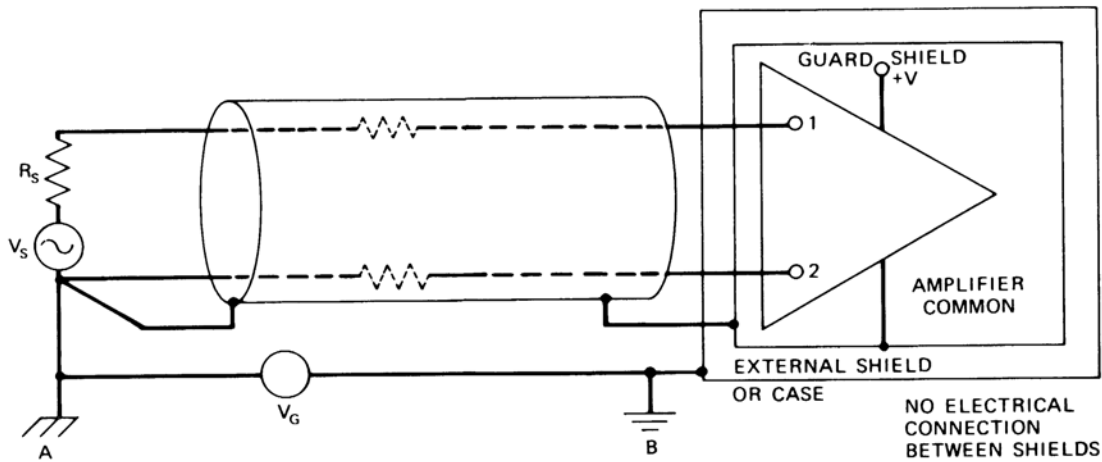

Figure 3-42. Practical circuit often has a second shield around the guard shield.

If it is likely/a possibility that the screen encapsulating the amplifier can pick up noise from the surroundings a double shield may be a possibility. In this case the outer shield is grounded locally and it is also important that the impedance between the two shields are high enough compared with the other influencing impedances in the system.

Example:

$$V_G = 100\text{mV at } 60\text{Hz}$$

$$R_1 = R_2 = 0$$

$$R_S = 2.6\text{k}\Omega$$

$$C_{1G} = C_{2G} = 100\text{pF} \Rightarrow X_C = 26\text{M}\Omega \text{ at } 60\text{Hz}$$

a) Without amplifier shield

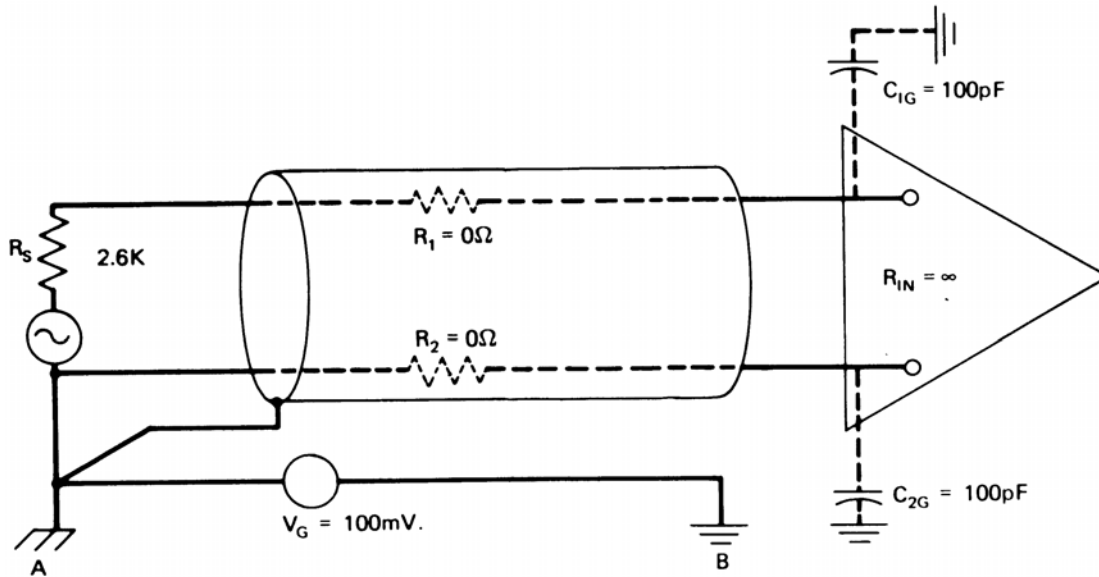

Figure 3-43. Numerical example to illustrate need for guard shield.

$$V_N = \left(\frac{R_S + R_1}{R_S + R_1 + Z_{1G}} - \frac{R_2}{R_2 + Z_{2G}} \right) V_G$$

Given the values above we achieve:

$$\underline{V_N = 10\mu\text{V}}$$

b) With amplifier shield:

Assume that the shield results in a change of C_{1G} and C_{2G} from 100pF to 2pF. We may use the same expression as above and now have:

$$V_N = 0.2 \mu V$$

i.e. now an attenuation of 34 dB

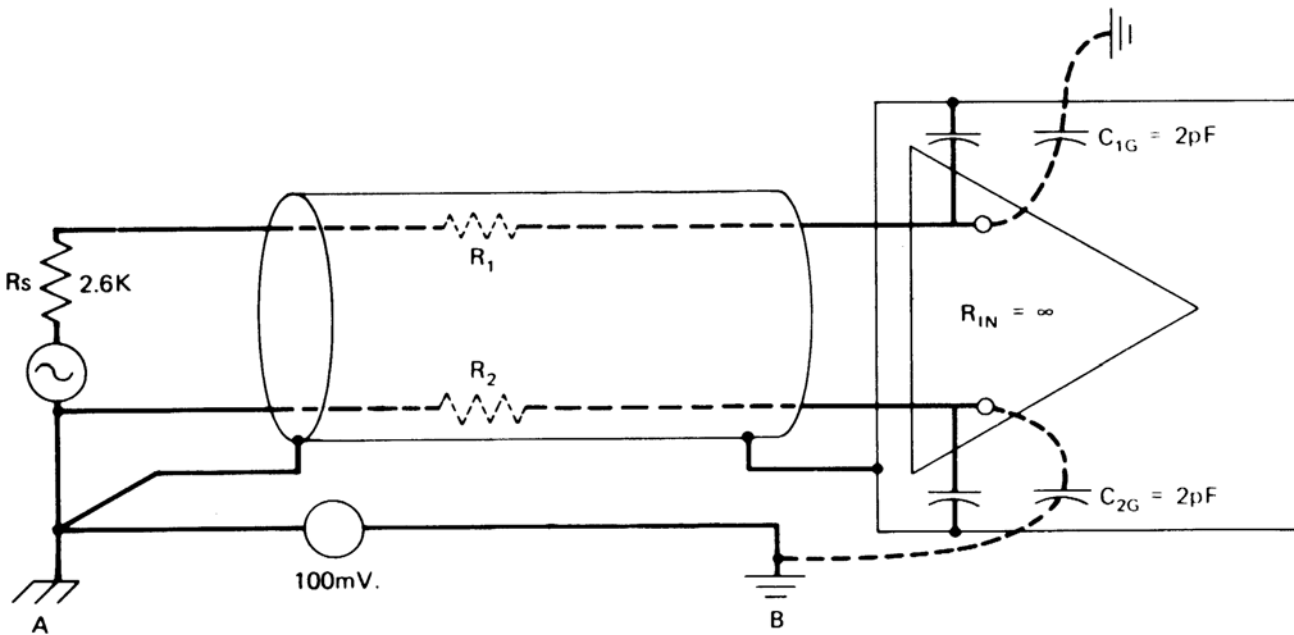

Figure 3-44. Guard shield reduces line capacitance to ground and therefore noise voltage.

Measuring apparatus with "Guard". Discussion of alternative connections.

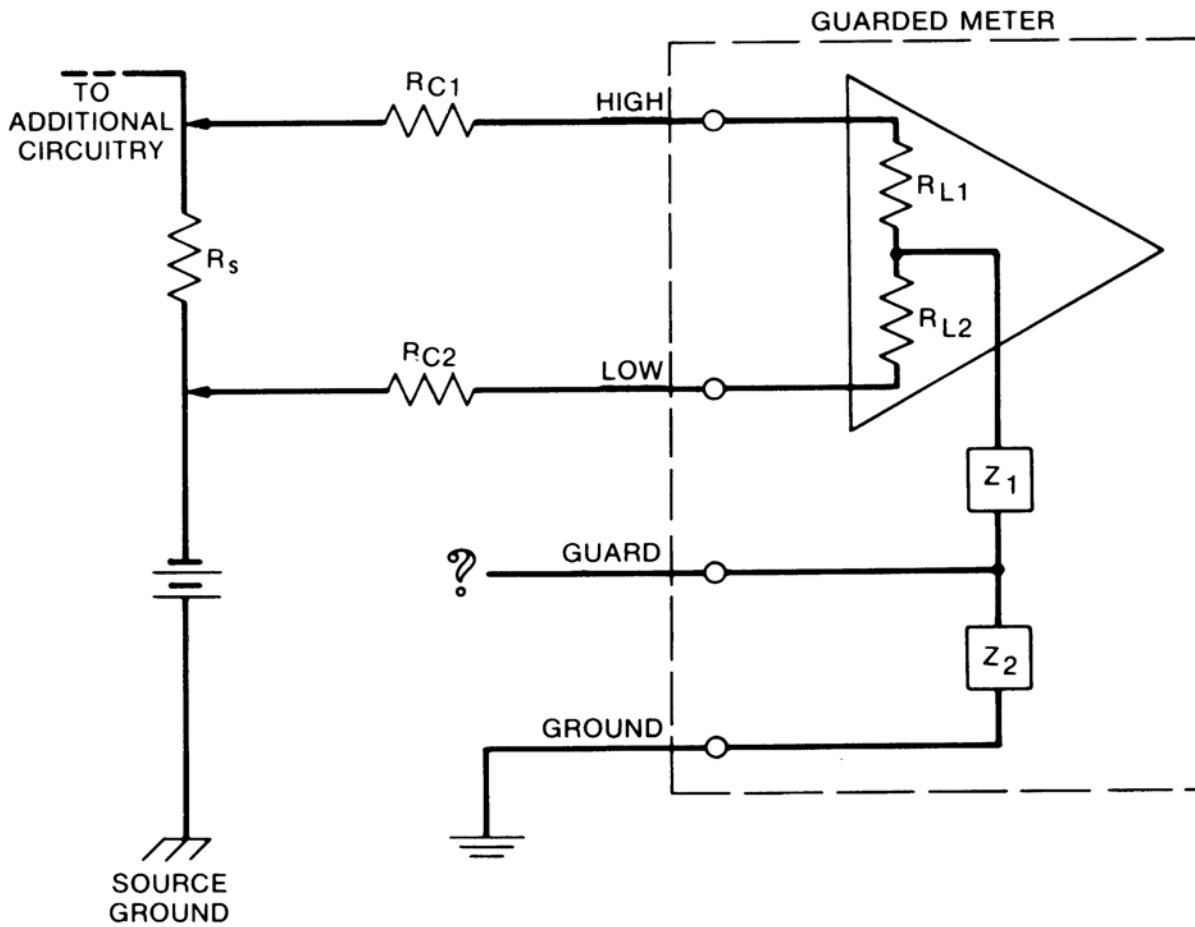

Figure 3-45. When a guarded meter is used, a common problem is where to connect the guard terminal.

How to connect "Guard" to achieve the best possible measuring results?

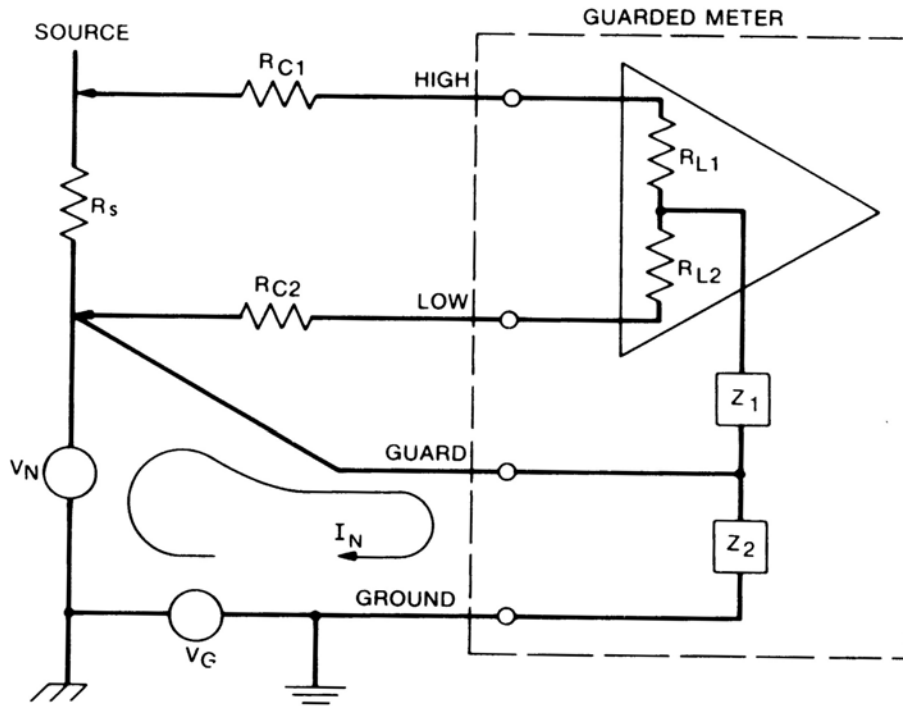
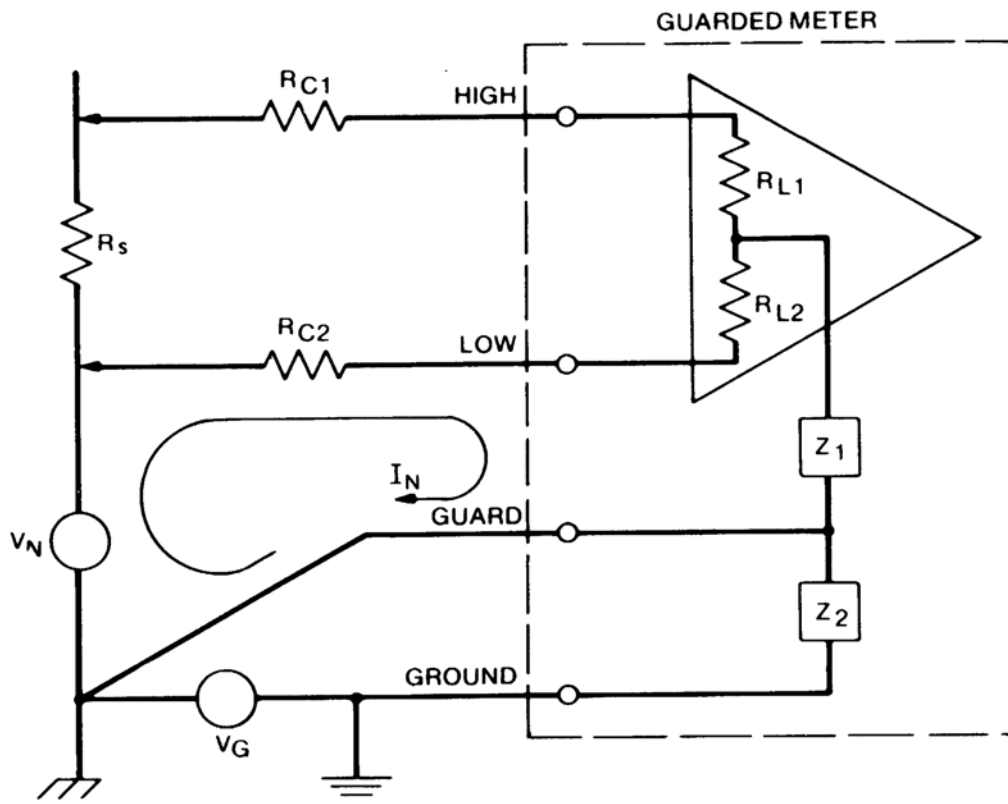

Figure 3-46. When measuring voltage across R_s , best connection for the guard is to the low-impedance side of R_s ; noise current does not affect amplifier.



PROTECTION AGAINST V_G ONLY.

Figure 3-47. Guard connected to source ground gives no protection against V_N .

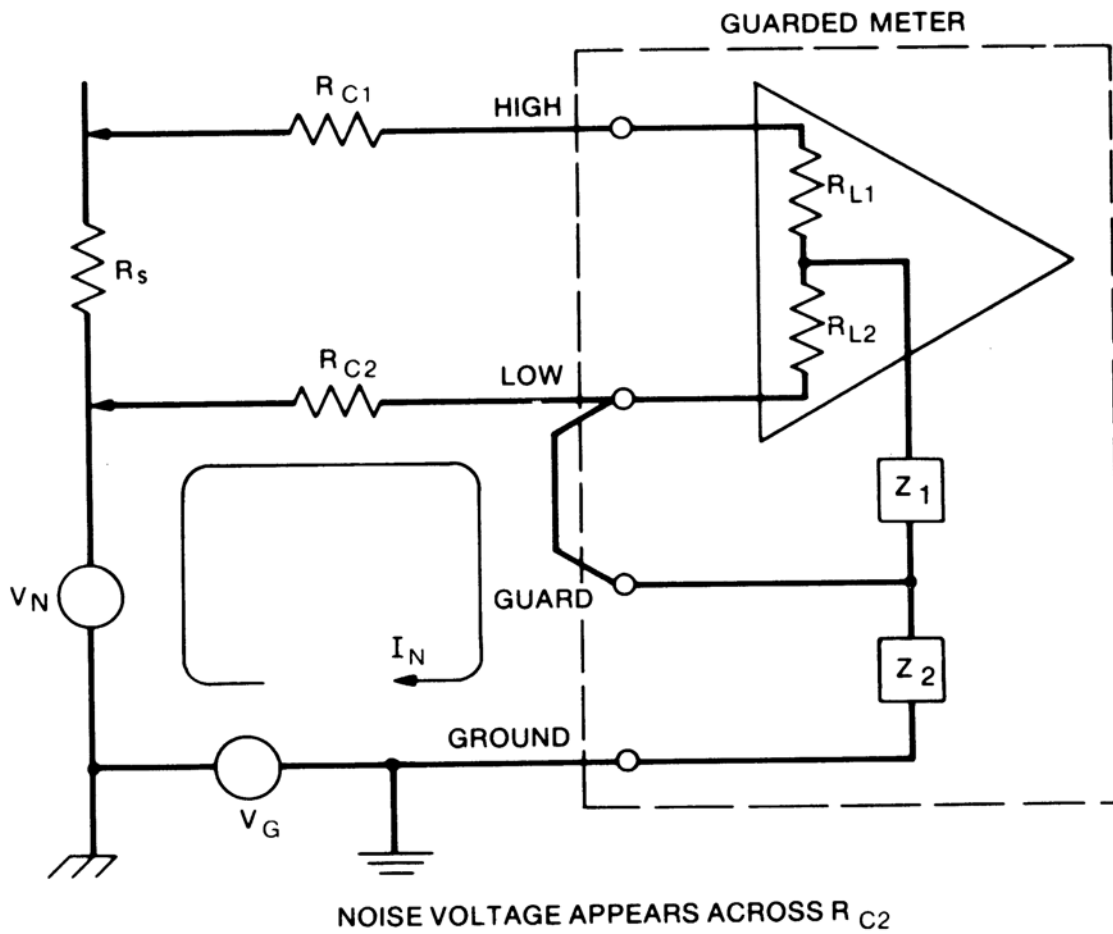
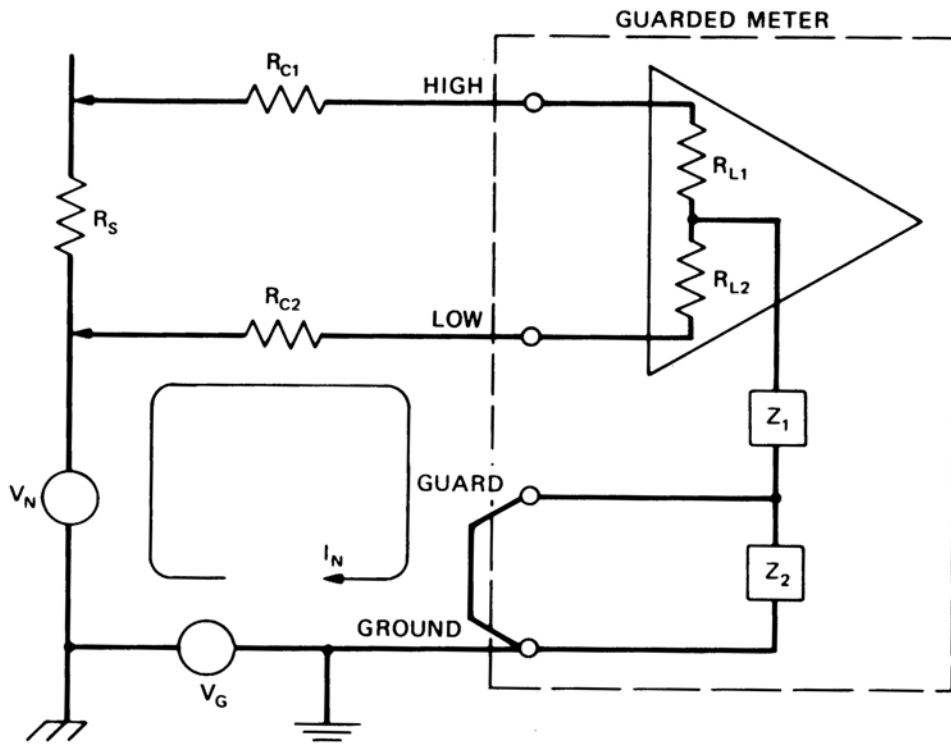

Figure 3-48. Guard connected to low side of meter allows noise current to flow in line resistance R_{C2} .



NOISE VOLTAGE APPEARS ACROSS R_{C2} AND R_{L2}

Figure 3-49. Guard connected to local ground is ineffective; noise current flows through R_{C2} , R_{L2} , and Z_1 .

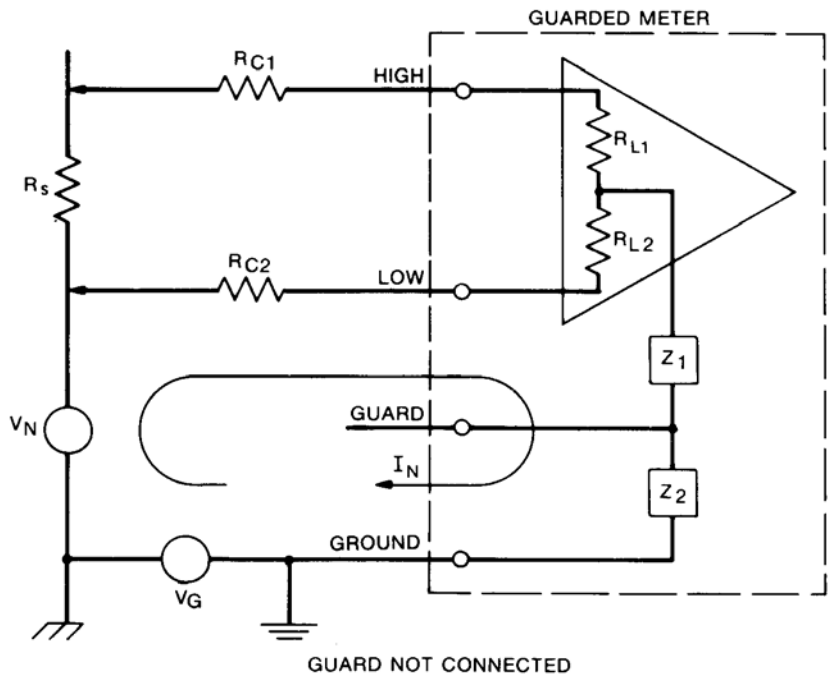

Figure 3-50. Guard not connected; noise currents due to V_N and V_G flow through R_{C2} , R_{L2} , Z_1 , and Z_2 .