

Frekvensfilter

Kap. 23

Filtre kan inndeles i mange grupper – vi skal se på noen av de mest brukte. Noen navn beskriver teknologien bak filteret – andre navn beskriver frekvensområdet hvor filteret arbeider :

- Aktive og passive filtre.
- Bredbånd og smalband filter (tuned filter)
- Lavpass og høypass filter
- Bånd- stopp – eller Notch filter

Tuned filter - smalbandfilter

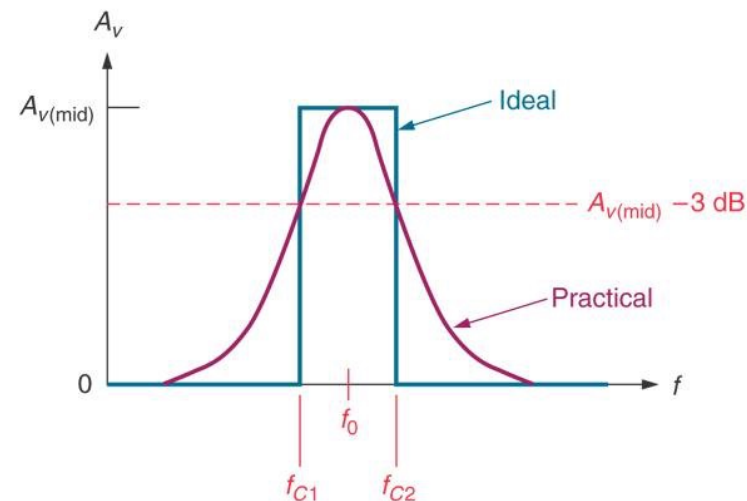

Frekvensfilter

Filter terminologi

Litt filterterminologi :

Aktivt filter er en filterkrets hvor operasjonsforsterkere inngår.

Vi har fire (4) hovedtyper av filtere :

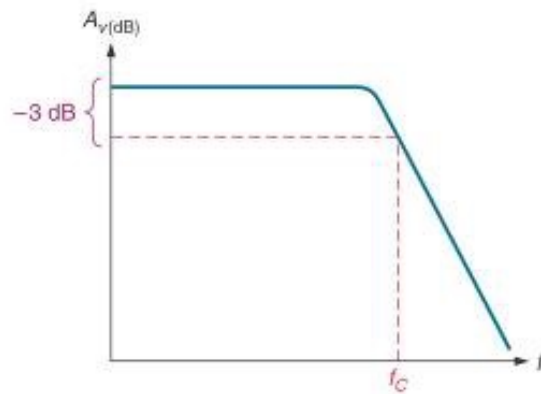

(a) Low-pass

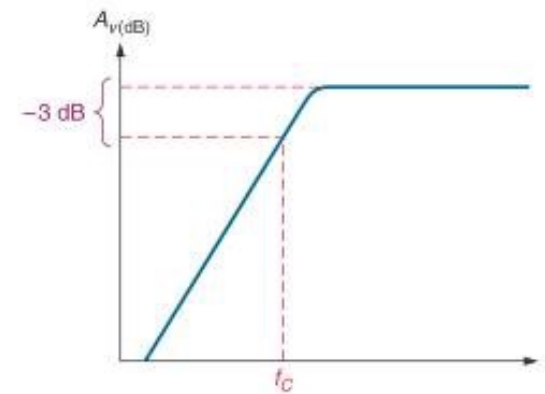

(b) High-pass

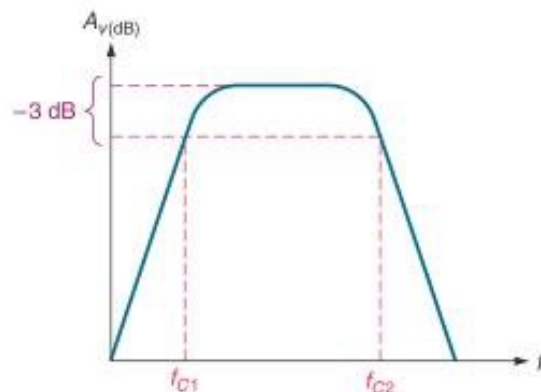

(c) Bandpass

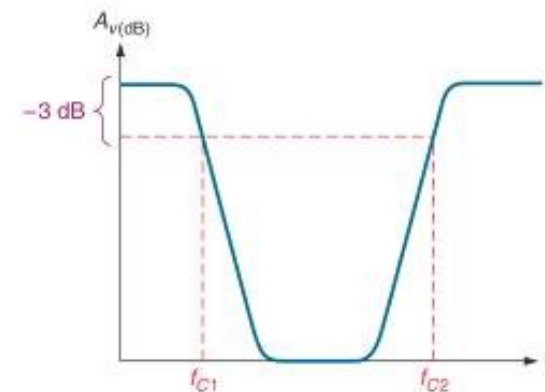

(d) Band-stop (notch)

Frekvensfilter

Q-verdi

Q - verdien bestemmer båndbredden til filteret. Høy Q-verdi = smal båndbredde ($Q = \text{Quality factor}$)

$$Q = \frac{f_0}{\text{BW}}$$

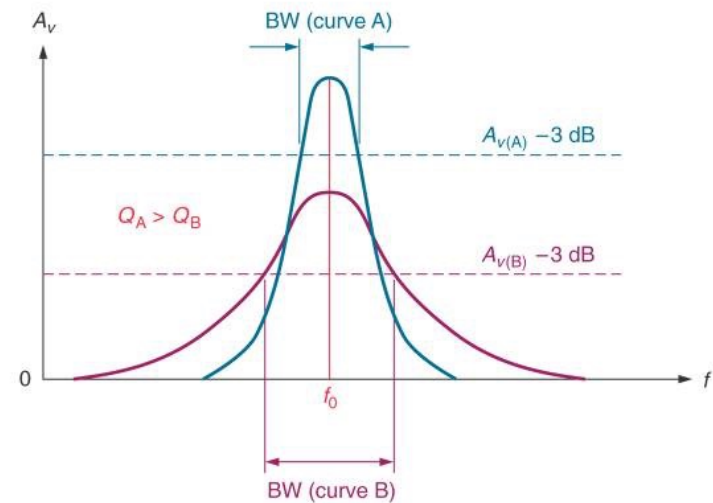

Geometrisk senterfrekvens f_0

$$f_0 = \sqrt{f_{C1} f_{C2}}$$

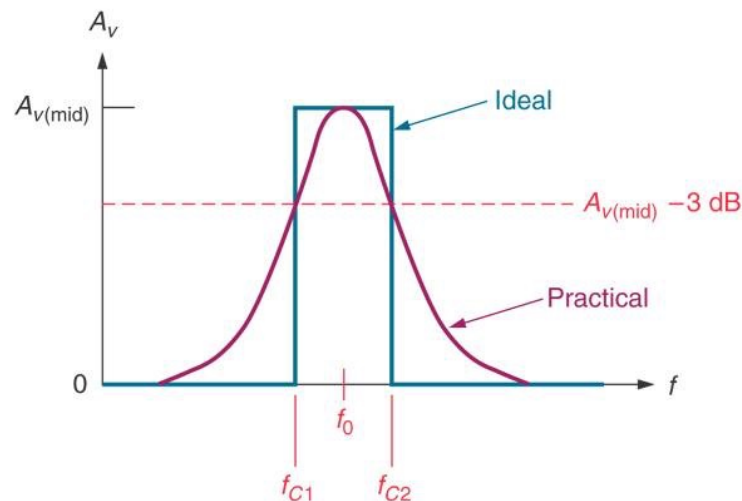

Frekvenskravet til filteret må være klart definert

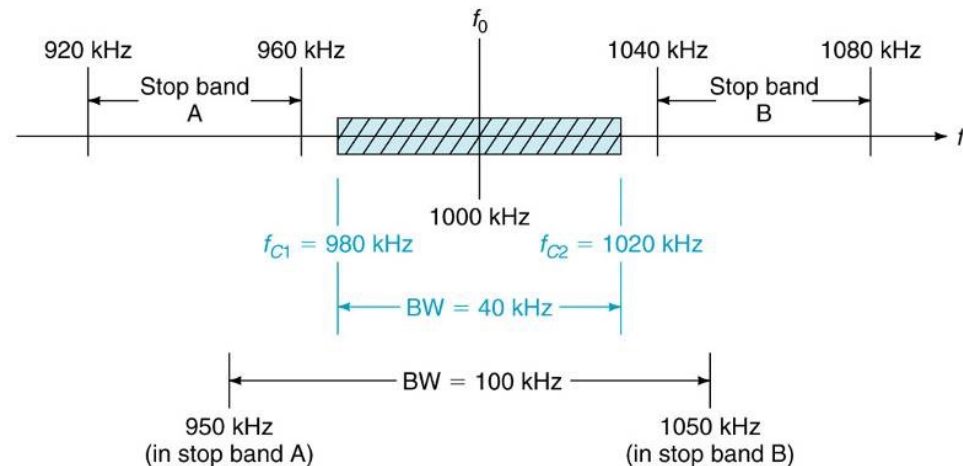

Frekvensfilter

Filter terminologi

- Mer filter- terminologi - poler og orden
 - **Pol**
 - En RC- krets
 - Eksempel: Filter med en pol: - filtret inneholder en RC- krets
 - **Orden**
 - Brukes for å beskrive antall poler
 - Eksempel: første ordens filter: inneholder en pol
 - **Flere poler** – steilere “Roll-off”-flanke

*Butterworth
Første ordens
filter. Flanken
faller med 20
dB/dekade –
6 dB pr. oktav*

Filter Type	Antall poler	Total Gain Roll-Off
First-order	1	20 dB/decade
Second-order	2	40 dB/decade
Third-order	3	60 dB/decade

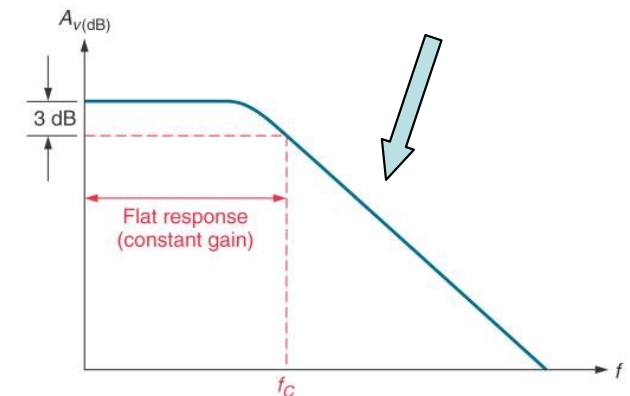

Frekvensfilter

Ulike filter typer

Butterworth, Chebyshev, og Bessel Filter

- Butterworth (maximally flat or flat-flat) – har en relativt flat respons over pass-båndet
- Butterworth – det mest bruket av aktive filtre

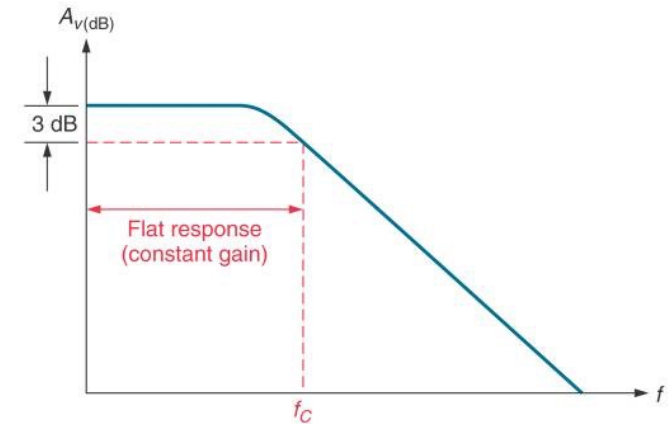

Chebyshev – Har brattere “roll-off rate”

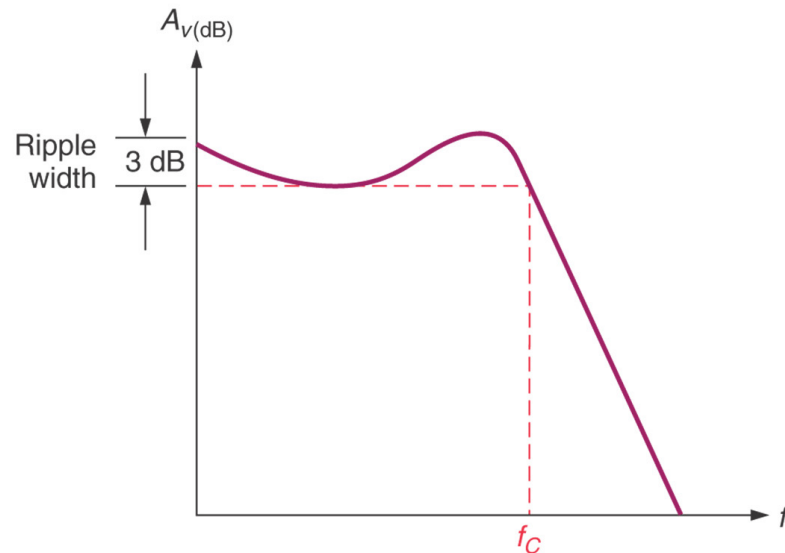

(a) A Chebyshev response curve

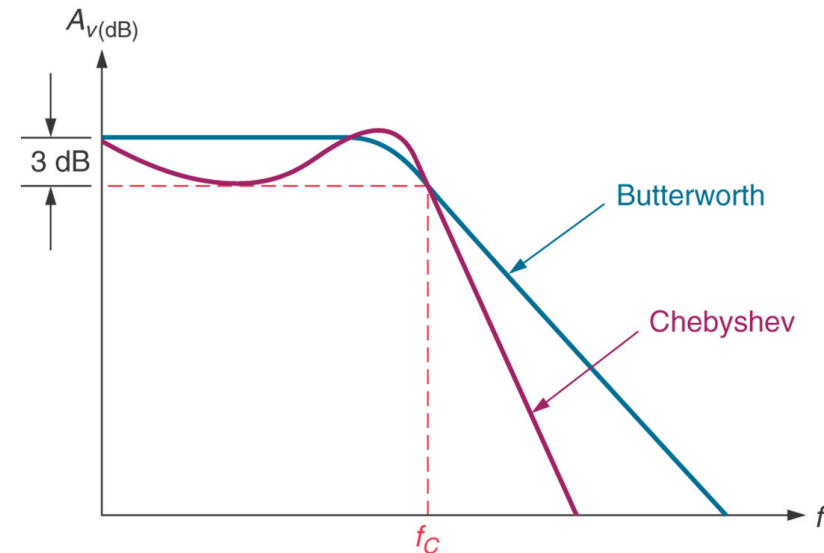

(b) Response curves for comparable Chebyshev and Butterworth filters

Frekvensfilter

Ulike filter typer

- Butterworth, Chebyshev, og Bessel Filters
- - Chebyshev - brattest “roll-off rate” - men har “rippel” i pass-båndet
 - Bessel – filter som gir konstant faseskift over hele pass-båndet
 - Butterworth – filter med maksimalt flat respons

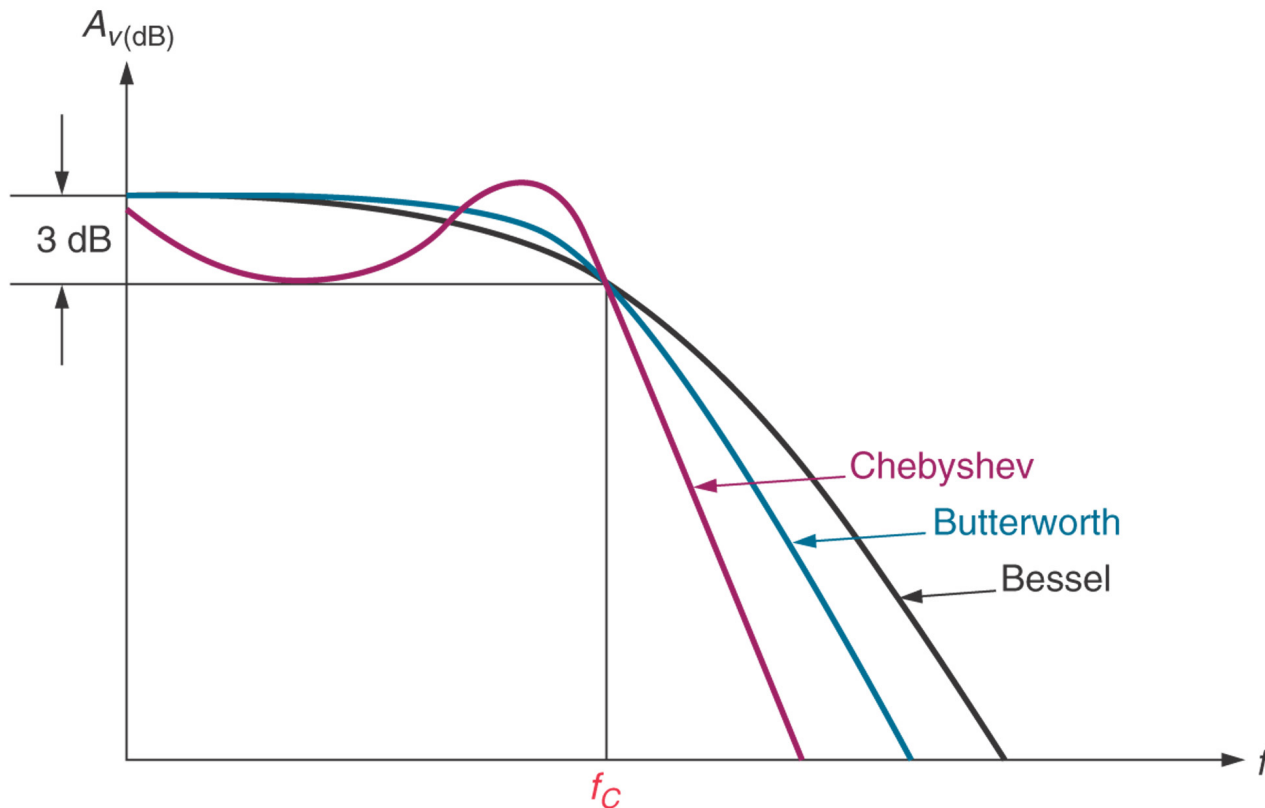

Frekvensfilter

Butterworth

En pol – Lavpass filter – med eller uten forsterkning – type Butterworth

$$f_c = \frac{1}{2\pi RC}$$

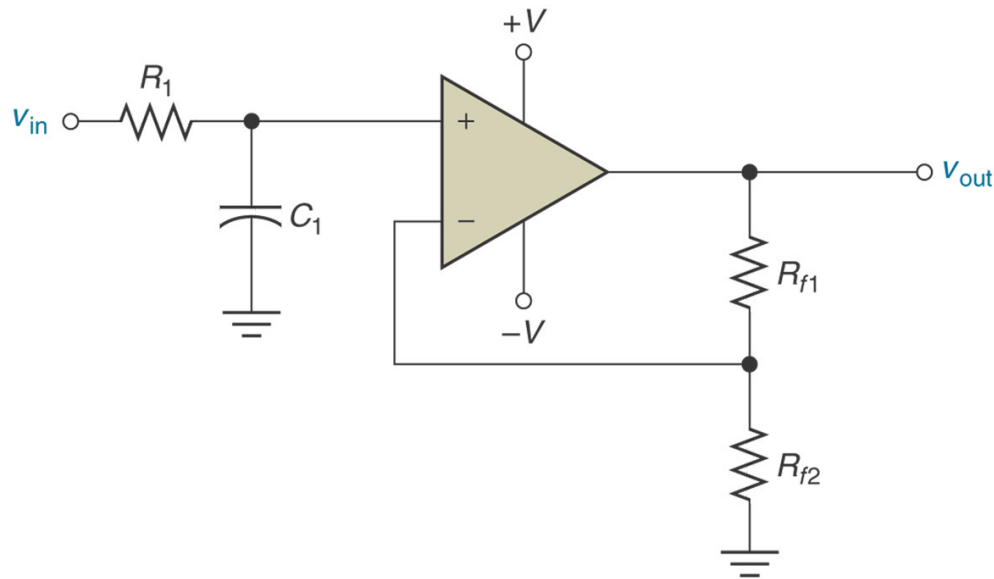

(a) Variable-gain circuit

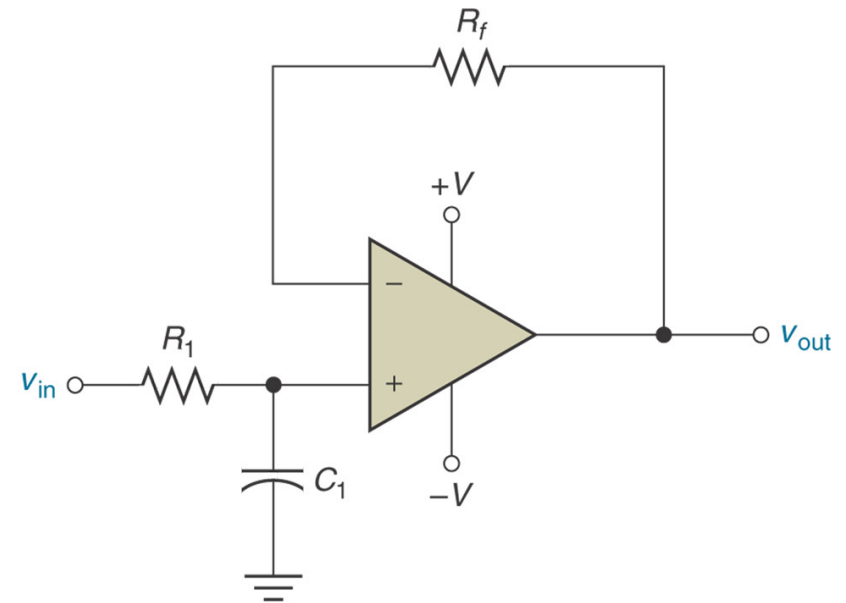

(b) Unity-gain circuit

Frekvensfilter

Butterworth

Butterworth lavpass filter med 2 poler – faller med -40dB/dekade

$$f_c = \frac{1}{2\pi \sqrt{R_1 R_2 C_1 C_2}}$$

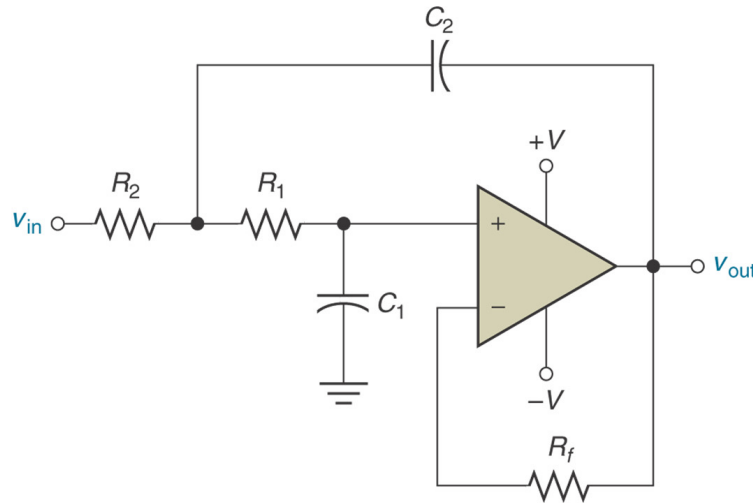

(a) Unity-gain filter

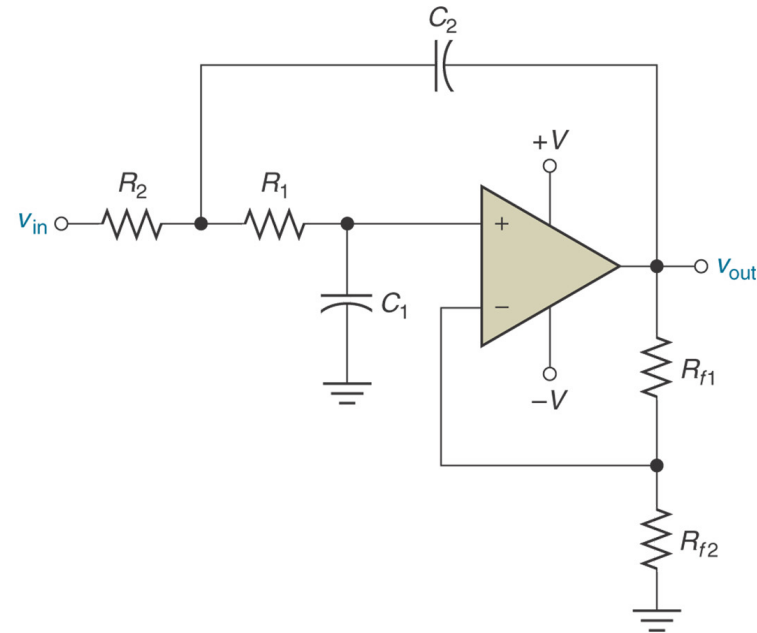

(b) Variable-gain filter

Frekvensfilter

Høypass filter – en og to poler - *Butterworth*

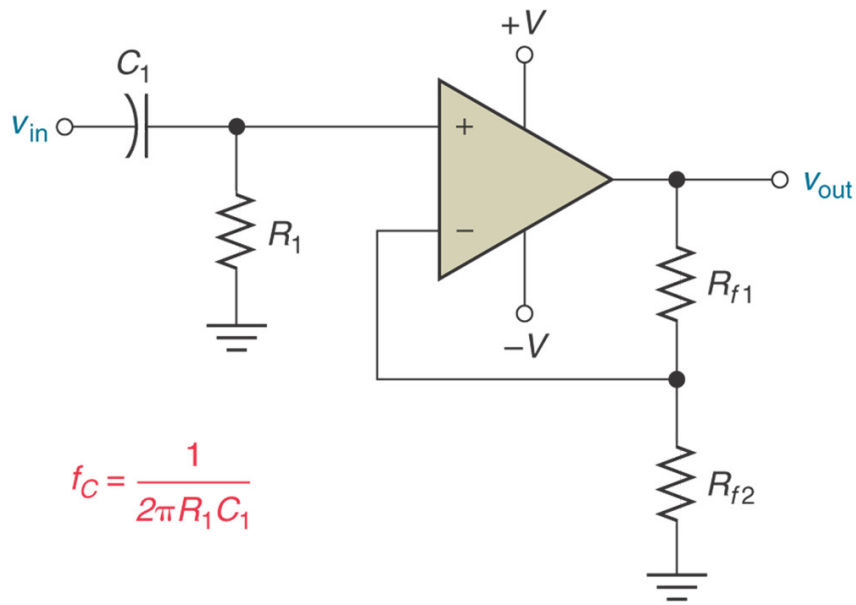

(a) One-pole

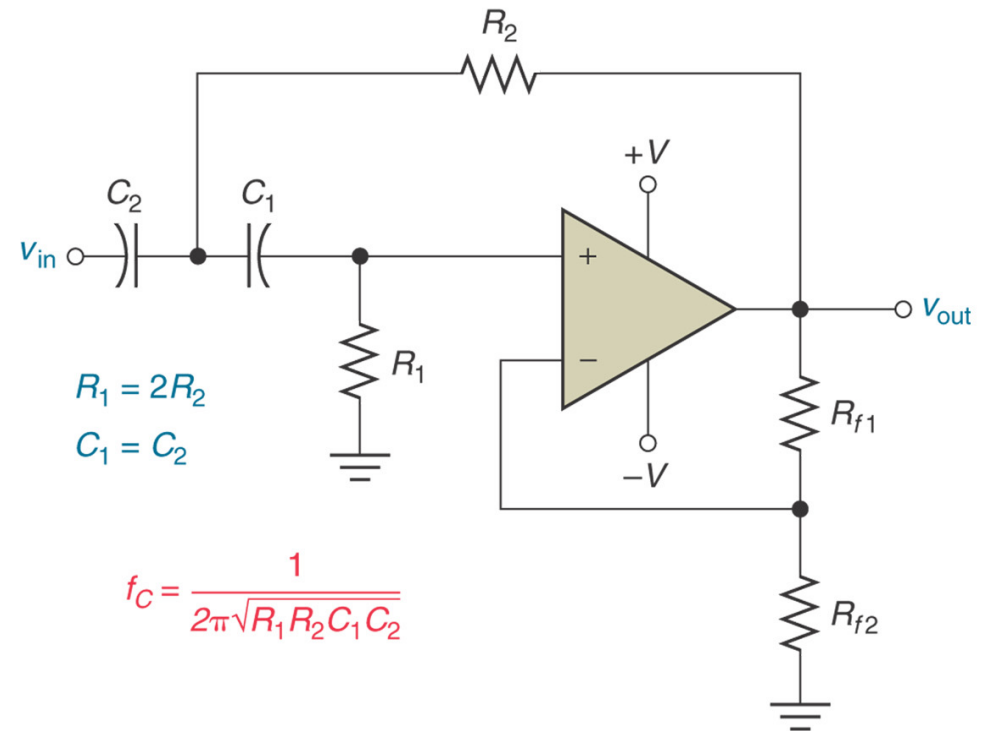

(b) Two-pole

Frekvensfilter

To trinns Båndpass- og Notch-filter – kaskadekopling av filtre
 Først lavpass- så følger høypassfilter

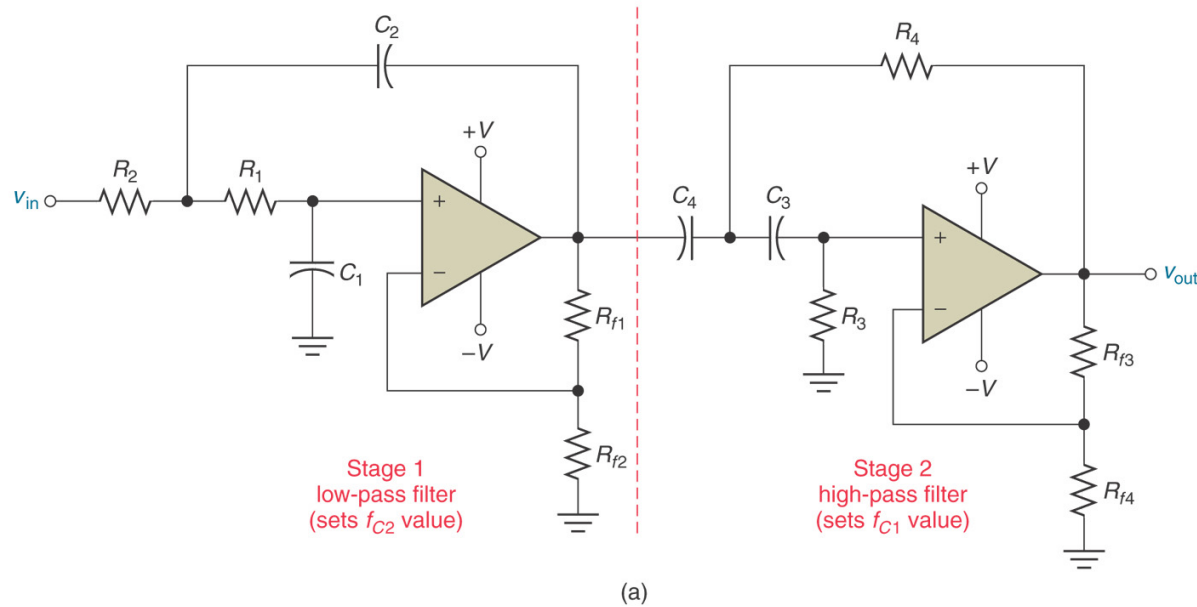

$$BW = f_{C2} - f_{C1}$$

$$f_0 = \sqrt{f_{C1}f_{C2}}$$

$$Q = \frac{f_0}{BW}$$

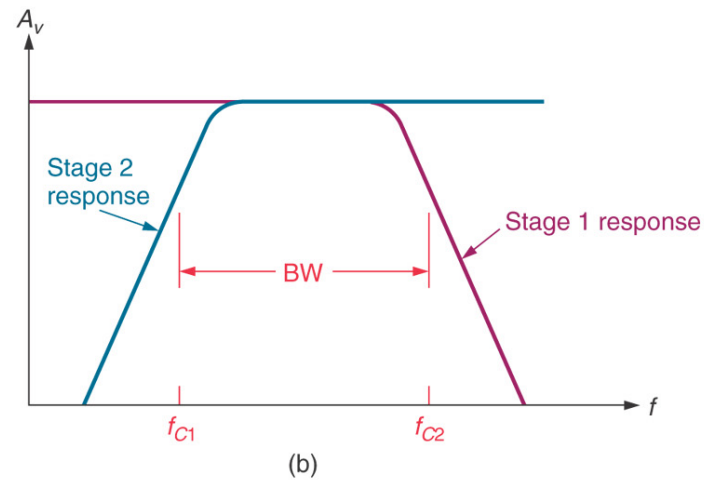

Frekvensfilter

Multiple- Feedback Båndpassfilter

Multiple- Feedback Båndpassfilter

- 2 feedback- nettverk, - et kapasitivt og et resistivt nettverk
- Krever færre komponenter enn et 2-trinns filter

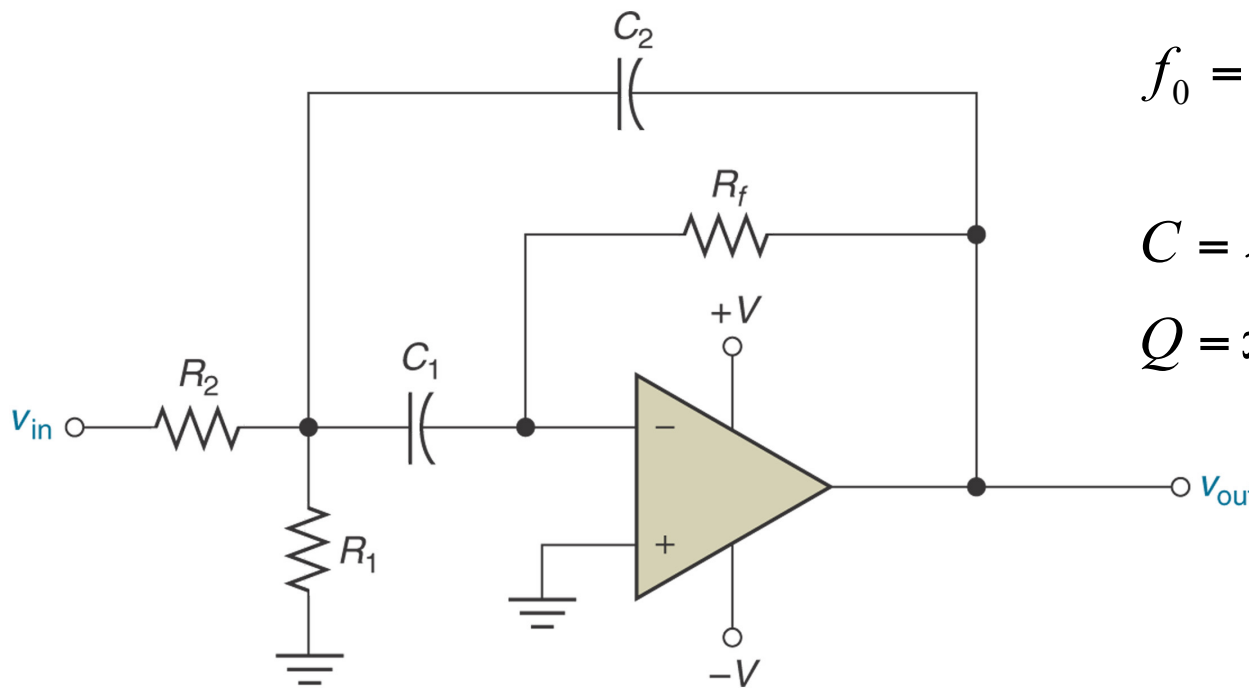

$$f_0 = \frac{1}{2\pi \sqrt{(R_1 \parallel R_2) R_f C_1 C_2}}$$

$$C = \sqrt{C_1 C_2}$$

$$Q = \pi f_0 R_f C$$

$$A_{CL} = \frac{R_f}{2R_{in}}$$

R_{in} = kretsens serie inngangsmotstand

Frekvensfilter

Notch Filter

Notch Filter – skal blokkere alle frekvenser som faller innenfor båndbredden

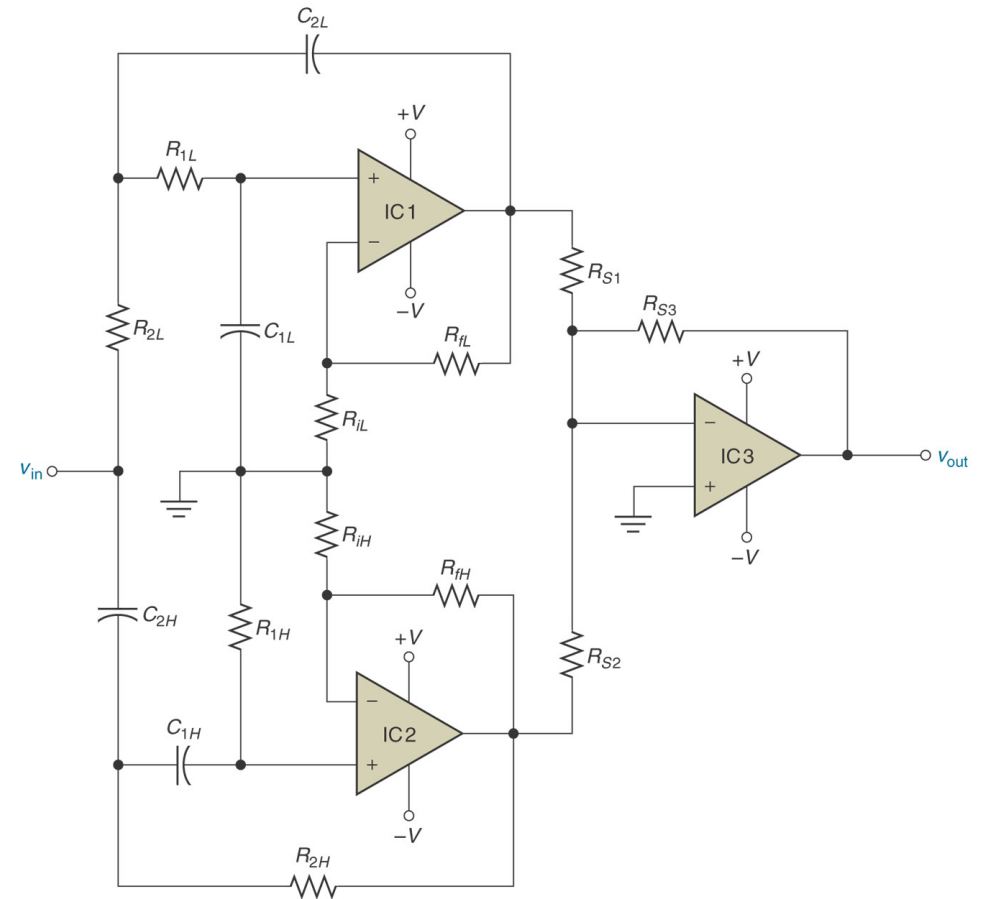
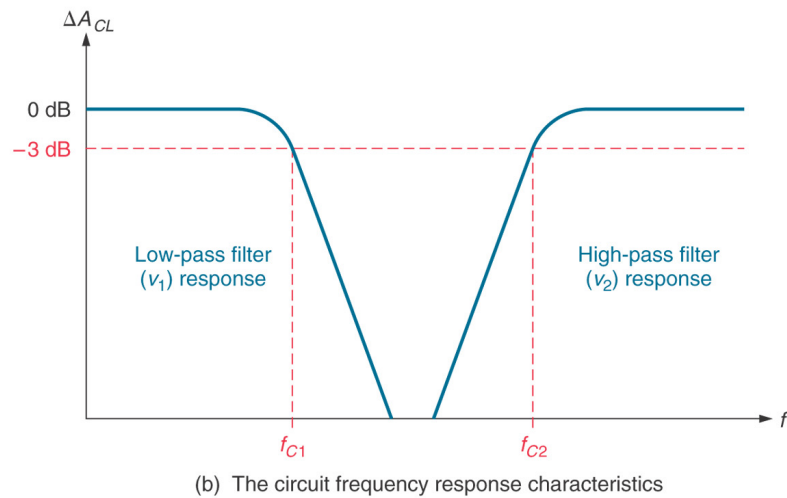
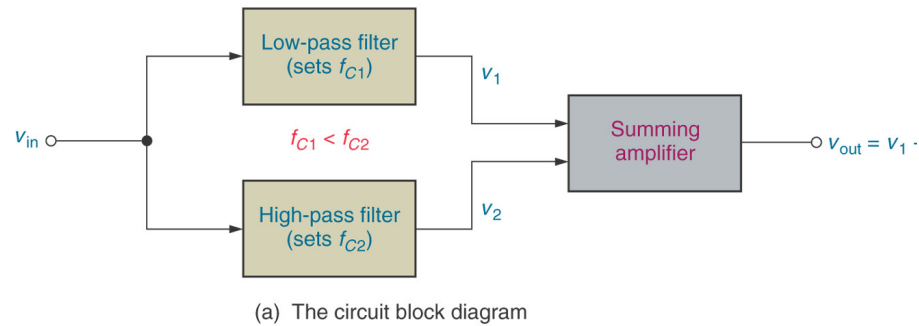

Frekvensfilter

Notch Filter

Notch Filter – skal blokkere alle frekvenser som faller innenfor båndbredden
Her realisert som et multipl feedback-filter

$$f_0 = \frac{1}{2\pi \sqrt{R_1 R_f C_1 C_2}}$$

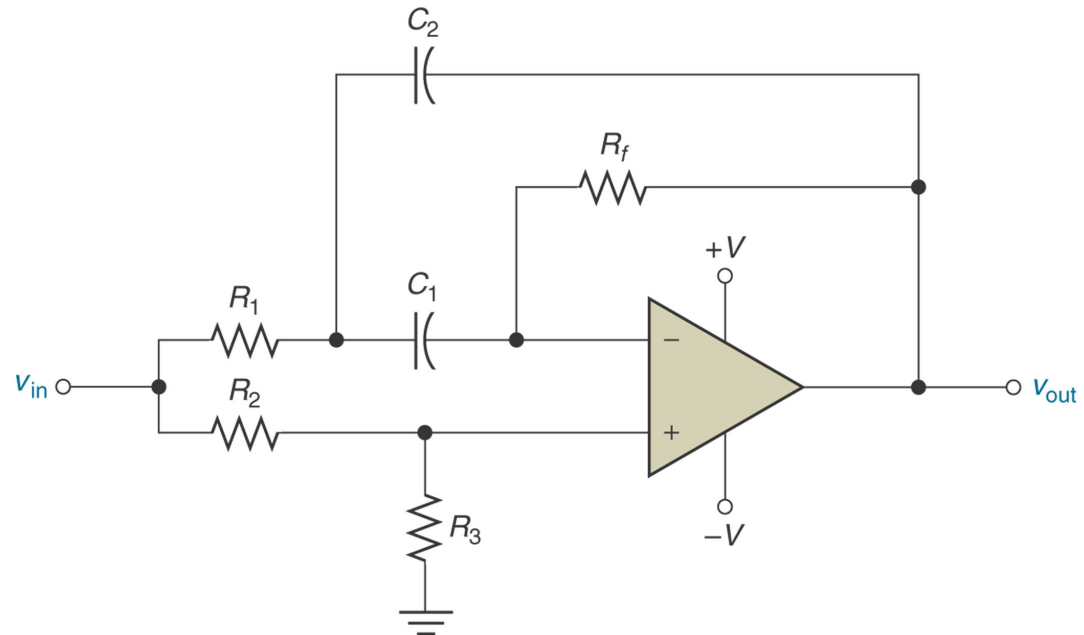
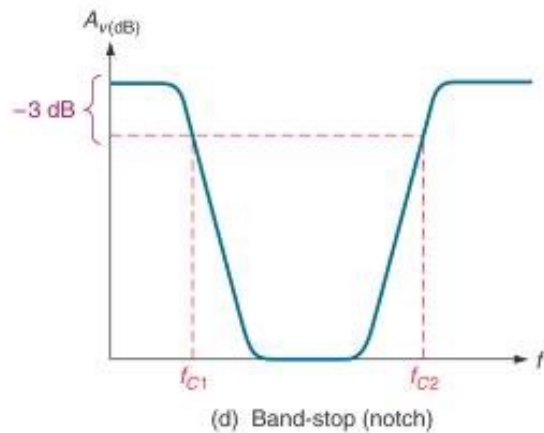

Frekvensfilter

Aktive filtre

Aktive filtre – noen anvendelser - delefilter for høyttalere

