

# Strømforskyning

Power supply

# Power supply

Lindem 2009

## Spenningsregulator- kap 25

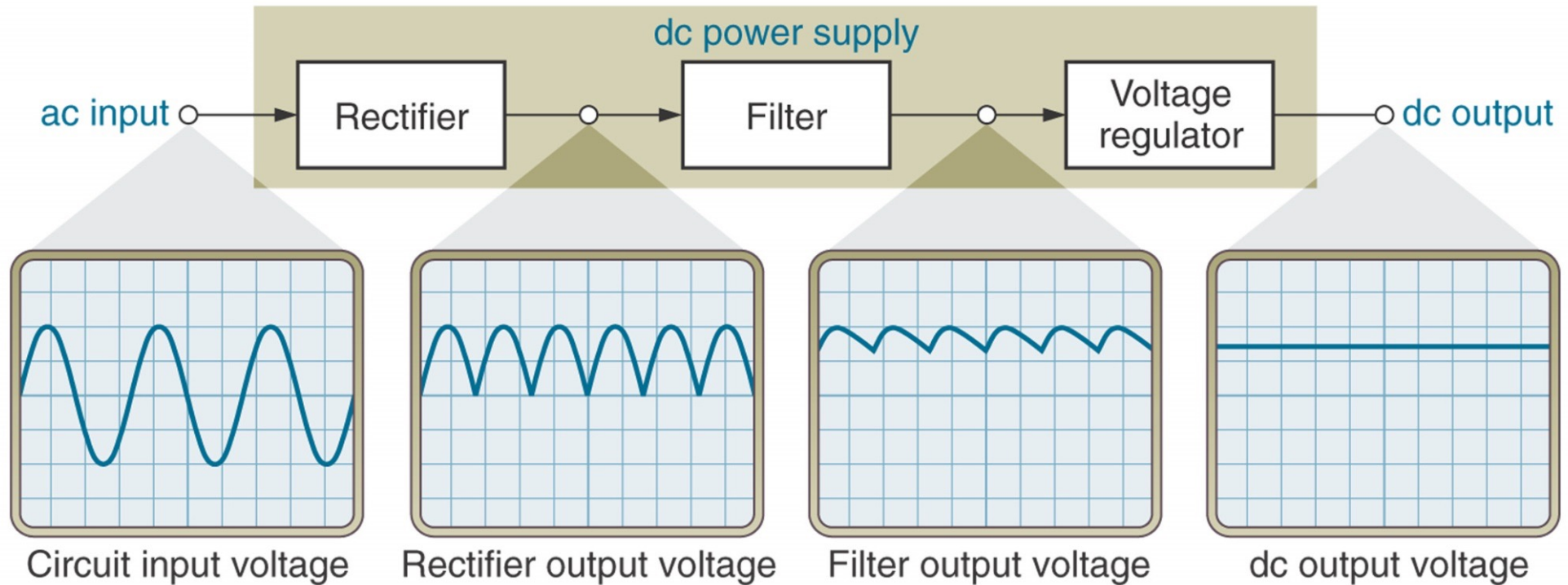

# Power supply

- Spenningsregulator

En ideell spenningsregulator

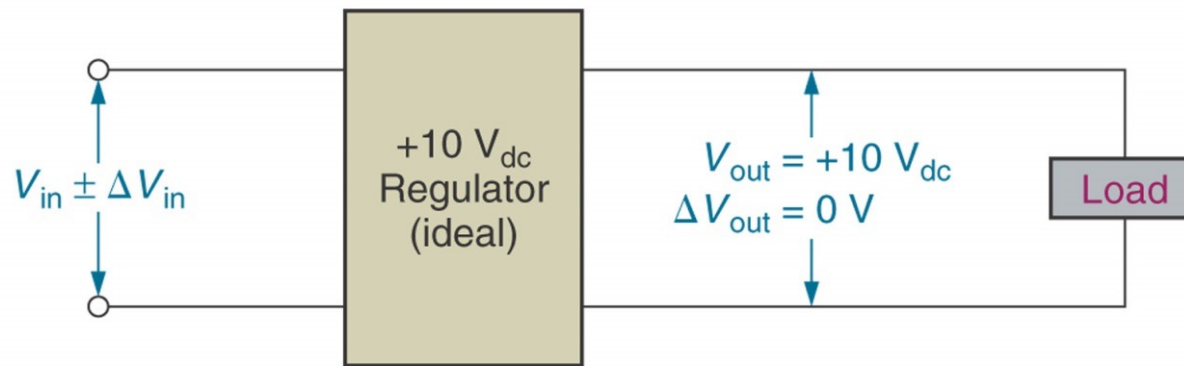

(a)

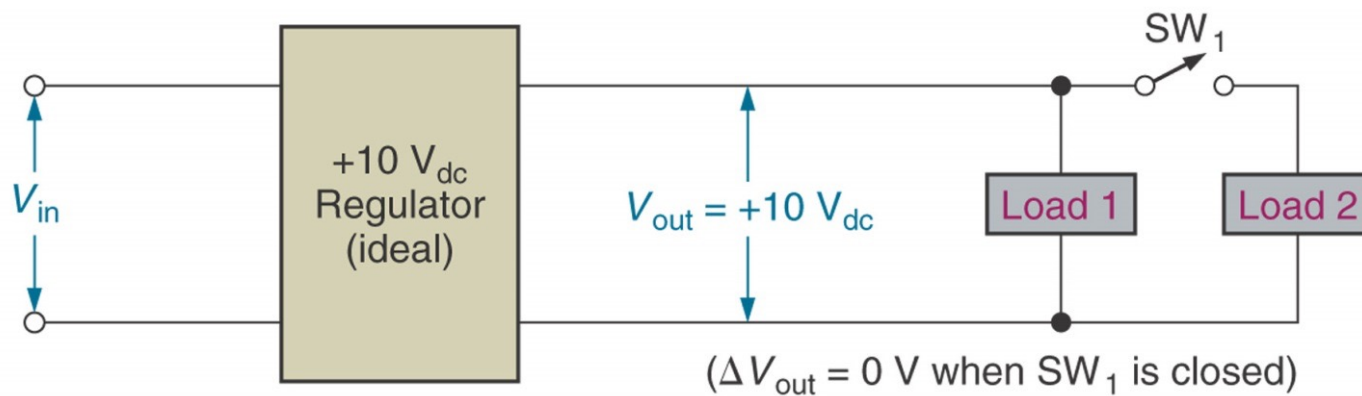

(b)

# Power supply

- Spenningsregulator

$$\text{line regulation} = \frac{\Delta V_{\text{out}}}{\Delta V_{\text{in}}}$$

$\Delta V_{\text{out}}$  = the change in output voltage  
(usually in microvolts or millivolts)  
 $\Delta V_{\text{in}}$  = the change in input voltage  
(usually in volts)

$$\text{load regulation} = \frac{V_{NL} - V_{FL}}{\Delta I_L} = \frac{\Delta V_{\text{out}}}{\Delta I_L}$$

$\Delta V_{NL}$  = the no-load output voltage (i.e., the output voltage when the load is open)

$\Delta V_{FL}$  = the full-load output voltage (i.e., the load current demand is at its maximum value)

$\Delta I_L$  = the change in load current demand

# Power supply

- Spenningsregulator

- Types of Regulators
  - Series Regulator
  - Shunt Regulator

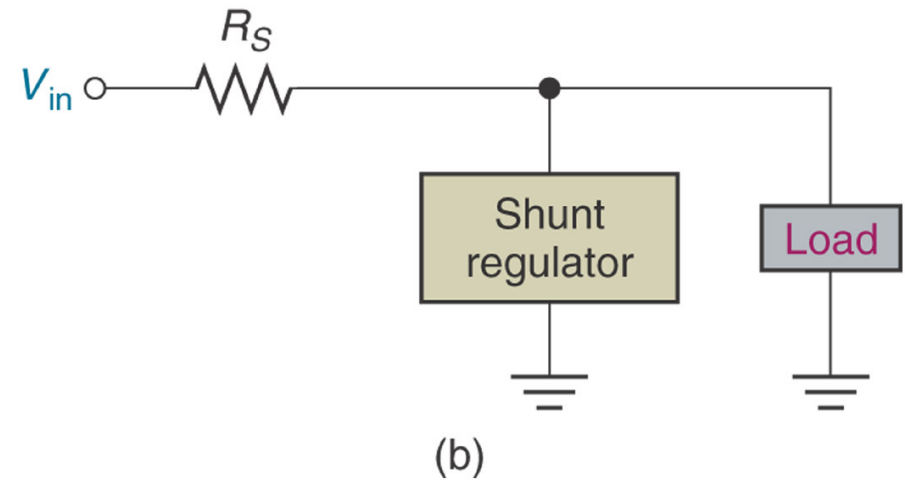
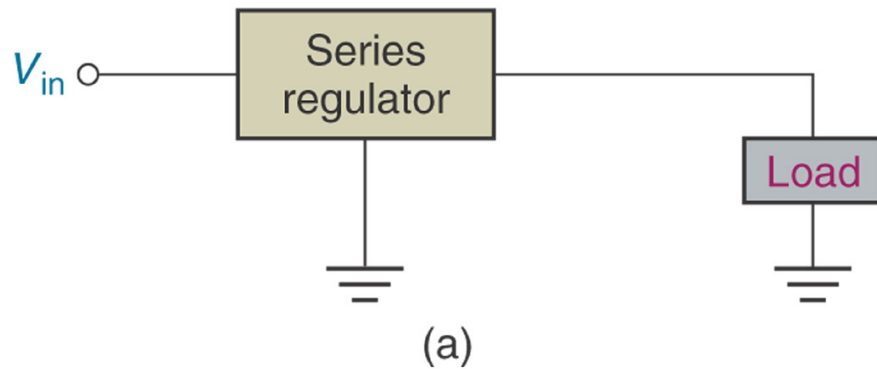

# Power supply

## - Spenningsregulator

Series Regulators – circuits that have one or more devices placed in series with the load

Pass-Transistor Regulator – a circuit that uses a series transistor to regulate load voltage

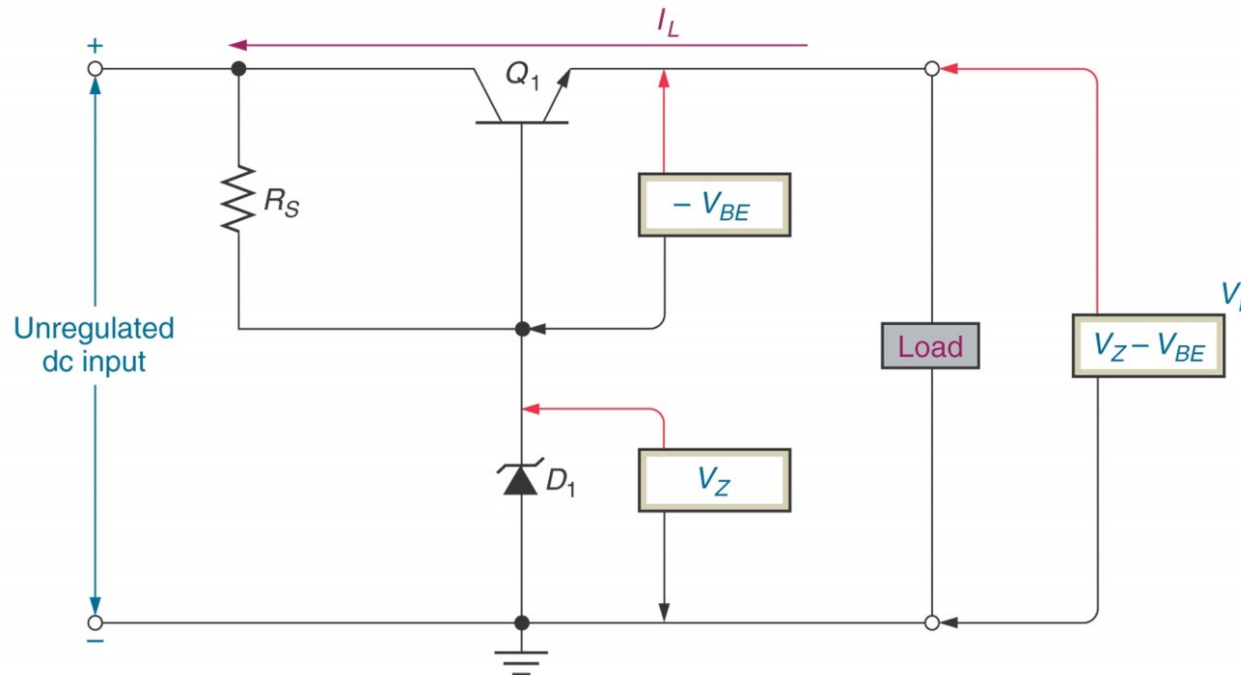

A decrease in  $V_L$  causes  $V_{BE}$  to increase, which increases conduction through the pass transistor and a relatively constant load voltage is maintained

# Power supply

## - Spenningsregulator

Problem: As input voltage or load current increases, the zener diode must dissipate a relatively high amount of power – reduced by using a Darlington pass-transistor regulator

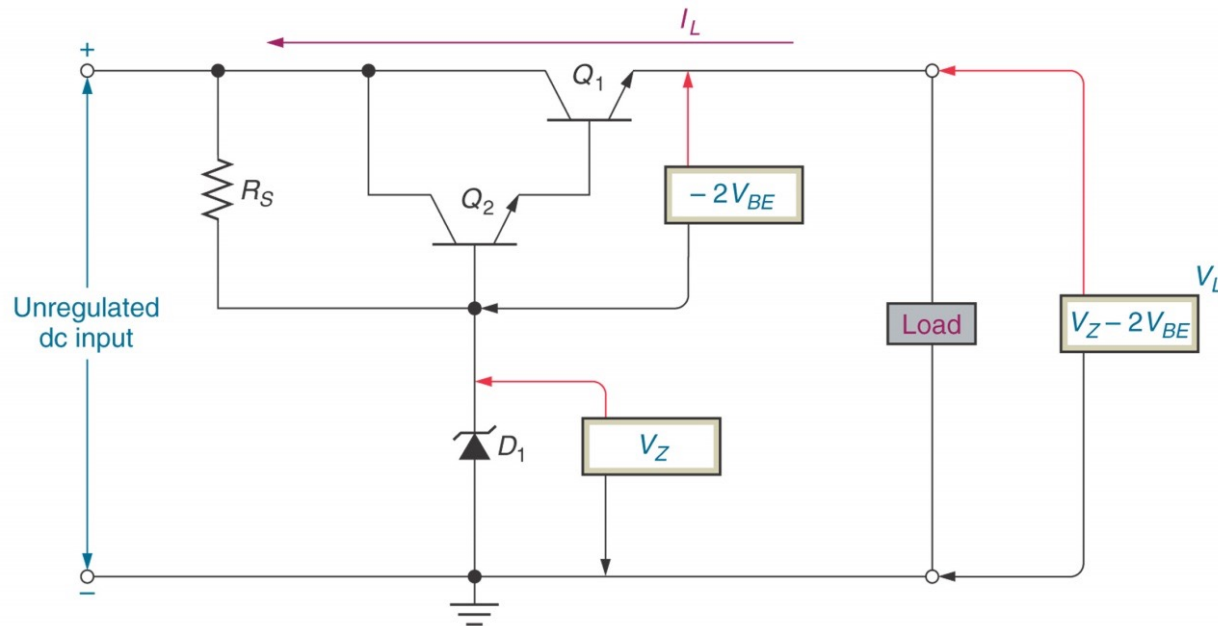

$$V_L = V_Z - 2V_{BE}$$

# Power supply

## - Series Feedback Regulator

A series regulator that uses an error detection circuit to provide improved line and load regulation characteristics

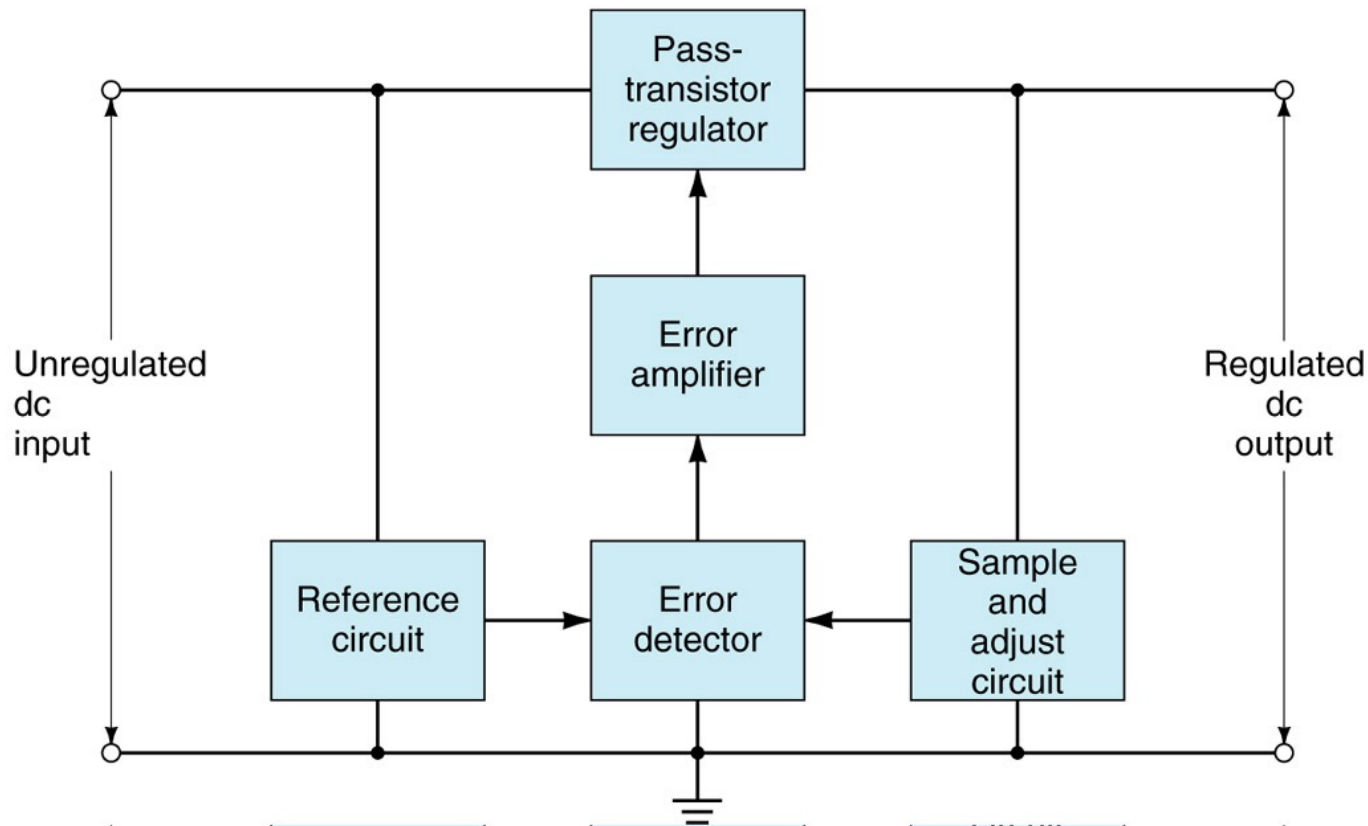



# Power supply

## - Series Feedback Regulator

Series Feedback Regulator – a series regulator that uses an error detection circuit to provide improved line and load regulation characteristics

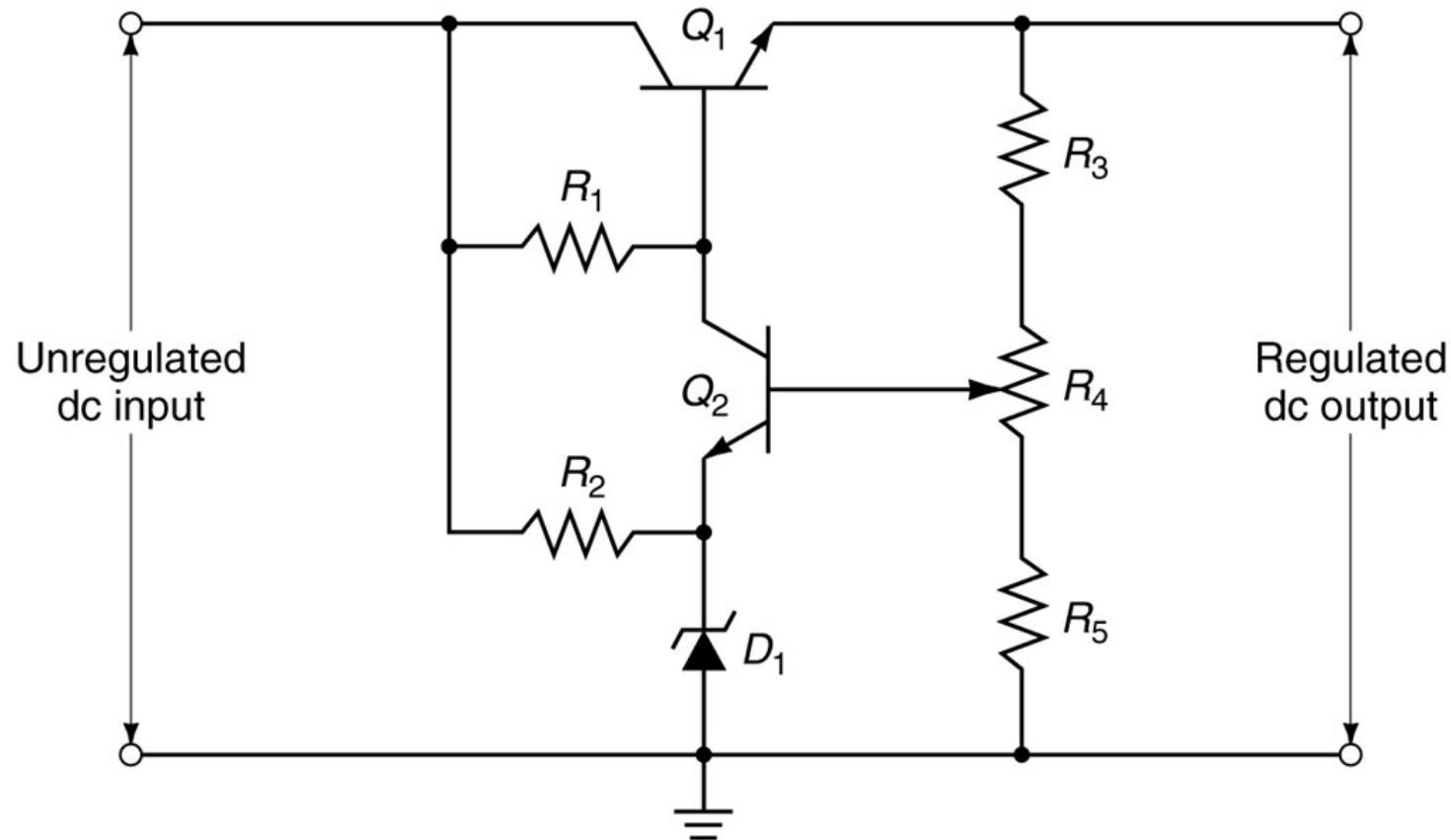

# Power supply

- Spenningsregulator m / sikring

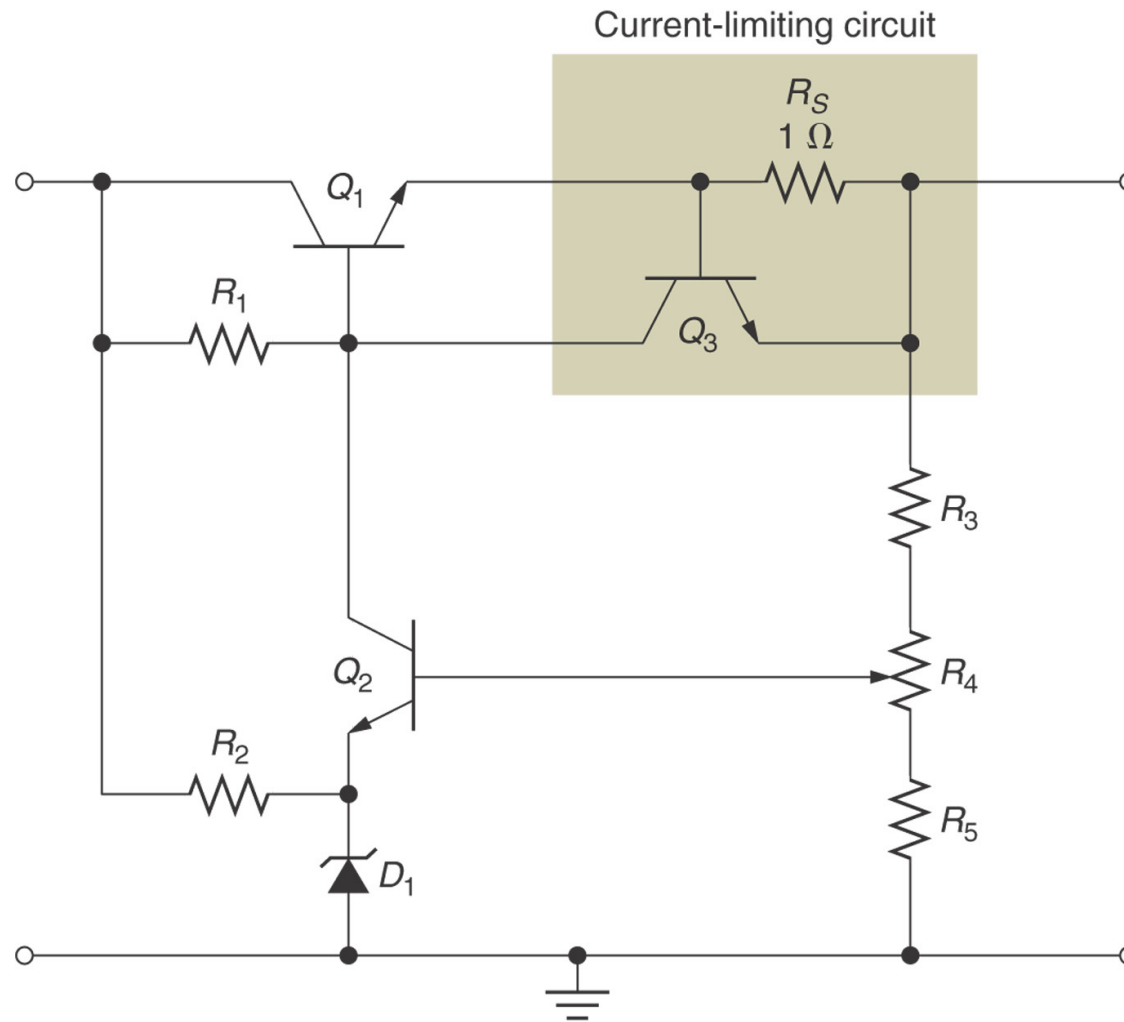

$$I_{E(\max)} \cong \frac{V_{BE(Q3)}}{R_S}$$

# Power supply

## Shunt Feedback Regulator

Shunt Regulator – a circuit that has a regulating transistor in parallel with the load

Shunt Feedback Regulator – a circuit that uses an error detection circuit to control the conduction through a shunt regulator transistor

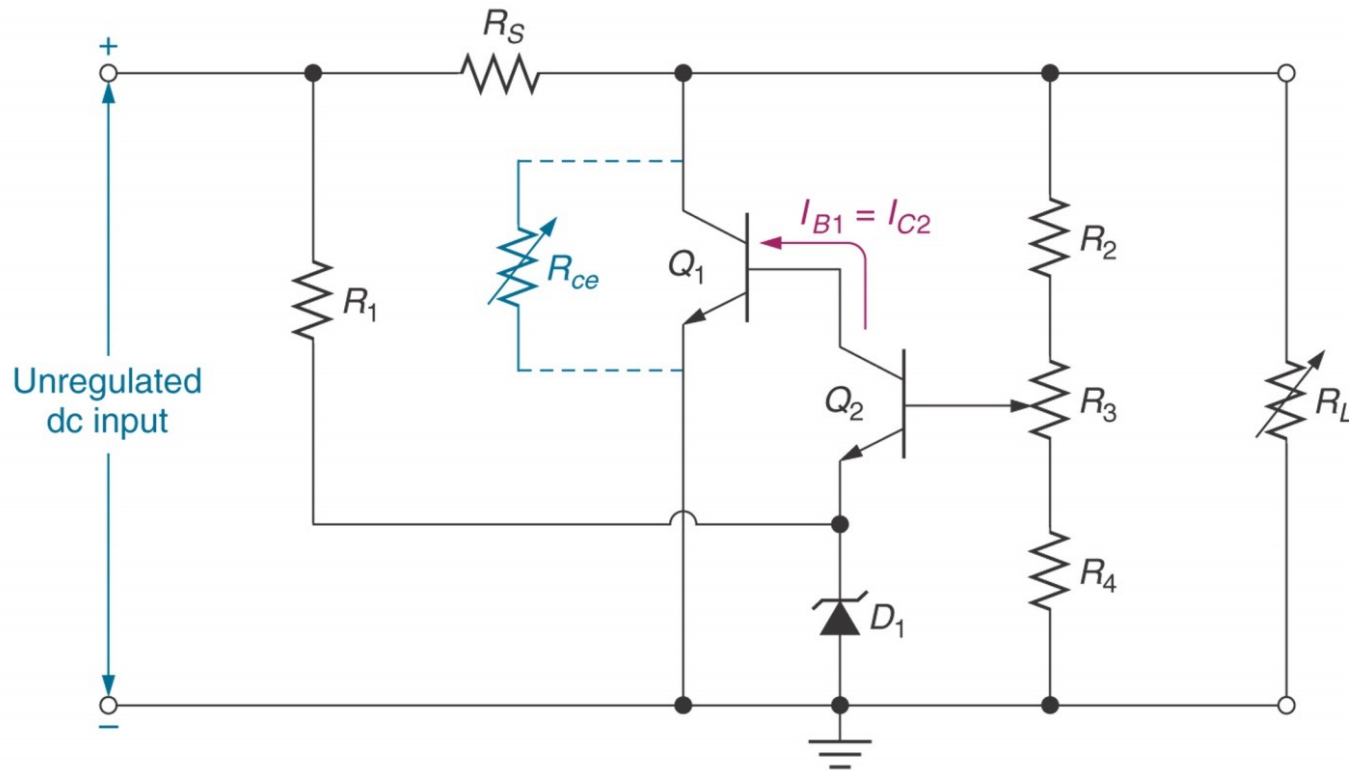

# Power supply

## Linear IC Voltage Regulators

- a device that is used to hold the output voltage from a dc power supply relatively constant over a specified range of line and load variations

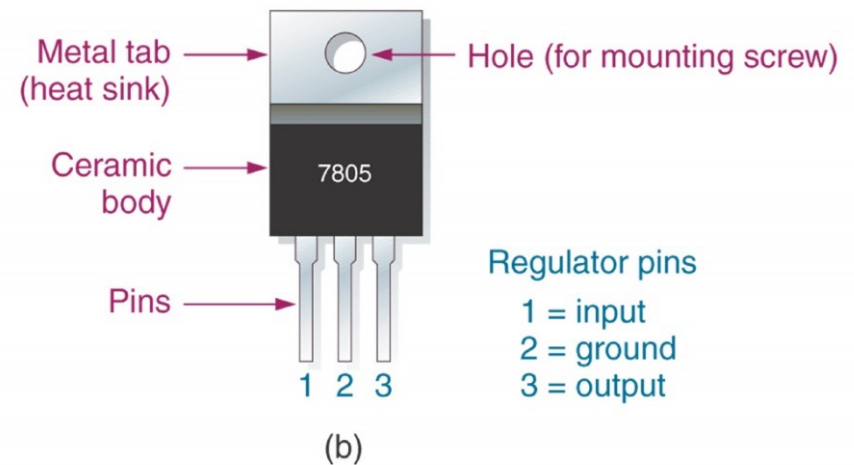
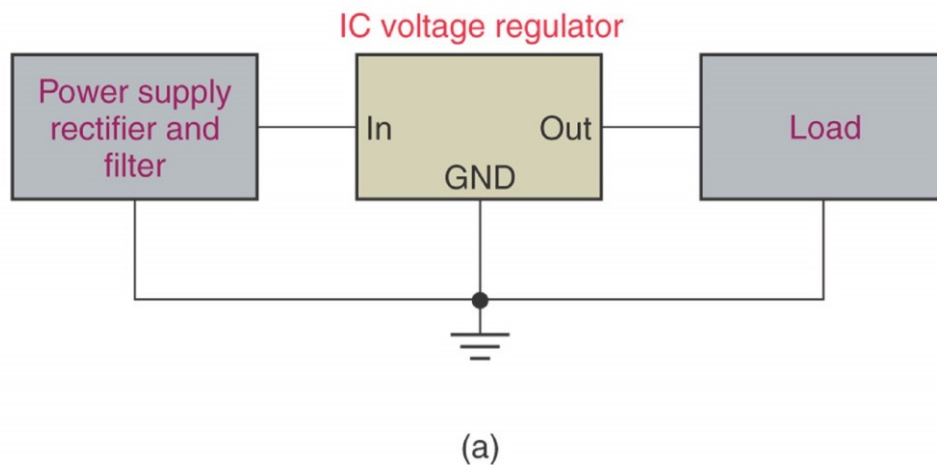

### Basically Four Types

Fixed-Positive – provide a specific positive voltage

Fixed-Negative – provide a specific negative voltage

Adjustable – can be adjusted within a specified range of values

Dual-Tracking – provides equal positive and negative output voltages

# Power supply

## Linear IC Voltage Regulators

Adjustable Regulators – Example LM317

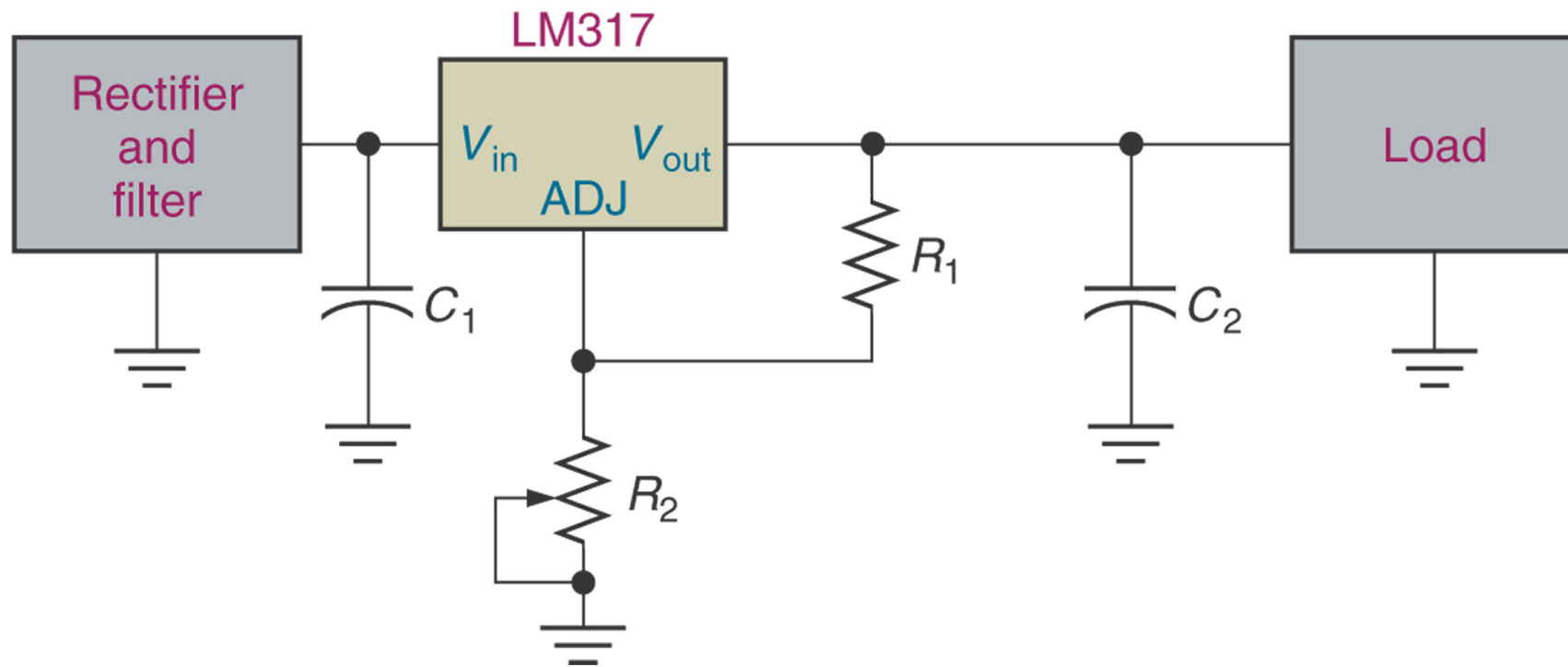

# Power supply

## Switching Regulators

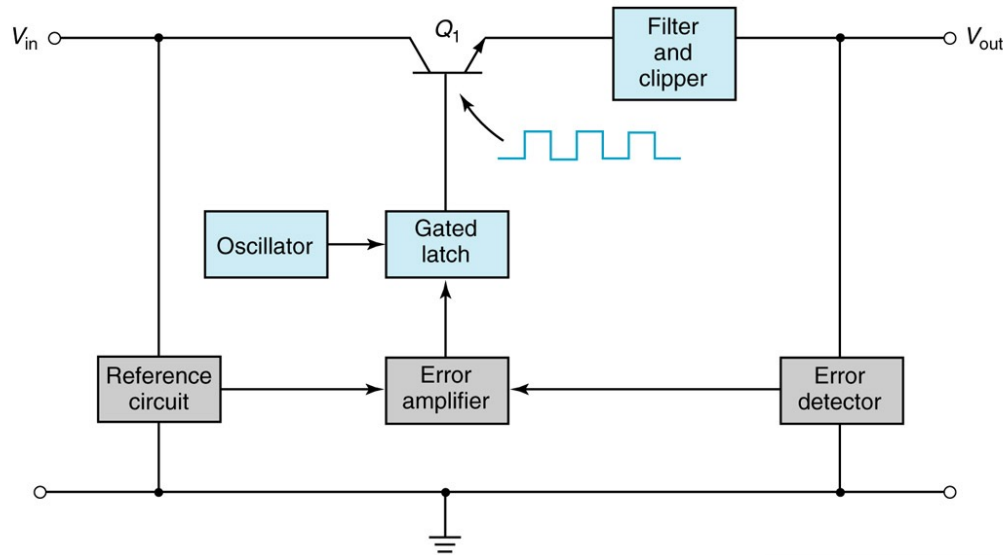

- Switching Regulator Operation – when the control circuit senses a change in the output voltage, it sends a signal to the switch driver

The power switch is constantly driven back and forth between saturation and cutoff  
Average voltage at the emitter of the power switch

$$V_{\text{ave}} = V_{\text{in}} \left( \frac{T_{\text{on}}}{T_{\text{on}} + T_{\text{off}}} \right)$$

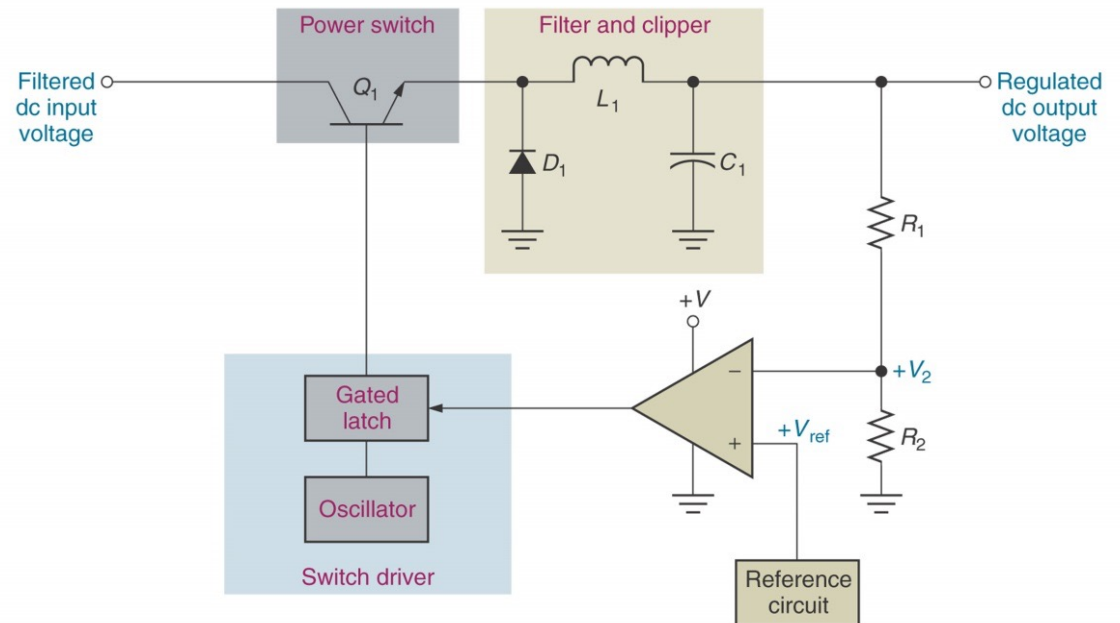

Radio

# Hva er radio

Radio er en teknologi som tillater sending av signaler ved å modulere elektromagnetiske bølger. Bølgene trenger ikke et medium å forplante seg i, men brer seg godt gjennom både luft og vakuum.

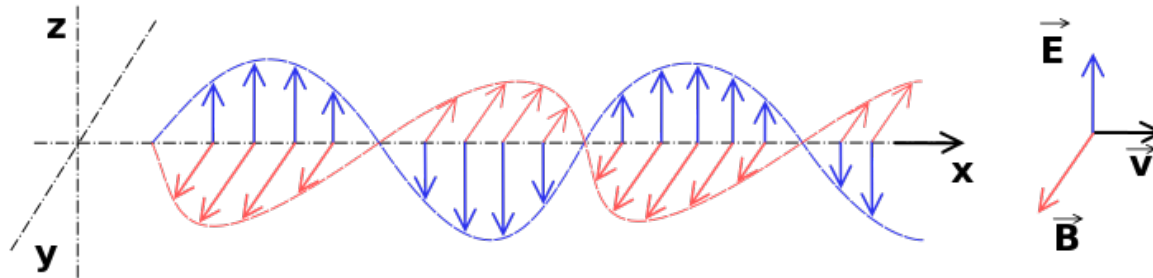

I det elektromagnetiske spektret ligger frekvensen til signaler brukt til kommunikasjon i den nedre delen og under frekvensen for synlig lys

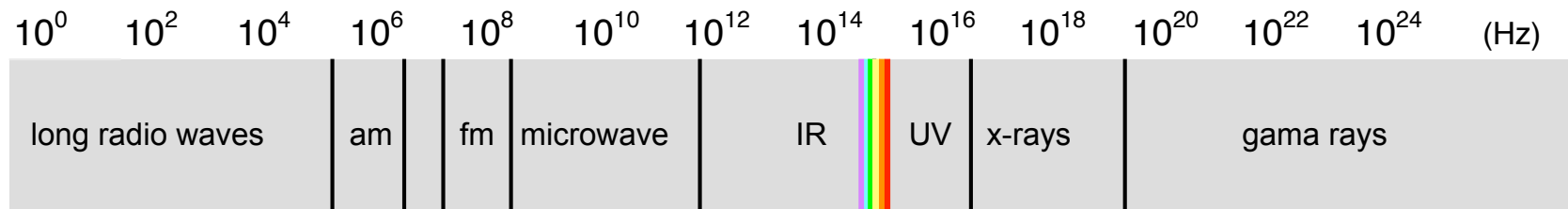



# Modulasjon

Informasjon som skal overføres gjennom radio signaler benytter ulike modulasjon metoder for å sende informasjonen. Vi skal se på tre typer: amplitude modulasjon, frekvens modulasjon, fase modulasjon

Informasjon signal

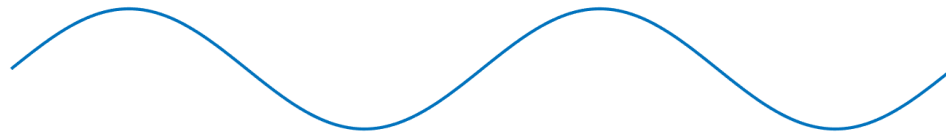

Amplitude modulasjon

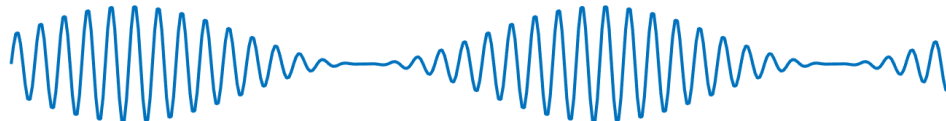

Frekvens modulasjon

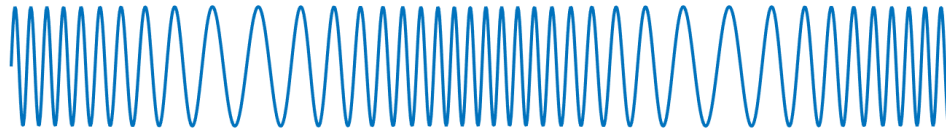

Fase modulasjon

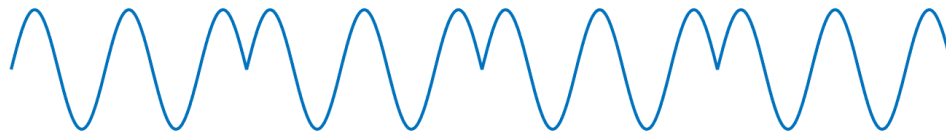

# Amplitude modulasjon AM

Informasjonen i signalet som vi ønsker å sende modulerer amplituden (signalstyrken) på bæreboegen. Langbølge, mellombølge og kortbølge radio benytter alle amplitude modulasjon.

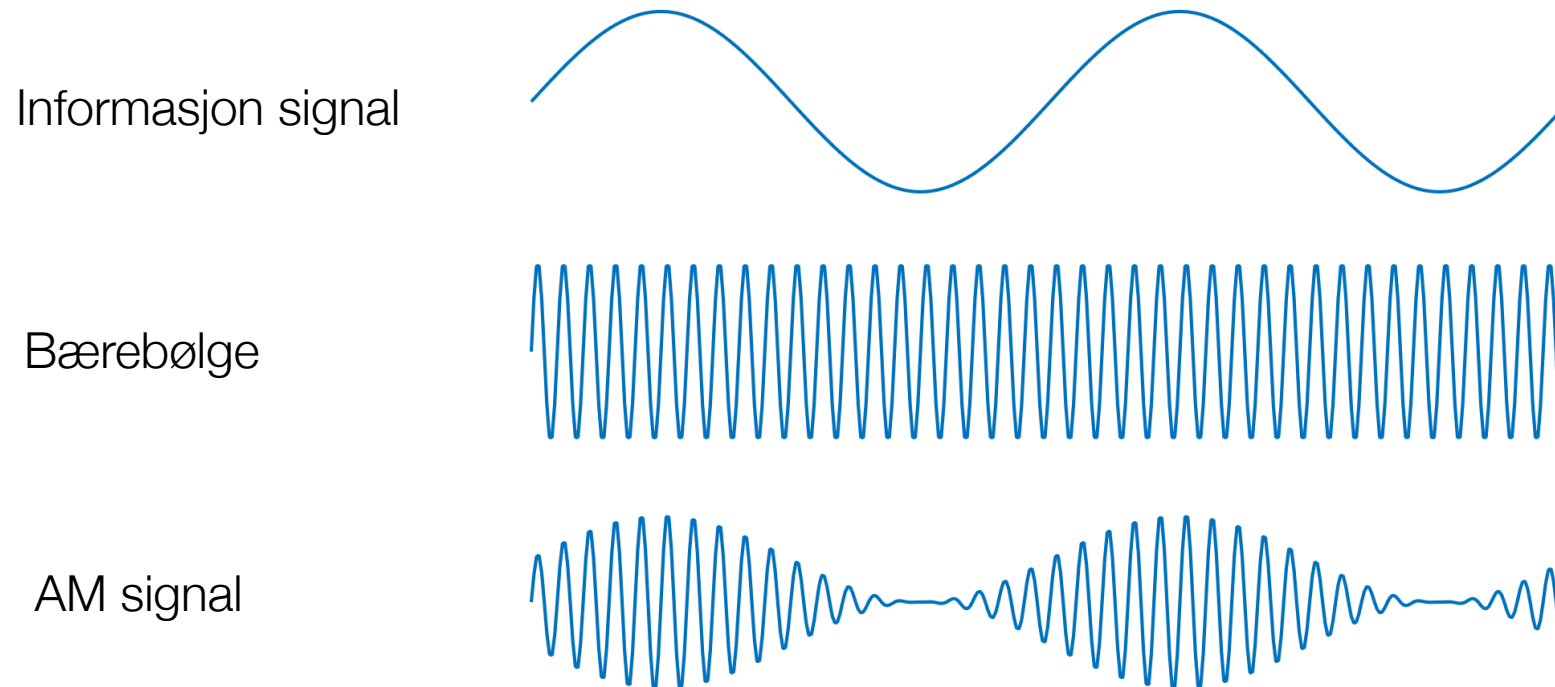

Modulasjonsfrekvensen bestemmer båndbredden til radiostasjonen og er regulert gjennom en internasjonal avtale fra 1923:

- Frekvensseparasjon på 10kHz mellom stasjonene.
- Lydinholdet må ikke inneholder frekvenser over 4.5 kHz

# Amplitude modulasjon AM

Alle frekvenser legges forsterket inn til en "mixer". Ut fra mikseren får vi sum og differanse av de to frekvensene (foruten de to grunnfrekvensene)  
Den antennefrekvensen som ligger 455 kHz unna lokaloscillatorfrekvensen blir forsterket.

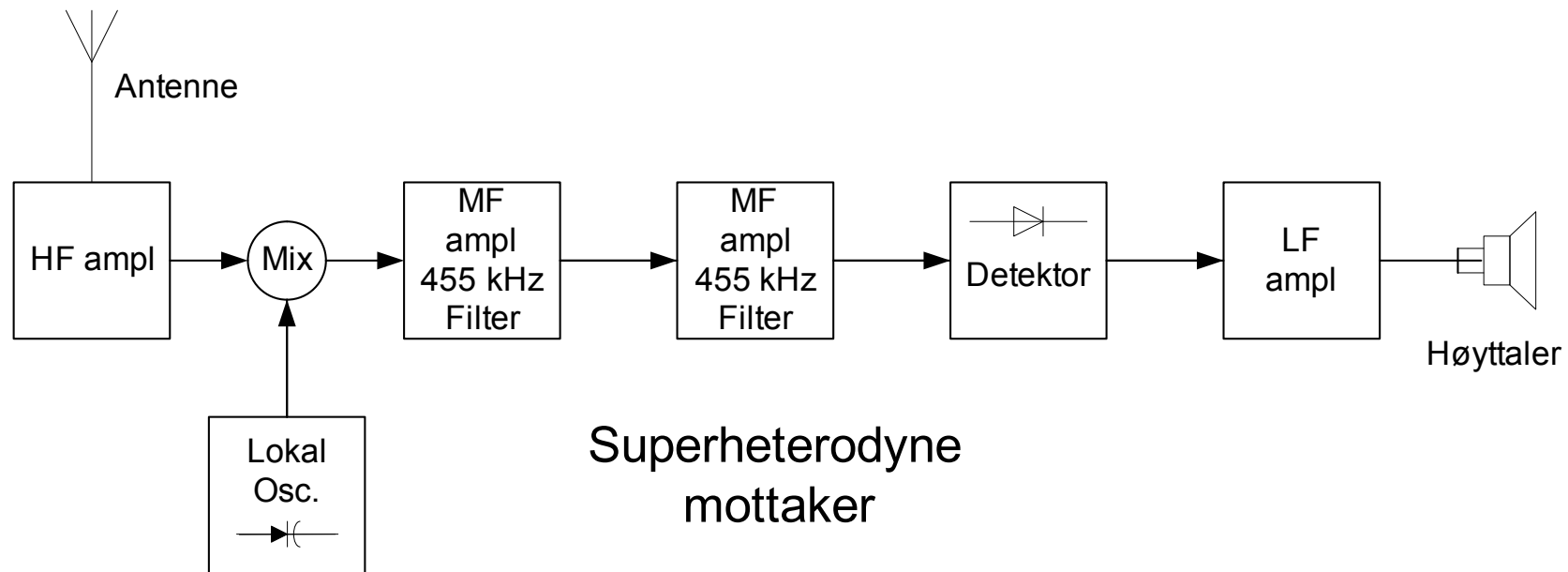

Mellomfrekvens (MF) AM = 450 - 470 kHz (455 kHz mest brukt)  
Enkelte kortbølgemottakere kan ha 2 mellomfrekvenser. (Dobbelt super)  
Første MF pleier å være 3,5 MHz – deretter mikses ned til 455 kHz.

# Frekvens modulasjon FM

Informasjonen i signalet som vi ønsker å sende modulerer frekvensen på bærebøgen. Forskjellen mellom frekvensen i den modulerte bærebølgen og bærebølgen sin senterfrekvens er proporsjonal med informasjons signalet

Informasjon signal

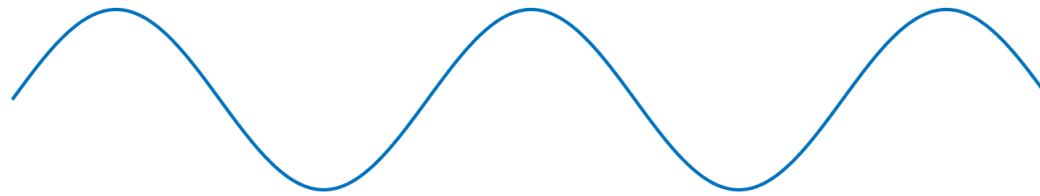

Bærebølge signal

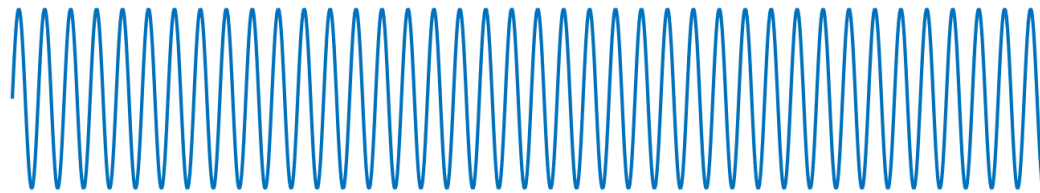

FM signal

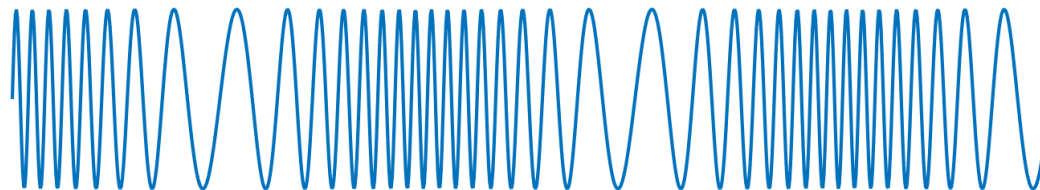

FM-stereo sender må sende et signal som også kan mottas av en gammel radio uten stereo dekker (mono) for å få til dette benyttes Time Division Multiplexing (TDM) – tidsmultipleksing. Senderen veksler mellom to kanaler med en frekvens på 38 kHz, ca. 26 us på hver kanal, noe som er tilstrekkelig til å reprodusere 15 kHz på begge kanaler. Den ene kanalen inneholder mono signalet L+R den andre kanalen inneholder L-R. Stereo signalet hentes ut ved å legge sammen/trekke fra de respektive kanalene  $(L+R)+(L-R) = 2L$  og  $(L+R)-(L-R) = 2R$

# Frekvens modulasjon FM

FM - 87.5 -108.0 MHz Vest-Europa 100 kHz alt. 200kHz mellom stasjonene  
65 - 74 MHz tidliger østblokken 30 kHz mellom stasjonene  
76 - 90 MHz Japan (90 -180 MHz brukt av analog VHF TV)

Mellomfrekvens for FM-radio 10,7 MHz

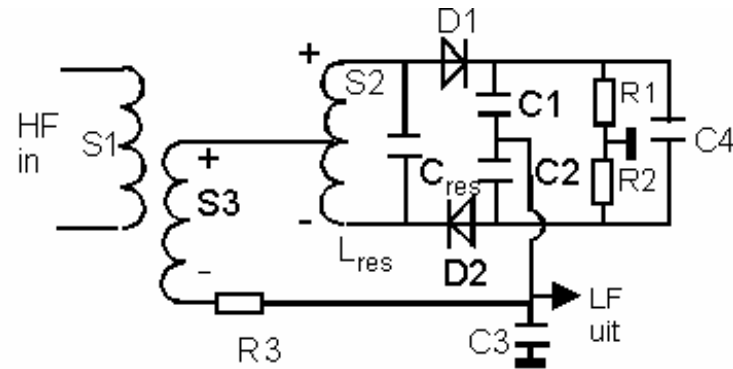

Kvadraturdetektor FM to LF-AM

# Faseskift modulasjon

## Phase Shift Keying (PSK)

Informasjonen i signalet som vi ønsker å sende modulerer fasen på bæreboen ved å legge inn et faseskift. Blir brukt i forbindelse med wireless LANs, RFID og Bluetooth og finnes i ulike varianter.

Information signal

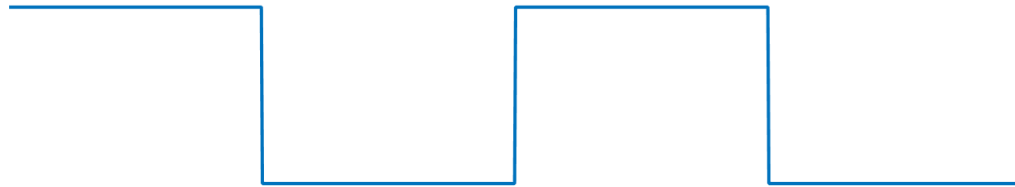

Carrier signal

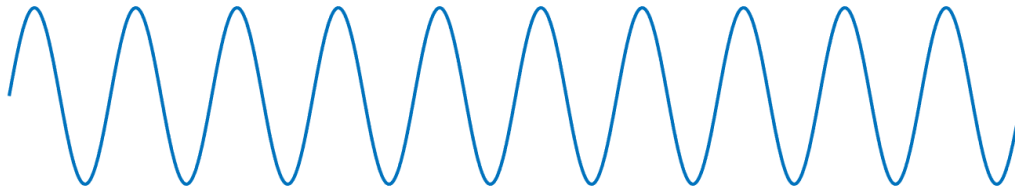

PSK signal

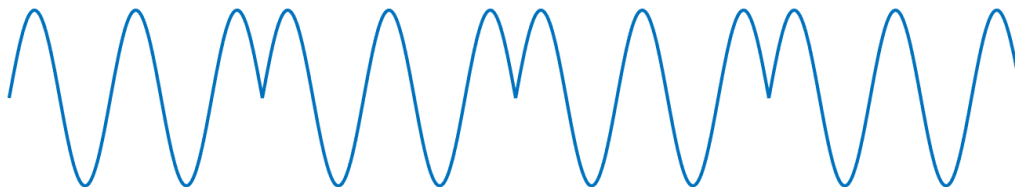

# Radio forstyrrelser

Refleksjon og absorpsjon av radiobølger i ionosfæren

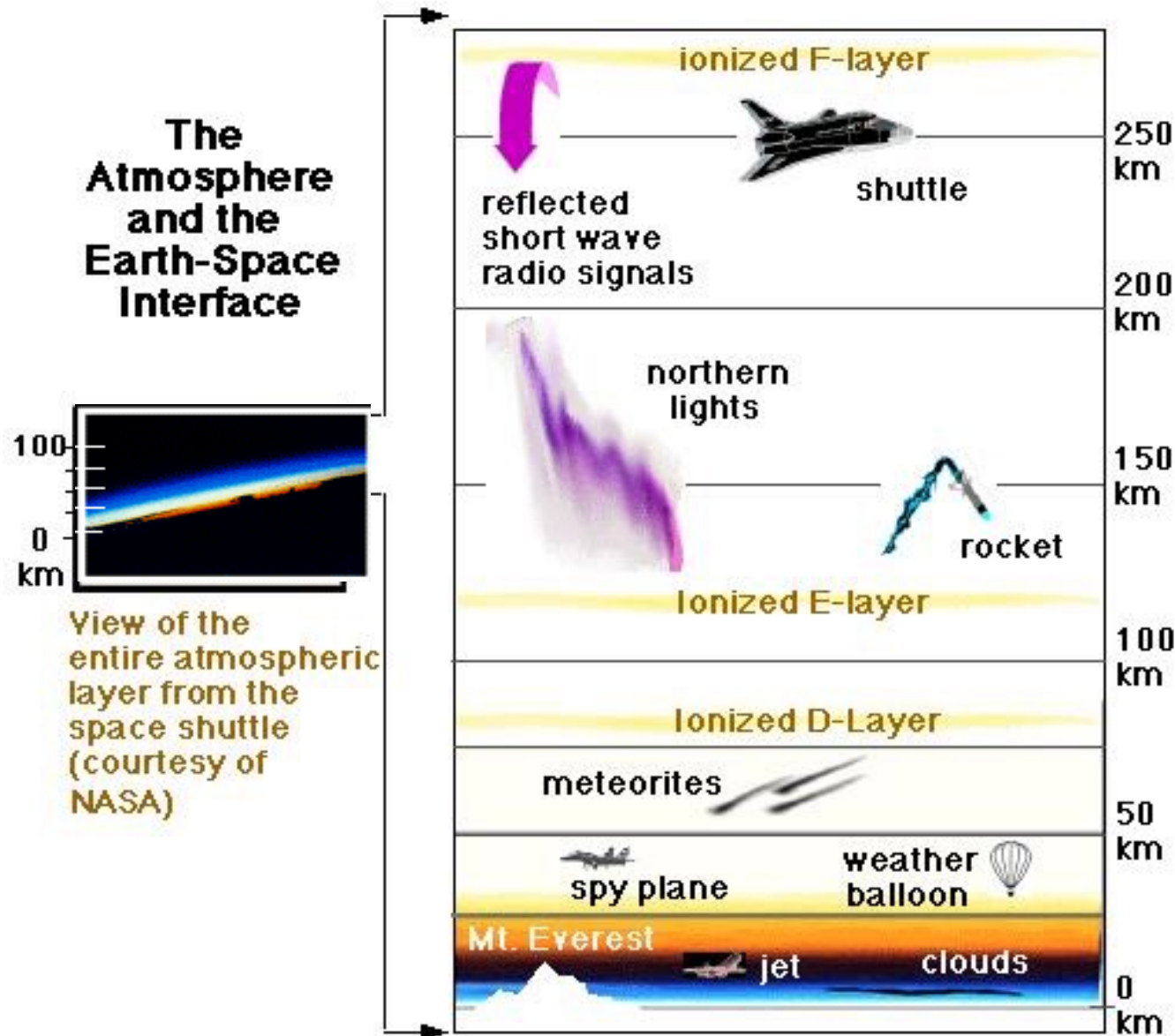

# Hva skjer i ionosfæren

Radio – Refleksjon og absorpsjon av radiobølger i ionosfæren.

Reflekterende lag i ionosfæren gir noen radiosignaler global utbredelse.

Turbulens i ionosfæren skaper problemer for bl.a. GPS-signaler og VHF kommunikasjon med fly i polare områder

Koplingen Sol – Jord er et forskningsfelt med lange tradisjoner ved Fysisk inst.

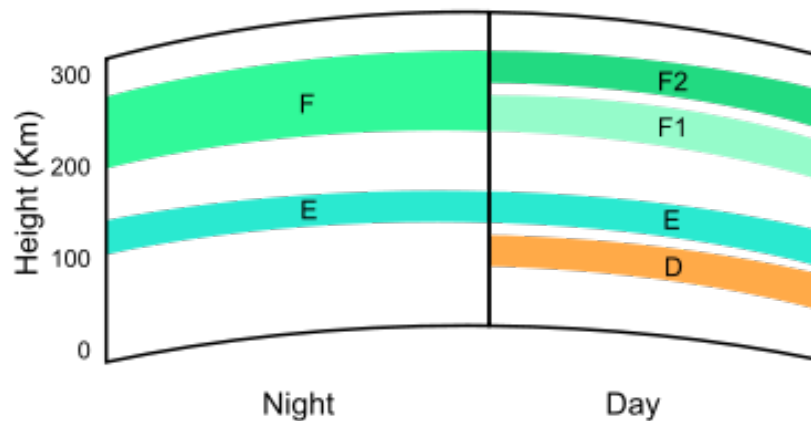

D-layer 60 – 90 km. Oppstår på dagtid. Sollyset ioniserer Nitrogenoksyd (NO) – som igjen forårsaker absorpsjon av enkelte radiofrekvenser.

Dette forklarer hvorfor noen MB stasjoner “forsvinner” på dagtid.

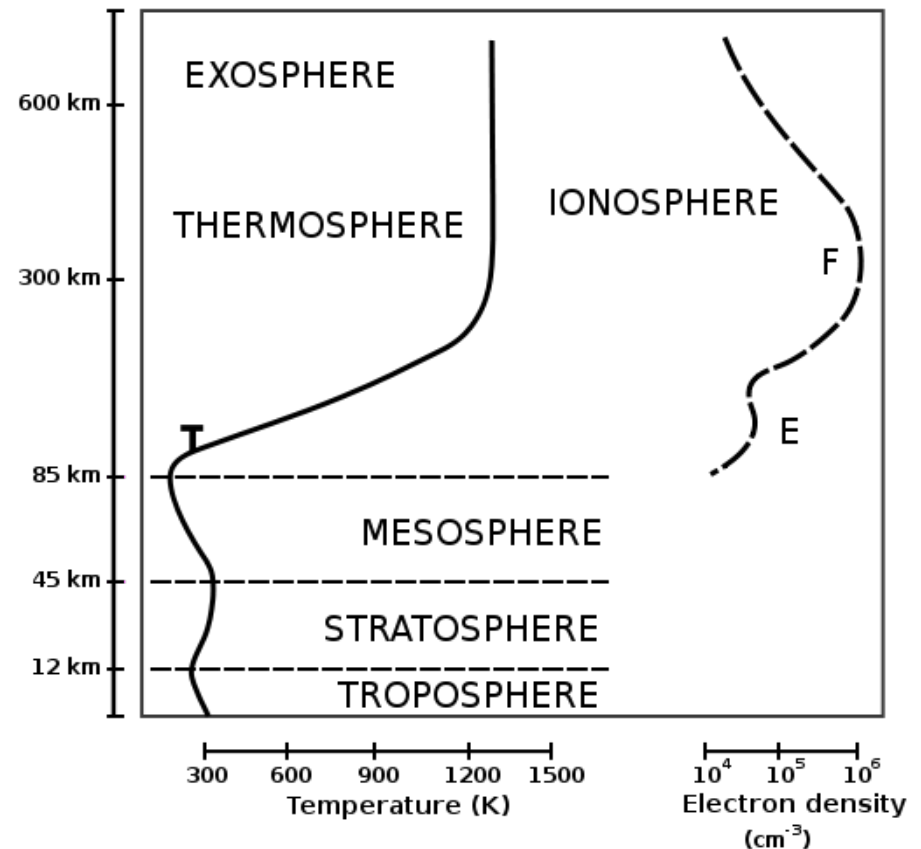



# Jordas magnetfelt

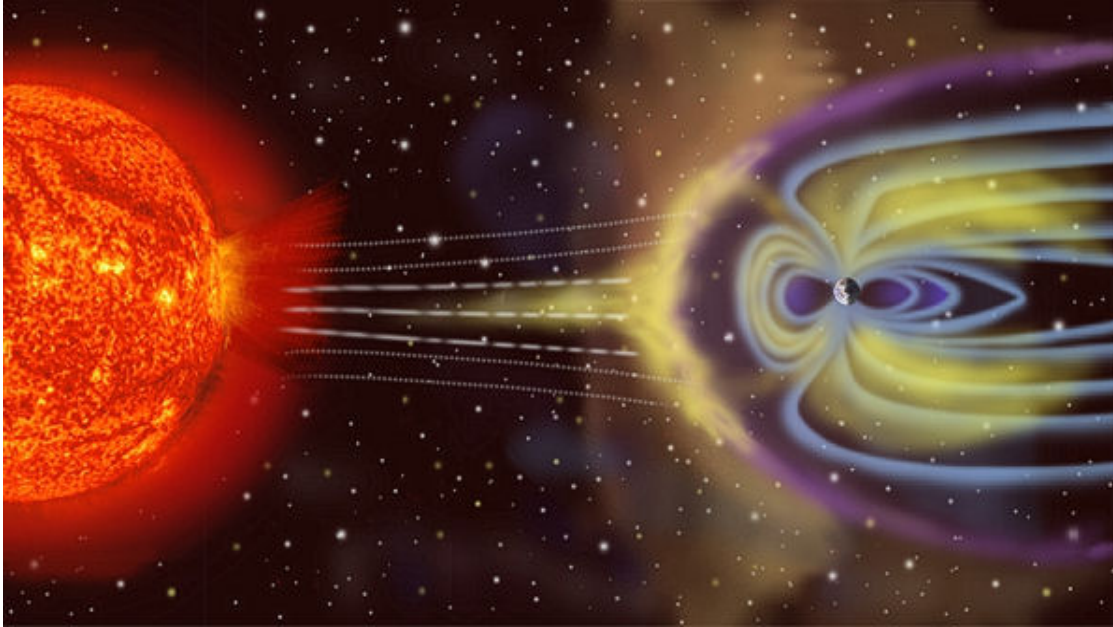

Jordas magnetfelt beskytter oss mot farlig stråling fra sola.

Men i nordlys-sonen er det en åpning hvor mange partikler kan komme inn i ionosfæren

Andøya ligger midt i nordlysbelte. Mange «tunge» vitenskaplige instrumenter er lokalisert her – sammen med Andøya rakettskytefelt.

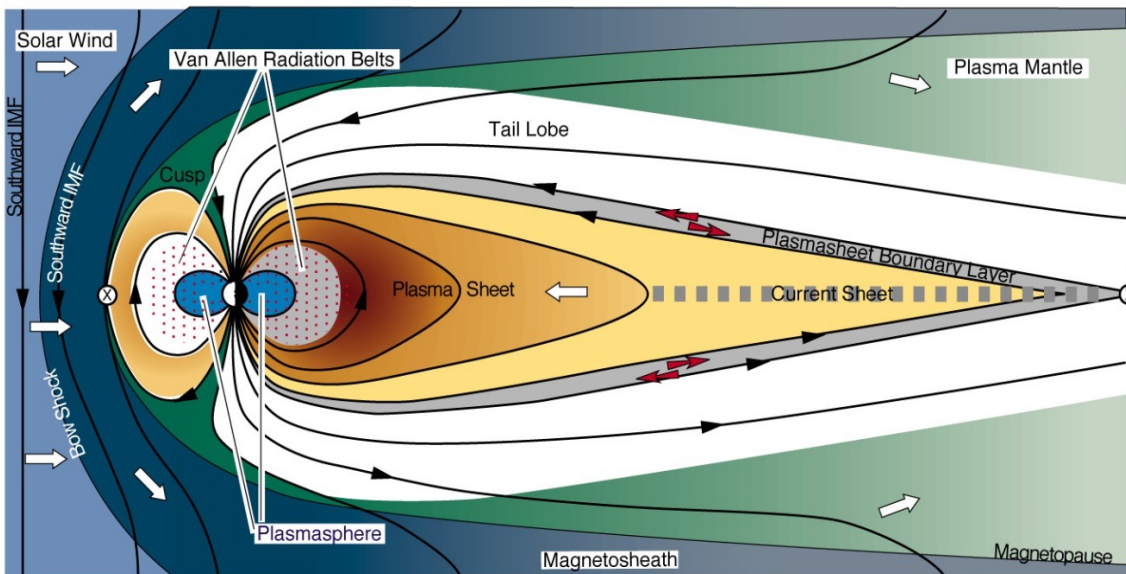

# Elektromagnetiske signaler – Mange bruksområder - ikke bare radio og TV

## SKiYMET meteor radar Andøya

### **Principle:**

Short electromagnetic pulses are circularly polarized radiated by the transmit antenna and after reflection on ionisation trails of incident meteoroids received by 5 spatially separated antennas. An interferometric analysis yields location, amplitude, and radial velocity of each ionisation trail moved by the neutral wind. The wind field in 80 - 110 km can be derived from a multitude of these individual informations.

$$\lambda = \frac{C}{f} = \frac{300 \cdot 10^6 \text{ m/s}}{32,55 \cdot 10^6 \text{ 1/s}} \approx 9,2 \text{ m}$$

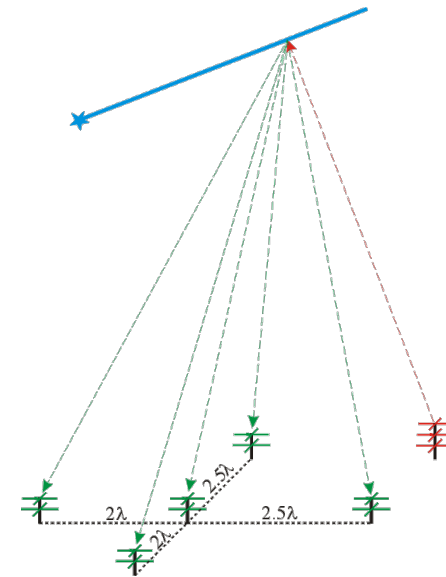

Frequency:	32.55 MHz
Power:	12 kW PEP
Pulse length	13.3 μs
Range resolution:	2 km
Transmit antenna:	1 crossed 3-element Yagi
Receive antenna:	5 crossed 2-element Yagi

# Elektromagnetiske signaler – Mange bruksområder - ikke bare radio og TV

## SKIYMET meteor radar Andøya

### **Observation data:**

- Individual meteor echos (time, location, echo amplitude, radial velocity)
- Wind field (80 - 110 km)
  - one hourly means
  - prevailing wind, 12h- and 24h-tide
- Temperature in 90 km (from ambipolar diffusion coefficient)
- Information on incident meteoroids (velocity of incidence, radiant)

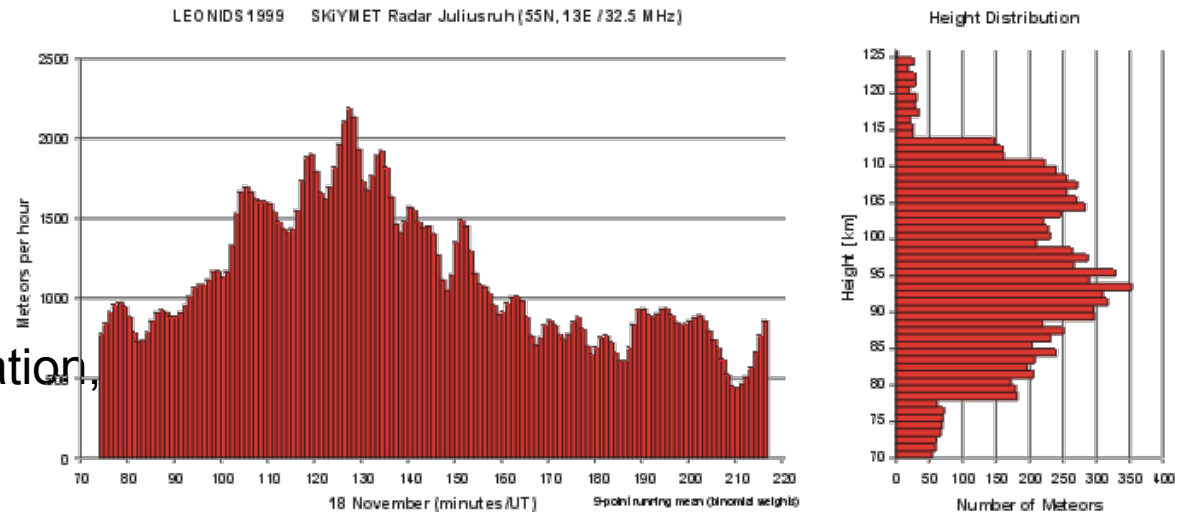

Time Variation of the amount observed meteor echos during the storm phase of the LEONIDS on the 18. November 1999 (left) and their height distribution (right).

# Elektromagnetiske signaler – Mange bruksområder - ikke bare radio og TV

## SKiYMET meteor radar Andøya

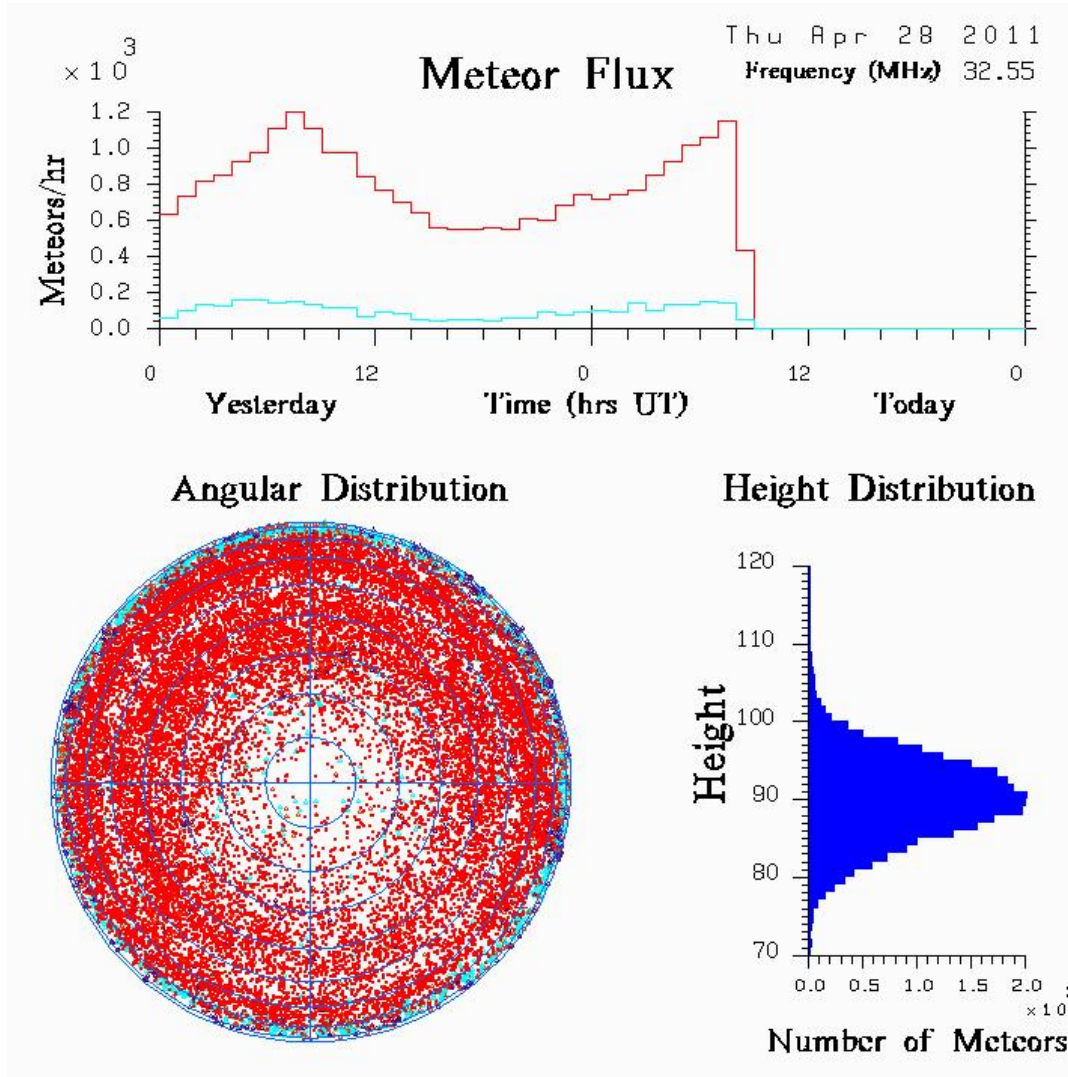

# Elektromagnetiske signaler – Mange bruksområder - ikke bare radio og TV

## The VHF ALOMAR wind radar - ALWIN

On October 12th, 1998 a new VHF radar for investigation of the dynamics and structure of the lower and middle atmosphere in polar regions - Andenes/Norway (69.17°N; 16.01°E) - was put into operation. The radar system is designed for unattended, continuous operation and is capable to operate either in the Spaced Antenna (SA) or in the Doppler Beam Swinging (DBS) mode



# Elektromagnetiske signaler – Mange bruksområder - ikke bare radio og TV

## The VHF ALOMAR wind radar - ALWIN

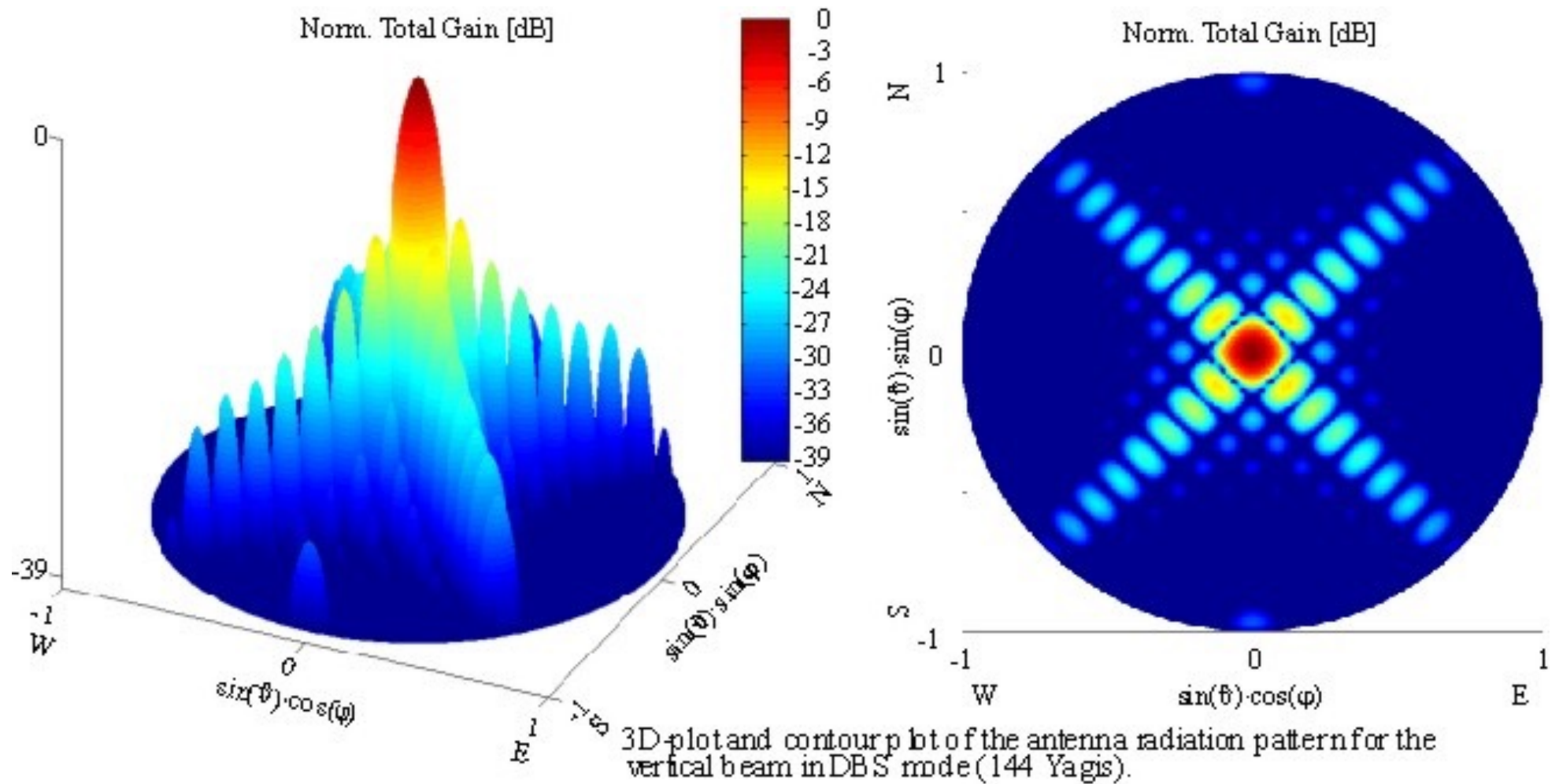

# Middle Atmosphere Alomar Radar System - MAARSY



### Radar experiments on Andøya island (69°N)

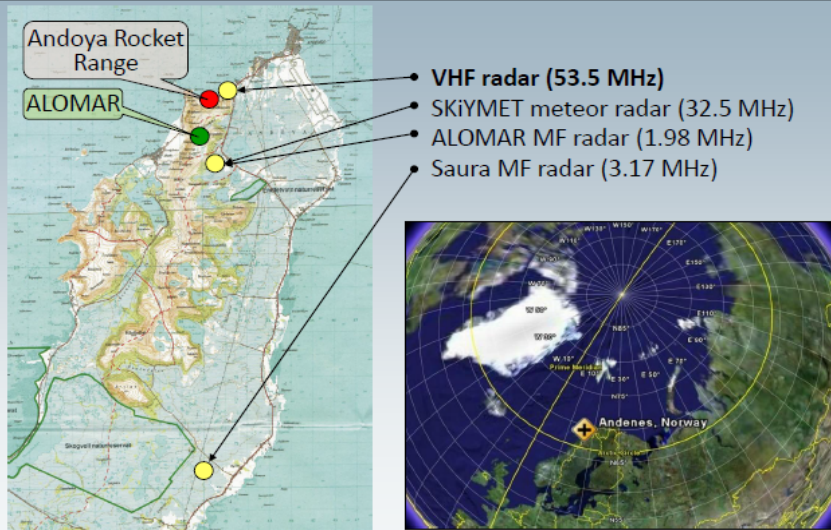

### Polar Mesosphere Summer Echoes

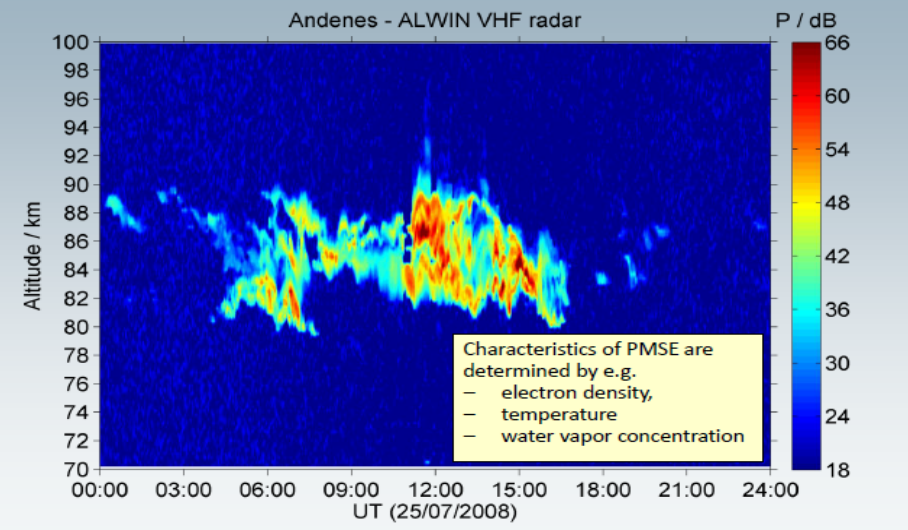

### Mean seasonal variation of PMSE occurrence after radar observations at Andøya from 1999 – 2008

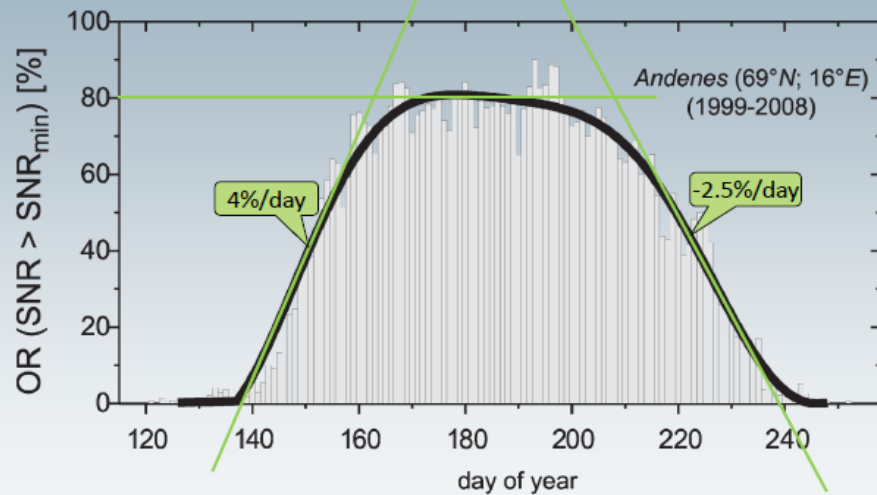

### MAARSY Middle Atmosphere Alomar Radar System





