

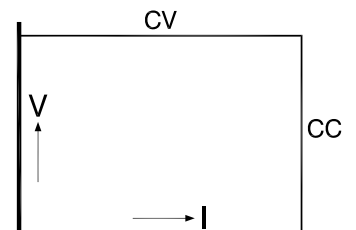

ES 150 - Series 150 W DC POWER SUPPLIES

Models	Voltage range	Current range
ES 015-10	0 - 15 V	0 - 10 A
ES 030-5	0 - 30 V	0 - 5 A
ES 075-2	0 - 75 V	0 - 2 A
ES 0300-0.45	0 - 300 V	0 - 0.45 A



Features

- Very low output ripple and spikes
- EMC surpasses CE requirements: low emission & high immunity
- High programming speed
- Excellent dynamic response to load changes
- Protected against all overload and short circuit conditions
- Designed for a long life at full power

Functionalities

- Master/Slave parallel and series operation with voltage and current sharing
- Voltage and current control with 10 turn potentiometers
- 19" rack mounting or for laboratory use (feet included)
- Remote sensing
- Convection cooling

	ES 015-10	ES 030-5	ES 075-2	ES 0300-0.45
Output voltage current	0 - 15 V 0 - 10 A	0 - 30 V 0 - 5 A	0 - 75 V 0 - 2 A	0 - 300 V 0 - 450 mA
Input AC single phase, 48 - 62 Hz rated voltage range rated frequency Input current @ 230 VAC power factor, 110 / 230 VAC full load DC internal fuses standby input power (Vo=Io=0) standby input power (Vo=Vmax)		90 - 265 V 100 - 240 V 50 / 60 Hz 1 A 0.99 / 0.83 contact factory 4 AT 6 W 11 W		
Efficiency AC 230 V input, full load AC 110 V input, full load	83 % 80 %	84 % 82 %	84 % 81 %	84 % 81 %
Regulation				
Load 0 - 100% CV internal sensing optional external sensing Line 90 - 265 V AC CV	15 mV 2 mV 0.2 mV	6 mV 2 mV 0.5 mV	5 mV 5 mV 1 mV	10 mV 10 mV 3 mV
Load 0 - 100% CC Line 90 - 265 V AC CC (internal voltage sensing)	3 mA 0.5 mA	1 mA 0.2 mA	0.5 mA 0.1 mA	0.3 mA 0.05 mA
Ripple + noise (full load) rms (BW=300 kHz) CV p-p (BW=20 MHz) CV rms (BW=300 kHz) CC p-p (BW=20 MHz) CC	0.5 mV 8 mV 1.5 mA 10 mA	0.6 mV 10 mV 0.5 mA 2 mA	1 mV 15 mV 0.1 mA 0.5 mA	7 mV 50 mV (typical 30 mV) 0.03 mA 0.2 mA
Temp. coeff., per °C CV CC			5.10 ⁻⁵ 10.10 ⁻⁵	
Stability after 1 hr warm-up during 8 hrs CV CC tamb = 25 ± 1 °C, Vin = 230 VAC (internal voltage sensing for CC-stab.)	10.10 ⁻⁵ 10.10 ⁻⁵	10.10 ⁻⁵ 10.10 ⁻⁵	10.10 ⁻⁵ 10.10 ⁻⁵	10.10 ⁻⁵ 12.10 ⁻⁵

Analog Programming	CV	CC
Programming inputs input range accuracy offset temp. coeff. offset input impedance	0 - 5 V ± 0.2% 0 ... + 3 mV (on 5 V) 10 µV / °C 1 MOhm	0 - 5 V ± 0.8% 0 ... + 10 mV (on 5 V) 60 µV / °C 1 MOhm
Monitoring output output range accuracy offset temp. coeff. offset output impedance	0 - 5 V ± 0.2% - 1 ... + 1 mV (on 5 V) 10 µV / °C 2 Ohm / max. 4 mA	0 - 5 V ± 0.8% - 10 ... 0 mV (on 5 V) 60 µV / °C 2 Ohm / max. 4 mA

Reference voltage on prog. connector TC	Vref	5.137 ± 10 mV (Ro = 2 Ohm, max. 4 mA) 50 ppm
+12 V output on prog. Connector	Vo Ro	12 V ± 0.5 V 100 Ohm

Status output CC - status	CC - operation	5 V / 5 mA = logic 1
Remote shutdown	with + 5 V, 1 mA or relay contact	
Indicators (front panel)	CV-mode, CC-mode	
Controls (front panel)	Mains on/off, CV- and CC-potmeter	

Programming speed (resistive load)	ES 015-10	ES 030-5	ES 075-2	ES 0300-0.45
Rise time (10 - 90%) output voltage step time, (100% load) time, (10% load)	0 → 15 V 7 ms 3 ms	0 → 30 V 15 ms 6 ms	0 → 75 V 17 ms 7 ms	0 → 300 V 10 ms 4 ms
Fall time (90 - 10%) output voltage step time, (100% load) time, (10% load)	15 → 0 V 7 ms 70 ms	30 → 0 V 15 ms 150 ms	75 → 0 V 17 ms 160 ms	300 → 0 V 10 ms 100 ms

	ES 015-10	ES 030-5	ES 075-2	ES 0300-0.45
Recovery time recovery within di/dt of load step time, @ 50 - 100% load step max. deviation @ 230 VAC input voltage	50 mV 250 mA/μs 100 μs 160 mV	50 mV 125 mA/μs 100 μs 160 mV	50 mV 70 mA/μs 100 μs 150 mV	200 mV 6 mA/μs 130 μs 700 mV
Output impedance CV, 0-100 kHz	< 100 mOhm	< 200 mOhm	< 250 mOhm	< 5 Ohm
Pulsating load max. tolerable AC component of load current f > 1 kHz f < 1 kHz	2 A rms 10 A peak	2 A rms 5 A peak	2 A rms 2 A peak	2 A rms 0.45 A peak

Insulation input / output creepage / clearance input / case output / case	3750 Vrms (1 min.) 8 mm 2500 Vrms 600 V DC
Safety	EN 60950 / EN 61010
EMC Power Supply Standard Generic Emission Generic Immunity	EN 61204-3 , Emission: residential, light industrial environment (CISPR22-Class B) Immunity: industrial environment EN 61000-6-3 , residential, light industrial environment (EN 55022 B) EN 61000-6-2 , industrial environment
Operating Temperature at full load	- 20 to + 50 °C derate output to 75% at 60 °C
Humidity	max. 95% RH, non condensing, up to 40 °C max. 75% RH, non condensing, up to 50 °C
Storage temperature	- 40 to + 85 °C
Thermal protection	Output shuts down in case of insufficient cooling
MTBF	500 000 hrs

Hold-Up time (230 VAC input) Vout = 100% , Iout = 100% Vout = 85% , Iout = 100% Vout = 100% , Iout = 50%	25 ms 40 ms 60 ms
Turn on delay (230 VAC input) after mains switch on	250 ms
Inrush current	10 A with NTC resistor 30 Ohms cold resistance

	ES 015-10	ES 030-5	ES 075-2	ES 0300-0.45
Series operation max. total voltage Master / Slave operation	600 V with optional external Master/Slave Adapter			
Parallel operation max. total current Master / Slave operation	no limit max. 4 units			
Remote sensing (optional)	option P119	option P120	option P121	option P122
max. voltage drop per load lead	2 V <i>Note: voltage drop across load leads will subtract from max. available output voltage</i>			
Over Voltage Limit (fixed)	max. 18 V	max. 40 V	max. 90 V	max. 330 V
Potentiometers front panel control with knobs resolution screwdriver adjustment at front panel	standard 0.03% option P001			
Meters scale voltage scale current accuracy V-meter accuracy A-meter	3.5 digit 0 - 15.00 V 0 - 10.00 A 0.5% + 2 digits 1% + 2 digits	3.5 digit 0 - 30.0 V 0 - 5.00 A 0.5% + 2 digits 1% + 2 digits	3.5 digit 0 - 75.0 V 0 - 2.00 A 0.5% + 2 digits 1% + 2 digits	3.5 digit 0 -300 V 0 - 450 mA 0.5% + 2 digits 1% + 2 digits

Input Connector	Euro-connector at rear panel 10 Amp / 65 °C IEC320/C14, EN60320/C14
Output Terminals	Standard: 4 mm safety sockets at front-panel Option: screw terminals (0.2-4 mm ²) at rear-panel (sockets at front removed) only combined with remote sensing, see remote sensing for option numbers (P119 - 122)
Programming connector	15 pole D-connector at rear panel (FEMALE)
Cooling	Convection cooling
Enclosure degree of protection	IP20
Dimensions (h x w x d)	52 x 222 x 202 mm
Weight	1.7 kg

CV = Constant Voltage
CC = Constant Current

OVL = Over Voltage Limit

Specifications measured at $t_{amb} = 25 \pm 5^\circ C$ and $V_{in} = 230 VAC, 50 Hz$ unless otherwise noted.

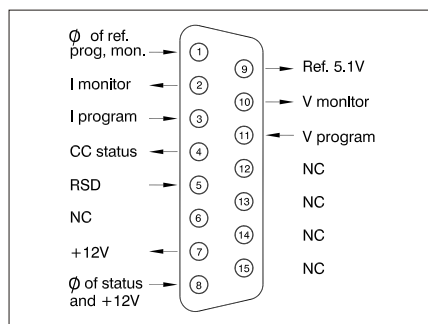

Connections programming connector

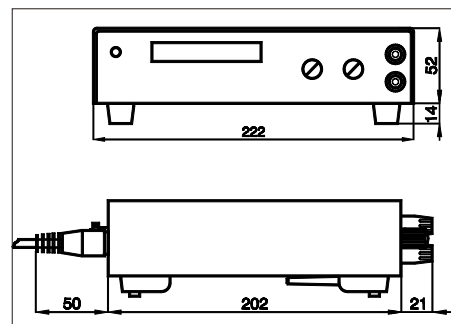

Dimensions

Typical Applications

- Test and measurement
- Controlled battery charging
- Electronic Circuit Development
- Component device testing
- ATE in industrial production lines
- Laboratory analysis
- Medical research equipment
- Accurate current sources

Available Options



Increased Output Power

The conservatively rated unit allows to deliver extra output with the same reliability. At some derating, either the maximum output voltage or the maximum output current can be increased by about 10%.

- Order Code - P069

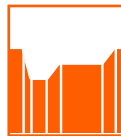

Sequencer

Arbitrary Waveform generator or standalone automation. The sequencer is integrated in the Ethernet controller.

- Order Code - P150



Secured Voltage and Current Setting

For a maximum security, the CV/CC settings can be adjusted with a screwdriver only and are protected with a plastic cap from accidental adjusting.

- Order Code - P001



Rear Power Output and Remote Sensing

Output terminals at the rear panel instead of bind posts at the front panel, includes remote sensing.

- Order Code ES015-10 - P119
- Order Code ES030-5 - P120
- Order Code ES075-2 - P121
- Order Code ES0300-0.45 - P122



19" Rack Mounting Adapter

Using the 19" mounting adapters, it is possible to position the ES units in a 19" rack. Several configurations possible with multiple ES and / or PSC or ISO AMP modules.



Software control and Interfaces

Factory installed programming interfaces:

- RS232 controller - P148
- Ethernet contr. (incl. sequencer) - P150
- PROFIBUS controller - P279
- CANBUS controller - P280

External programming interface modules :

- IEEE488 controller module
- ISO AMP module

- Notes:
1. Download the special datasheet about Battery Charging from www.DeltaPowerSupplies.com.
 2. There is only room for one of the interfaces in a unit, see next page for configurations.
 3. Units with option P089 have the analog programming connector removed and can be combined with P148. These units cannot be combined with P150, P279 or P280.

19" rack mounting



Rear Connections

Standard unit:
Analog programming

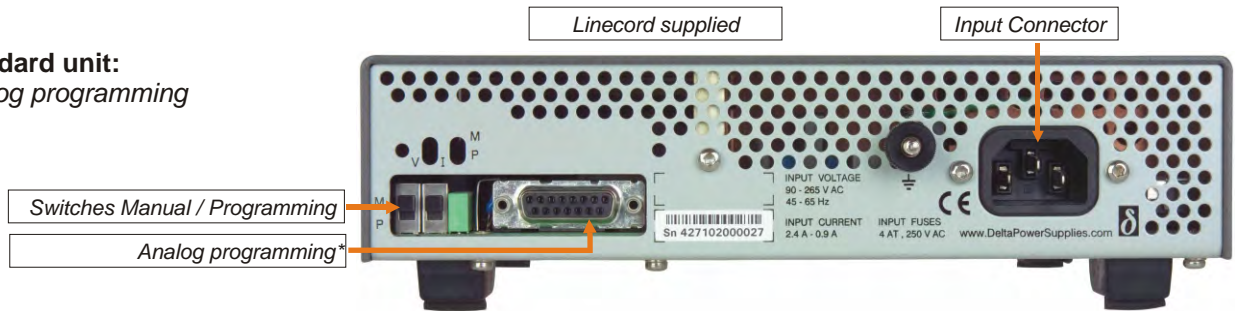

Option P150:
Ethernet programming

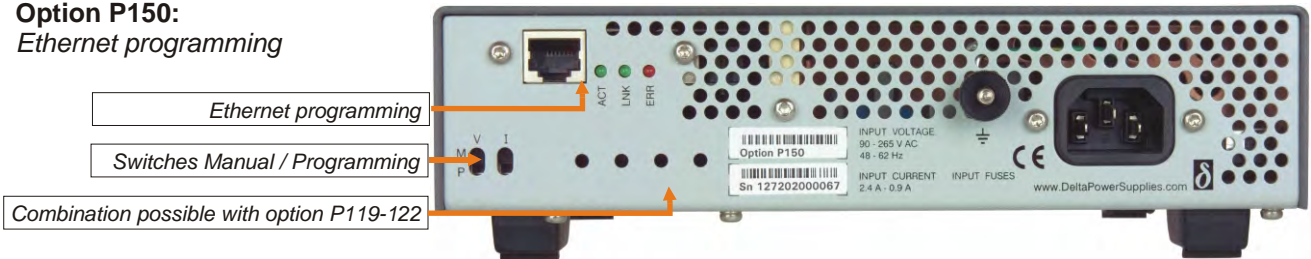

Option P148:
RS232 programming



Option P119 - 122:
Rear power outlet / rem. sensing

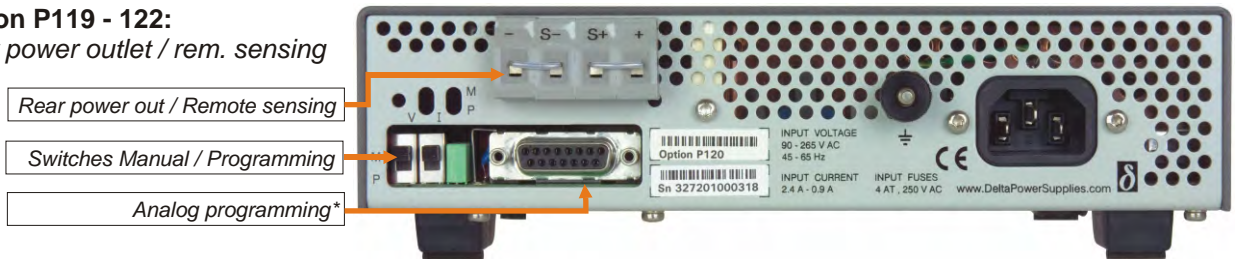

*Note: Units with Option P089 have the analog programming connector removed.

