

Sensor krav og motivasjon

2 1 Data Acquisition

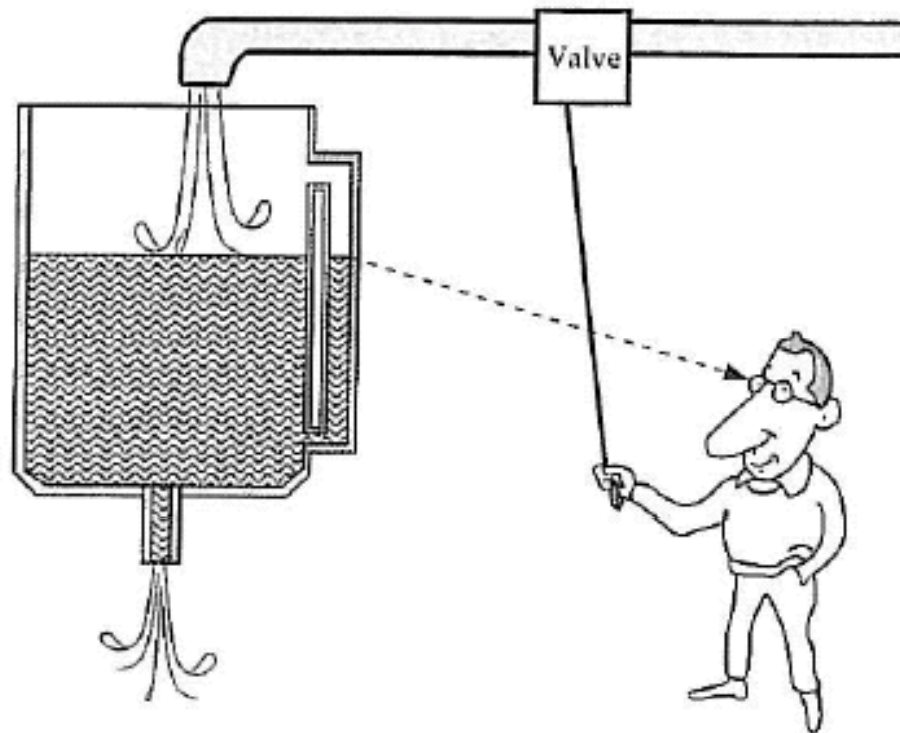
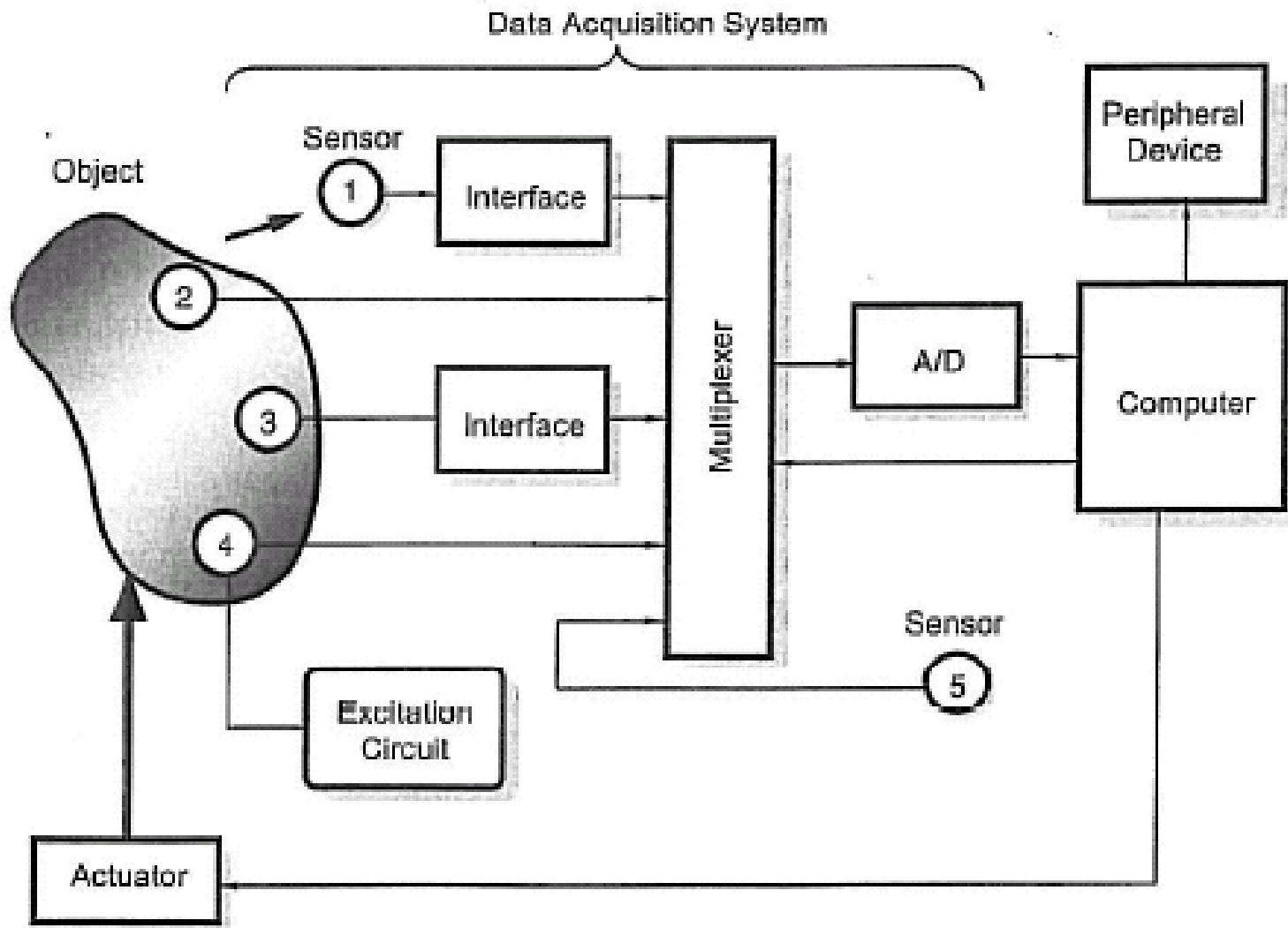
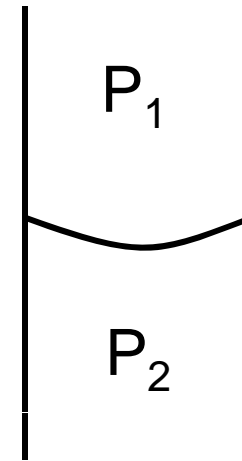
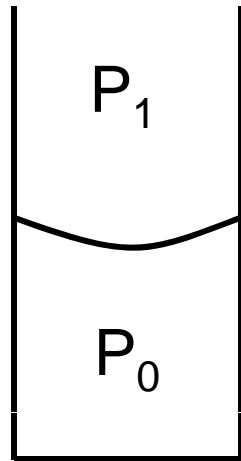

Fig. 1.1. Level-control system. A sight tube and operator's eye form a sensor (a device which converts information into electrical signal).

Målesystem (Fraden)



Absolutt eller relativ sensor



Statisk og dynamisk karakteristikk

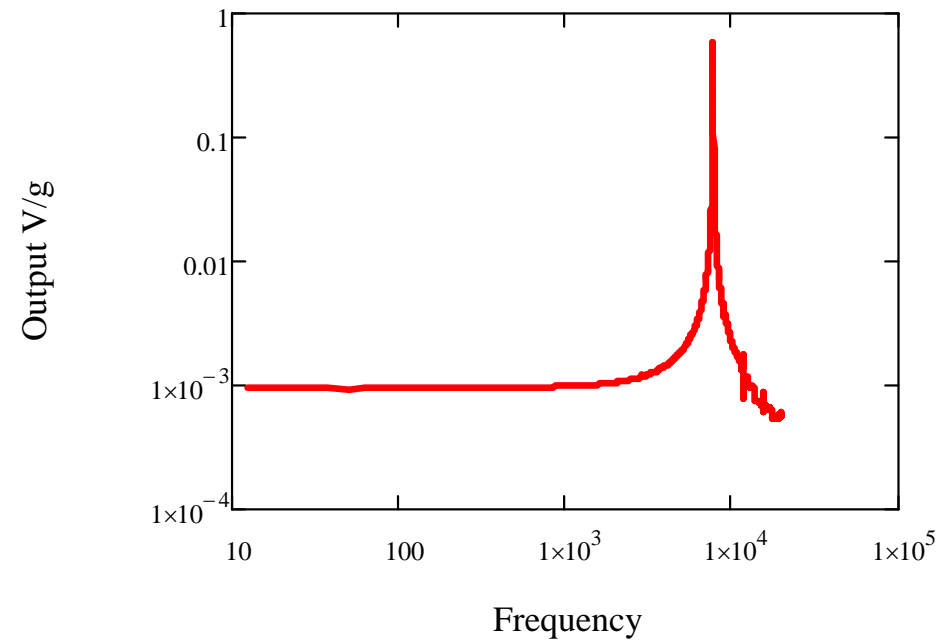
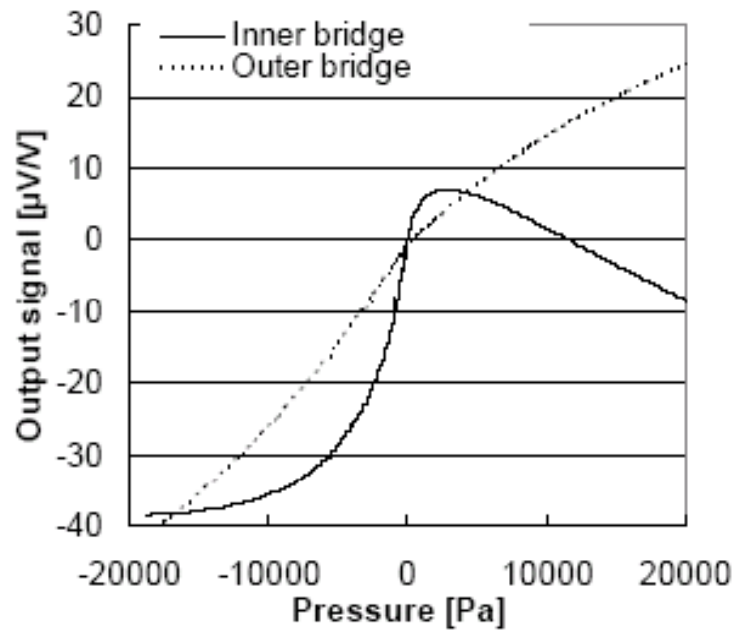

Dynamikk - amplitude

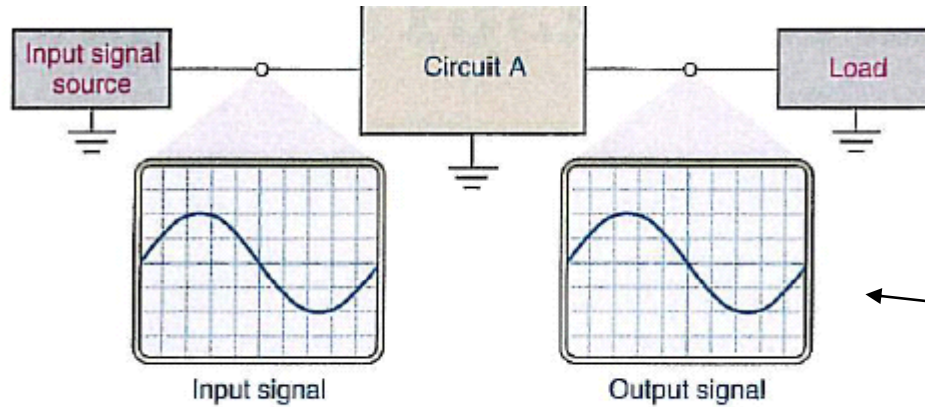

(a) Circuit A input and output signals at a given frequency (f).

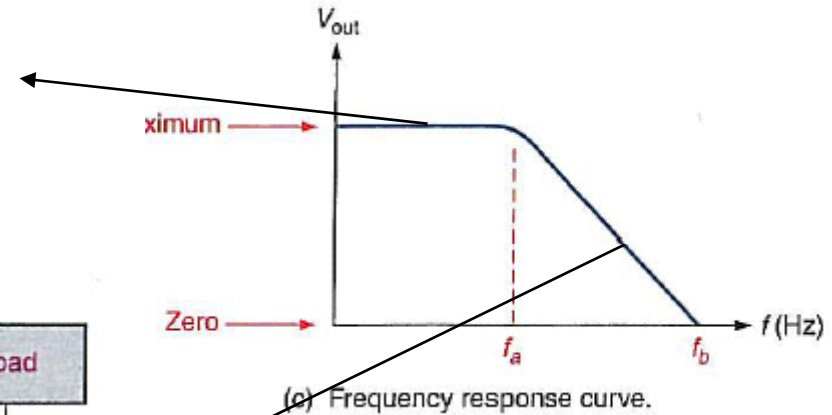
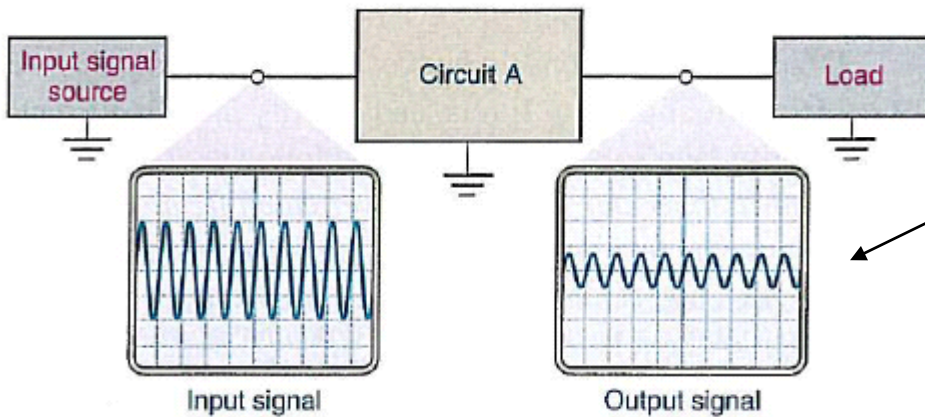

(c) Frequency response curve.

2. ordens system

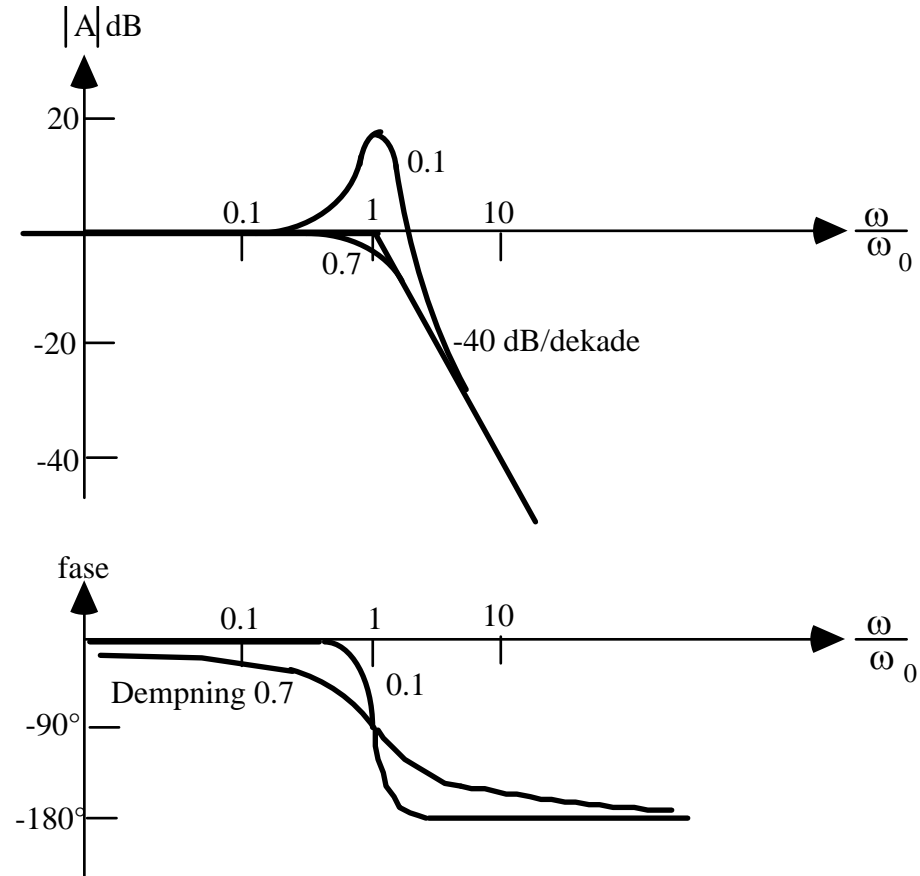
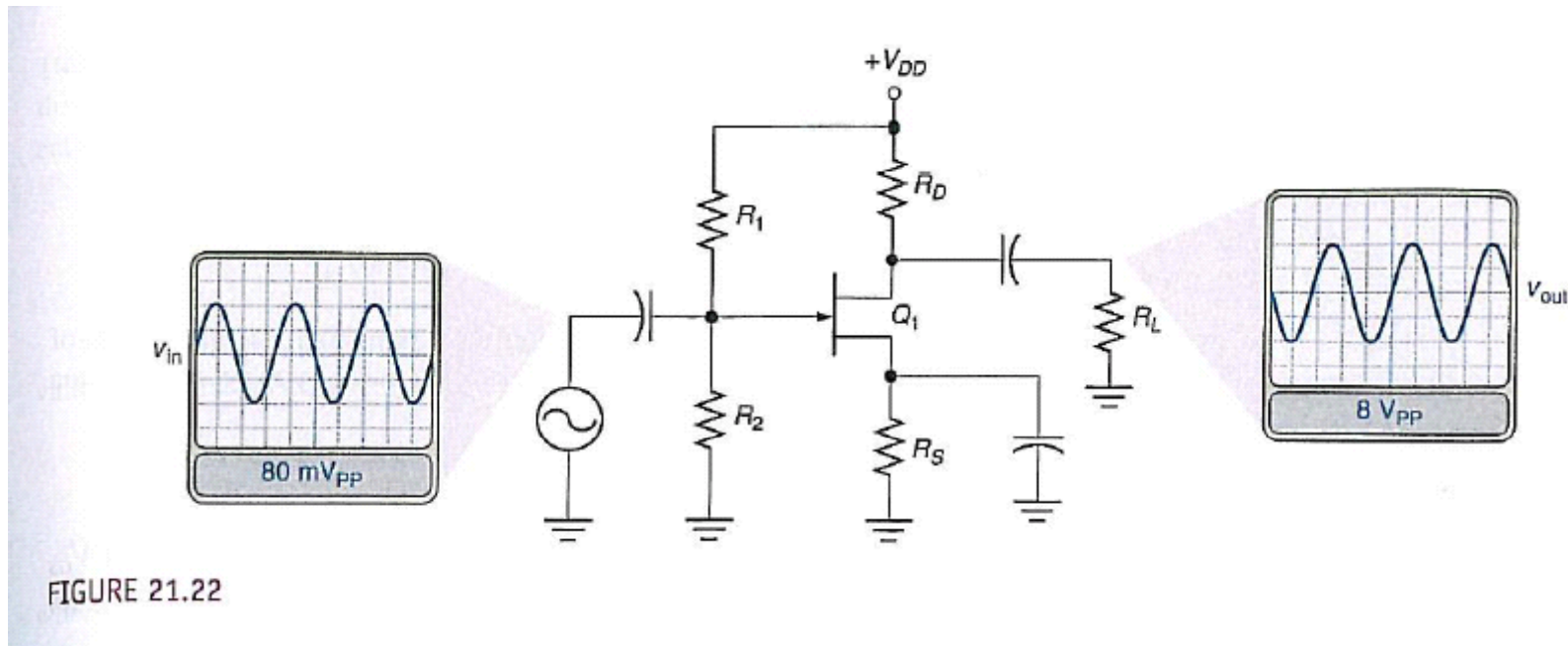

Fig. 5.7 Modul- og fase-forløp for dempning lik 0.1 og 0.7.

Dynamikk - fase



Ekspponentsiell respons - STM

$$I \propto e^{-\frac{d}{d_0}}$$

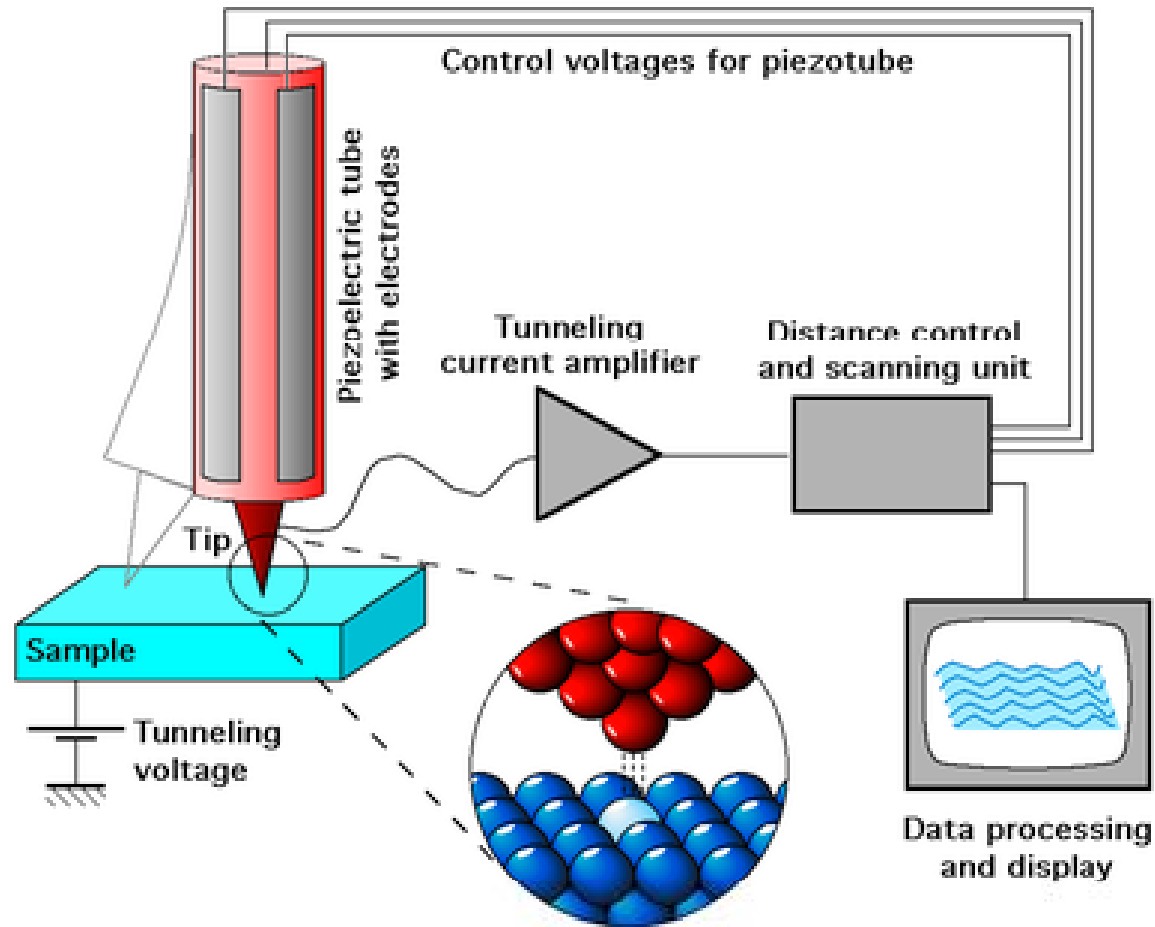
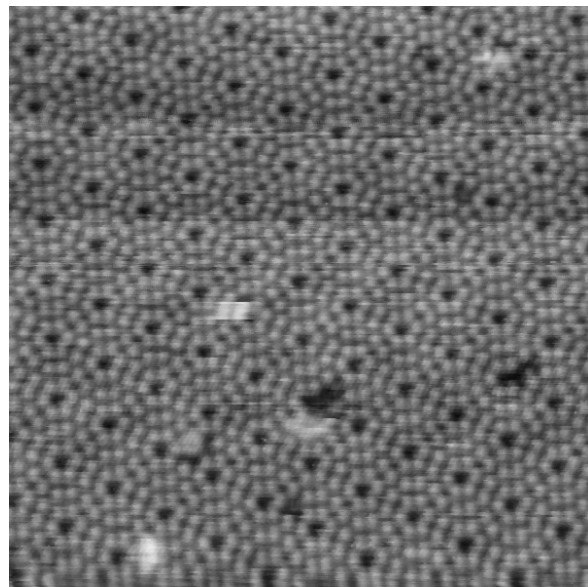

Wikipedia

EkspONENT respons - pyrometer

Utstrålt effekt

$$V = G(T_b^4 - T_s^4)$$

Følsomhet

$$b = \frac{\partial V}{\partial T_b} = 4GT_b^3$$

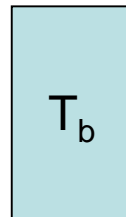

Pyrometer's
**EMISSIVITY
CALCULATOR**

*Determine true temperature
with Pyrometer's exclusive
ePyroCal Emissivity Calculator.*

Click here >>

www.pyrometer.com

Følsomhet

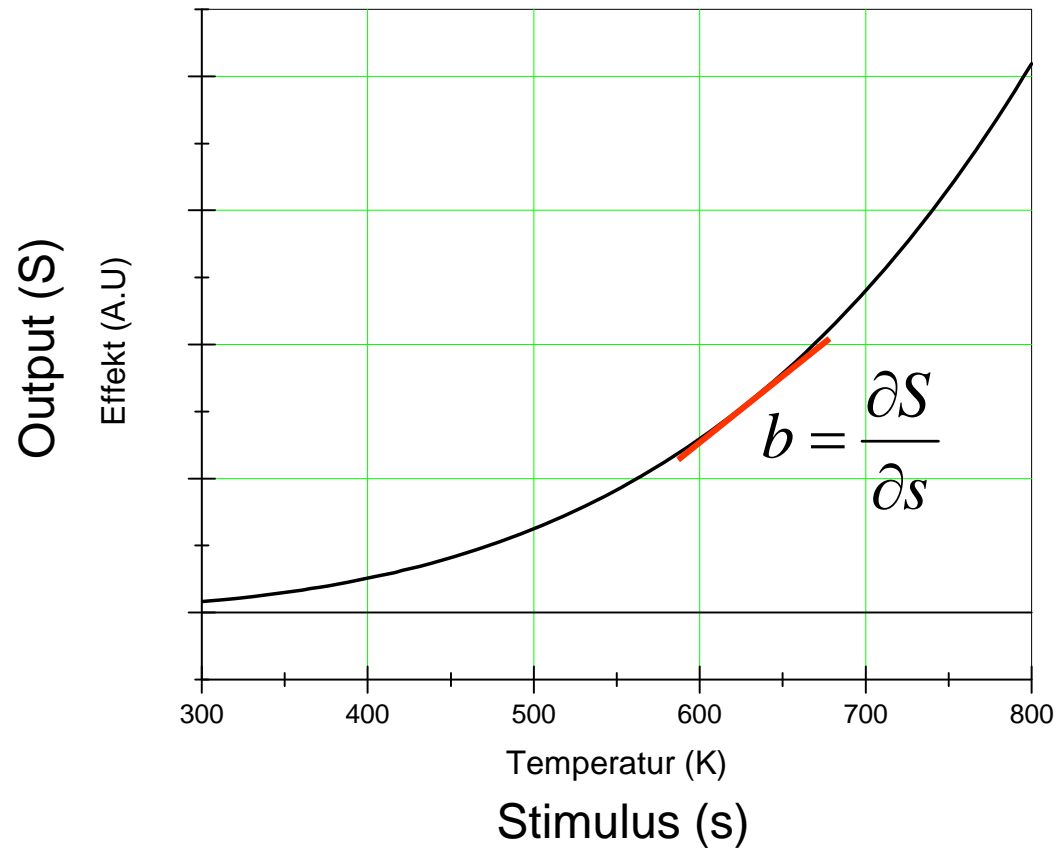

Lineær respons

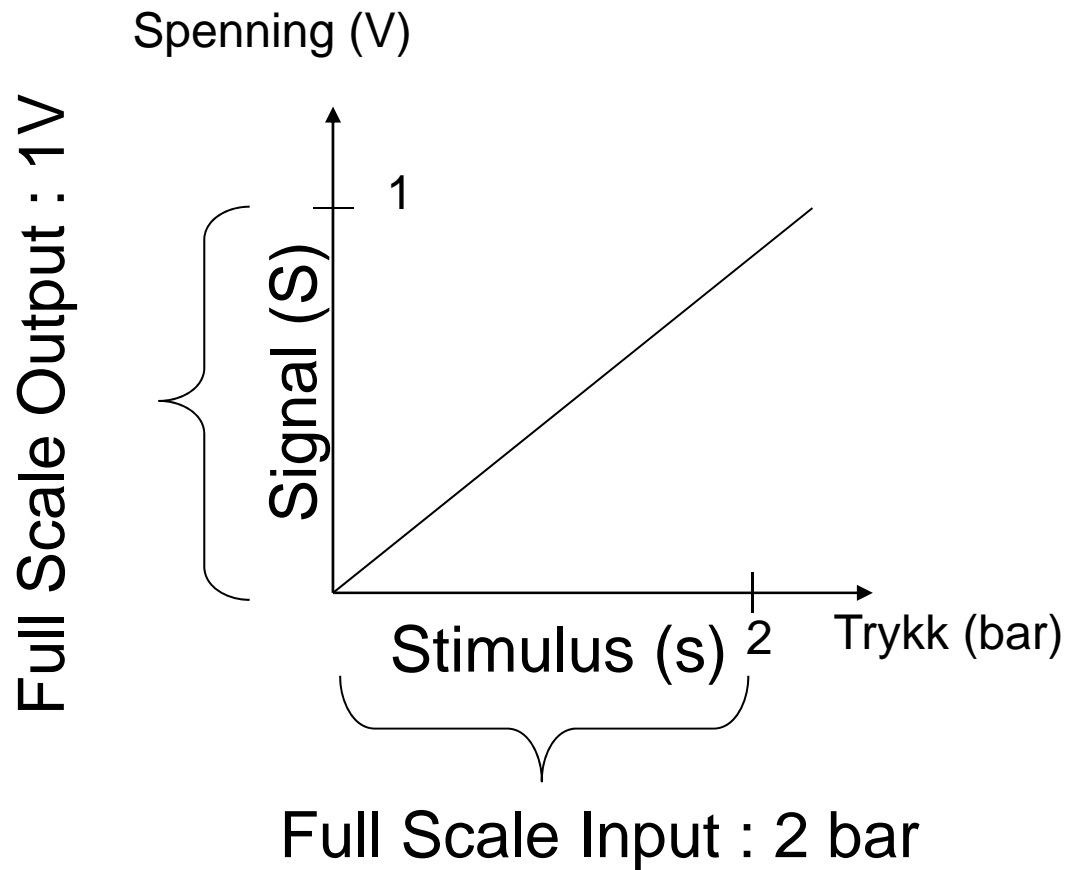

$$S = b \cdot s$$

$$b = 0.5 \text{ V/bar}$$

Span og range

Output range $\pm 1V$
Output span 2V

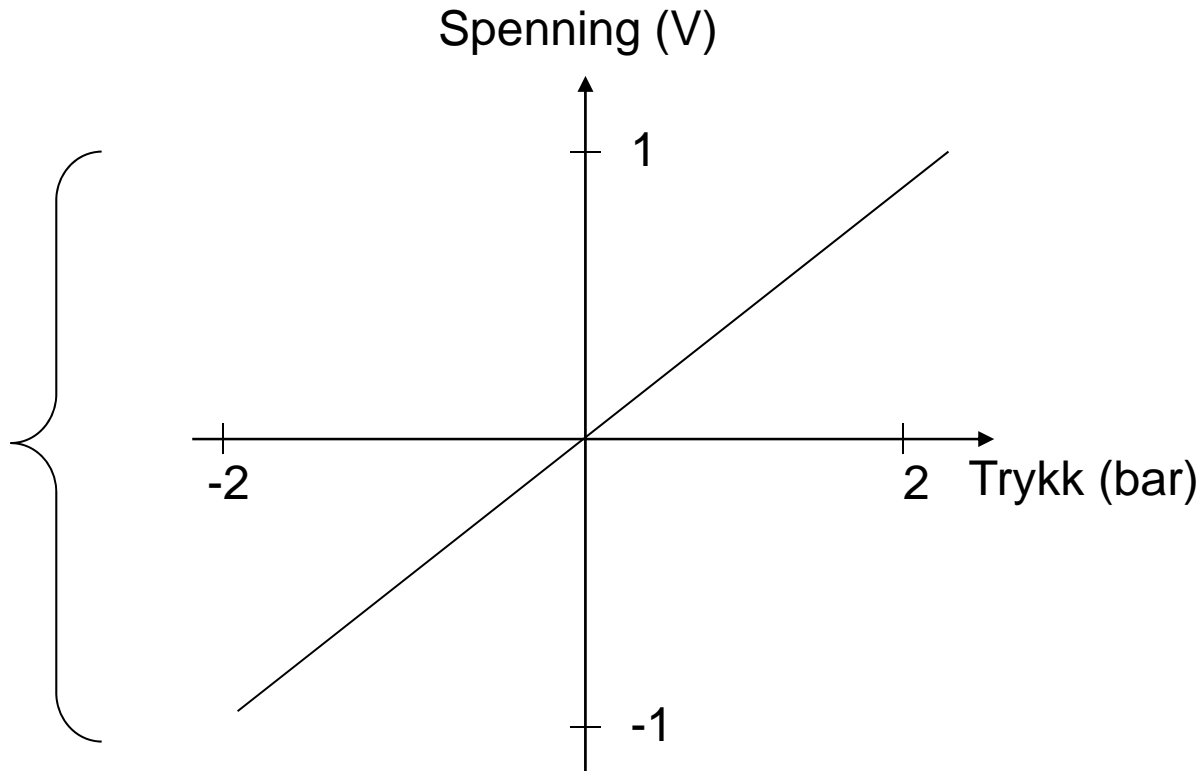





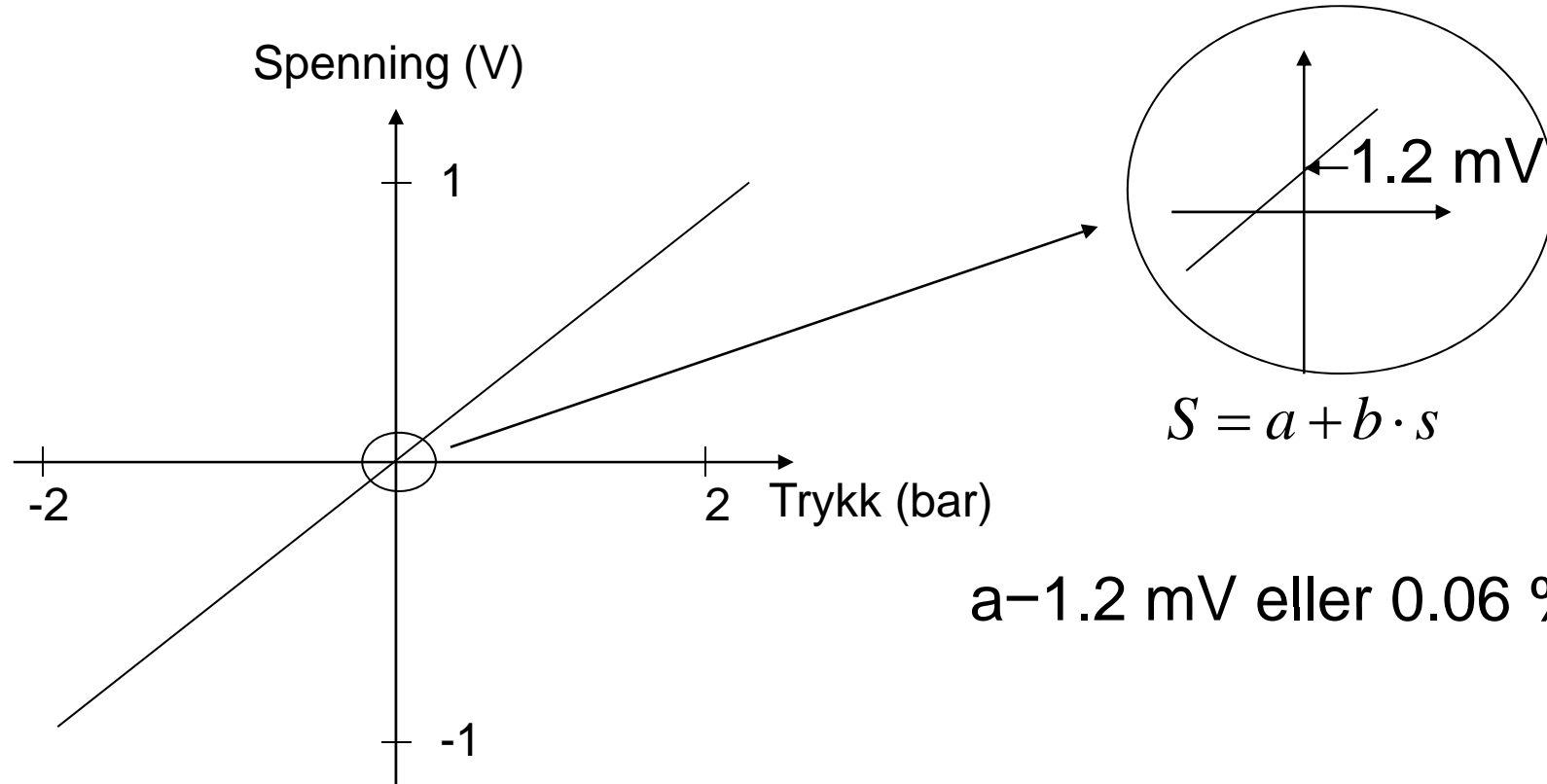











Input range: ± 2 bar
Input span: 4 bar

Offset (nullpunktsavvik)



a -1.2 mV eller 0.06 % FS

Sensor spesifikasjoner

Info	Type	Preview	Transducer for	Nominal meas. range in bar	Accuracy class [%]	Service range [%]	Nominal temperature [°C]	Max. medium temperature [°C]
 P3MBP BlueLine			High-Pressure up to 15000 bar	5000, 10000, 15000	0.2, 0.4, 0.5	120	-10 ... +80	+100
 P15			gage pressure	0...10 - 0...500	1	0...200	-20...+70	+105
 P2V			absolute pressure	200, 500, 1000, 2000, 3000, 5000	0.2 (5000 bar: 0.4)	0...105	0...+70	
 P3MB			absolute pressure	0...10 - 0...3000	0.1 / 0.15 / 0.2	0...100 / 0..150 / 0..200	-10...+80 / -20...+80	+100
 P3MBP/2kb-PT100			absolute pressure	2000	0.2	150	+20 ... +70	100
 P6A			absolute pressure	0...10 - 0...500	0.2	0...200 / 0...150	-10...+80	+100
 P8AP			absolute pressure	0...10 - 0...500	0.3	0...150	-10...+70	+100 / +140
 PE300			gage pressure	0...10 - 0...2000	0.15 / 0.2 / 0.3	-10...+110	-20...+70	+110

Input karakteristik

Specifications according to DIN 16086

Type		P2VA1 (output signal in V) ¹⁾	P2VA2 (output signal in mA)
Measuring ranges	bar	200, 500, 1000, 2000, 3000	5000
Input quantities			
Pressure type		Absolute pressure	
Accuracy class		0.2	0,3
Initial value	bar	0	
Operating range at reference temperature	%	0 to approx. 110 / 105	
Overload limit at reference temperature	%	150	
Test pressure	%	200	150
During dynamic loading			
Permissible pressure	%	100	
Permissible vibration amplitude according to DIN 50 100	%	70	
Dead volume approx.	cm ³	0.8	
Control volume, approx.	mm ³	1.5	
Materials from which components in contact with the measurement medium are made		1.4542 (measuring body) 1.4701 (seals)	
Auxiliary energy			
Reference voltage	V	24	
Nominal (rated) range	V	15 ... 30 ²⁾	
Effect of supply voltage on changing from 15 to 30 V	%	0.02	
Max. current consumption (for the P2VA2, excluding loop current)	mA	25	
Max. power consumption	W	<1 <2	

Output karakteristik

Output characteristics			
Transducer identification		TEDS	
Signal span (sensitivity)	V	0.5 ... 10	
	mA	4...20 (16)	
Zero signal, adjustment tolerance (factory)	V	< ±0.010	±0,020
	mA	< ±0.016	±0.032
Sensitivity tolerance	V	< ±0.010	±0.020
	mA	< ±0.016	±0.032
Maximum signal	V	10,5	
	mA	21.6	
Temperature influence on zero signal in the nominal (rated) excitation voltage range per 10 K, by refer- ence to the nominal (rated) sensitivity	% / 10K	0.2	
Effect of temperature on sensitivity in the nominal (rated) excita- tion voltage range per 10 K, by reference to the actual value	% / 10K	0.2	
Characteristic curve deviation (start setting)	%	0.3	
Repeatability according to DIN 1319	%	< ±0.05	
Cut-off frequency			
	-3 dB	kHz	4.5
-1 dB	kHz	2	
Burden, min. / max.	Ω	10000 / 500	

Miljøeffekter

90C

23 C

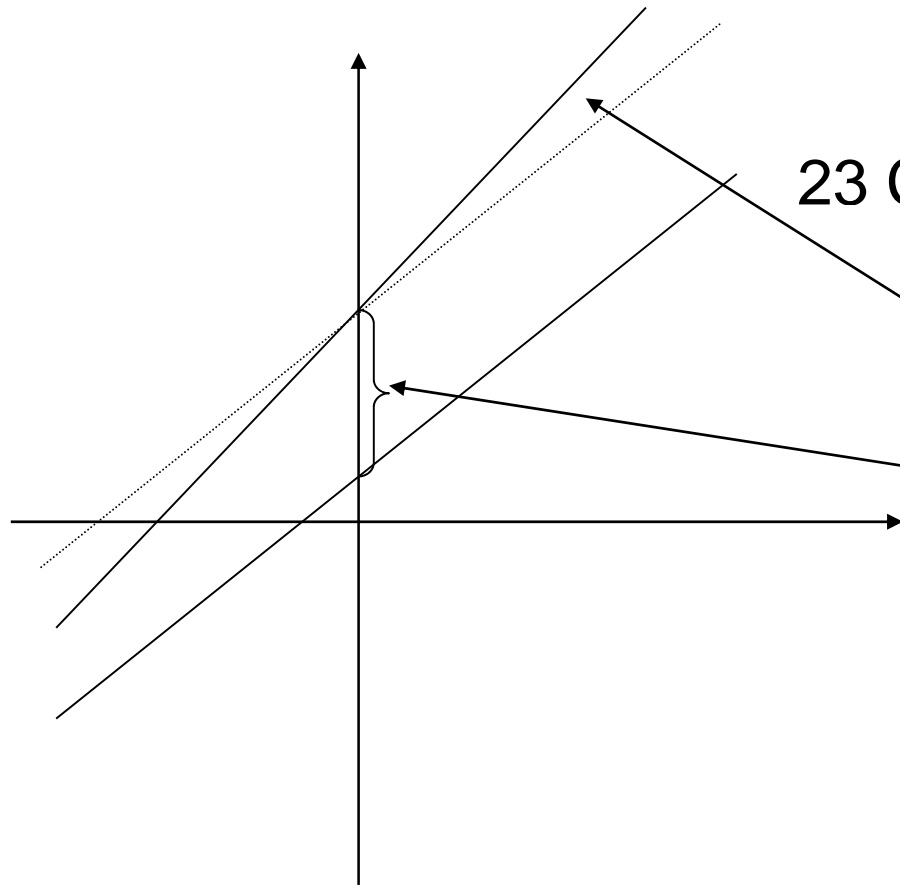

$$O = (K + K_M I_M)I + a + K_I I_I + N(I)$$

S

S

Linearitet

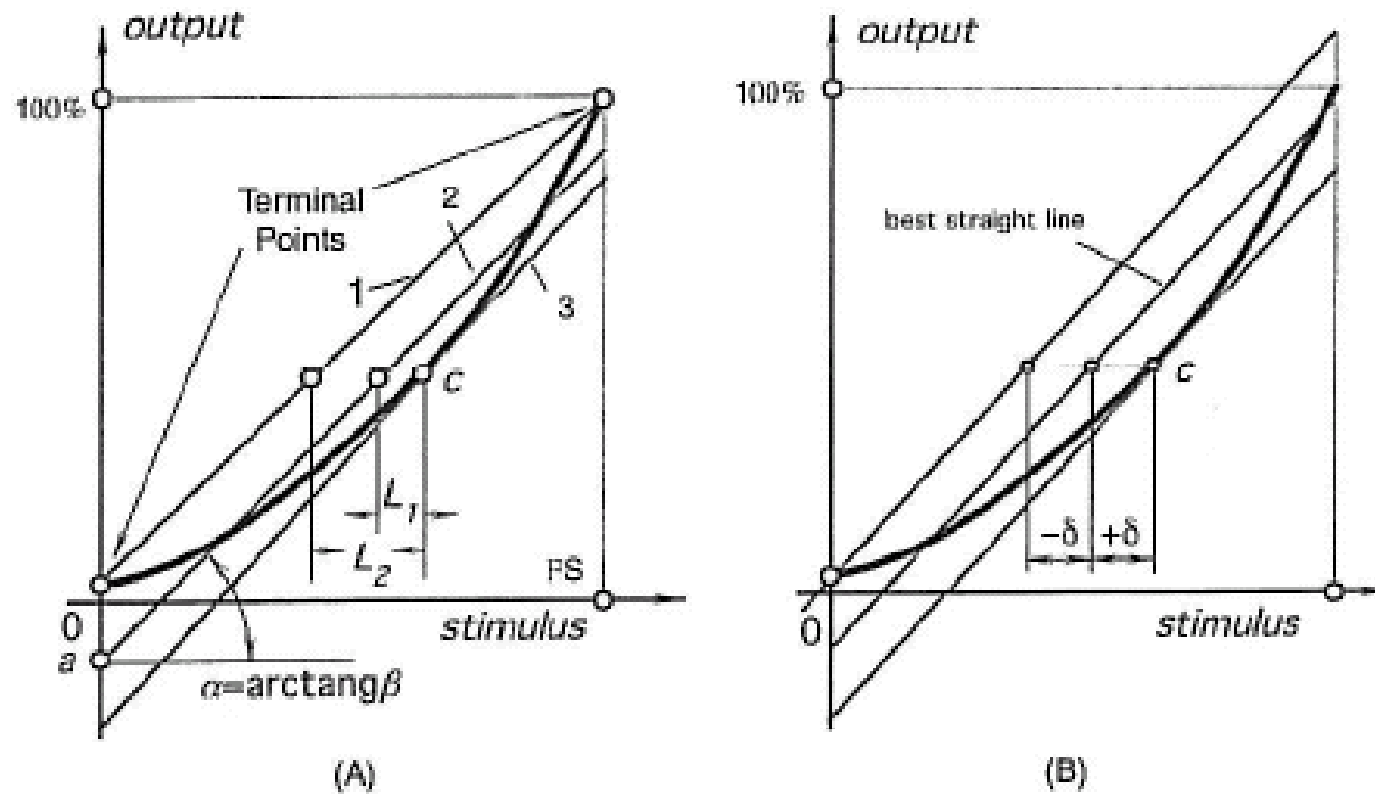

Fig. 2.5. Linear approximations of a nonlinear transfer function (A) and independent linearity (B).

Kalibreringsfeil

20 2 Sensor Characteristics

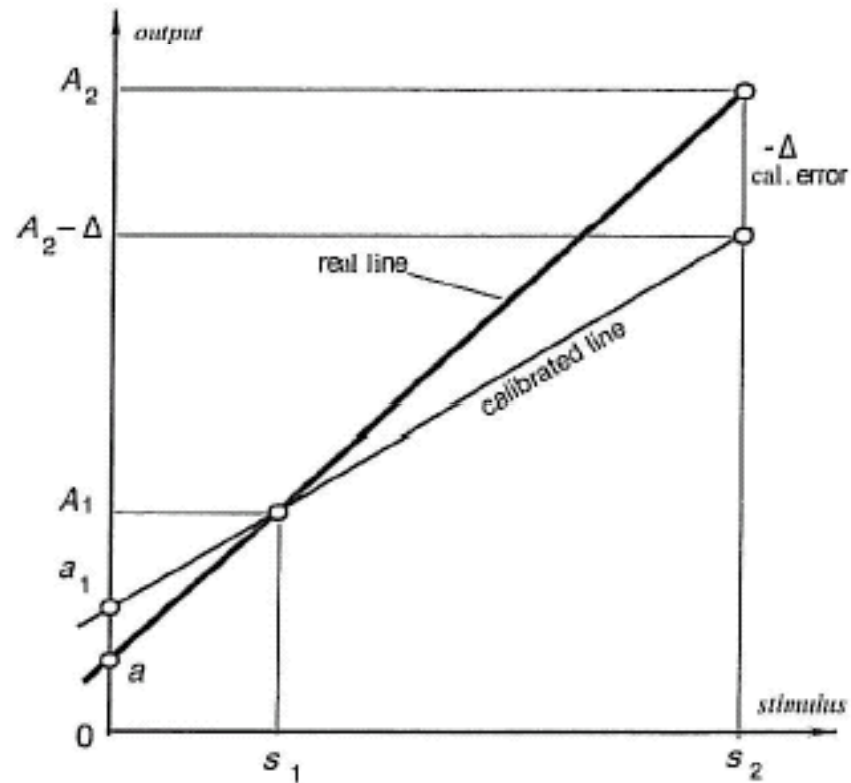
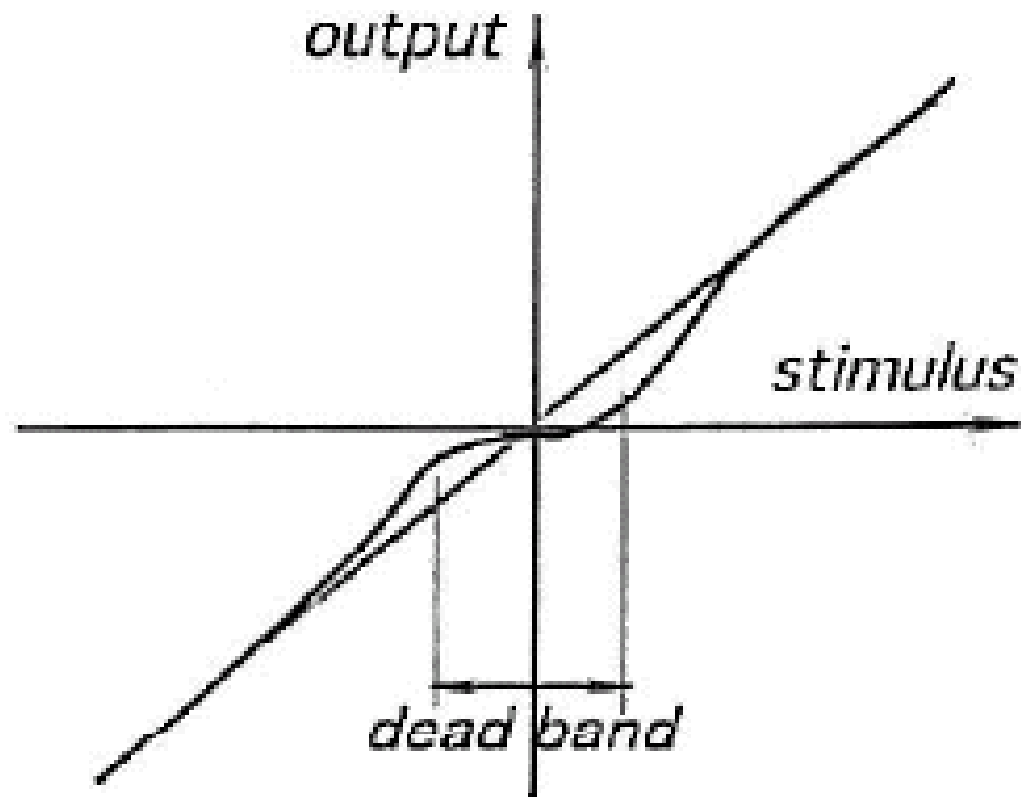

Fig. 2.3. Calibration error.

Vanligvis mye mer komplekst!!

Dødbånd



(B)

Repetierbarhet

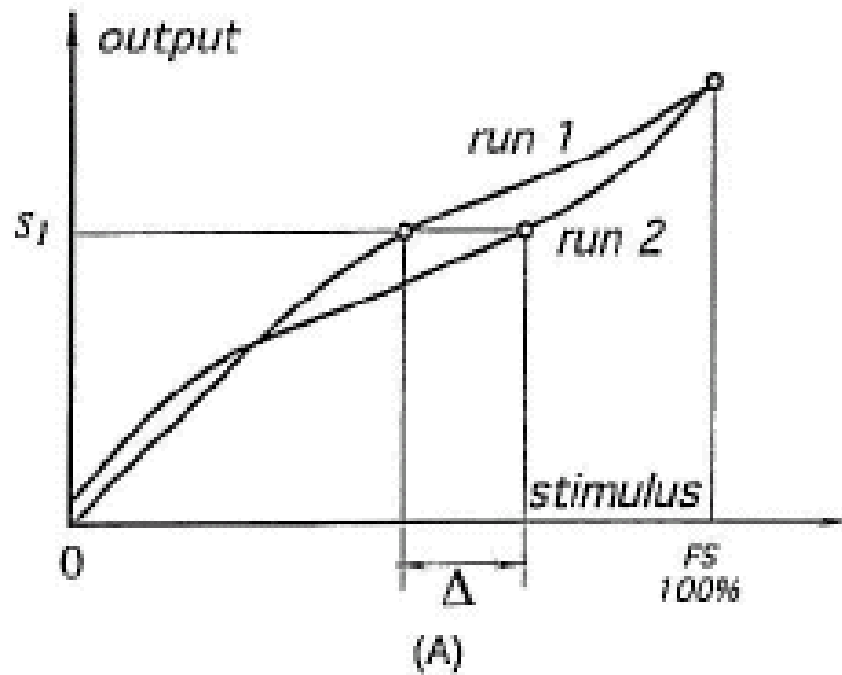

Fig. 2.7. (A) The repeatability error. The same output signals. (B) The dead-band zone in a transfer

Hysteresis

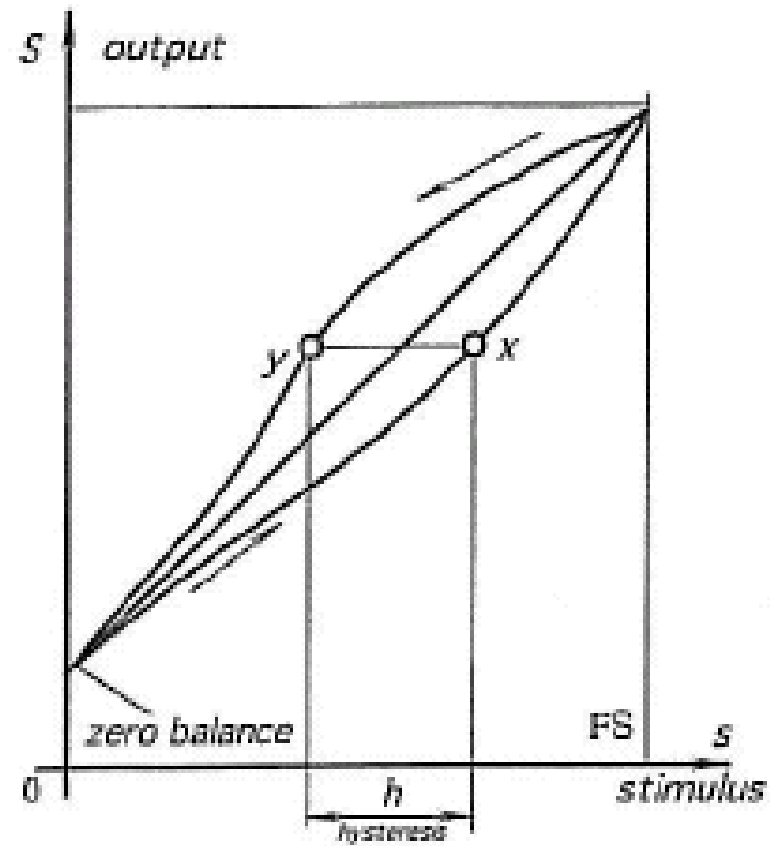

Fig. 2.4.

Ulineær kalibrering

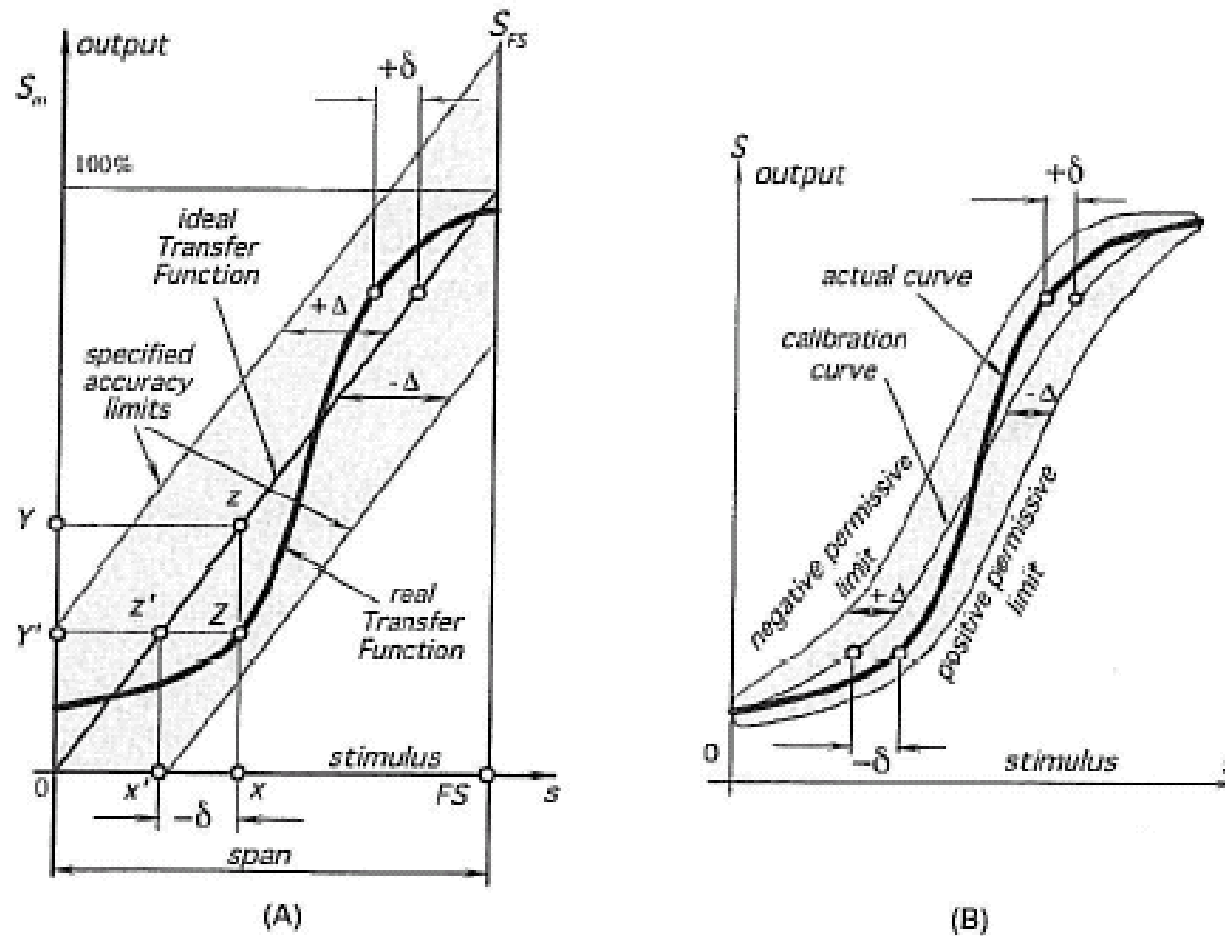

Fig. 2.2. Transfer function (A) and accuracy limits (B). Error is specified in terms of input value.

Oppløsning - fysisk

256 7 Position, Displacement, and Level

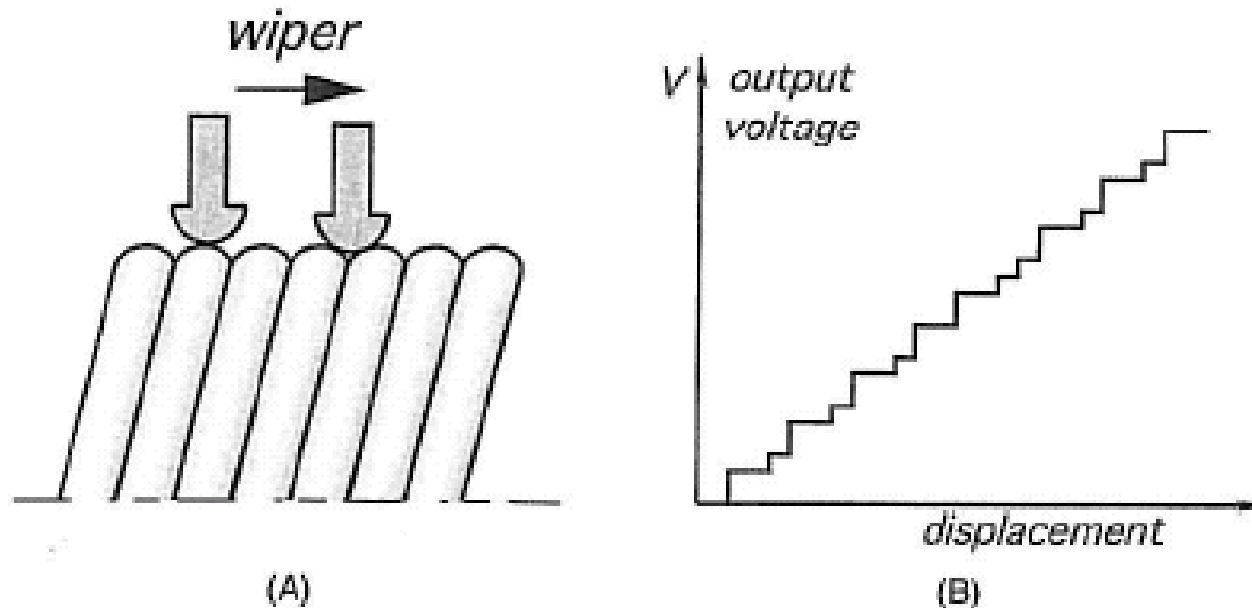
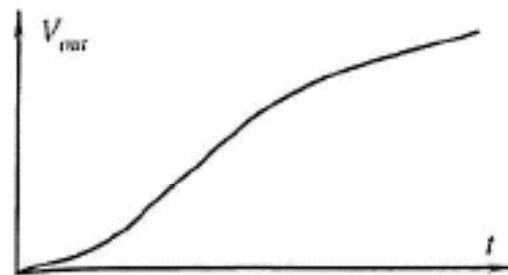
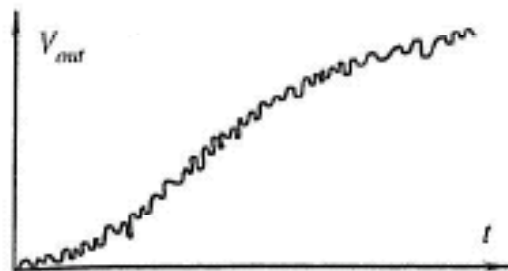

Fig. 7.2. Uncertainty caused by a wire wound potentiometer: (A) a wiper may contact one or two wires at a time; (B) uneven voltage steps.

Oppløsning - Støybegrensning



(A)



(B)



(C)

Fig. 5.46. Types of noise: (A) noise-free signal; (B) additive noise; (C) multiplicative noise.

Digital oppløsning

Table 5.2. Binary Bit Weights and Resolutions

Bit	2^{-n}	$1/2^n$ Fraction	dB	$1/2^n$ Decimal	%	ppm
FS	2^0	1	0	1.0	100	1,000,000
MSB	2^{-1}	1/2	-6	0.5	50	500,000
2	2^{-2}	1/4	-12	0.25	25	250,000
3	2^{-3}	1/8	-18.1	0.125	12.5	125,000
4	2^{-4}	1/16	-24.1	0.0625	6.2	62,500
5	2^{-5}	1/32	-30.1	0.03125	3.1	31,250
6	2^{-6}	1/64	-36.1	0.015625	1.6	15,625
7	2^{-7}	1/128	-42.1	0.007812	0.8	7,812
8	2^{-8}	1/256	-48.2	0.003906	0.4	3,906
9	2^{-9}	1/512	-54.2	0.001953	0.2	1,953
10	2^{-10}	1/1,024	-60.2	0.0009766	0.1	977
11	2^{-11}	1/2,048	-66.2	0.00048828	0.05	488
12	2^{-12}	1/4,096	-72.2	0.00024414	0.024	244
13	2^{-13}	1/8,192	-78.3	0.00012207	0.012	122
14	2^{-14}	1/16,384	-84.3	0.000061035	0.006	61
15	2^{-15}	1/32,768	-90.3	0.0000305176	0.003	31
16	2^{-16}	1/65,536	-96.3	0.0000152588	0.0015	15
17	2^{-17}	1/131,072	-102.3	0.00000762939	0.0008	7.6
18	2^{-18}	1/262,144	-108.4	0.000003814697	0.0004	3.8
19	2^{-19}	1/524,288	-114.4	0.000001907349	0.0002	1.9
20	2^{-20}	1/1,048,576	-120.4	0.0000009536743	0.0001	0.95

Linearisering

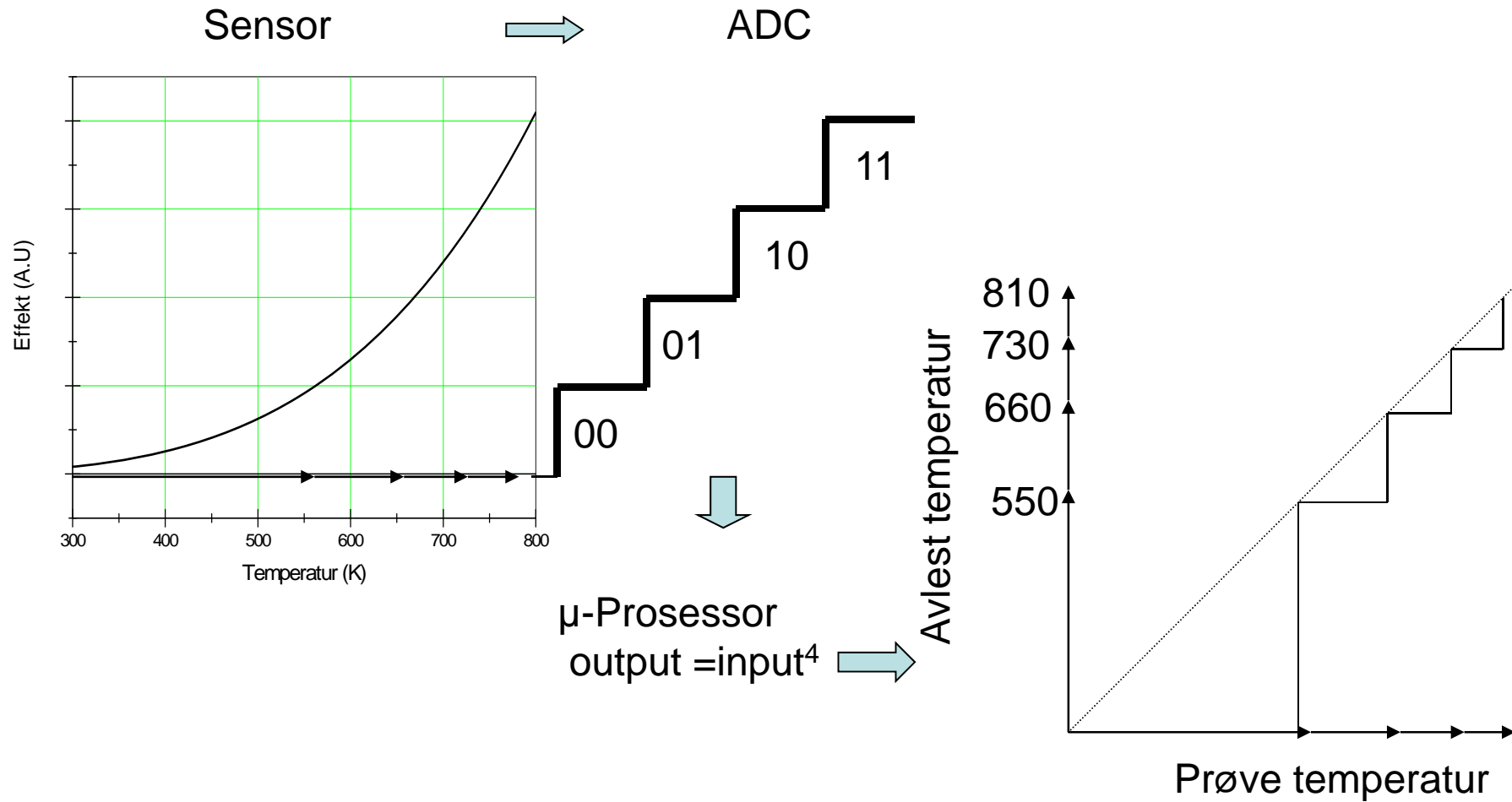

Utgangsimpedans

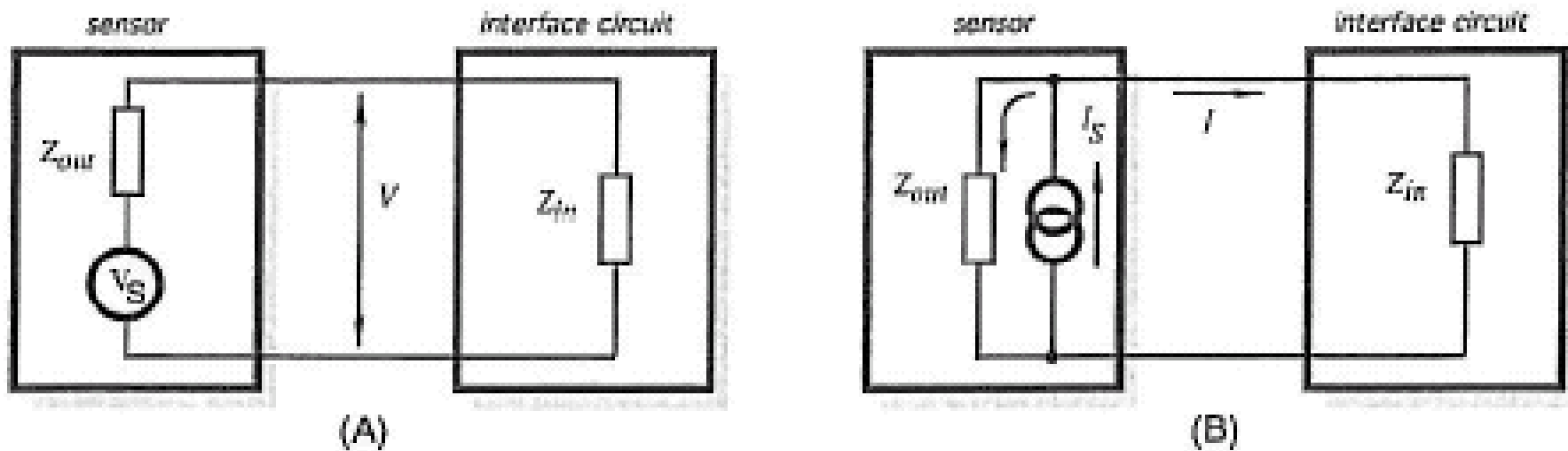

Fig. 2.8. Sensor connection to an interface circuit: (A) sensor has voltage output; (B) sensor has current output.