

Integrator

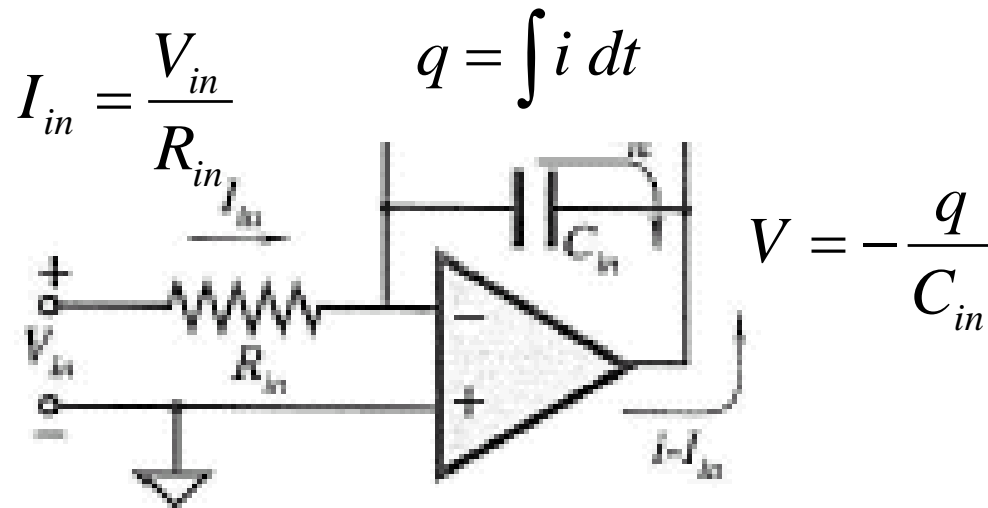

$$V_{out} = \int \frac{V_{in}}{R_{in} C_{in}} dt$$

Integrasjon og støy

Signal + 50 Hz støy

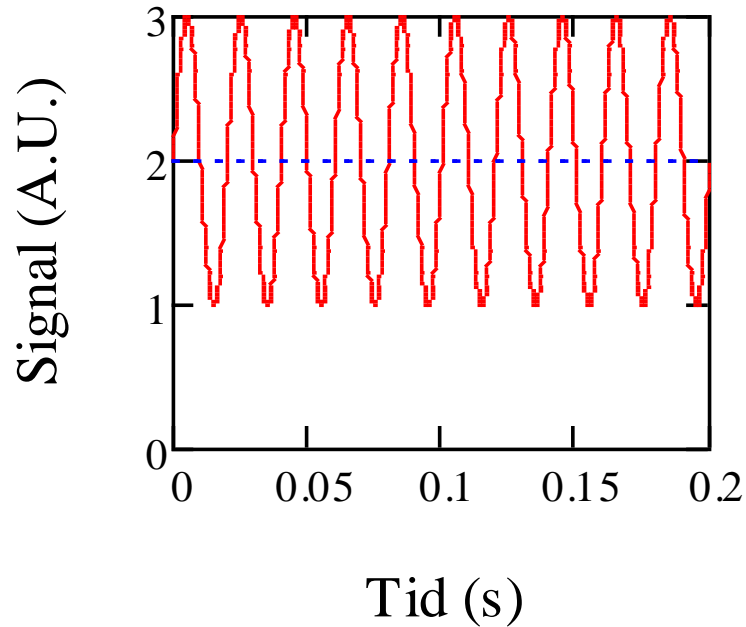

Signal + 60 Hz støy

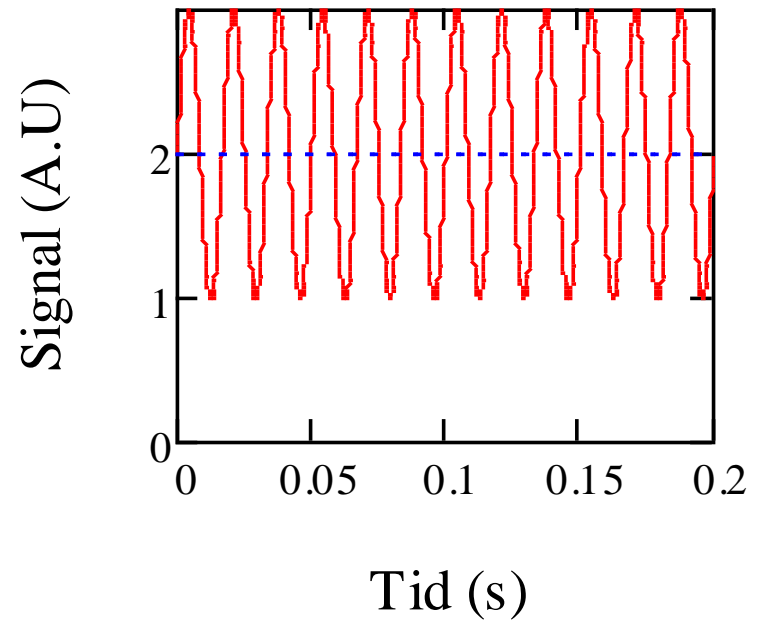

Filteregnskaper

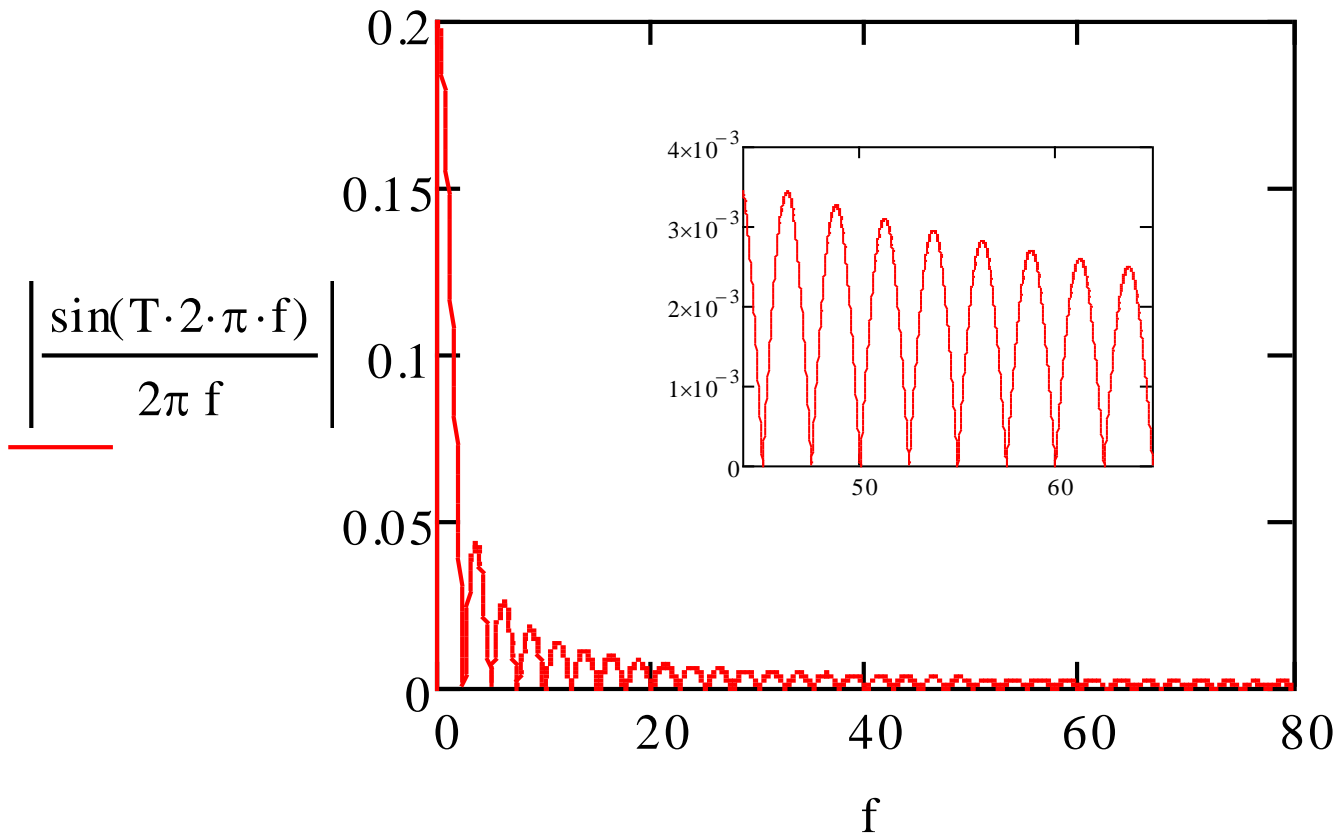

Dual-slope ADC

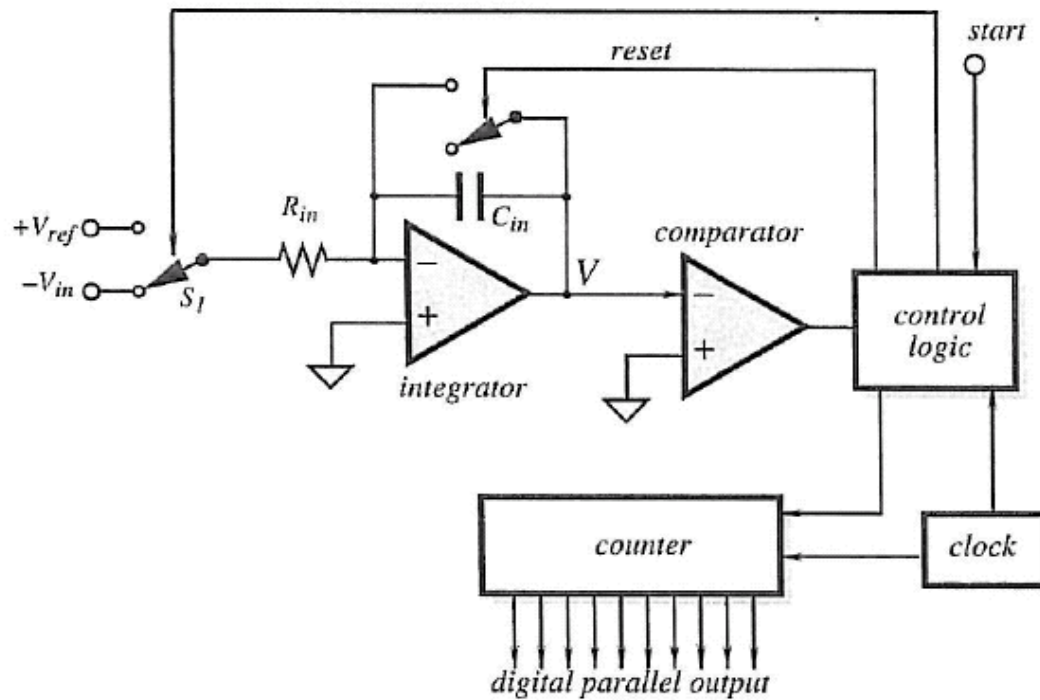

Fig. 5.27. Dual-slope A/D converter.

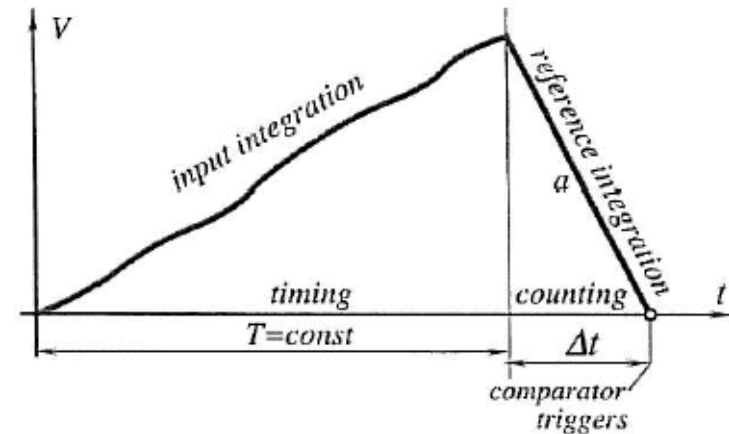

Fig. 5.28. Integrator output in a dual-slope A/D converter.

Spenning til frekvensomformer

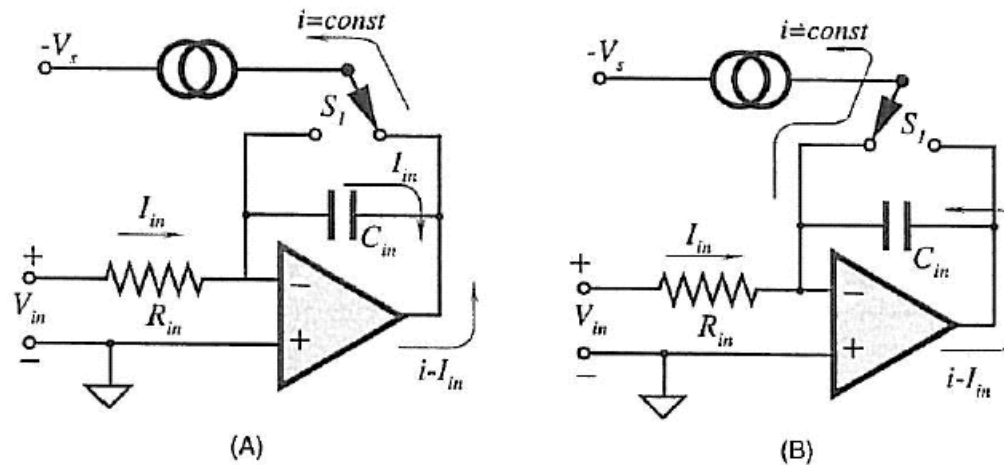

Fig. 5.25. Integrate and deintegrate (reset) phases in a charge-balance converter.

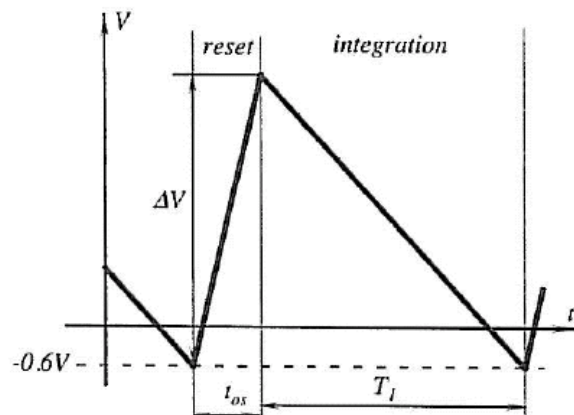
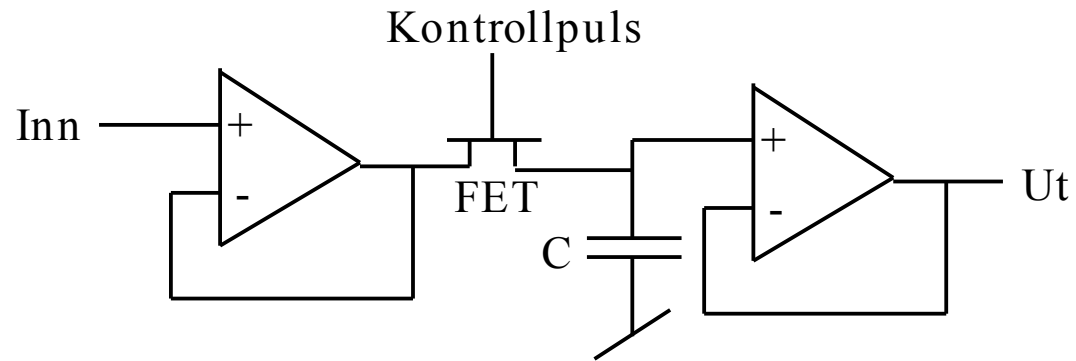

Fig. 5.26. Integrator output in a charge-balance converter.

$$f_{\text{out}} = \frac{1}{t_{\text{os}} + T_1} = \frac{I_{\text{in}}}{t_{\text{os}} i} = \frac{V_{\text{in}}}{R_{\text{in}}} \frac{1}{t_{\text{os}} i}$$

$$f_{\text{out}} = G V_{\text{in}}$$

Sample&Hold



Summasjon

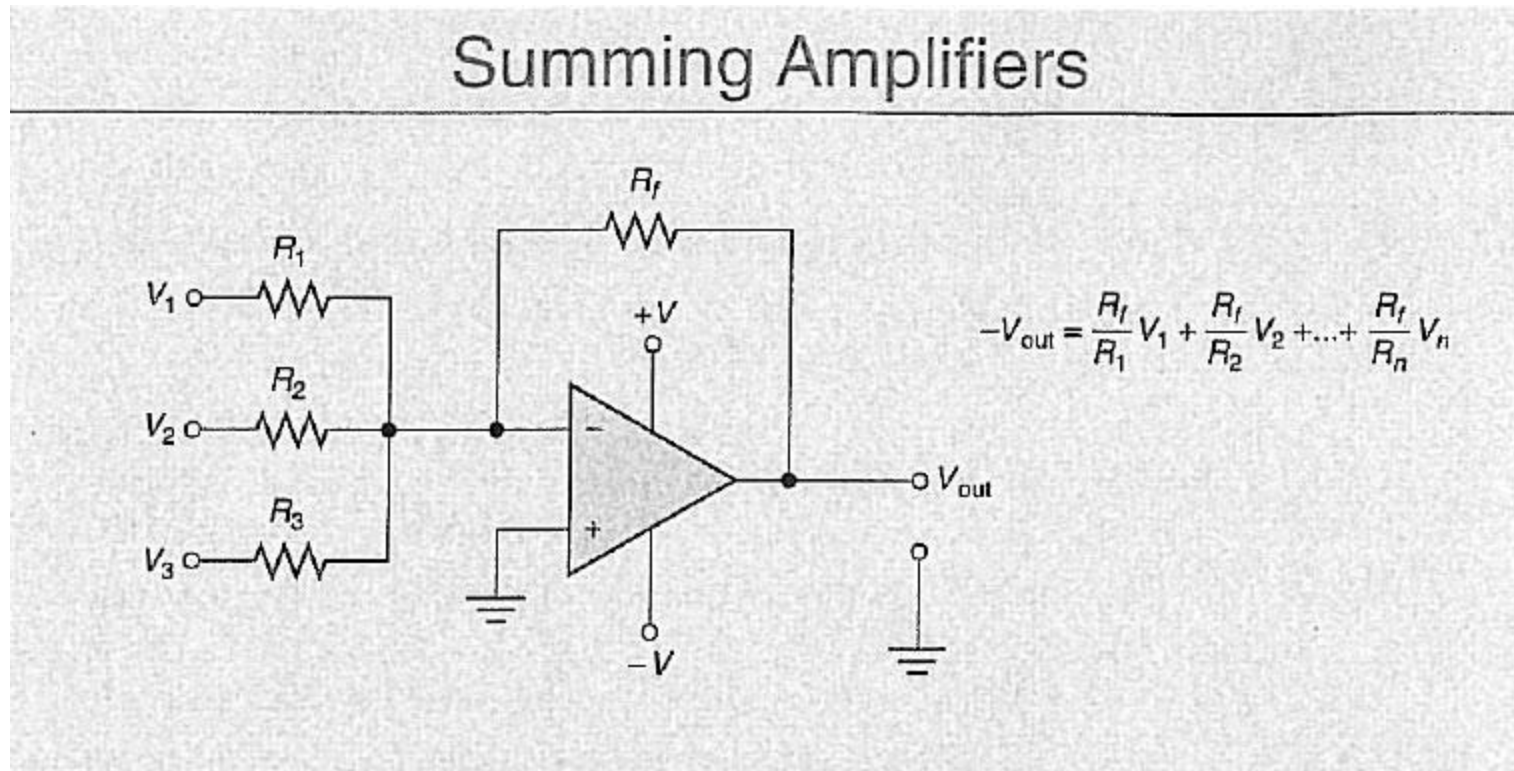

Paynter fig 22.43

Digital til Analog - binært nettverk

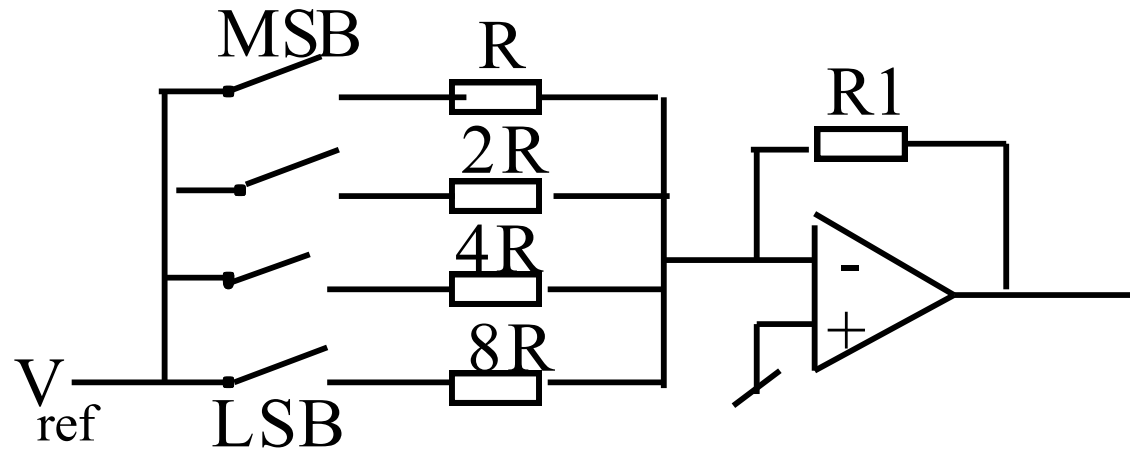

Digital til Analog R-2R

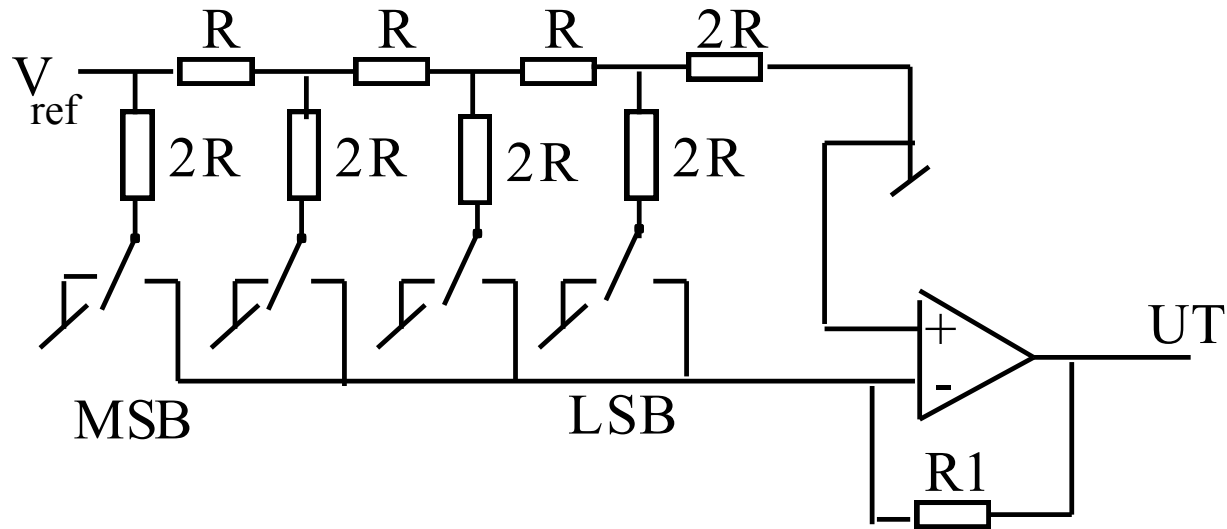

Kompendiet

Analog til Digital – Sukksessive Approksimasjoner

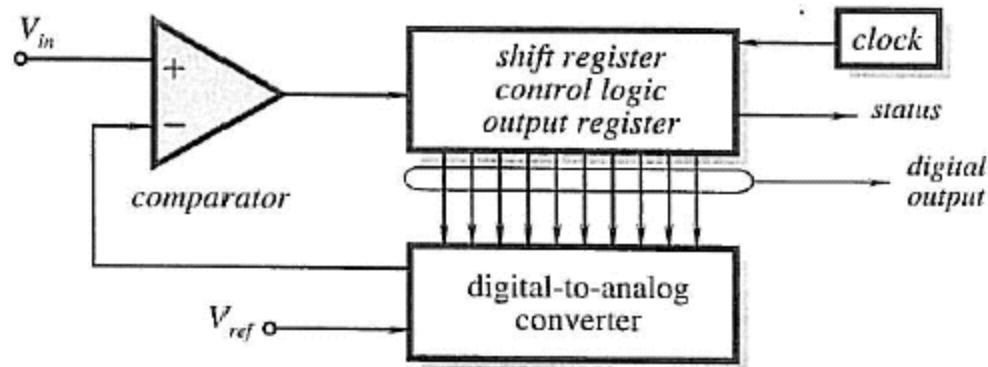

(A)

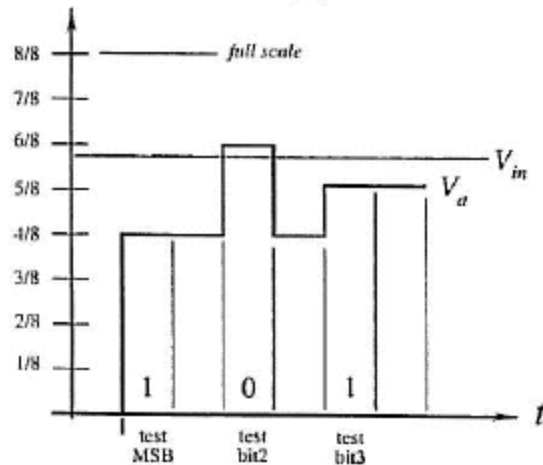

(B)

Fig. 5.29. Successive-approximation A/D converter: (A) block diagram; (B) 3-bit weighing.

Analog til Digital – Direkte (Flash)

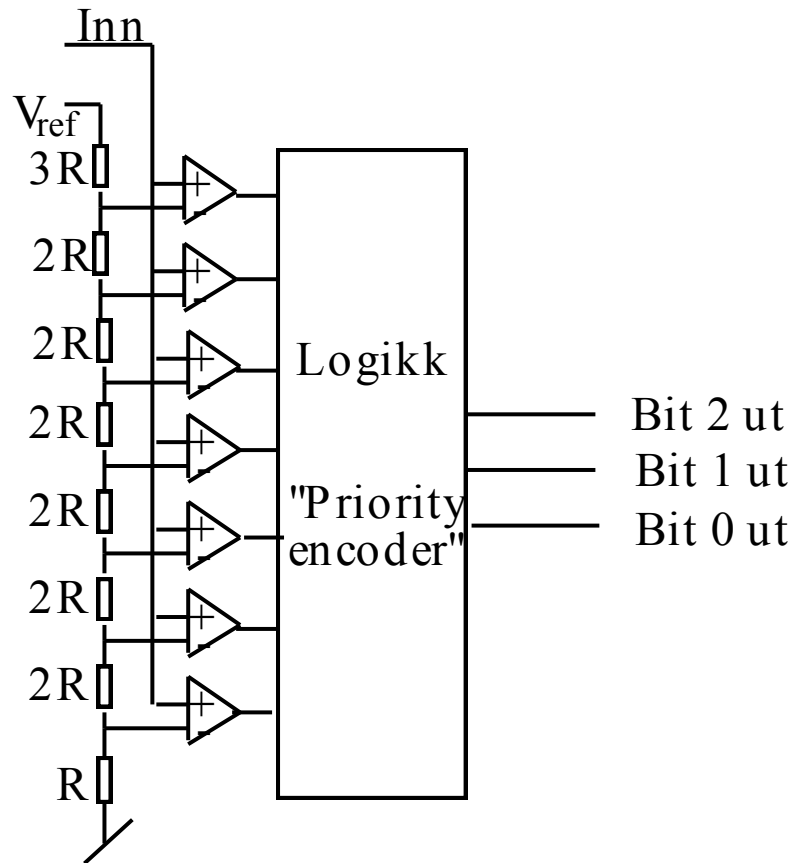

Sigma delta konverteren

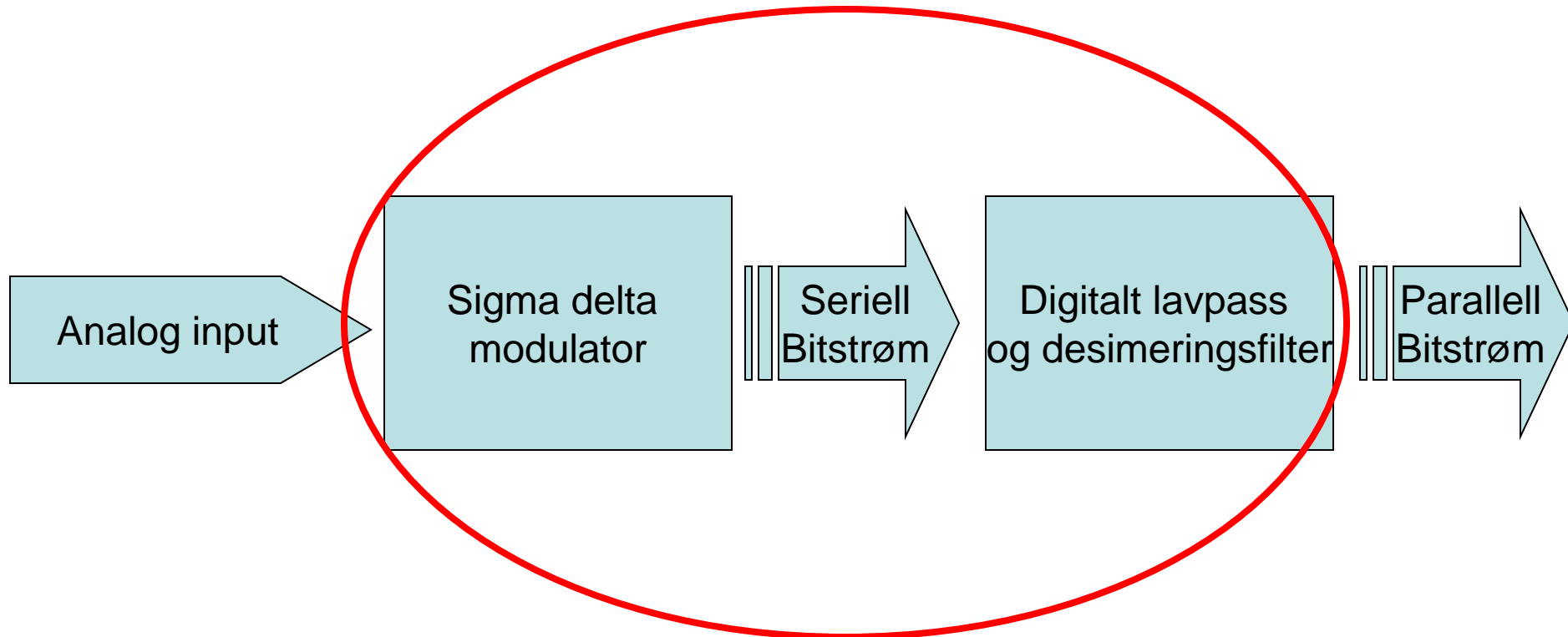

- Digitaliserer et analogt signal
- Består av en sigma delta modulator og et digitalt filter

Hva gjør sigma delta modulatoren?

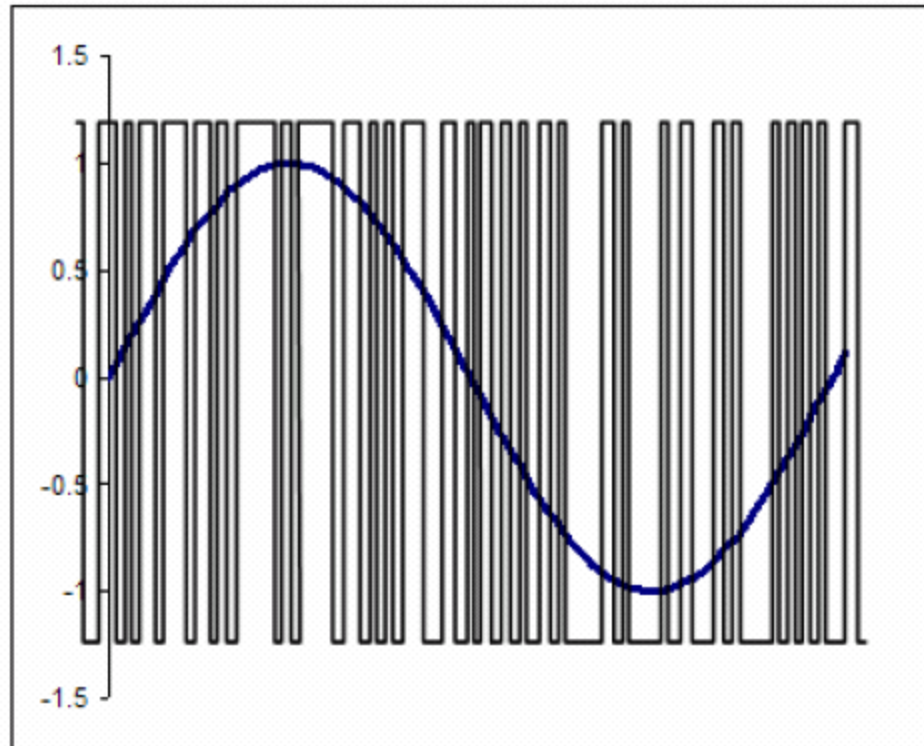

Figure 2 - $\Sigma\Delta$ modulator output representing sine-wave input

Gjør om et analogt signal til et digitalt signal der gjennomsnittet av det digitale signalet representerer det analoge signalet.

Hva gjør desimeringsfilteret

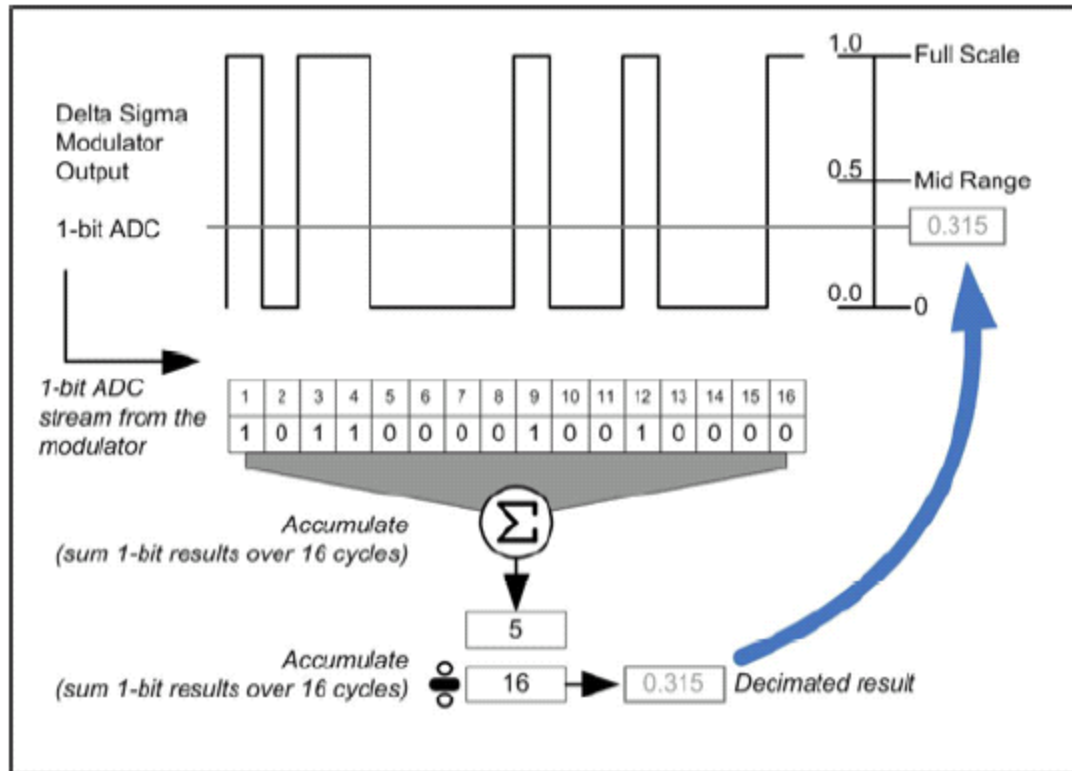
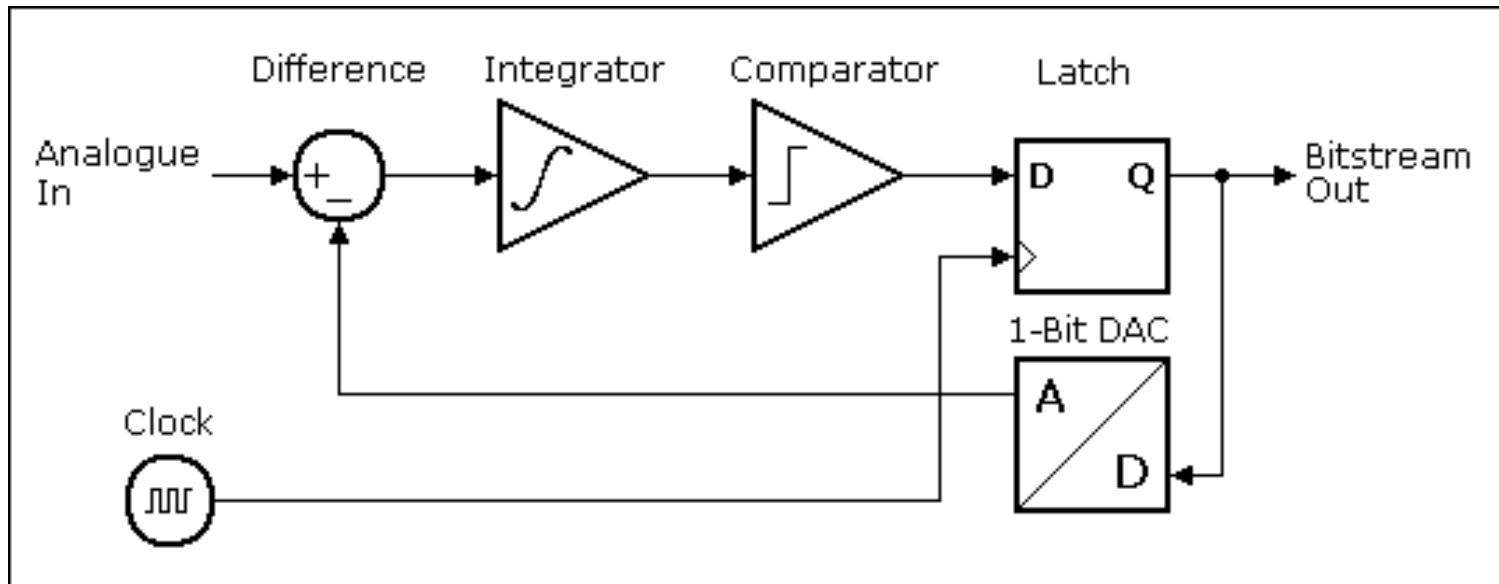
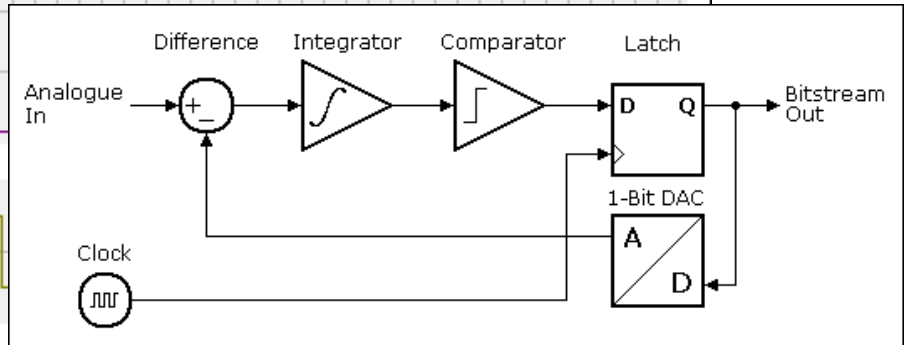
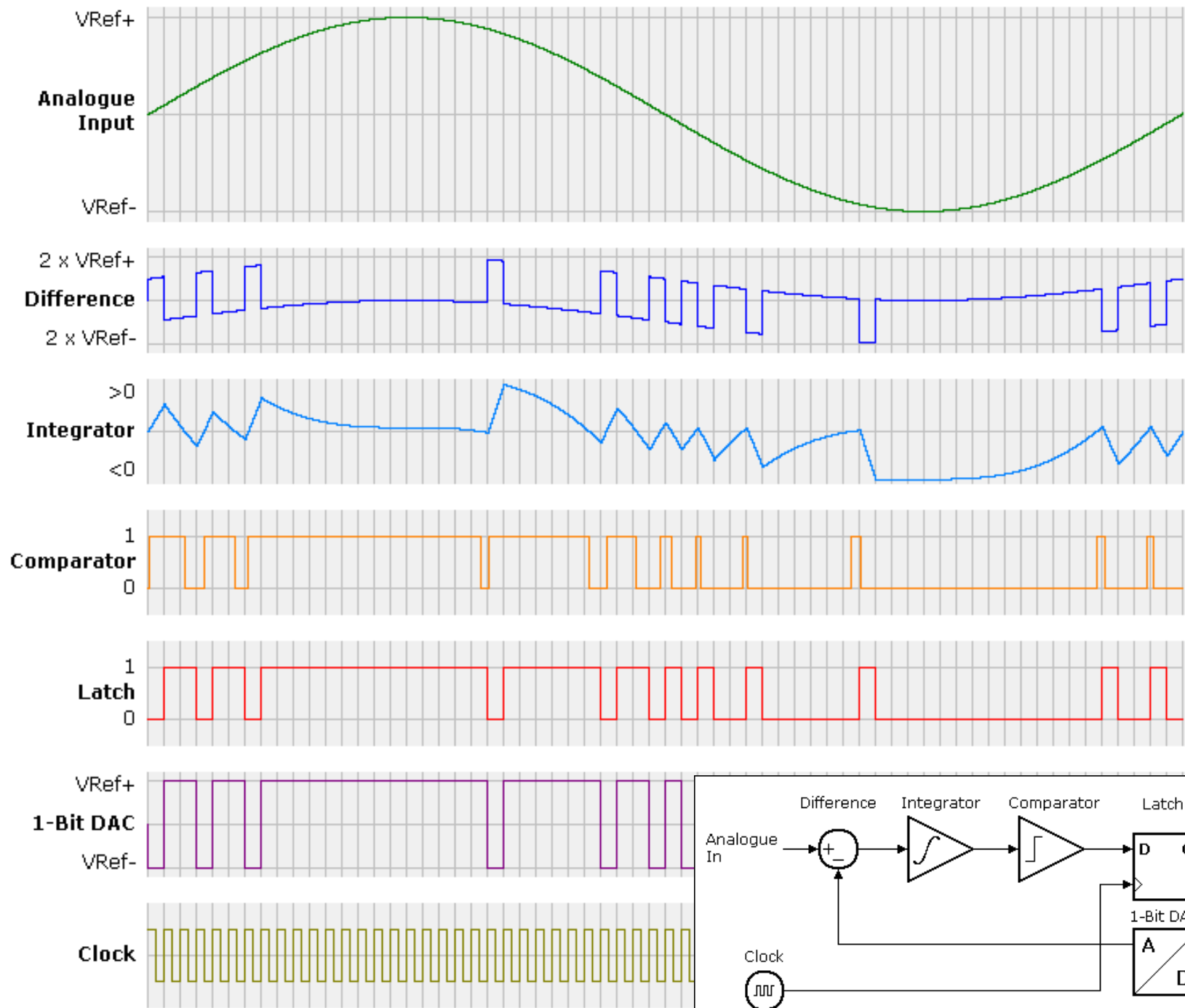

Figure 3 - $\Sigma\Delta$ A/D stream accumulated and decimated to represent an n-bit value of the input

Hvordan ser modulatoren ut?





Bruk av modulatoren alene

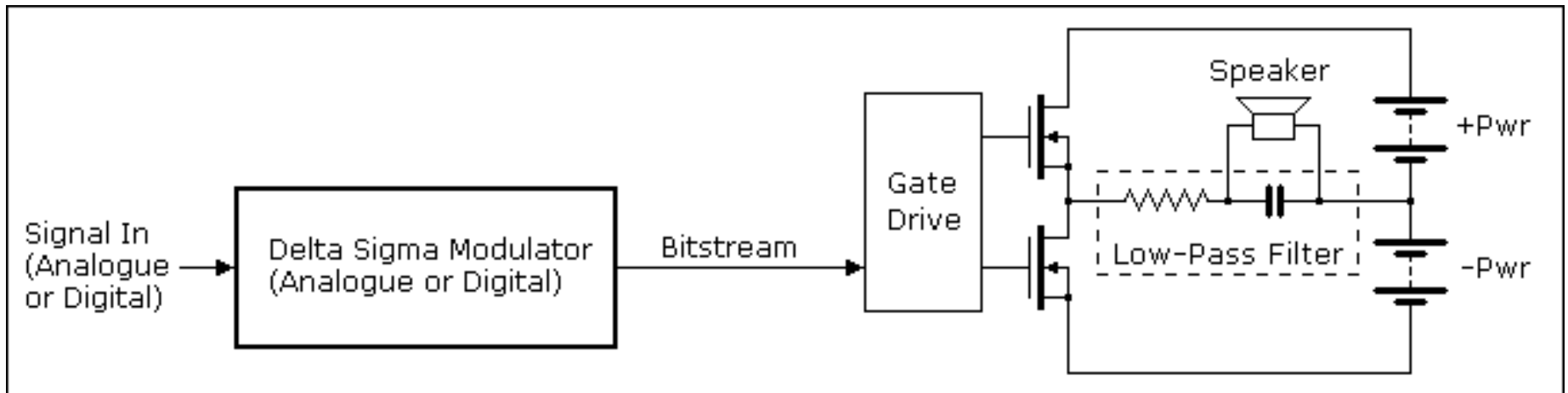
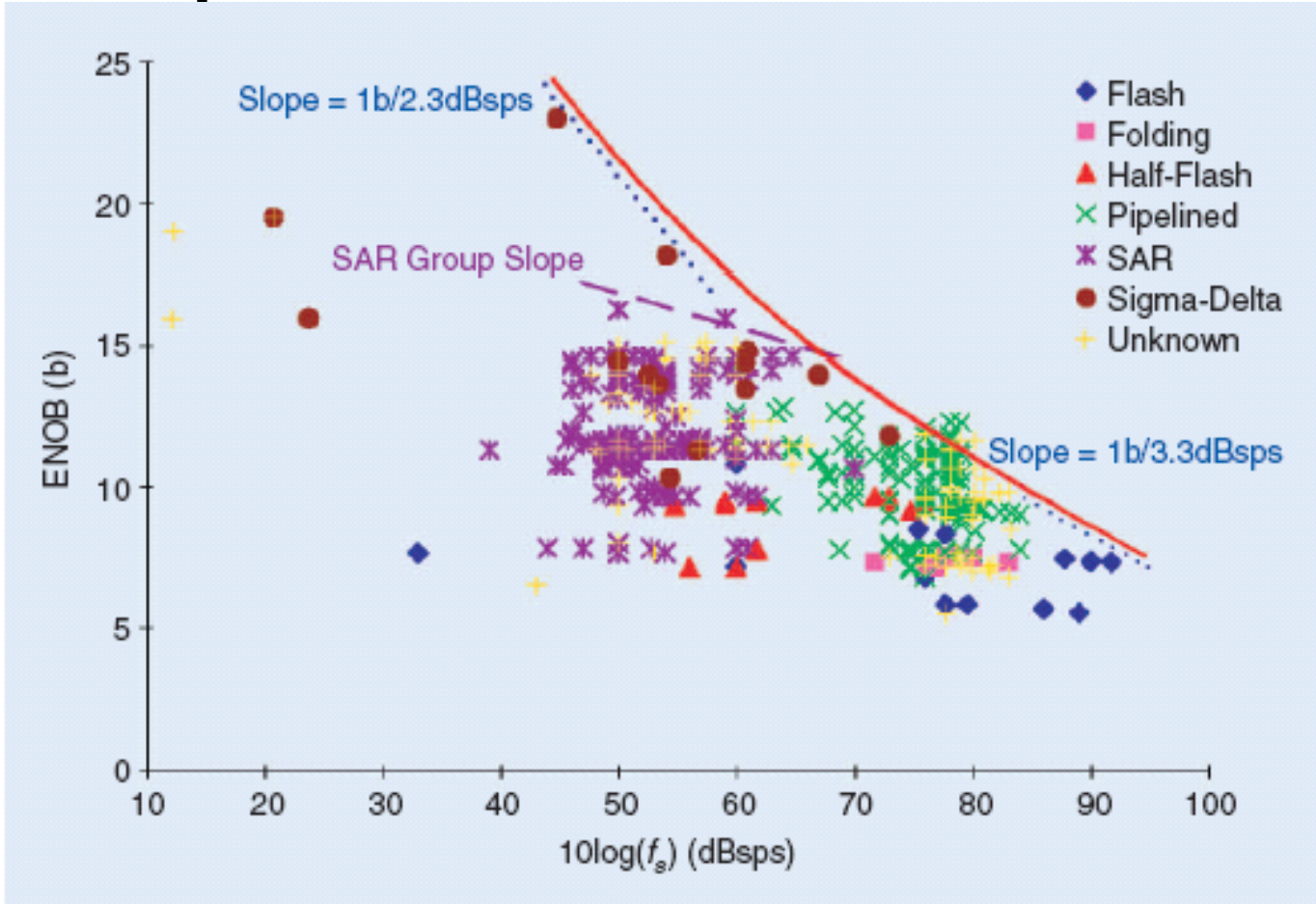

Figure 19 - Power Amplifiers using a Digital Output Stage (D-klasse)

Sample rate vs. effective bit



[FIG2] ENOB versus sampling rate.

Energiforbruk vs. hastighet

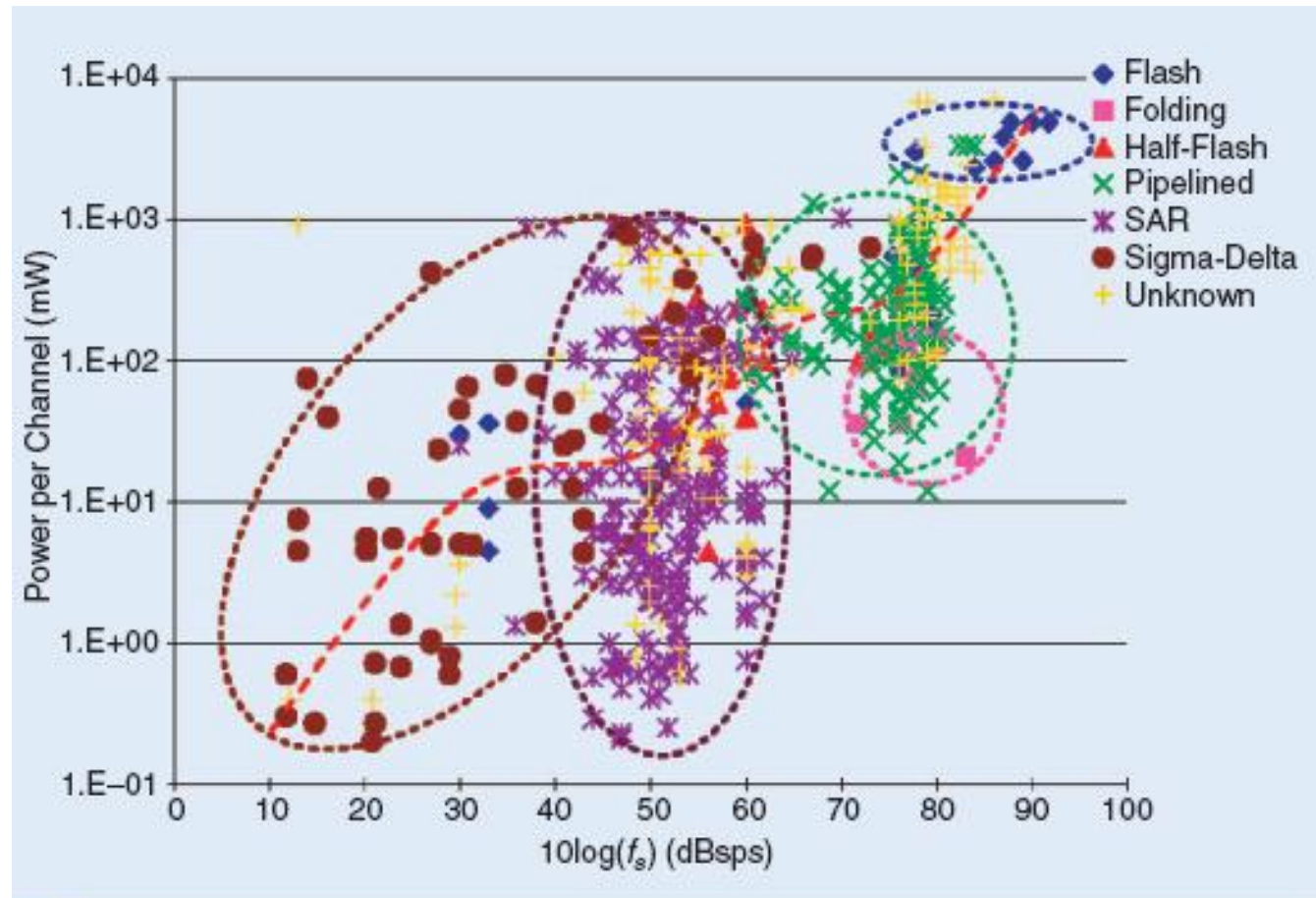

IG4] Power versus sampling rate.