

# Today's lecture

- Refresh basic mechanics
  - Angular momentum
  - Moment of inertia
  - Torque
- Gyros
  - Platforms/compass
  - Strap-down
- Inertial Measurement Units IMU

## Material from

- Hyperphysics  
<http://hyperphysics.phy-astr.gsu.edu/>
- Fraden Chapter 8
- Bosch/Sensoror
- **Advances in Navigation Sensors and Integration Technology** [www.rta.nato.int](http://www.rta.nato.int)
- Handbook of Virtual Environment Technology
- InvenSense

# Dreie impuls

## Angular Momentum of a Particle

The angular momentum is the same at every point on an orbit. When it is closer, it increases speed.

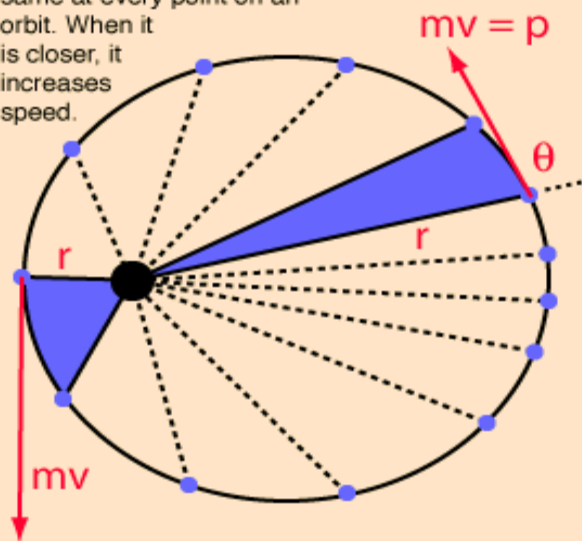

The angular momentum of a particle of mass  $m$  with respect to a chosen origin is given by

$$L = mvr \sin \theta$$

or more formally by the vector product

$$L = r \times p$$

The direction is given by the right hand rule which would give  $L$  the direction out of the diagram. For an orbit, angular momentum is conserved, and this leads to one of Kepler's laws. For a circular orbit,  $L$  becomes

$$L = mvr$$

# Dreie impuls og treghetsmoment

## Moment of Inertia, General Form

Since the moment of inertia of an ordinary object involves a continuous distribution of mass at a continually varying distance from any rotation axis, the calculation of moments of inertia generally involves calculus, the discipline of mathematics which can handle such continuous variables. Since the moment of inertia of a [point mass](#) is defined by

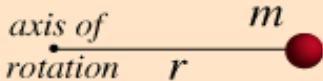
$$I = mr^2$$

The diagram shows a horizontal line representing the axis of rotation. A red dot representing a point mass  $m$  is located at a distance  $r$  from the axis. The text "axis of rotation" is written below the axis line.

then the moment of inertia contribution by an infinitesimal mass element  $dm$  has the same form. This kind of mass element is called a [differential element](#) of mass and its moment of inertia is given by

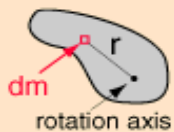

$$dI = r^2 dm$$

The "d" preceding any quantity denotes a vanishingly small or "differential" amount of it.

Note that the differential element of moment of inertia  $dI$  must always be defined with respect to a specific rotation axis. The sum over all these mass elements is called an [integral](#) over the mass.

$$I = \int dI = \int_0^M r^2 dm$$

## Angular Momentum

The angular momentum of a rigid object is defined as the product of the [moment of inertia](#) and the [angular velocity](#). It is analogous to [linear momentum](#) and is subject to the fundamental constraints of the [conservation of angular momentum](#) principle if there is no external [torque](#) on the object. Angular momentum is a [vector quantity](#). It is derivable from the expression for the [angular momentum of a particle](#)

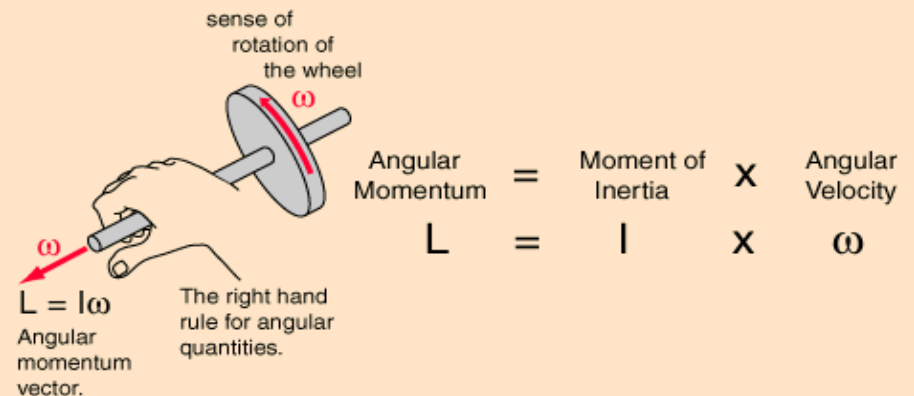

[Comparison of linear and angular momentum](#)

# (Kraft-) moment

## Torque

A torque is an influence which tends to change the rotational motion of an object.  
One way to quantify a torque is

$$\text{Torque} = \text{Force applied} \times \text{lever arm}$$

The lever arm is defined as the perpendicular distance from the axis of rotation to the line of action of the force.

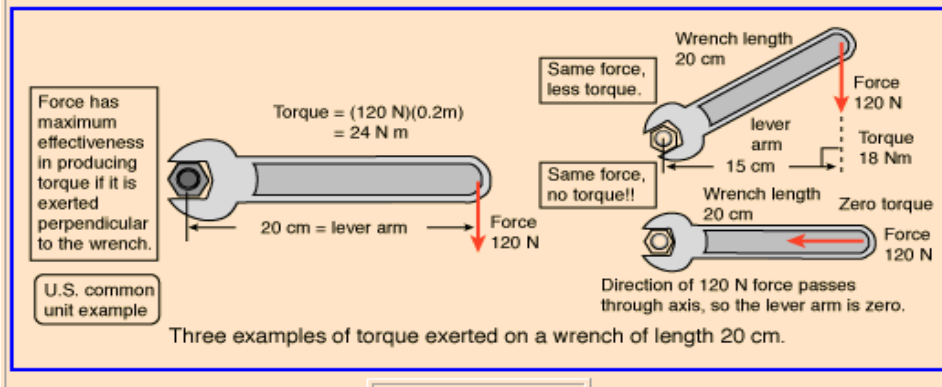

## Right Hand Rule for Torque

**Torque** is inherently a **vector quantity**. Part of the torque calculation is the determination of direction. The direction is perpendicular to both the radius from the axis and to the force. It is conventional to choose it in the right hand rule direction along the axis of rotation. The torque is in the direction of the **angular velocity** which would be produced by it in the absence of other influences. In general, the **change in angular velocity** is in the direction of the torque.

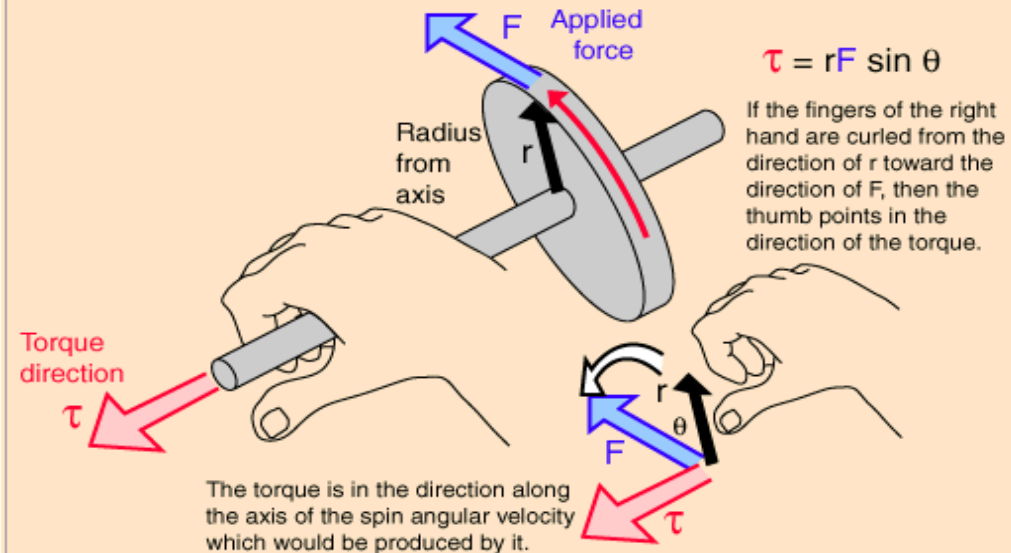

# Mekaniske gyro prinsipper

Gyro kompass  
(Gyro stabilized platform)

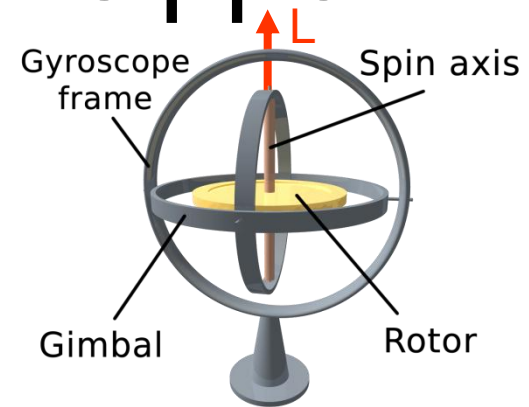

$$\frac{d\vec{L}}{dt} = \vec{\tau} = 0$$

Måles

Følger "bilen"

Rate gyro  
(Strap-down gyro)

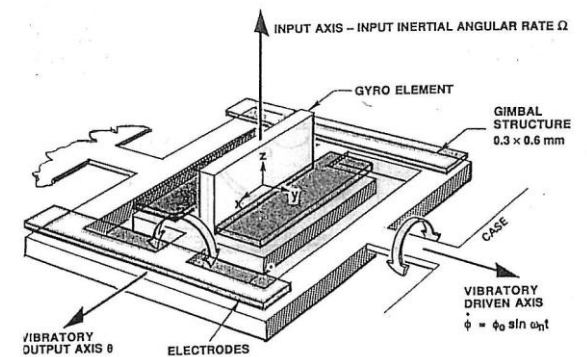
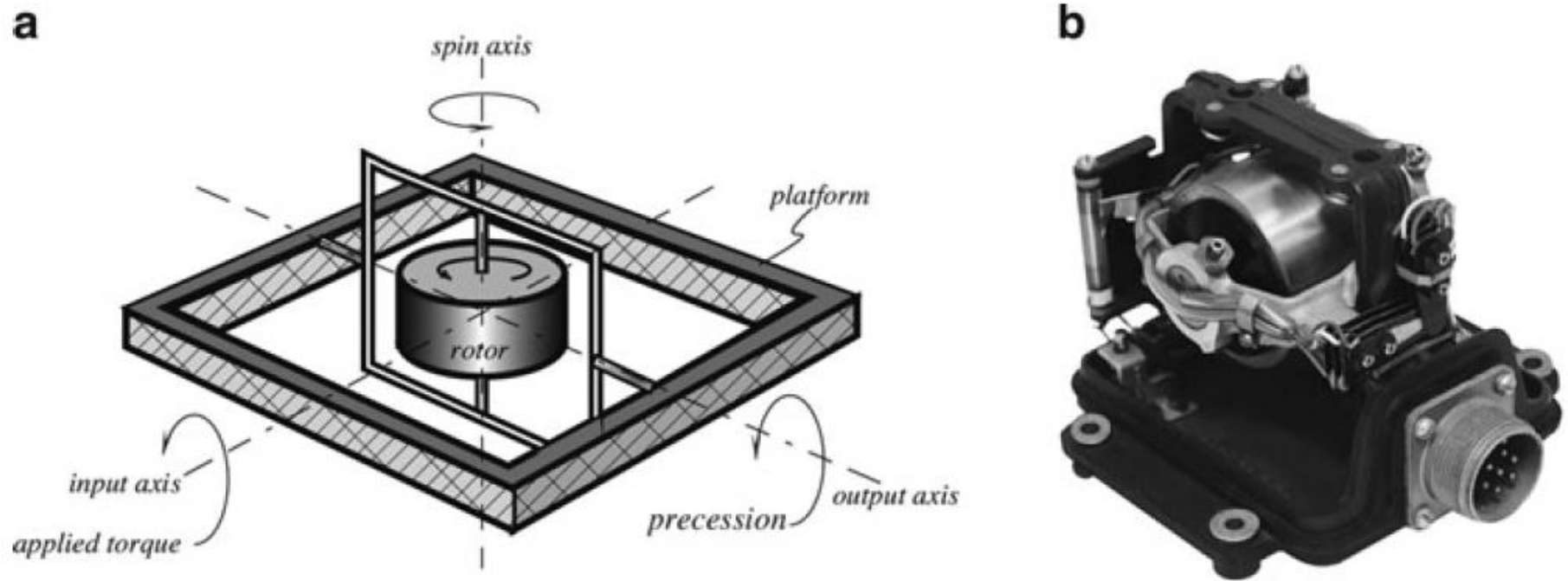

Fig. 8.12. Vibratory rate gyro concept. (From Ref. [7].)

# Gyro compass

340

8 Velocity and Acceleration



**Fig. 8.10** Mechanical gyroscope with a single degree-of-freedom (a) and early auto-pilot gyroscope (b)

# Bosch strap down gyro

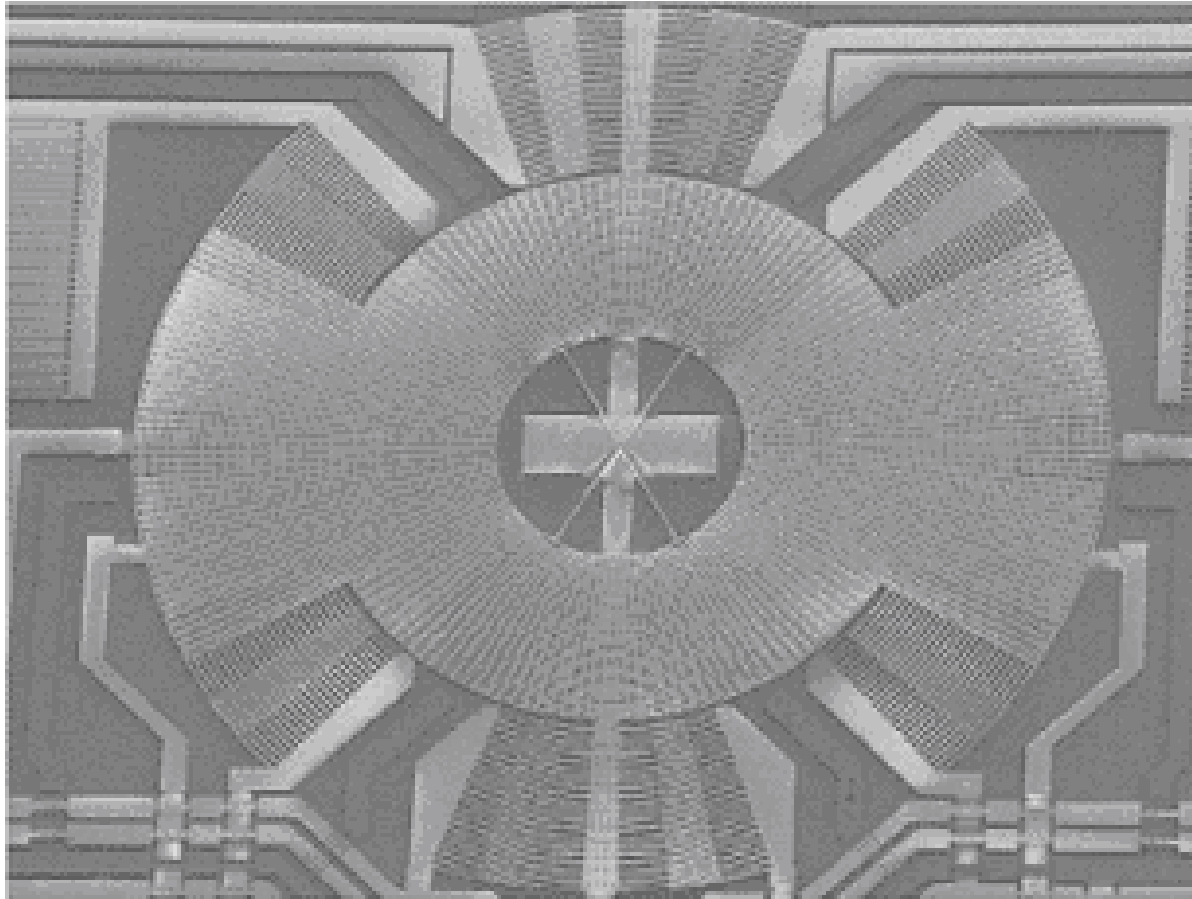



# Automotive rate gyro (strap down)

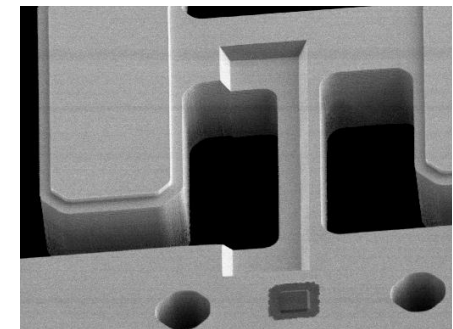
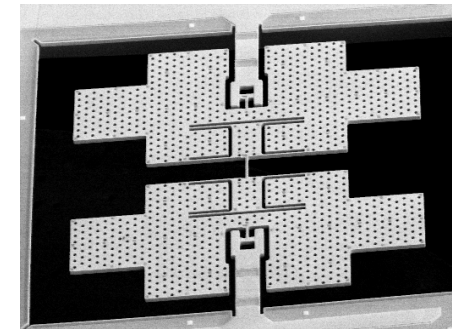
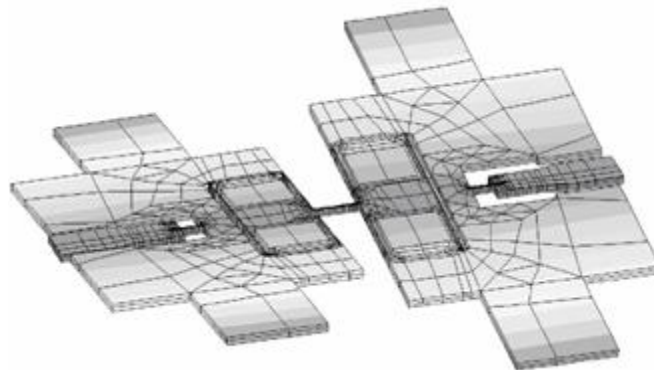
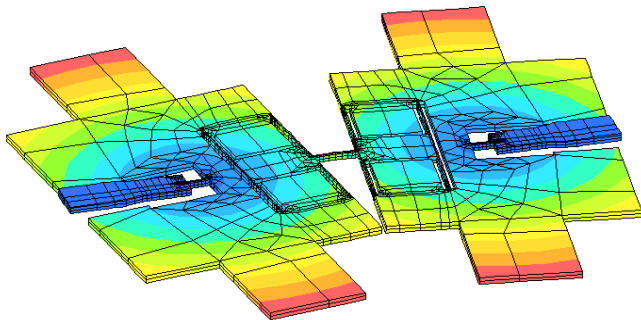
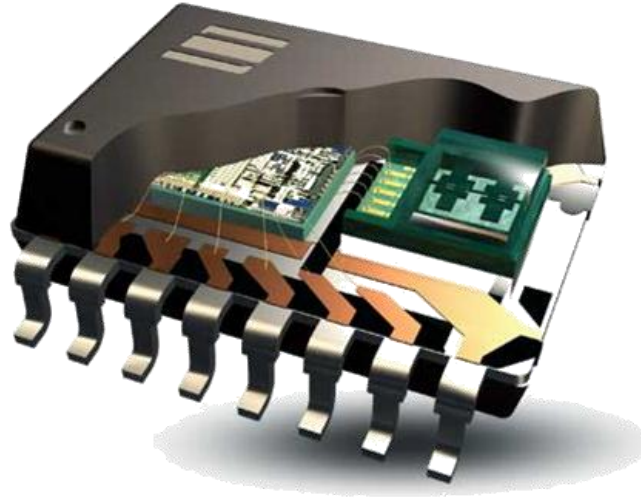

Sensor SAR 10



# Fiber optic ring gyro

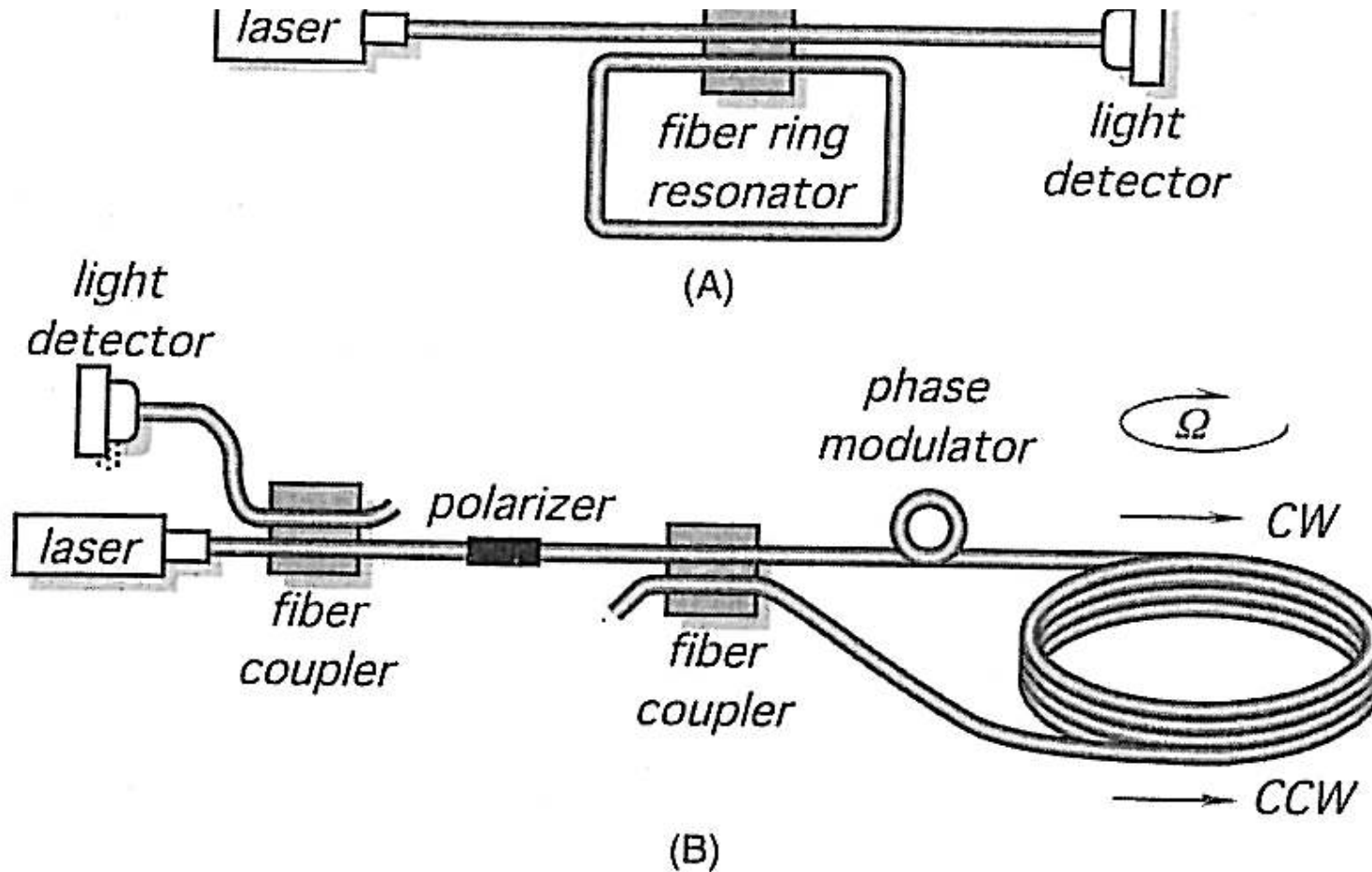

8.14. (A) Fiber-optic ring resonator; (B) fiber-optic analog coil gyro. (Adapted from [9].)

# IMU-INS

- Inertial measurement unit (IMU)
- Inertial navigation system (INS)

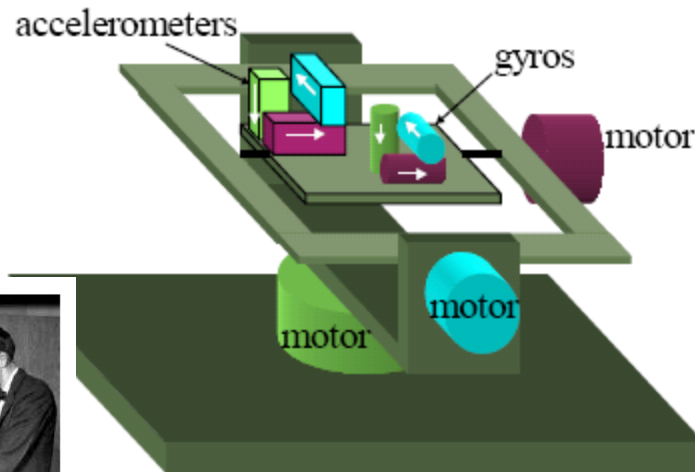

Figure 2a : Stable-platform INS

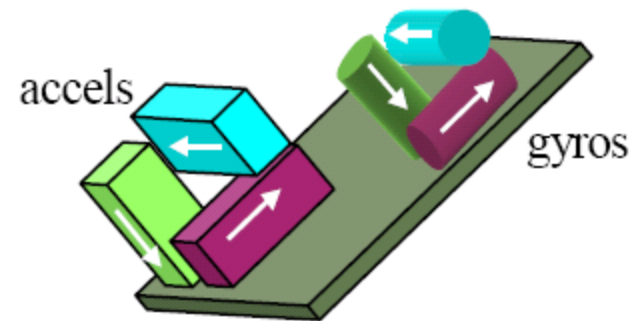

Figure 2b: Strapdown IMU



Figure 1. SPIRE system.



# Militære anvendelser og krav

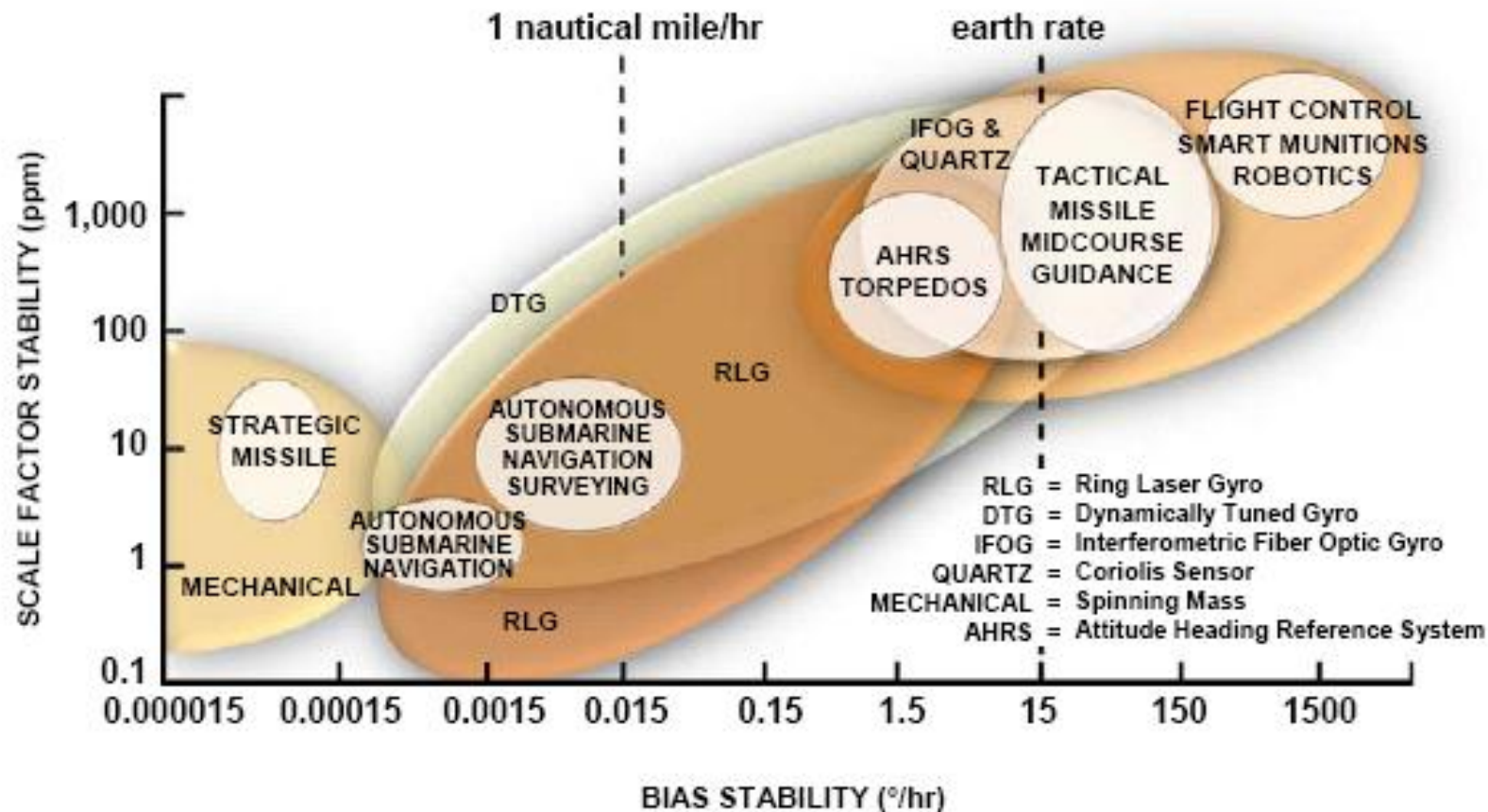

Figure 3. Current gyro technology applications.

	Commercial-Grade	Tactical-grade	Navigation-grade	Strategic-grade	Geophysical limit
Gyro bias stability	1500°/hr/√hr	15°/hr/√hr	0.015°/hr/√hr	0.000015°/hr/√hr	0°/hr/√hr
Gyro bias initial uncertainty	150°/hr	1.5°/hr	0.0015°/hr	0.0000015°/hr	0°/hr
Accel bias stability	1 mg/√hr	100 μg/√hr	10 μg/√hr	0.5 μg/√hr	0 μg/√hr
Accel bias initial uncertainty	0.25 mg	10 μg	1 μg	0.1 μg	0.1 μg
Initial orientation alignment	1 arcsecond	1 arcsecond	1 arcsecond	0.1 μrad	0.01 μrad

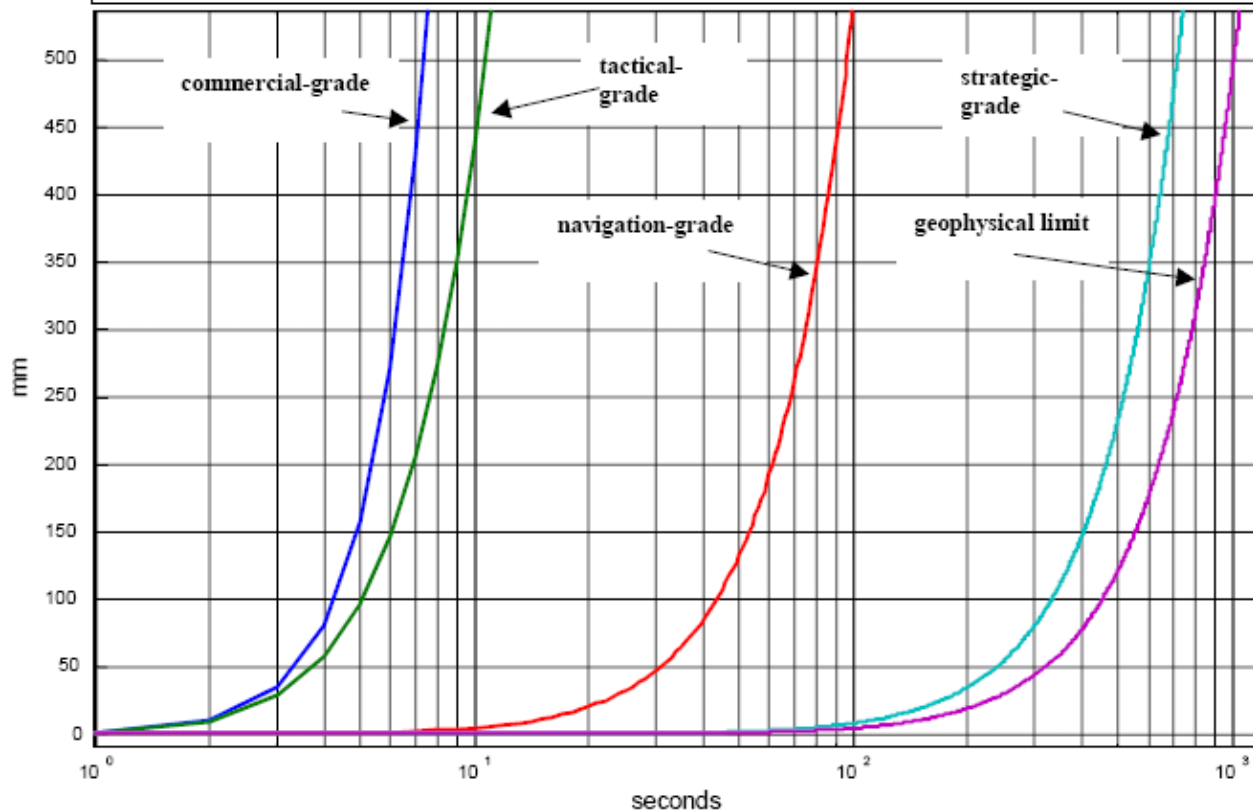

Figure 4: Comparison of 1- $\sigma$  random position drift performance of commercial, tactical, navigation, strategic-grade, and “perfect” inertial navigation systems over a 20 minute covariance simulation.

# Teknologiske trender (2003)

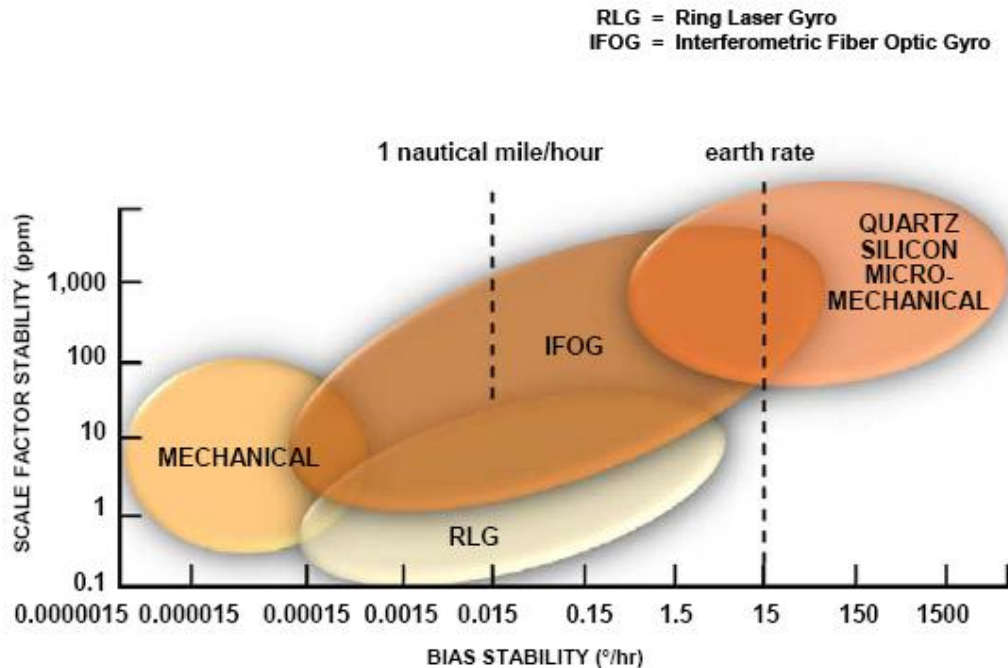

Figure 4. Near-term gyro technology applications.

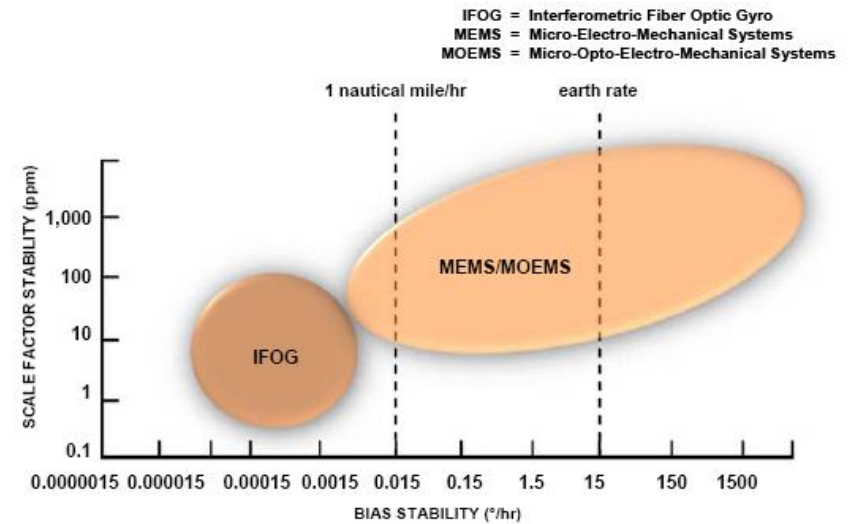

Figure 5. Far-term gyro technology applications.

# Akselerometere (2003)

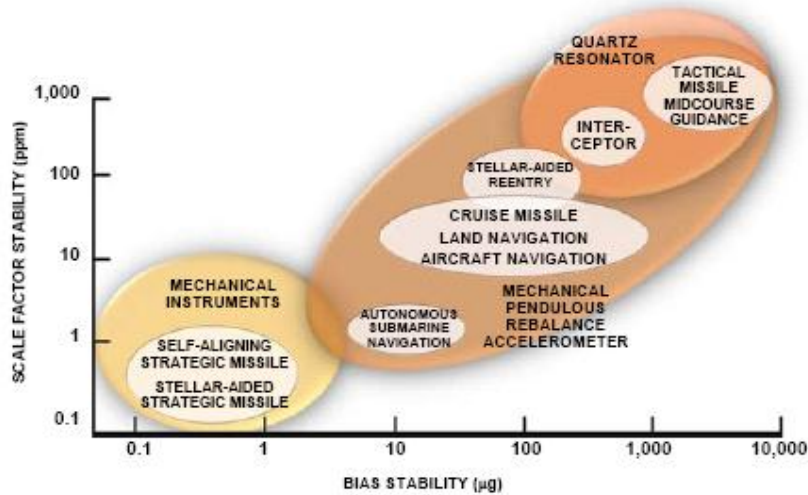

Figure 6. Current accelerometer technology applications.

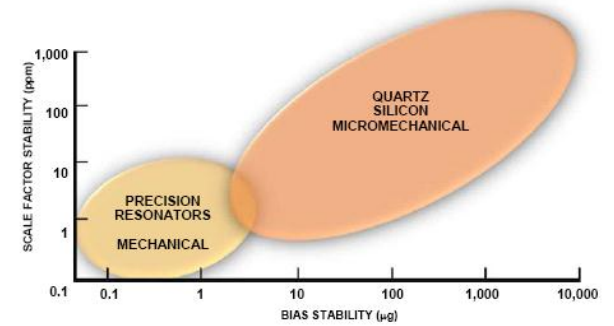

Figure 7. Near-term accelerometer technology applications.

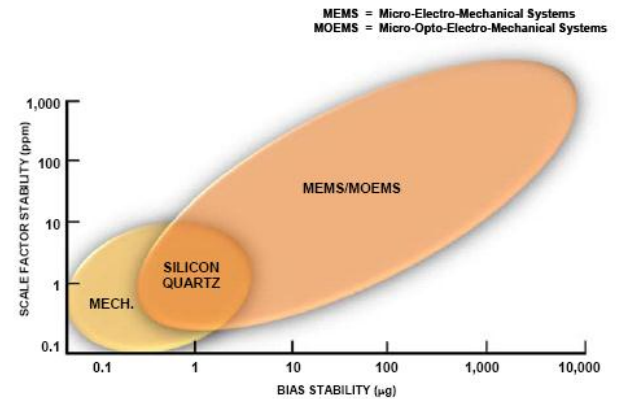

Figure 8. Far-term accelerometer technology applications.



# Kostnadsbildet

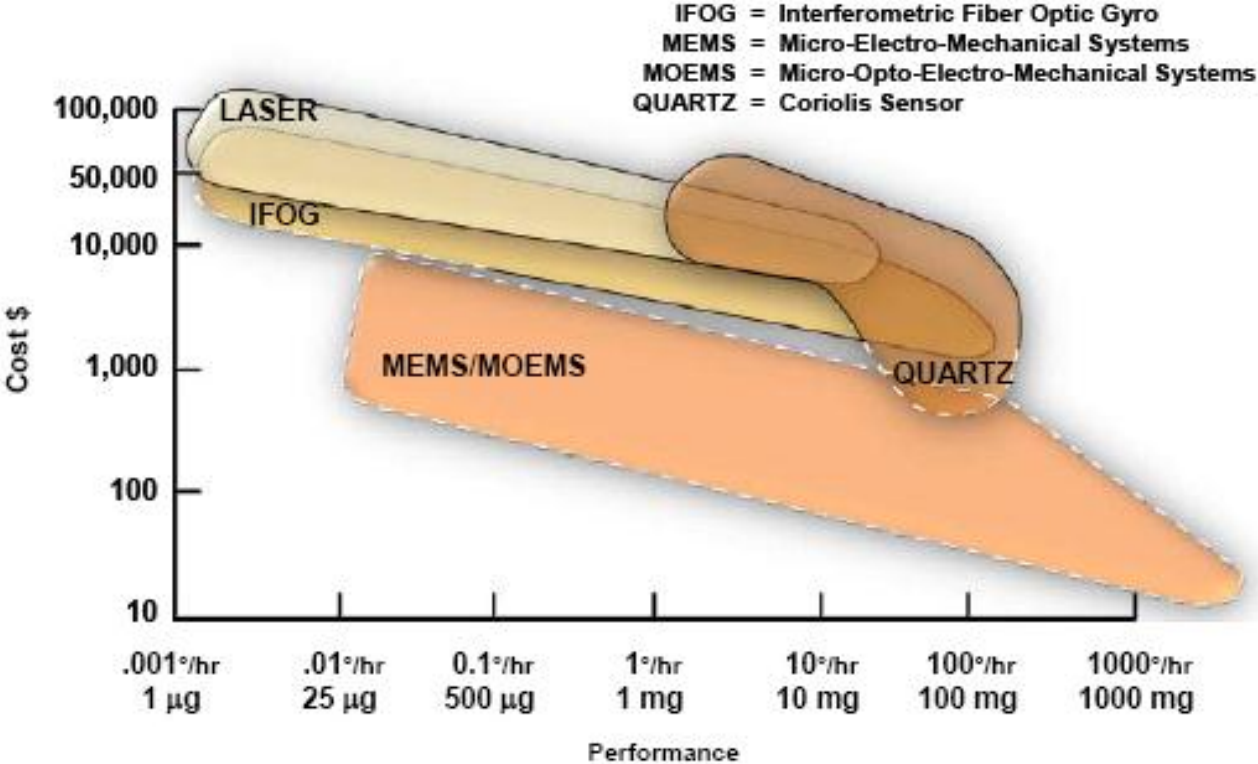

Figure 9. INS cost as a function of instrument technology.



# Teknologiforventninger (2003)

Very Precise Navigation	Long-Range Guidance	1 nm/hr Navigator	Tactical Weapons	Commercial Consumer
<i>Accelerometer Technology</i>				
Cold Atom	Cold Atom	MEMS	MEMS	MEMS NEMS
Mechanical	MEMS Mechanical			
<i>Gyro Technology</i>				
Cold Atom	Cold Atom	IOG	MEMS	MEMS NEMS
	IFOG			
IFOG	HRG	PCF FOG	MEMS	MEMS NEMS
	IOG			

Figure 18: Future Applications for Inertial Sensor Technology.

# Smart phone IMU

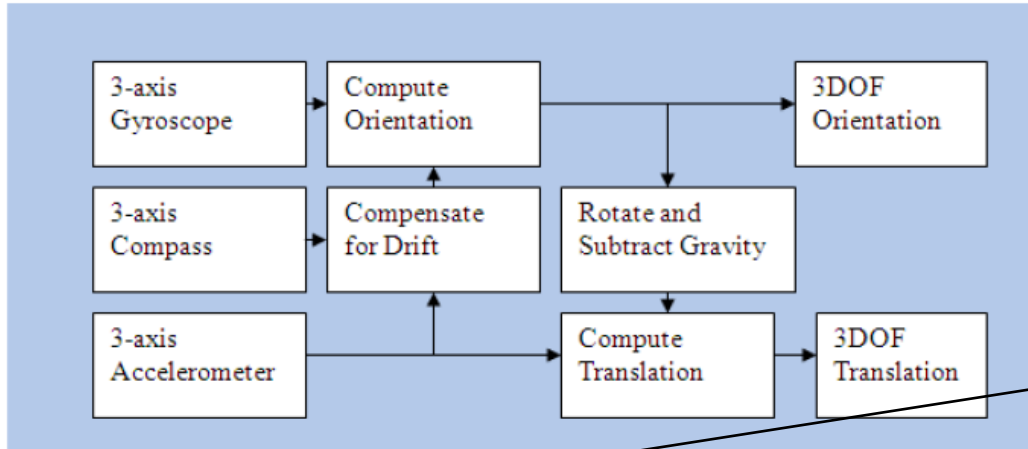

+ Trykk ←

Figure 9. 9-axis sensor fusion algorithm. Information from gyroscope, accelerometer, and digital compass are integrated to generate 6 degrees-of-freedom (DOF) motion information (3-axis orientation and 3-axis translation).

