

UNIVERSITY OF OSLO

Faculty of Mathematics and Natural Sciences

Exam in : FYS 3240/4240
Day of exam: : 10. June 2013
Exam hours: : 09.00 – 12.00
This examination paper consists of 2 pages.

Permitted materials: : **Calculator**

Make sure that your copy of this examination paper is complete before answering.

Problem 1

- a) Explain how memories are used when data are transferred from a DAQ-card and into the DAQ software program. The DAQ-card is assumed to be configured for continuous sampling.
- b) Explain overwrite and overflow errors when reading from a DAQ-card.
- c) How can the errors in problem 1b) be avoided?
- d) Given that a 100 Hz sinus signal is sampled by a DAQ-card with a sample frequency of 50 kHz, and the buffer size of the DAQ-card is 1000 samples. If you plot the 1000 samples in a graph, how many periods of the 100 Hz signal do you see?
- e) Explain the term oversampling, and why it is useful in data acquisition.

Problem 2

- a) Explain the differences between software timing and hardware timing, and give examples of how both timing techniques can be used in a software program for data acquisition.
- b) Given a clock with an error of 20 ppm (0.002 %), what is the accumulated clock error during one day (24 hours)?
- c) What is the typical accuracy of the following time synchronization technologies: GPS, IEEE-1588, IRIG-B, NTP and TCP/IP?
- d) What is a leap second, and why is it used?

Problem 3

- Explain RAID-0 and RAID-5.
- Why is it a limit of about 2.2 TB in disk size for Windows XP 32 bit?
- Explain the new standard in use to avoid the limitation in problem 3b).
- Explain the term “Hardware acceleration”, and give two examples of how it can be used.
- What is the problem(s) with the LabVIEW code in *Figure 1* ?

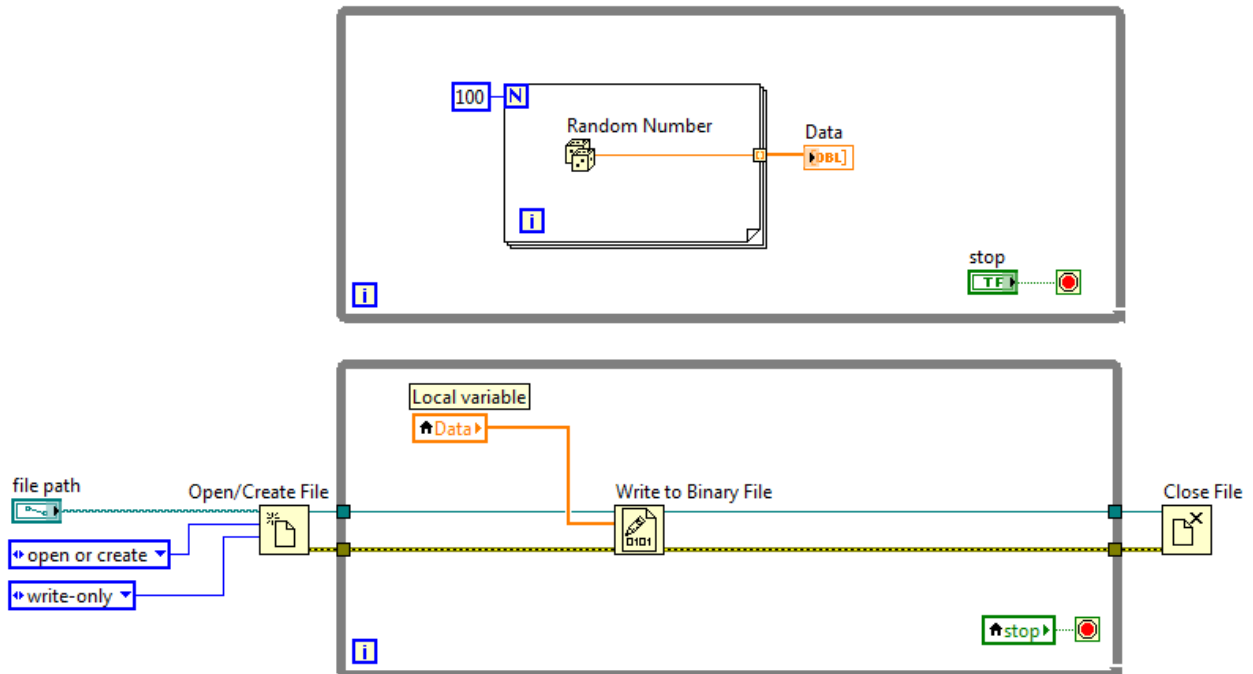

Figure 1: LabVIEW code for problem 3 e)