

BATT IN 3.7V

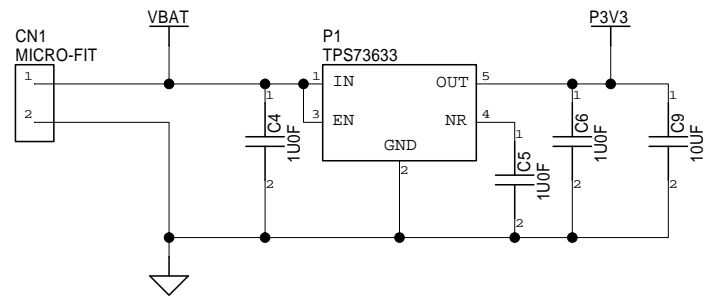

USB -> UART

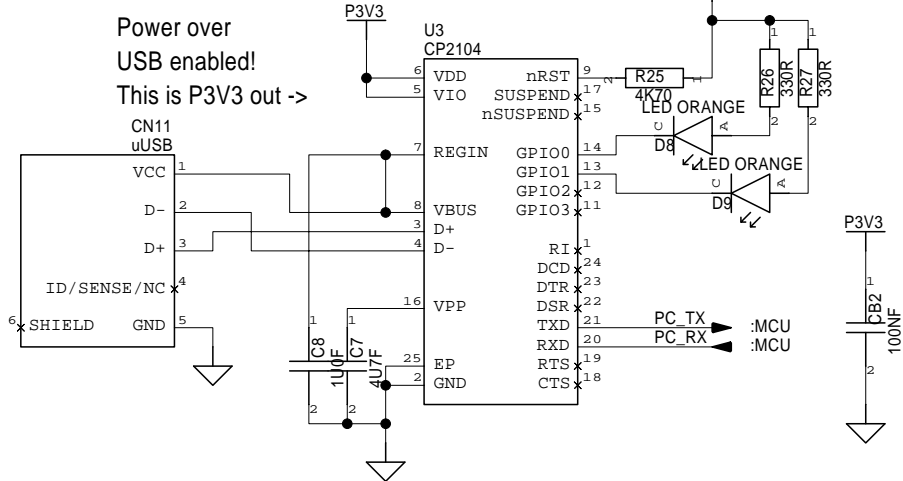

Power over USB enabled!
This is P3V3 out ->

Motor/LED Out

MCU

MotionSense

4x MOTOR OUT

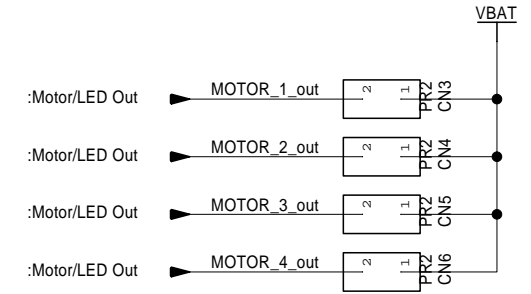

RC Input

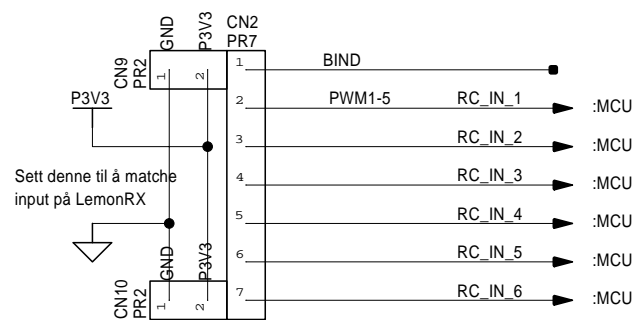

VBAT - Battery connection. LDO to P3V3, directly connected to motors, buzzer and battery monitoring. These functions will not work when powered from other sources.
P5V0 - External power when battery is not connected, LDO to P3V3 to power the board but doesn't power motors or other things directly connected to VBAT.
P3V3 - Digital and Analog power for the rest of the board and powers the PWM receiver

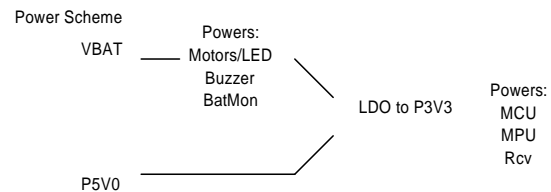

MARK[1-3] FIDUCIAL MARK MH[1-2] MH/3.2mm

PROJECT:	MotionSense v1
SHEET NAME:	TOP
DATE: 25.11.2015	UNIVERSITY OF OSLO
VER:	Dept. of Physics ELAB
SHEET: 1 / 4	(c) copyright. All rights reserved.

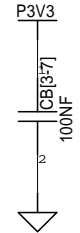
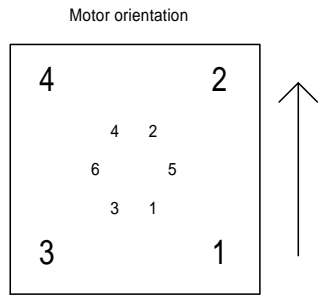

Er 8 MHz på Naze, sjekk på kortet

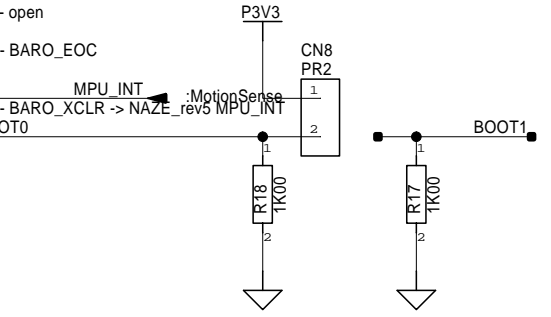
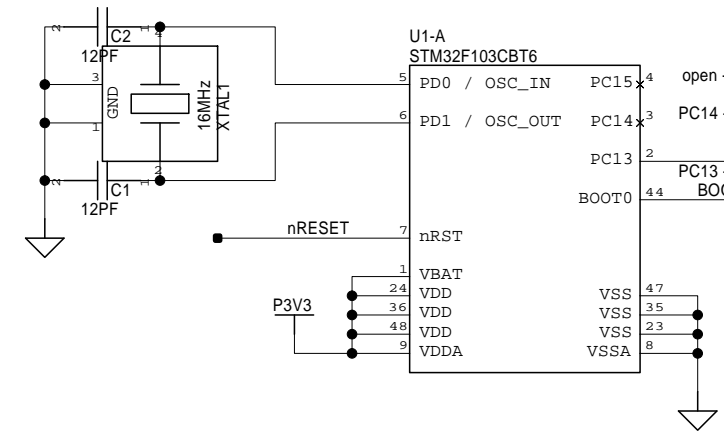

BUZZER

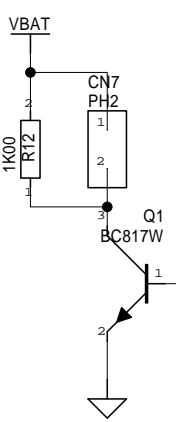

BATMON

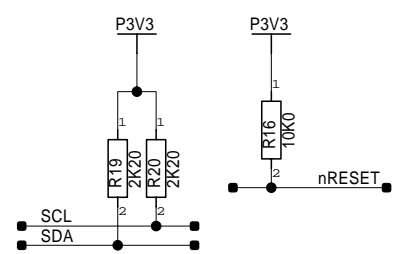
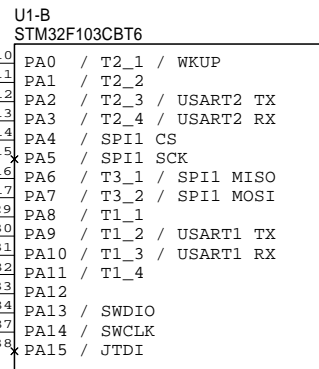
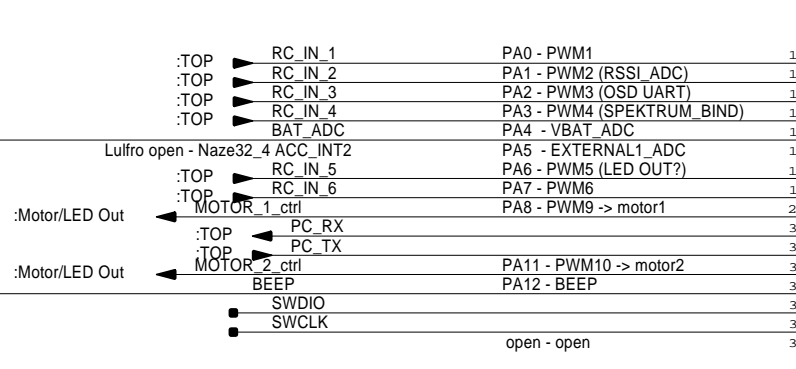
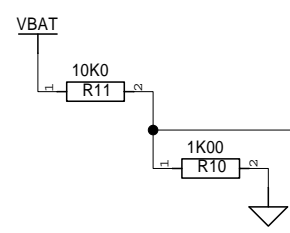

LEDs

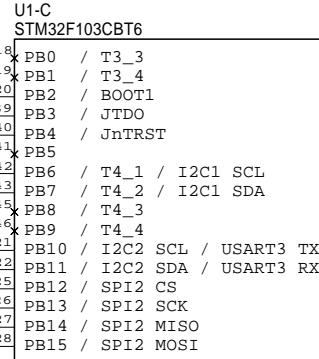
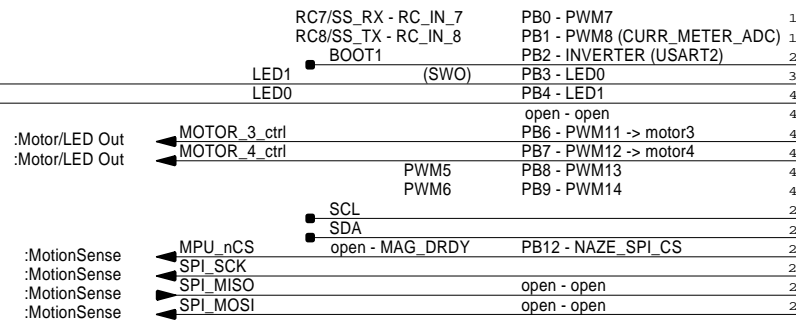
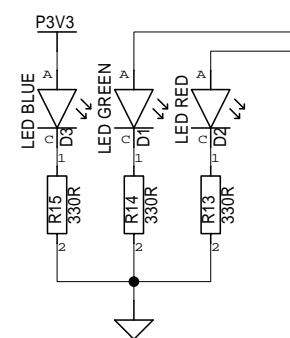

PROG

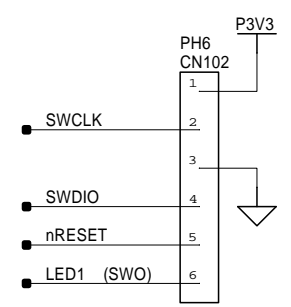

Tror ikke hvilken motor som er mappet til hvilken PWM9-14 er viktig, står at PWM14 -> motor4 i kode kommentarer, men alle PWM9-14 er mappet til motorer? PWM1-8 er mappet til RC input.

PROJECT:	MotionSense v1
SHEET NAME:	MCU
DATE: 25.11.2015	UNIVERSITY OF OSLO
VER:	Dept. of Physics ELAB
SHEET: 2 / 4	(c) copyright. All rights reserved.

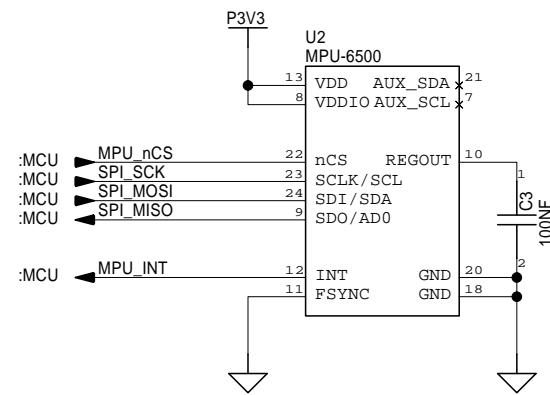
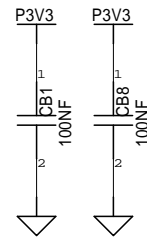
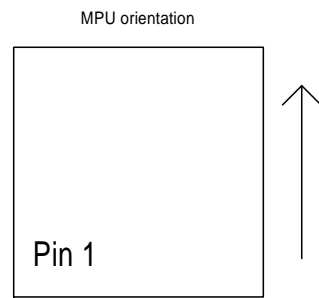

PROJECT:	MotionSense v1
SHEET NAME:	MotionSense
DATE: 25.11.2015	UNIVERSITY OF OSLO
VER:	Dept. of Physics ELAB
SHEET: 3 / 4	(c) copyright. All rights reserved.

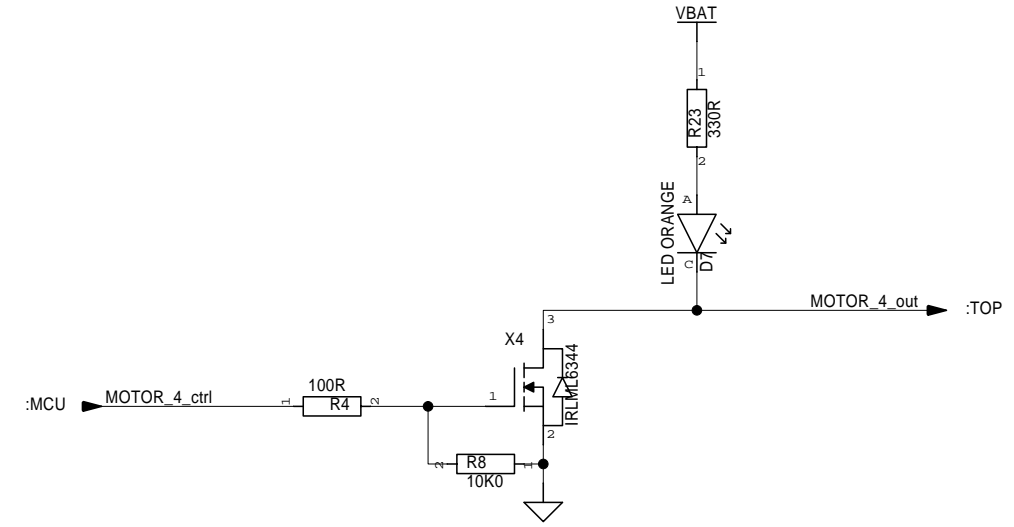
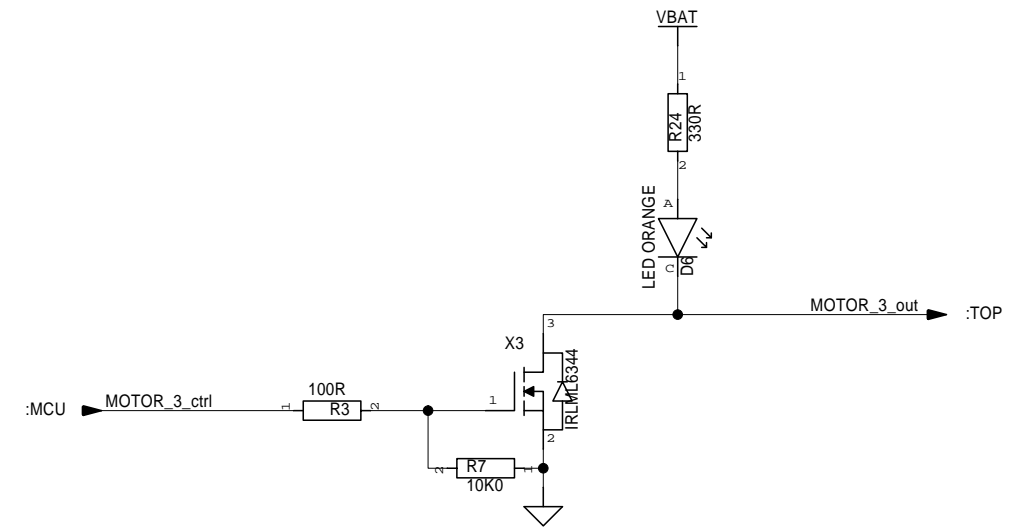
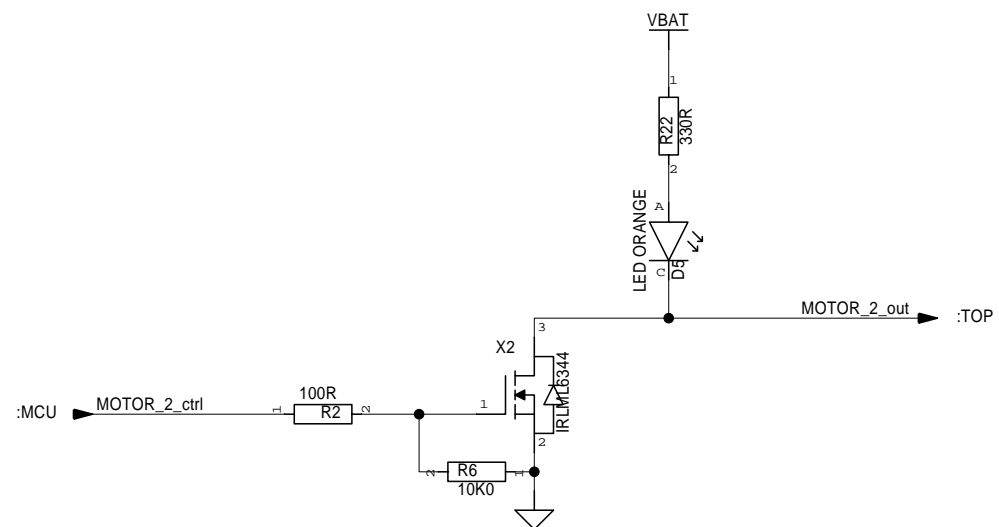
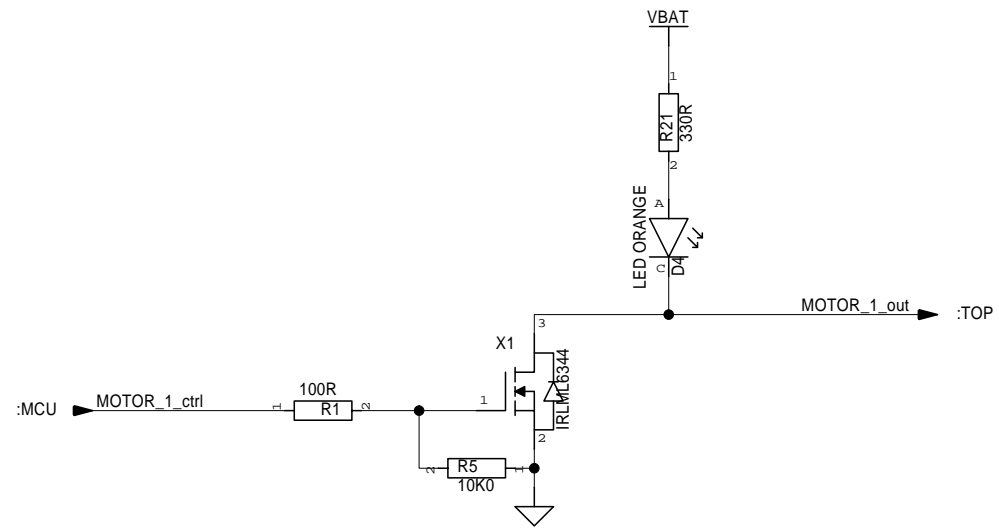

PROJECT:	MotionSense v1
SHEET NAME:	Motor/LED Out
DATE:	25.11.2015
VER:	
SHEET:	4 / 4
<small>(c) copyright. All rights reserved.</small>	