



UiO • **Institutt for informatikk**
Det matematisk-naturvitenskapelige fakultet

IN3160, IN4160

Introduction to VHDL
Basic layout for VHDL

Yngve Hafting



Messages:

- Assignment 2 is revised
 - Please re-load from canvas.
 - Do try program the boards on LISP.
 - Report problems to lab supervisors.
- Please select a LISP machine, by writing your user name on <https://docs.google.com/spreadsheets/d/1Xyr6HJnZzmHxpaLTAEDMDBz0qIXPJdZMPbqneaP4CLg/edit#gid=0>
- Please negotiate timeslots with your fellow students sharing machine

Course Goals and Learning Outcome

<https://www.uio.no/studier/emner/matnat/ifi/IN3160/index-eng.html>

In this course you will learn about the **design of advanced digital systems**. This includes programmable logic circuits, a **hardware design language** and system-on-chip design (processor, memory and logic on a chip). **Lab assignments provide practical experience in how real design can be made.**

After completion of the course you will:

- understand important **principles for design** and testing of digital systems
- understand the **relationship between behavior and different construction criteria**
- be able to **describe advanced digital systems** at different levels of detail
- be able to perform simulation and synthesis of digital systems.

Goals for this lesson:

- Know the basic structure of VHDL
 - Know which design entities there are
 - Know how assignment and statements works
 - Know the basic functionality of processes
 - Be able to create designs using VHDL
 - Know the relation between physical signals and their declaration.
 - Know the difference between basic coding styles
- Know basic layout principles
 - Guidelines for capital letters
 - Basic layout types
 - Principles for indentation, commenting, naming, punctuations

Overview

- Repetition
- VHDL Structure
 - Design entities
 - Signals, variables, vectors
 - Processes
 - Libraries
 - STD_LOGIC
 - Operators
 - String literals
- Code layout principles
- Next lesson: Combinational logic
 - Assignments and suggested reading for this week

HDL

- VHDL = VHSIC HDL:
 - Very High Speed Integrated Circuit **Hardware Description Language**
 - The purpose is to generate hardware, and verify it through simulation.
 - **Synthesizable (realizable) code work concurrently (in parallel).**
 - Code for simulation include things such as file I/O which cannot be synthesized.
 - Testbenches can and will use some synthesizable elements, but will in general look more like other sequential languages, and use sequential statements.
This may be confusing at times...
 - VHDL does come with several libraries.

REPETITION

HDL

Code for generating and parsing simulation data (Test benches)

code for generating multiple instances or variants of entities

Synthesizable code

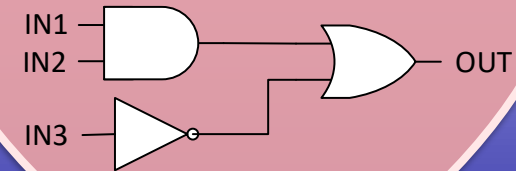

HDL vs software

```
process(reset, clk)
begin
    if (reset = '1') then
        sum <= '0';
    elsif rising_edge(clk) then
        sum <= a + b;
    end if;
end process;
```

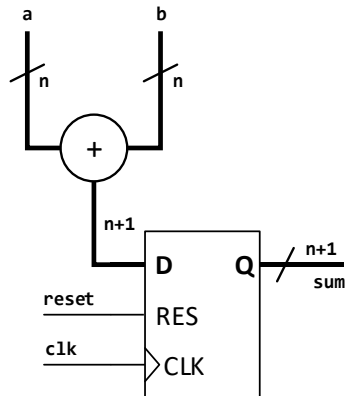

HDL «Hardware description language»	Software programs
Defines the logic function of a circuit	Defines the sequence of instructions and which data shall be used for one or more processors or processor cores
CAD tools <i>syntetizises</i> designs to enable realization using physical gates.	A compiler translates program code to <i>machine code instructions</i> that the processor can read sequentially from memory
Implemented using programmable logic (PL, FPGA, CPLD, PLD, PAL, PLA, ...) or ASICs (application specific circuits) (“ASICs”, processors, ..-chips,.. etc.)	Is stored in computer memory
Verilog (SystemVerilog) VHDL (VHDL 2008) (System C m. fl.)	C, C++, C#, Python, Java, assembler (ARM, MIPS, x86, ...) Fortran, LISP, Simula, Pascal, osv...

```
int sum(int a, int b){
    int s;
    s = a + b;
    return s;
}
```

```
MOV R5, #0 ;set base adr
LDR R7, [R5, #8] ;load reg R7
LDR R8, [R5, #12];load reg R8
ADD R0, R7, R8 ;R0=R7+R8
STR R0, [R5, #16];store R0
```

```
01001100 10011001 00100100 01001010
11001100 10111001 01100100 11110110
01001100 10011001 00111100 11101010
01001100 10011001 00100100 01011010
```

...
 (binary code is random, for illustration only)

VHDL structure

- Design entities
- Architecture styles
- Ports and signals
- Vectors
- Assignment
- Libraries
- STD_LOGIC data type
- Operators

VHDL Design entities overview 1/2

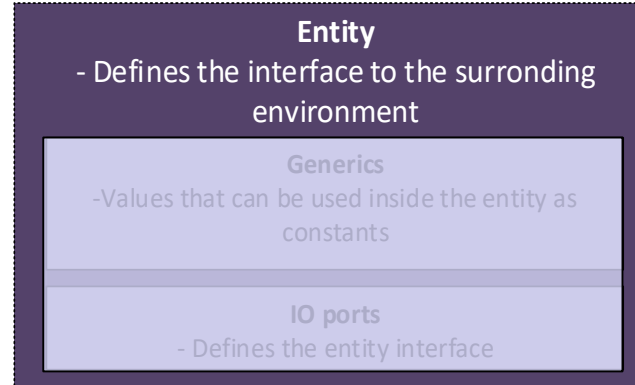

- Small design files will normally contain both entity and an architecture
- In larger designs these may be separated, several architectures can be used for one entity.
- *Details will be revealed later..*

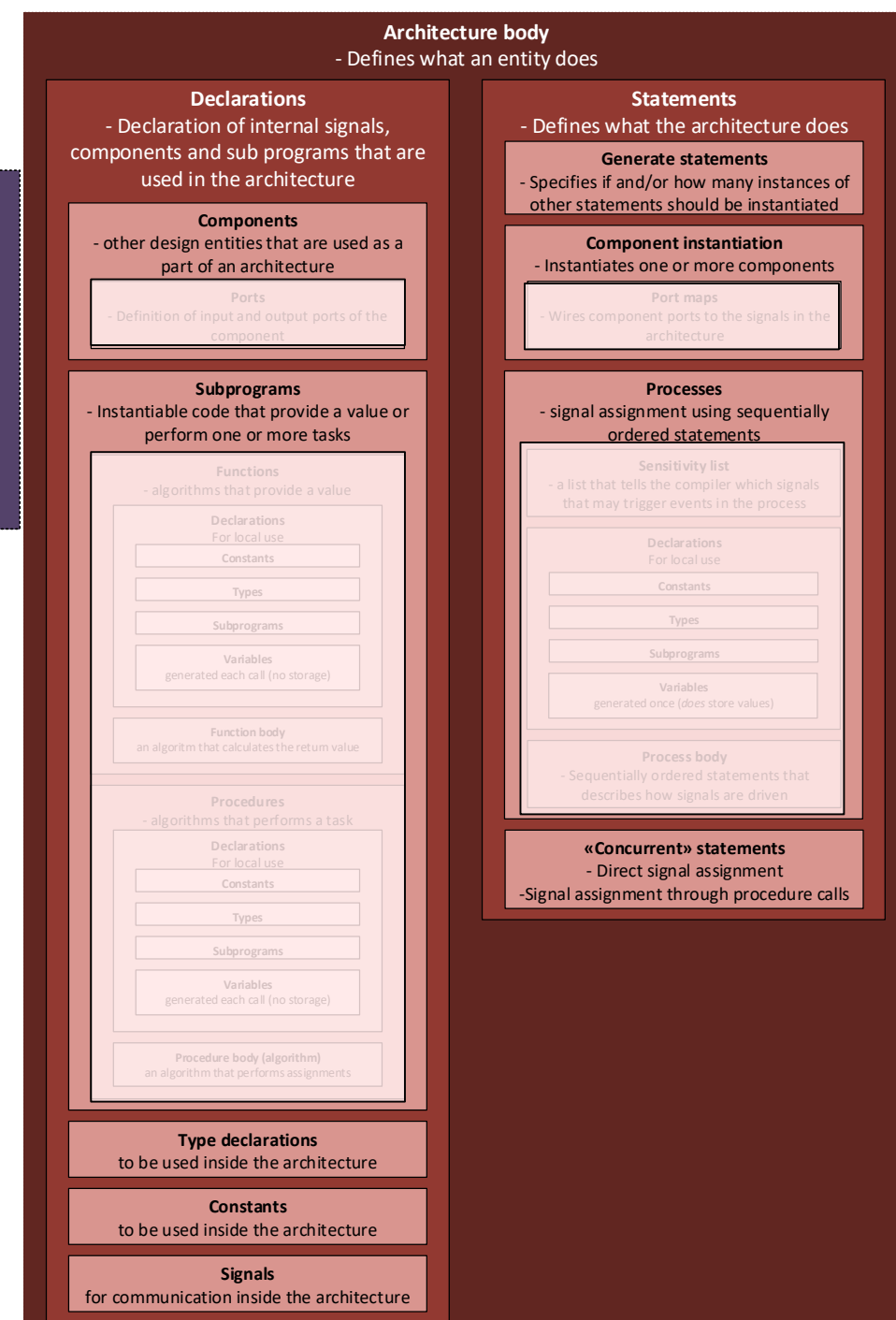

VHDL Design entities overview 2/2

- VHDL uses and can be used to create packages
- We will almost always use packages in precompiled libraries.
- Configuration files can be used to specify which components or architectures that shall be used in (large) designs
 - (Not a primary concern for in3160)

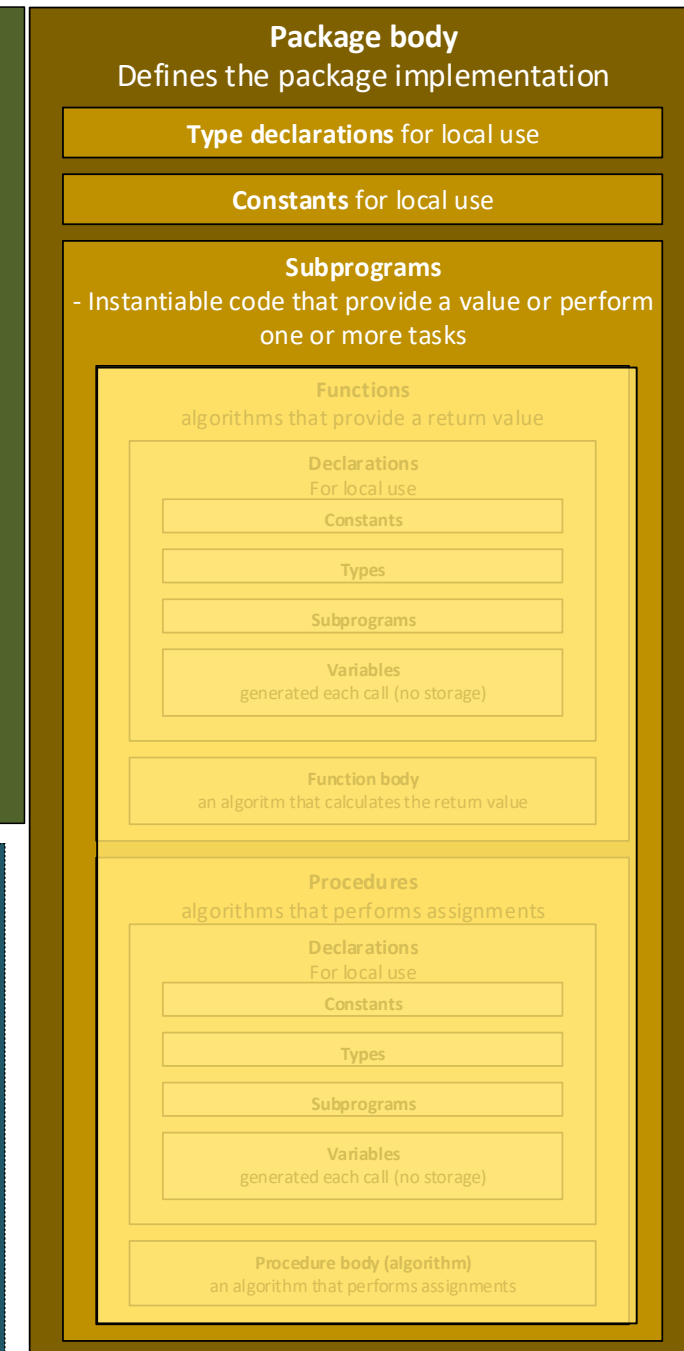
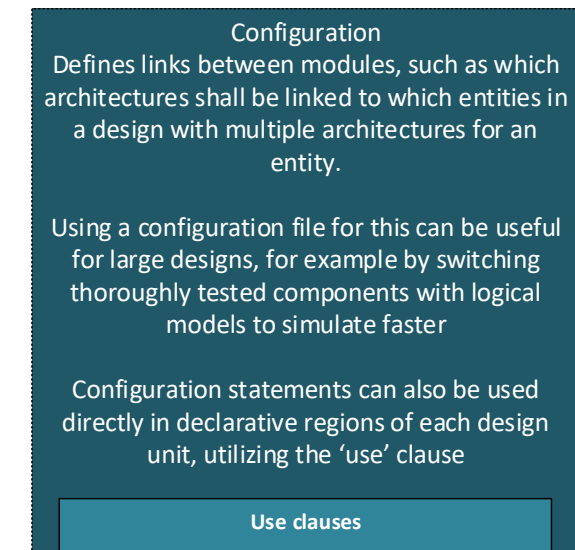
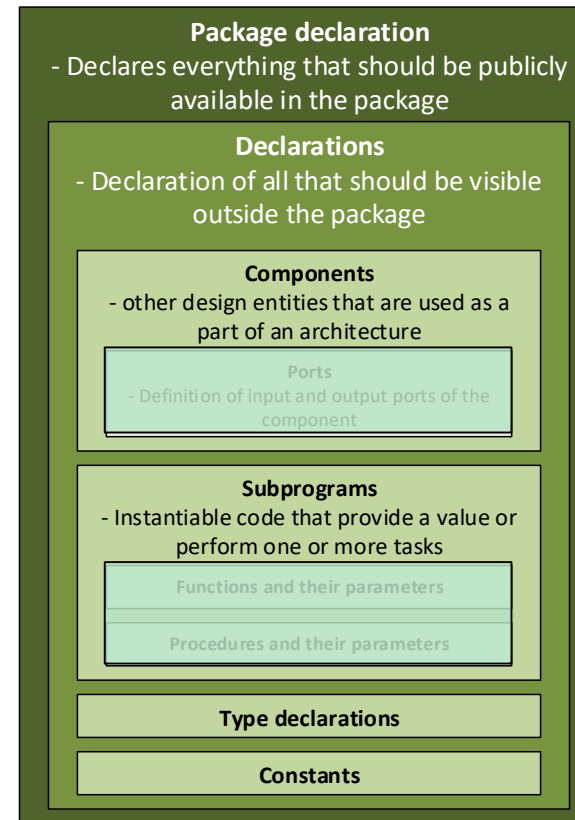

4 styles of architecture modeling

```
library IEEE;
use IEEE.STD_LOGIC_1164.all;
```

```
entity D_flipflop is
port(
  clk: in std_logic;
  D: in std_logic;
  Q: out std_logic
);
end entity D_flipflop;
```

```
architecture RTL of D_flipflop is
begin
  process (clk) is
  begin
    if rising_edge(clk) then
      Q <= 'D';
    end if;
  end process;
end architecture RTL;
```

```
architecture data_flow of D_flipflop is
  signal e, f, g, h, i, j, k, l: std_logic;
begin
  -- concurrent statements
  e <= not (D and clk);
  f <= not (e and clk);
  g <= not (e and h);
  h <= not (f and g);
  i <= not (g and not clk);
  j <= not (h and not clk);
  k <= not (l and i);
  l <= not (k and j);
  Q <= k;
end architecture data_flow;
```

RTL, register transfer level

- easy to read
- describes registers and what happens between them
- «default» for sequential logic

Data Flow

- typically used for simple concurrent statements
- will easily become unreadable if used extensively.

Behavioral

- *Simulation models only*
- Not for synthesis or implementation

```
library IEEE;
use IEEE.STD_LOGIC_1164.all;

entity my_thing is
port (
  A: in std_logic;
  B: in std_logic_vector(5 downto 0);
  C, D, E, F: in std_logic;
  G: out std_logic;
  H: out std_logic_vector(64 downto 0);
  I: out std_logic
);
end entity my_thing;
```

```
architecture structural of my_thing is
  signal js: std_logic;
  signal ks: std_logic_vector(64 downto 0);
  signal ls: std_logic;

  component apple is
  port (
    A: in std_logic;
    B: in std_logic_vector(5 downto 0);
    C: out std_logic;
    D: out std_logic_vector(64 downto 0)
  );
  end component;

  component pear is
  port (
    A, B, C: in std_logic;
    D, E: out std_logic
  );
  end component;

  component banana is
  port (
    smurf: in std_logic_vector(64 downto 0);
    cat, dog, donkey: in std_logic;
    horse: out std_logic;
    monkey: out std_logic_vector(64 downto 0)
  );
  end component;

begin -- port map (component => My_thing)
  U1: apple port map(
    A => A,
    B => B,
    C => js,
    D => ks
  );

  U2: pear port map(
    A => D,
    B => E,
    C => F,
    D => ls,
    E => I
  );

  U3: banana port map(
    smurf => ks,
    cat => js,
    dog => C,
    donkey => ls,
    horse => G,
    monkey => H
  );
end architecture structural;
```

Structural

- Ties components together
- Typically used in test benches, and when using predefined components

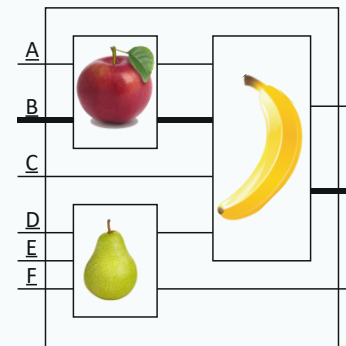

Ports and signals

- Ports define the entity interface
 - IN:
 - *can only drive*
 - cannot read or be assigned to a signal
 - OUT:
 - *signals can only be driven*
 - They should be assigned in the architecture
(In VHDL 2008, output ports can be read as an internal signal).
 - INOUT
 - *Can be both driven and read*
(typical use is for buses)
- Signals are internal
 - For connecting internal modules, subprograms and processes.

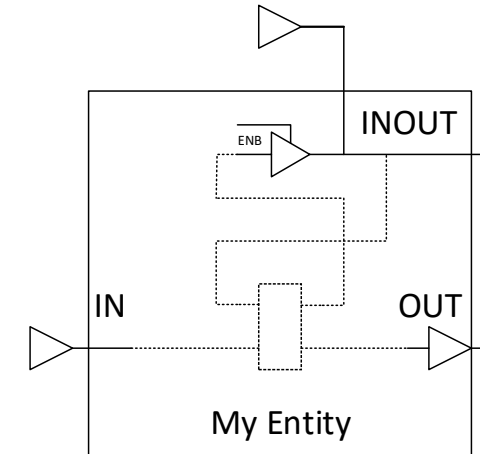

```
library IEEE;
use IEEE.STD_LOGIC_1164.ALL;

entity My_thing is
    port(
        Ain      : in  STD_LOGIC;
        Binout   : inout STD_LOGIC;
        Cout     : out STD_LOGIC);
end entity My_thing;

architecture DataFlow of My_thing is
    signal s1, s2, s3, s4 : STD_LOGIC;

begin
    -- ...

    -- concurrent statements
    s1      <= Ain;      -- IN can only drive
    s2      <= Binout;  -- INOUT *can* be driven
    Binout  <= s3;      -- INOUT *can* drive
    Cout    <= s4;      -- OUT can only be driven
end architecture DataFlow;
```

Ports continued

INOUT is for tying input and output to the same pin

- *should* implement tristate functionality.
- 'Z' means it is not driven (tristate)
- Typically to be used when connecting a bus that can have multiple drivers.

DO NOT use INOUT for convenience!

- The compiler will not alert you if you are driving from two sources simultaneously.
 - *May cause electrical faults*
- INOUT may infer inferior structures (long delays)
-

use an extra signal *unless you need to assign both input and output to the same physical location.*

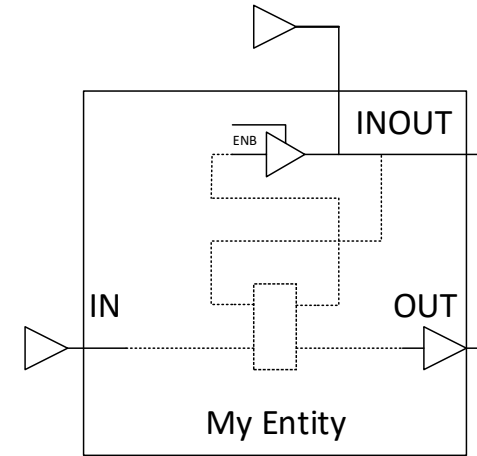

```
library IEEE;
use IEEE.STD_LOGIC_1164.ALL;

entity My_thing is
  port(
    Ain      : in  STD_LOGIC;
    Binout   : inout STD_LOGIC;
    Cout     : out STD_LOGIC);
end entity My_thing;

architecture DataFlow of My_thing is
  signal s1, s2, s3, s4 : STD_LOGIC;

begin
  -- ...

  -- concurrent statements
  s1      <= Ain;      -- IN can only drive
  s2      <= Binout;  -- INOUT *can* be driven
  Binout  <= s3;      -- INOUT *can* drive
  Cout    <= s4;      -- OUT can only be driven
end architecture DataFlow;
```

Type «Vectors»

- `signal my_sig std_logic;`

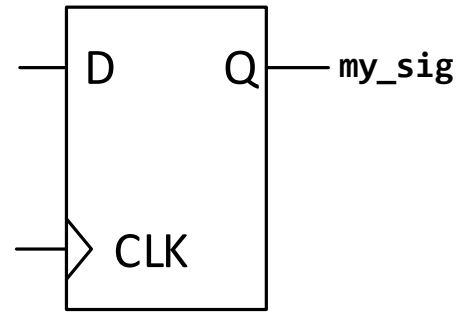
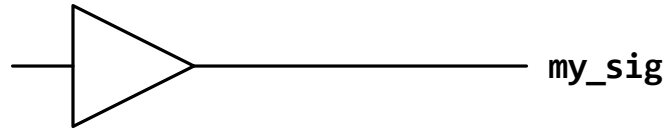

- `signal my_vec std_logic_vector(3 downto 0);`

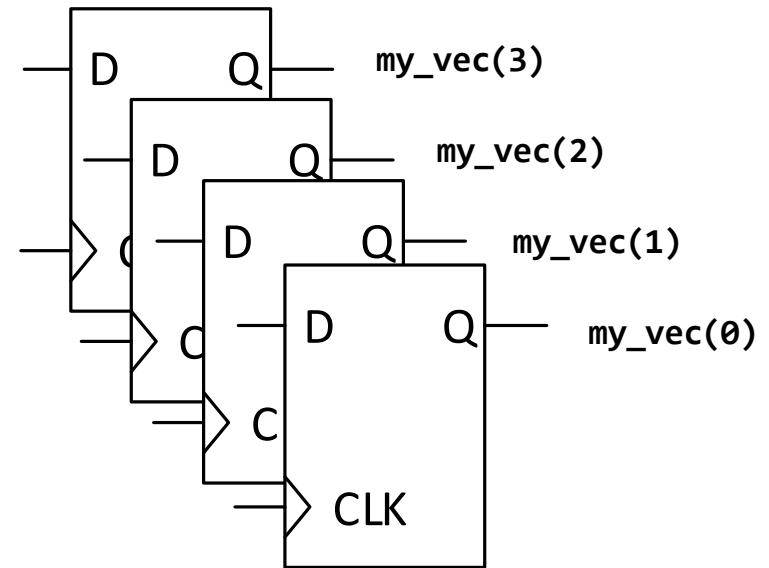
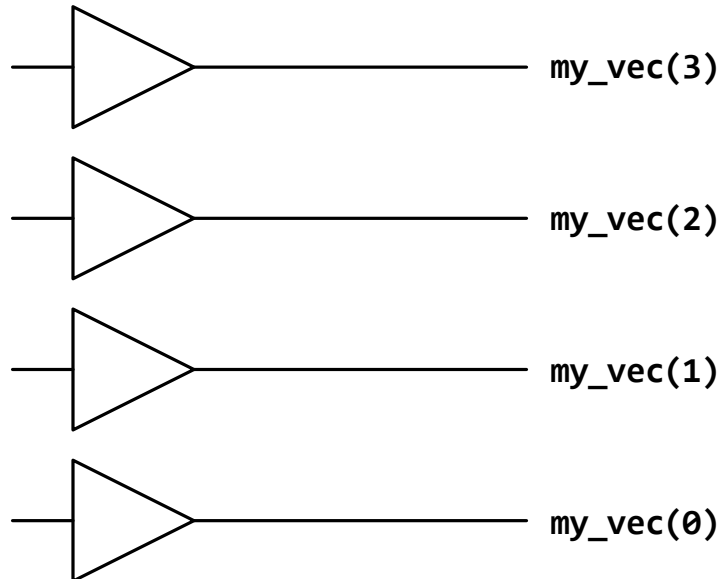

Signals and variables

- Signals are for inter-architecture communication
 - Between processes, modules and subprograms
- Variables are subprogram(or process)-internal
 - To make code clearer, and more local.
- Example note:
 - placement of s&v declarations
 - Signal assignment order is irrelevant outside processes

```
architecture example of sigvar is
  -- (signal) declarations
  signal S, T : std_logic;

begin
  -- statements
  S <= A and B;

  process (A,B) is
    -- (variable) declarations
    variable V : std_logic;
  begin
    -- process body
    V := '0';
    -- ...

  end process;

  X <= S XOR T;
end architecture;
```

Signal and variable assignment

- Signals can be used concurrently
 - both in and outside processes
 - Signals are assigned using `<=`
 - Signals uses event based updates
 - ie after a process is complete.
- Variables can only be used inside processes and subprograms
 - Variables are assigned using `:=`
 - Variables are updated immediately in simulation
 - *Processes can have variables store values*
 - *Initialized at the beginning of simulation*
 - *Subprograms (procedure, function) can not have variables store values*
 - *initialized on every call*

```
A <= B; -- A reads B, or A is assigned to B's output,  
        -- (A is a signal)
```

```
C := B; -- C is given B's value, C is a variable  
        -- variables are used internally in processes.
```

```
D(6 downto 0) <= E(3 downto 1) & (others => '0');  
        -- D is a vector having 7 input signals  
        -- D(6) <= E(3)  
        -- D(5) <= E(2)  
        -- D(4) <= E(1)  
        -- D(3 downto 0) <= "0000"
```

Processes

- A process is one (concurrent) statement
 - Ensures one driver for each signal by using priority.
 - Signals are only updated only once..
 - The process body has sequential priority
 - Last assignment takes precedence over previous.
 - Variables can be assigned multiple times within a process body(!)
 - sensitivity list
 - determines when the process body is invoked *during simulation*
 - *Event triggered*
 - *Can be used to make sequential logic*
 - Clocked events infers flipflops (or latches)

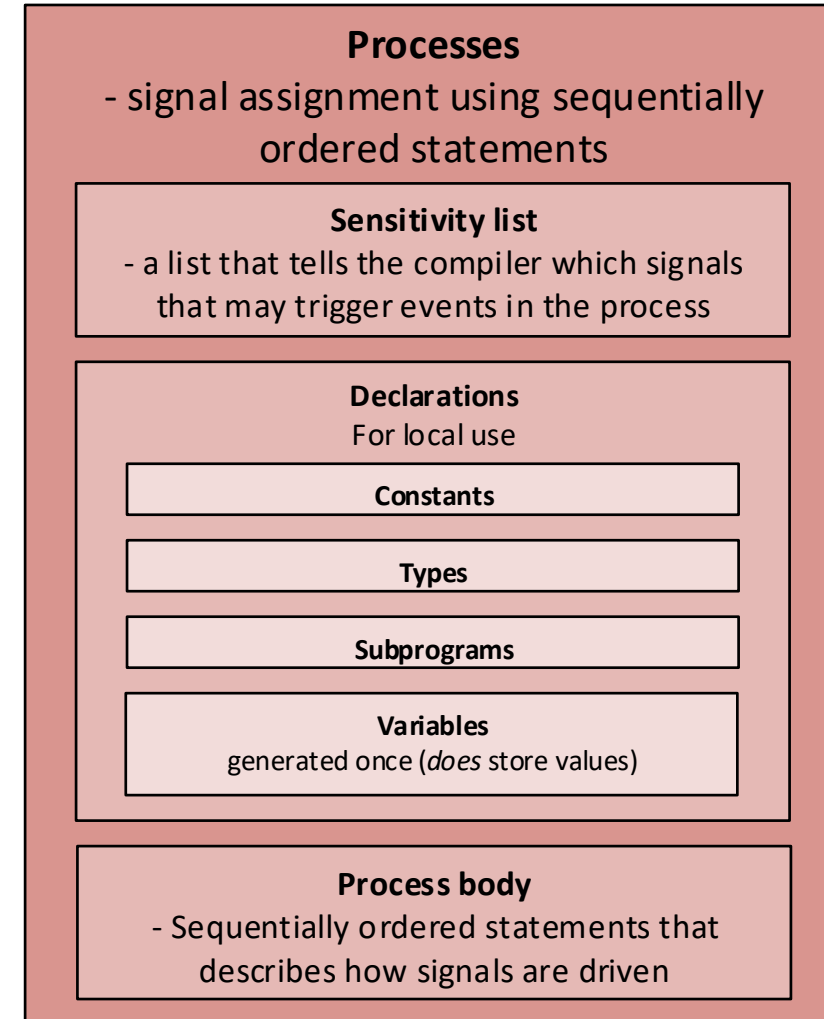

Process example

```
library IEEE;
use IEEE.std_logic_1164.all;

entity sigvar is
  port(
    A, B : in std_logic;
    X     : out std_logic
  );
end entity sigvar;
```

```
architecture example of sigvar is
  -- declarations
  signal S, T : std_logic;

begin
  -- statements
  S <= A and B;

  process (A,B) is
    -- decalarations
    variable V : std_logic;

  begin
    -- process body
    V := '0';
    if (A = '1') then
      V := '1';
    end if;
    if (B = '1') then
      V:= '1';
    end if;
    T <= V;
  end process;

  X <= S XOR T;
end architecture;
```

Libraries and Data types

- VHDL is built upon use of libraries and packages.
- You can both use existing ones, and create your own.
- Most used is the IEEE library, which contains
 - The built-in standard (std) package, containing:
 - bit, integer, natural, positive, boolean, string, character, real, time, delay_length
 - std_logic_1164 (which defines the STD_LOGIC type)
 - numeric_std (numeric operations for std_logic_vectors)
 - std_logic_textio (to provide IO during simulation)
 - numeric_bit (numeric operations for bit vectors)
 - etc.

STD_LOGIC TYPE (requires std_logic_1164 package from IEEE library)

- **STD_LOGIC** is a **type** that has the following possible values
 - ‘U’ Uninitialized (Typically seen in simulation before initializing values)
 - ‘X’ Unknown (typically when a signal is driven to both 0 and 1 simultaneously)
 - ‘0’ **Driven low**
 - ‘1’ **Driven High**
 - ‘Z’ **Tristate**
 - ‘W’ Weak unknown (when driven by two different weak drivers)
 - ‘L’ Weak ‘0’ (Typically for simulating a pulldown resistor)
 - ‘H’ Weak ‘1’ (Typically for simulating a pullup resistor)
 - ‘-’ Don’t care (Typically for assessing results in simulator).
- **You will only *assign*** (synthesizable) **signals to ‘0’, 1’ and ‘Z’**
- Type **STD_LOGIC_VECTOR** is array (NATURAL range <>) of **STD_LOGIC**
 - STD logic vector is used for hardware. For simulation, other types (such as integer) may be faster. Thus we use **STD_LOGIC** for hardware interactions, and other types when possible for test bench code.

std_logic -- values

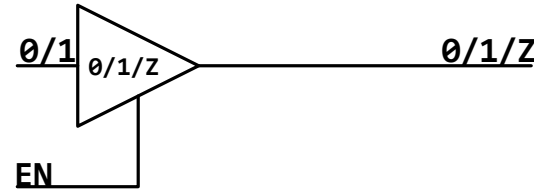

Value	Name	Usage
'U'	Uninitialized state	Used as a default value
'X'	Forcing unknown	Bus contentions, error conditions, etc.
'0'	Forcing zero	Transistor driven to GND
'1'	Forcing one	Transistor driven to VCC
'Z'	High impedance	3-state buffer outputs
'W'	Weak unknown	Bus terminators
'L'	Weak zero	Pull down resistors
'H'	Weak one	Pull up resistors
'_'	Don't care	Used for synthesis and advanced modeling

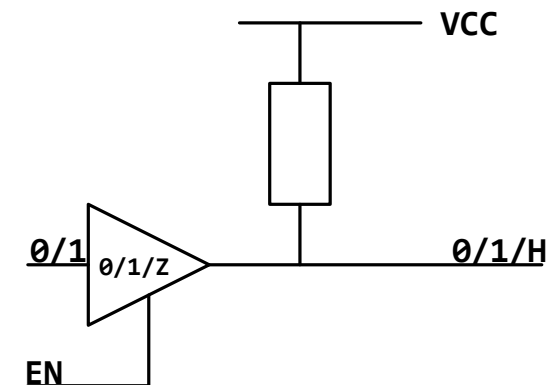
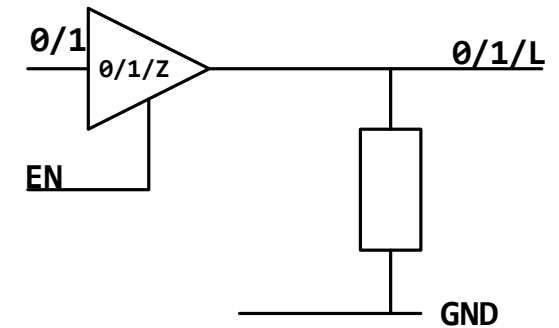
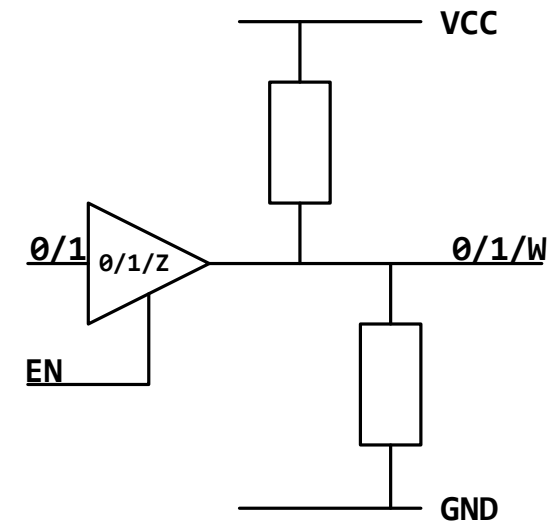

-- multiple drivers

signal c : std_logic;

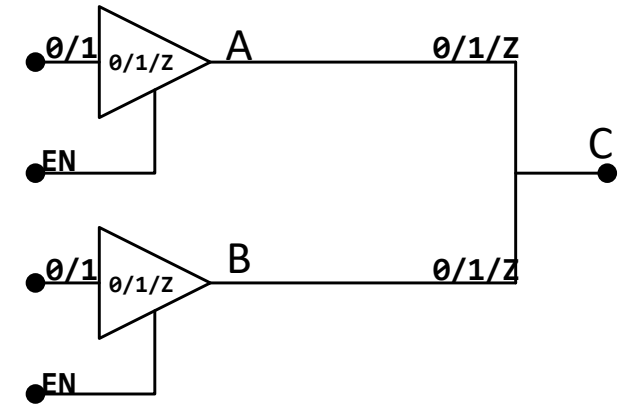

Signal A/B	'U'	'X'	'0'	'1'	'Z'	'W'	'L'	'H'	'_'
'U'	'U'	'U'	'U'	'U'	'U'	'U'	'U'	'U'	'U'
'X'	'U'	'X'	'X'	'X'	'X'	'X'	'X'	'X'	'X'
'0'	'U'	'X'	'0'	'X'	'0'	'0'	'0'	'0'	'X'
'1'	'U'	'X'	'X'	'1'	'1'	'1'	'1'	'1'	'X'
'Z'	'U'	'X'	'0'	'1'	'Z'	'W'	'L'	'H'	'X'
'W'	'U'	'X'	'0'	'1'	'W'	'W'	'W'	'W'	'X'
'L'	'U'	'X'	'0'	'1'	'L'	'W'	'L'	'W'	'X'
'H'	'U'	'X'	'0'	'1'	'H'	'W'	'W'	'H'	'X'
'_'	'U'	'X'	'X'	'X'	'X'	'X'	'X'	'X'	'X'

Tri-state buffer

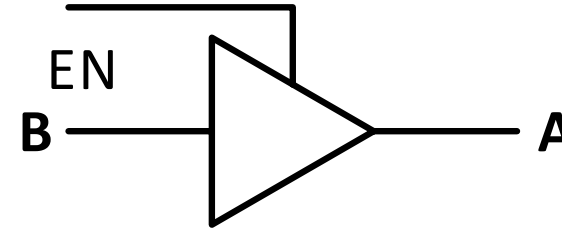

- Hardware can only read '0' or '1'
- We can set tristate (high impedance) to allow other sources to drive a bus.
- Simulation tools can use all possible `STD_LOGIC` values.

```
A <= B when EN = '1' else 'Z';
```

```
-- ekvivalent med  
TRISTATE:  
process (B,EN)  
begin  
    if EN = '1' then  
        A <= B;  
    else  
        A <= 'Z';  
    end if;  
end process;
```

VHDL operator priority

- Functions are interpreted from left to right (in reading order).
- **Use paranthesis to govern priority!**

Prioritet	Operator klasse	Operatorer
1 (first)	miscellaneous	** , abs, not
2	multiplying	* , /, mod, rem
3	sign	+ , -
4	adding	+ , -, &
5	Shift	sll, srl, sla, sra, rol, ror
6	relational	=, /=, <, <=, >, >=, ?=, ?/=, ?<, ?<=, ?>, ?>=
7	logical	And, or, nand, nor, xor, xnor
8 (last)	condition	??

Examples (elaboration on next page):

a <= a **or** b **and** c; **==** a <= (a **or** b) **and** c;

z <= a **and not** b **and** c; **==** z <= a **and** (**not** b) **and** c; **==** z <= c **and** (a **and** (**not** b));

y <= a **and not** (b **and** c); **-- z=1 kun for a=1, b=0, c=1. y=1 for a=1 og (b eller c)=0.**

VHDL operator priority

Examples:

`x <= a or b and c;` == `x <= (a or b) and c;`

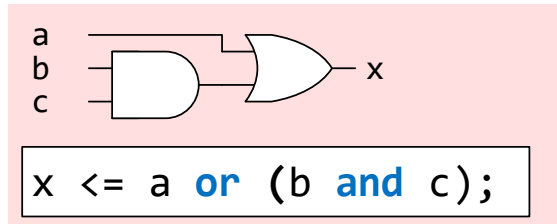

(What you might want)

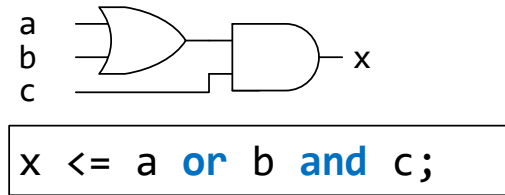

(what you actually will get)

Try

`a := '1'`
`b := '1'`
`c := '0'`

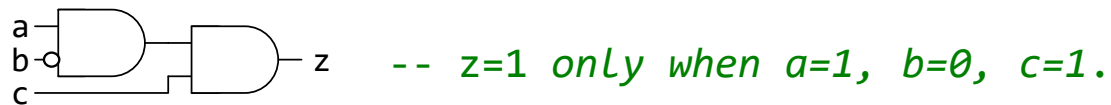

`z <= a and not b and c;` == `z <= a and (not b) and c;` == `z <= c and (a and (not b));`
`y <= a and not (b and c);`



Bit operators and reduction operator

- **and**, **or**, **not**, **xor**, **xnor** operators will work at bit level when they are placed between two signals or vectors.

- $y1 \leftarrow a \text{ and } b$; -- is equal to the lines below

$y1(3) \leftarrow a(3) \text{ and } b(3)$;

$y1(2) \leftarrow a(2) \text{ and } b(2)$;

$y1(1) \leftarrow a(1) \text{ and } b(1)$;

$y1(0) \leftarrow a(0) \text{ and } b(0)$;

- In VHDL2008 (not earlier) these operators can be used for reduction

$y \leftarrow \text{and } a$; -- is equal to the figure ->

- **xor** can be used this way to generate (even) parity for a signal.

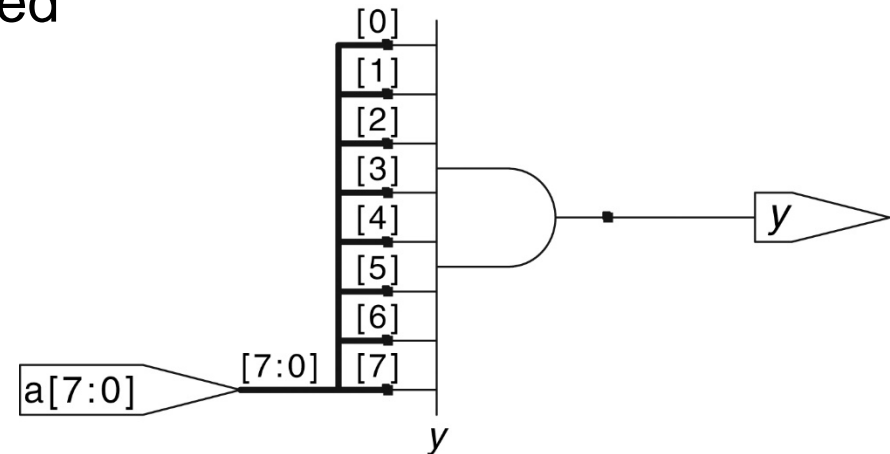
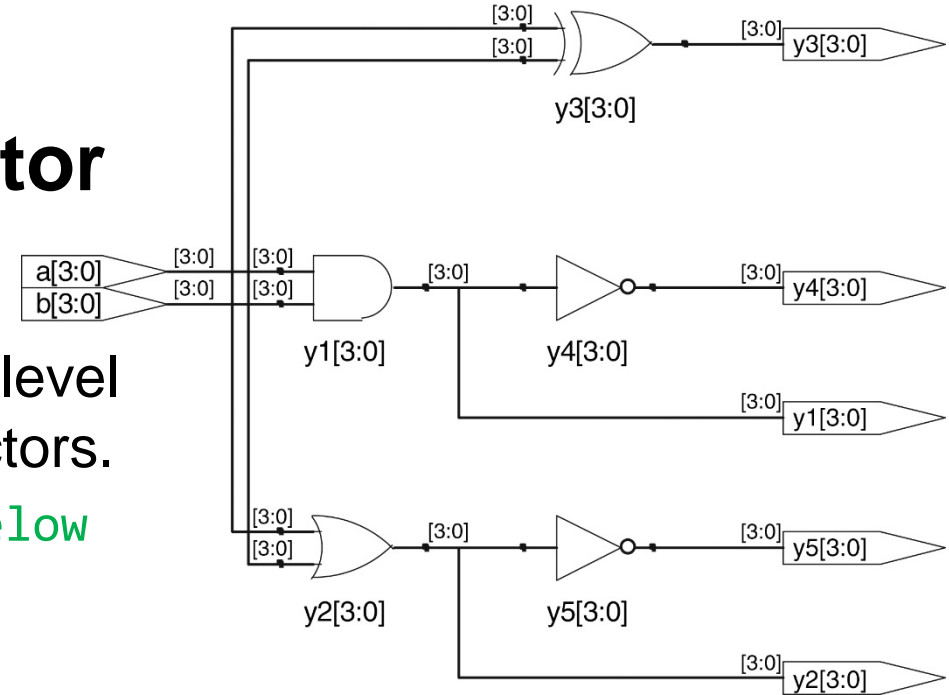

VHDL Bit String Literals

Binary, Decimal, hexadecimal, Octal, Unsigned, Signed

<ant bit><U/S><B/D/O/X><numbers of type B/D/O/X >

B"1111_1111_1111" -- Equivalent to the string literal

"111111111111".

X"FFF" -- Equivalent to B"1111_1111_1111".

O"777" -- Equivalent to B"111_111_111".

X"777" -- Equivalent to B"0111_0111_0111".

B"XXXX_01LH" -- Equivalent to the string literal

"XXXX01LH"

UO"27" -- Equivalent to B"010_111"

UO"2X" -- Equivalent to B"011_XXX"

SX"3W" -- Equivalent to B"0011_WWWW"

D"35" -- Equivalent to B"100011"

12UB"X1" -- Equivalent to B"0000_0000_00X1"

12SB"X1" -- Equivalent to B"XXXX_XXXX_XXX1"

12UX"F-" -- Equivalent to B"0000_1111_----"

12SX"F-" -- Equivalent to B"1111_1111_----"

12D"13" -- Equivalent to B"0000_0000_1101"

12UX"000WWW" -- Equivalent to B"WWW_WWW_WWW"

12SX"FFFC00" -- Equivalent to B"1100_0000_0000"

12SX"XXXX00" -- Equivalent to B"XXXX_0000_0000"

8D"511" - Error (> 2⁸)

8UO"477" - Error (>2⁸)

8SX"0FF" - Error (cannot have 255 using 8 bit signed)

8SX"FXX" - Error (cannot extend beyond 8 bit)

IN3160
Code Layout (15 min)



Overview

- Why bother thinking about layout?
- What constitutes a good layout scheme?
- Basic layout types
- Indentation
- Paragraphs and spaces

Why bother thinking of layout?

```
pRoCeSS(clock,reset) bEGIn iF resET then oUTpuT <="0000"; eISE IF RISING_edge  
(Clock) tHEN cASE s Is When 1=>outPUT<="0001"; wHEN 2046=> oUTpuT <="0010";WheN  
31=>OutPut<="0100";when OTHERs=>OUTput <= «1111"; end CASE; END if; END proCESS; --  
Q.E.D.
```

A good layout scheme...

1. ...accurately matches the structure of the code
2. ...improves readability
3. ...affords changes
4. ...is consistent (few exceptions)
5. ...is simple (few rules)
6. ...is easy to use
7. ...is economic

Basic layout types

Block layout



Endline layout

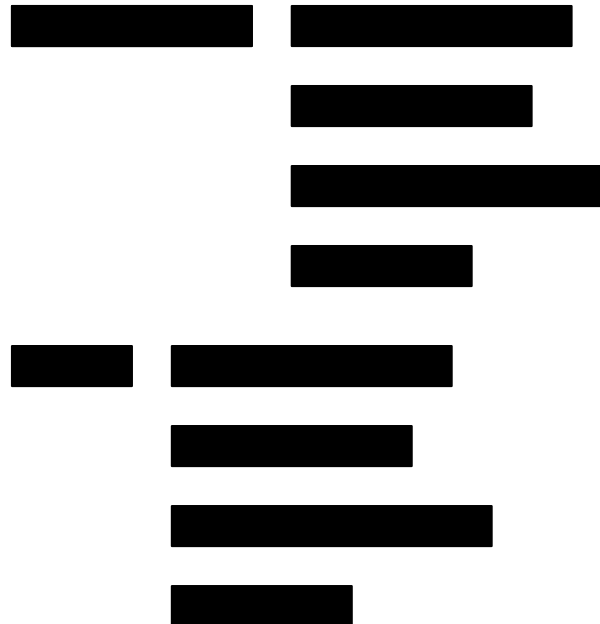

Column layout



Block layout (What you should use *most of the time*)

- Accurately matches structure
- relatively tidy
- readable,
- easy to maintain, etc.

```
process (clock, reset)
begin
  if reset then
    output <= "0000";
  else if rising_edge(clock) then
    case s is
      when 1 => output <= "0001";
      when 2046 => output <= "0010";
      when 31 => output <= "0100";
      when others => output <= "1111";
    end case;
  end if;
end process;
```

Endline layout (*avoid this*)

- Harder to maintain when code changes.
- Looks tidier, but isn't faster than pure block
- Will get messy- poor match of code hierarchy
- Long lines..!

```
process (clock, reset)
begin
  if reset then output <= "0000";
  else if rising_edge(clock) then case s is
    when 1 => output <= "0001";
    when 2046 => output <= "0010";
    when 31 => output <= "0100";
    when others => output <= "1111";
  end case;
  end if;
end process;
```

Column layout (use sparingly)

- Can be easier to read than pure block layout (scanning vertically)
- Harder to maintain.
- Best to use when columns are unlikely to change, and statements are related.
 - Typically used for 2D arrays.

```
process (clock, reset)
begin
  if reset then
    output <= "0000";
  else if rising_edge(clock) then
    case s is
      when 1 => output <= "0001";
      when 2 => output <= "0010";
      when 333 => output <= "0100";
      when others => output <= "1111";
    end case;
  end if;
end process;
```

Indentation

- *Use indentation to match code hierarchy*
- 2-4 spaces has been proven most efficient
 - *Along with a monospace font, such as courier, consolas..*
- Use space rather than tabulator sign.
 - Tabulator spaces may be interpreted differently in different editors.
 - Most editors can be set up for this.
- Example:

```
entity ent_name is
    generic (
        generic_declaration_1;
        generic_declaration_2;
    );
    port(
        port_declaration_1;
        port_declaration_2;
    );
end entity ent_name;
.
.
.
process (sensitivity_list)
    declaration_1;
    declaration_2;
begin
    statement_1;
    statement_2;
end process;
```

Paragraphs and comments

- Paragraphs should be used to separate chunks that does not need to be read all at once.
- Paired with comments that this make for good readability
- Comments should be indented as according to the code it is referring to.

```
-- Find character in text RAM corresponding to x, y
text_ram_x := pixel_x / FONT_WIDTH;
text_ram_y := pixel_y / FONT_HEIGHT;
display_char := text_ram(text_ram_x, text_ram_y);

-- Get character bitmap from ROM
ascii_code := character'pos(display_char);
char_bitmap := FONT_ROM(ascii_code);

-- Get pixel value from character bitmap
x_offset := pixel_x mod FONT_WIDTH;
y_offset := pixel_y mod FONT_HEIGHT;
pixel := char_bitmap(x_offset)(y_offset);
```

Line length and wrapping

- Try to keep line length within reasonable limits
 - 80, 100 and 120 characters is widely used.
- When wrapping lines:
 - break at a point that clearly shows it is incomplete, such as
 - after opening paranthesis
 - after operators or commas (&, +, -, *, /)
 - after keywords such as «and» or «or»
 - consider one item per line...

```
-- one item/line + named association
Paddle <= update_sprite(
  sprite => paddle,
  sprite_x => paddle_position.x + paddle_increment.x,
  sprite_y => paddle_position.x + paddle_increment.y,
  raster_x => vga_raster_x,
  raster_y => vga_raster_y,
  sprite_enabled => true
);
```

```
-- several items/line
paddle <= update_sprite(paddle, paddle_position.x + paddle_increment.y,
  paddle_position.y + paddle_increment.y, vga_raster_x, vga_raster_y, true);
```

Spaces

- Punctuation symbols
(comma, colon, semicolon)

- use spaces as you would in regular prose:

- Never add space before punctuation symbols
- Always add space after punctuation symbols

- *no exceptions*

- Parentheses

- Add a space before opening parenthesis.

- Add a space or punctuation symbol after closing parenthesis

- Except:

- array indices and routine parameters;
- *expressions*.

```
-- too much
function add ( addend : signed ; augend : signed ) return signed ;
```

```
-- better
function add(addend: signed; augend: signed) return signed;
```

```
-- consider this expression:
a + b mod c sll d;
```

```
-- better
(a + (b mod c)) sll d;
```

```
-- consider
(-b+sqrt(b**2-4*a*c))/2*a;
```

```
-- better
(-b + sqrt(b**2 - 4*a*c)) / 2*a;
```

```
-- too much
( - b + sqrt( b ** 2 - 4 * a * c ) ) / 2 * a;
```

Naming conventions - Letter case and underscores

```
noconventionnaming -- don't go there
UpperCamelCase -- OK used consequently
lowerCamelCase -- OK used consequently
snake_case or underscore_case
SCREAMING_SNAKE_CASE or ALL_CAPS
```

- Do not use ALL_CAPS too frequently.
- Use editor colors/ **bold** for highlighting **keywords**
- Try to avoid mixing snakes_andCamels.
- Treat acronyms/ abbreviations as words
 - "UDPHDRFromIPPacket" **vs**
"UdpHdrFromIpPacket" **vs**
"udp_hdr_from_ip_packet"
- VHDL packages tend to favour snake_case and ALL_CAPS
- *Suggestion:*
 - Use **snake_case** for all **names** except **constants** and **generics** that use **ALL_CAPS**

Suggested reading, Mandatory assignments

- D&H:
 - 1.5 p 13-16
 - 3.6 p 51-54
 - 6.1 p 105-106
- Oblig 1: «Design Flow»
- Oblig 2: «VHDL»
 - See canvas for further instruction.

(Layout is lecture only)