



1) Calculate the semantics of Ex1, Ex2, Ex3

Let

$$t1 = \langle !a, ?a, !b, ?b, !c, ?c \rangle$$

$$t2 = \langle !a, !b, ?a, ?b, !c, ?c \rangle$$

$$t3 = \langle !a, ?a, !c, ?c \rangle$$

$$t4 = \langle !a, ?a, !b, ?b, !d, ?d, !c, ?c \rangle$$

$$t5 = \langle !a, !b, ?a, ?b, !d, ?d, !c, ?c \rangle$$

$$t6 = \langle !a, ?a, !b, ?b, !d, !c, ?d, ?c \rangle$$

$$t7 = \langle !a, !b, ?a, ?b, !d, !c, ?d, ?c \rangle$$

$$[[\text{Ex1}]] = \{ (\{t1, t2\}, \emptyset) \}$$

$$[[\text{Ex2}]] = \{ (\{t3\}, \{t1, t2\}) \}$$

$$[[\text{Ex3}]] = \{ (\{t1, t2\}, \{t4, t5, t6, t7\}) \}$$



2) Answer the following

a. Is Ex2 a refinement of Ex1?

Yes; t1 and t2 have been moved from the positive to the negative (narrowing), while t3 has been moved from the inconclusive to the positive (supplementing).

b. Is Ex1 a refinement of Ex2?

No; t1 and t2 have been moved from the negative to the positive, while t3 has been moved from the positive to the inconclusive.

c. Is Ex3 a refinement of Ex1?

Yes; The positive traces of Ex1 remain positive, while the traces t4,t5,t6 and t7 have been moved from the inconclusive to the negative (supplementing)

d. Is Ex1 a refinement of Ex3?

No; t4,t5,t6 and t7 have been moved from the negative to the inconclusive.



3) Make MySpec that refines Ex3

This can of course be solved in many ways; below is one suggestion. A new positive trace $t8 = \langle !e, ?e \rangle$ has been added (supplementing).

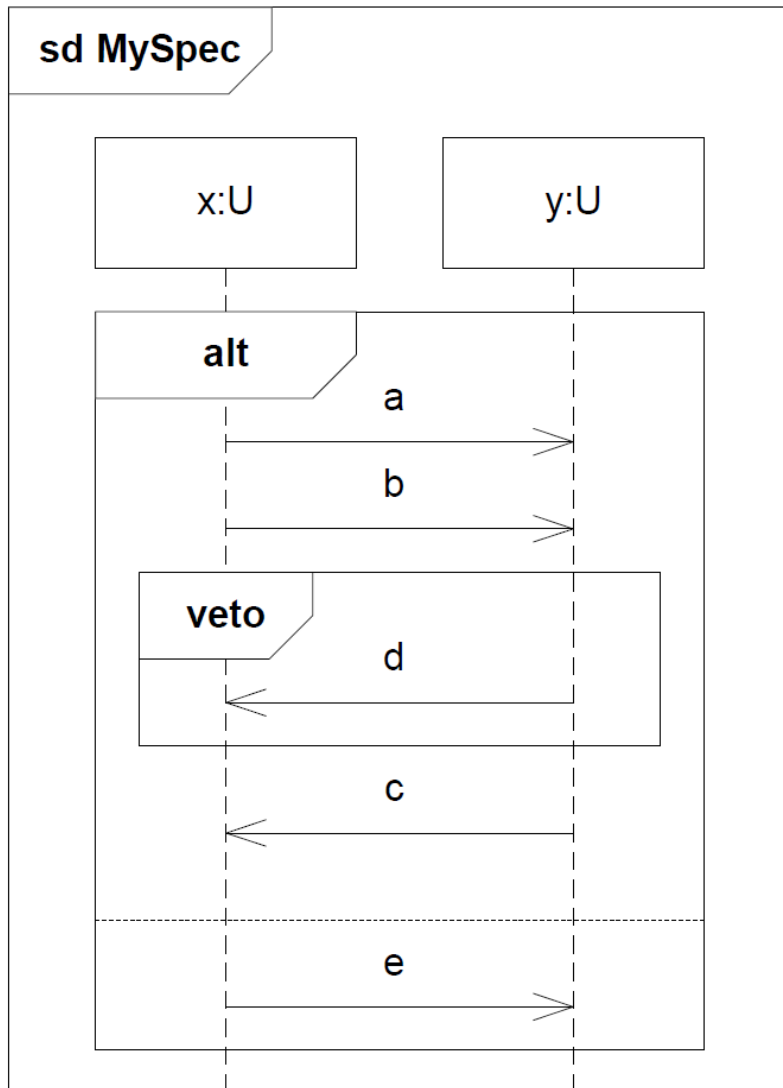



3) Continued

a. Is Ex1 a refinement of MySpec?

No; the traces t4,t5,t6,t7 and t8 are inconclusive in Ex1, but not in MySpec.

b. Is MySpec a refinement of Ex1?

Yes; The traces that are positive in Ex1 remain positive in MySpec, while new traces that were inconclusive in Ex1 have become either positive (t8) or negative (t4,t5,t6,t7) in MySpec (supplementing).



4) Is Ex7 a refinement of Ex6?

Yes. Let

$$t9 = \langle !f, ?f, !g, ?g \rangle \quad t10 = \langle !f, ?f, !h, ?h, !g, ?g \rangle$$
$$t11 = \langle !f, ?f, !h, !g, ?h, ?g \rangle$$

Then

$$[[\text{Ex6}]] = \{ (\{t1, t2, t9\}, \emptyset) \}$$

$$[[\text{Ex7}]] = \{ (\{t1, t2, t9\}, \{t4, t5, t6, t7, t10, t11\}) \}$$

The positive traces of $[[\text{Ex6}]]$ remain positive in $[[\text{Ex7}]]$, while new negative traces have been added (supplementing)