

INF3480/INF4380 - Assignment 1

Eirik Kvalheim and Jørgen Nordmoen

Due: Wednesday, March 1st 2017

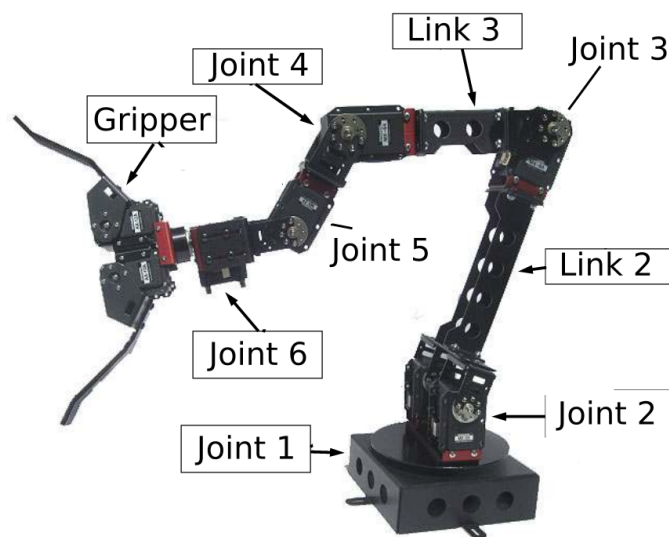

Figure 1: The CrustCrawler robot

Introduction

Figure 1 displays the CrustCrawler robot which we will work with in the compulsory assignments in INF3480/INF4380. The CrustCrawler is a six-axis robotic arm with an optional gripper attachment. The base of the arm is a turntable (*Joint 1*) which allows the arm to turn around its own axis. The arm itself is composed of 6 servo motors to allow for multiple degrees of freedom. Attached to the turntable is a double actuator joint (*Joint 2*), composed of two servos. *Link 2* connects *Joint 2* and *Joint 3*. We then have *Link 3*, connected to *Joint 4*. Connected directly to *Joint 4* is another servo, *Joint 5* which is parallel to *Joint 4*, *Joint 3* and *Joint 2*. Lastly the axis of rotation for *Joint 6* is perpendicular to the axis of rotation of *Joint 5*. The optional gripper is attached to *Joint 6*.

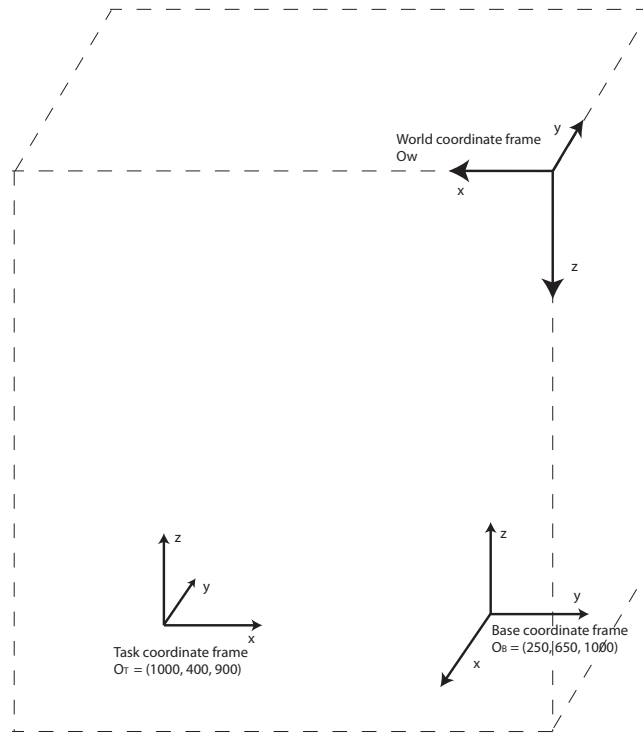

Figure 2: Coordinate frames (see also figure 4)

Task 1

Figure 2 shows three coordinate frames and the direction of the axes. We name the coordinate frames *World coordinate frame* $\{W\}$, *Base coordinate frame* $\{B\}$ and *Task coordinate frame* $\{T\}$.

Origin of coordinate frame $\{B\}$, relative to $\{W\}$, is located at position

$$O_B = (250, 650, 1000) \quad (1)$$

Origin of coordinate frame $\{T\}$, again relative to $\{W\}$, is located at position

$$O_T = (1000, 400, 900) \quad (2)$$

- The axes Z_W , Z_B and Z_T are parallel to each other
- The axes X_W , Y_B and X_T are parallel to each other
- The axes Y_W , X_B and Y_T are parallel to each other

Task Find T_T^B (the transformation matrix expressing the position and orientation of $\{T\}$ with respect to $\{B\}$).

NOTE: Show your solution by setting up the necessary expressions and calculations.

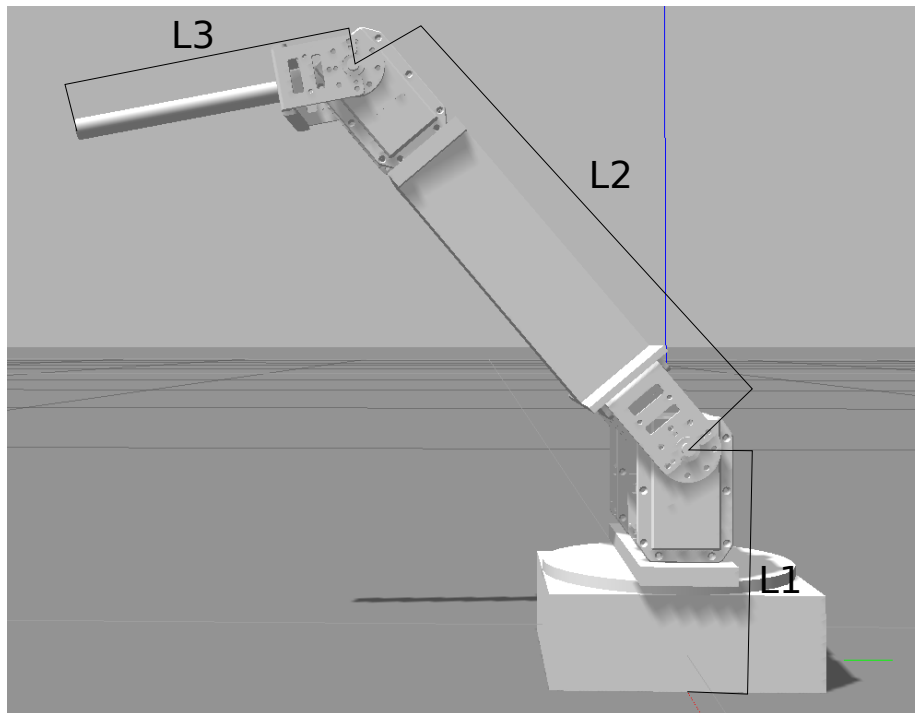

Figure 3: Simplified robot model

Task 2

To simplify the exercise we will now look at a restricted model of the CrustCrawler robot. We remove joints [4, 5, 6] so that the CrustCrawler resembles the arm shown in figure 3. This simplified version only has three joints and three links.

- Sketch the workspace of the robot.
- Draw a simple illustration of the robot, showing the coordinate frames and the Denavit-Hartenberg parameters. Explain briefly your choice of origin and rotation axis. Show the DH-parameters in a table.
- Calculate the forward kinematics for this robot. Your answer should be a transformation matrix T_T^B denoting the transformation of the task coordinate frame $\{T\}$ located at the tip of the arm, with respect to the base coordinate frame $\{B\}$. This transformation matrix is a function of the angles of the three joints.

Task 3

Point p is located at the tip of the robot (the last link). We adjust the robot as displayed in figure 4, where $\phi_1 = 270^\circ$, $\phi_2 = 60^\circ$, $\phi_3 = 45^\circ$. These angles are of course not to be used directly, you have to figure out the correct θ -angles for your

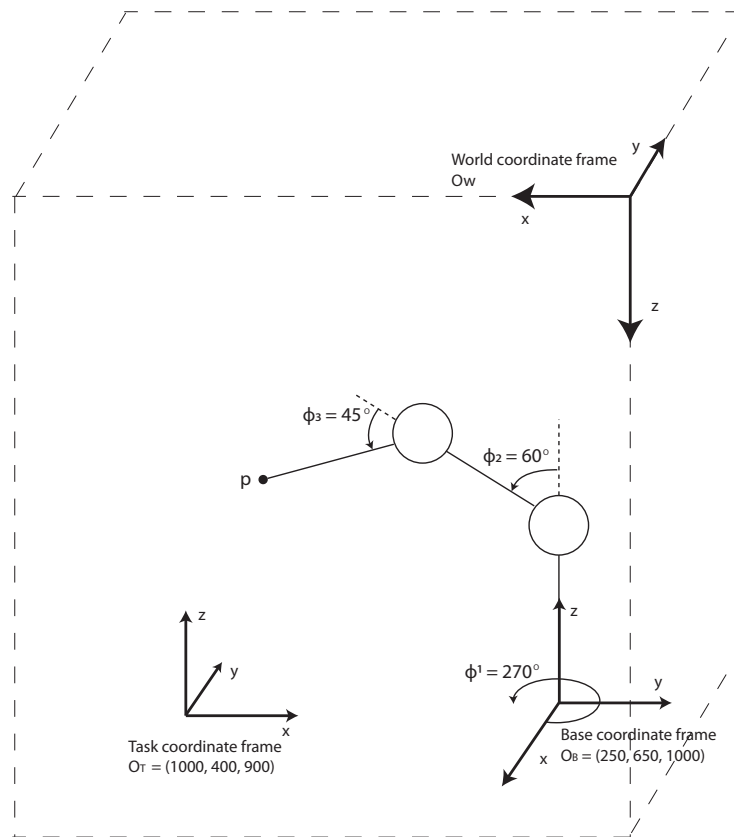

Figure 4: Robot with respect to World and Task frame

DH-convention. Link lengths in the figure are not proportional to the real robot.

Use the following dimensions in your calculation:

- $L1 = 100.9mm$
- $L2 = 222.1mm$
- $L3 = 136.2mm$

Task Find p^T , the coordinates of point p given in task coordinate frame $\{T\}$.

HINT Use your calculations from task 1 and 2c to find the answer.

Task 4

- a) Derive the inverse kinematic equations for the simplified robot, and show the different steps.
- b) How many solutions exist for the joint angles given an arbitrary position of the tip of link 3?

NOTE: We advise students to do this task by hand first. Similar assignments can, and have, be given on the exam and an understanding of how to calculate the inverse kinematic by hand is very valuable!

Requirements:

Each student must hand in their own assignment, and you are required to have read the following declaration to student submissions at the department of informatics: <http://www.ifl.uio.no/studinf/skjemaer/declaration.pdf>

IMPORTANT: Name the pdf file: “inf3480-oblig1-*your_username.pdf*”.

Submit your assignment at <https://devilry.ifl.uio.no>.

Your submission must include:

- A pdf-document with answers to the questions.
- The two illustrations asked for in question 2a and 2b

If you have used MATLAB or other tools for computing an answer, your solution and approach must be illustrated and explained thoroughly in the pdf file.

The files containing the code must also be named and delivered.

Deadline: Wednesday, March 1st 2017

You can use the slack channel *assignment 1* for general questions about the assignment, and the channels *forward kinematics* and *inverse kinematics* for discussion. Do not hesitate to contact us if you have any further questions.

Eirik Kvalheim - eirikval@mail.uio.no

Sadegh Hosseinpoor - sadeghh@mail.uio.no

Marius Wilhelm Olstad - mariuwo@mail.uio.no

Aryan Esfandiari - aryane@mail.uio.no