

INF3510 Information Security

Lecture 10: Communications Security

Audun Jøsang

University of Oslo

Spring 2017



Outline

- Network security concepts
 - Communication security
 - Perimeter security
- Protocol architecture and security services
- Example security protocols
 - Transport Layer Security (TLS)
 - IP Layer Security (IPSec)
- VPN – Virtual Private Network

Network Security Concepts

Assumes that each organisation owns a network

- Wants to protect own local network
- Wants to protect communication with other networks

Network Security: two main areas

- **Communication Security:** Protection of data transmitted across networks between organisations and end users
 - Topic for this lecture
- **Perimeter Security:** Protection of an organization's network from unauthorized access
 - Topic for next lecture

Communication Security Analogy

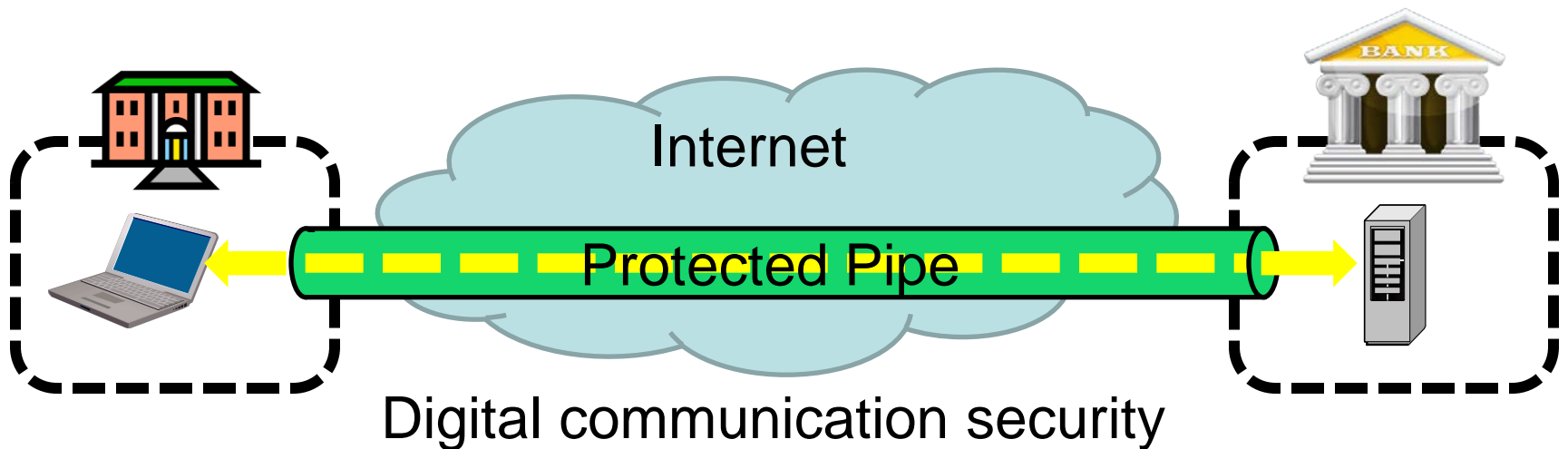

Communication Protocol Architecture

- Layered structure of hardware and software that supports the exchange of data between systems
- Each protocol consists of a set of rules for exchanging messages, i.e. “the protocol”.
- Two standards:
 - OSI Reference model
 - Never lived up to early promises
 - TCP/IP protocol suite
 - Most widely used

OSI – Open Systems Interconnection

- Developed by the International Organization for Standardization (ISO)
- A layer model of 7 layers
- Each layer performs a subset of the required communication functions
- Each layer relies on the next lower layer to perform more primitive functions
- Each layer provides services to the next higher layer
- Changes in one layer should not require changes in other layers

The OSI Protocol Stack

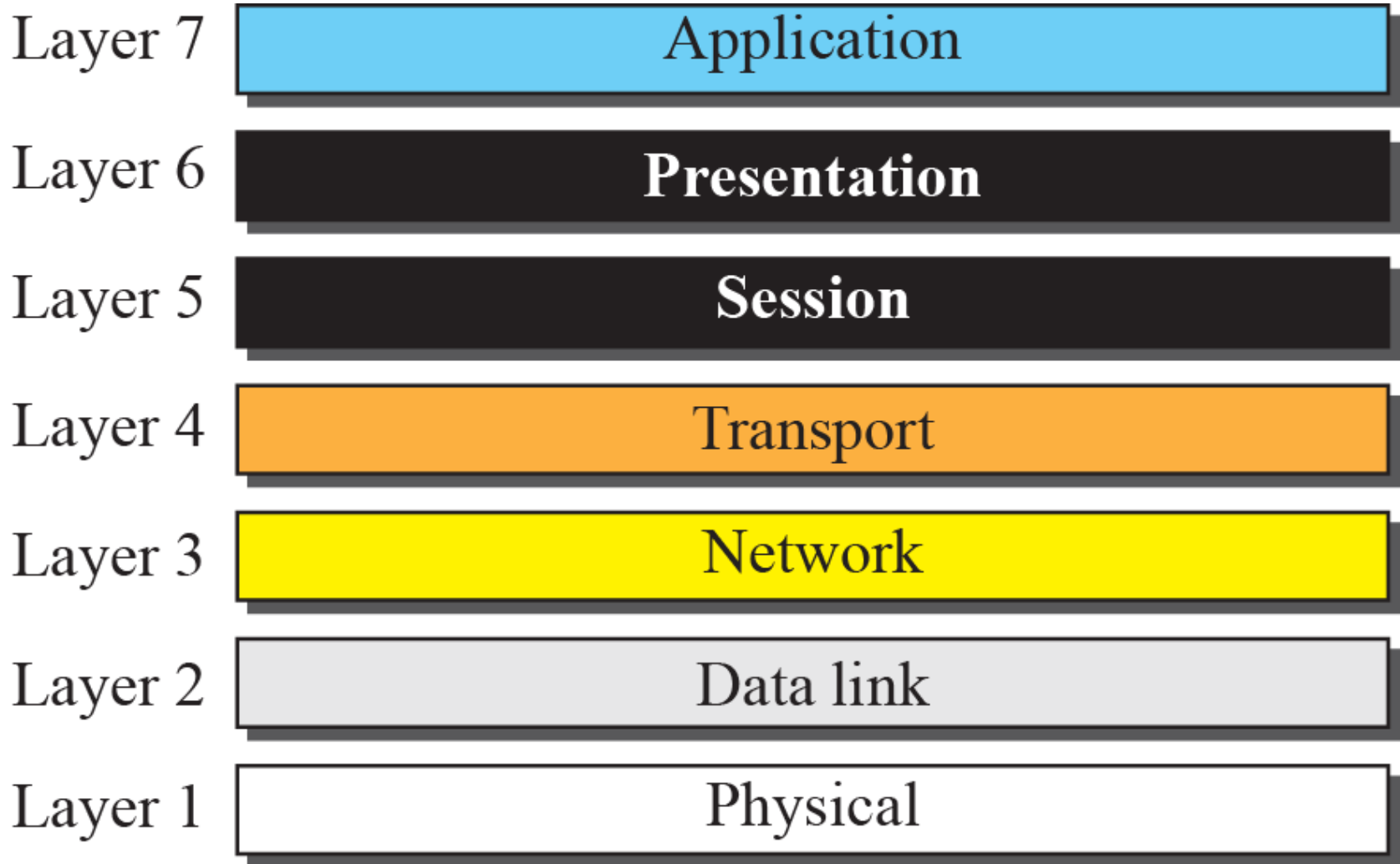

Communication across OSI

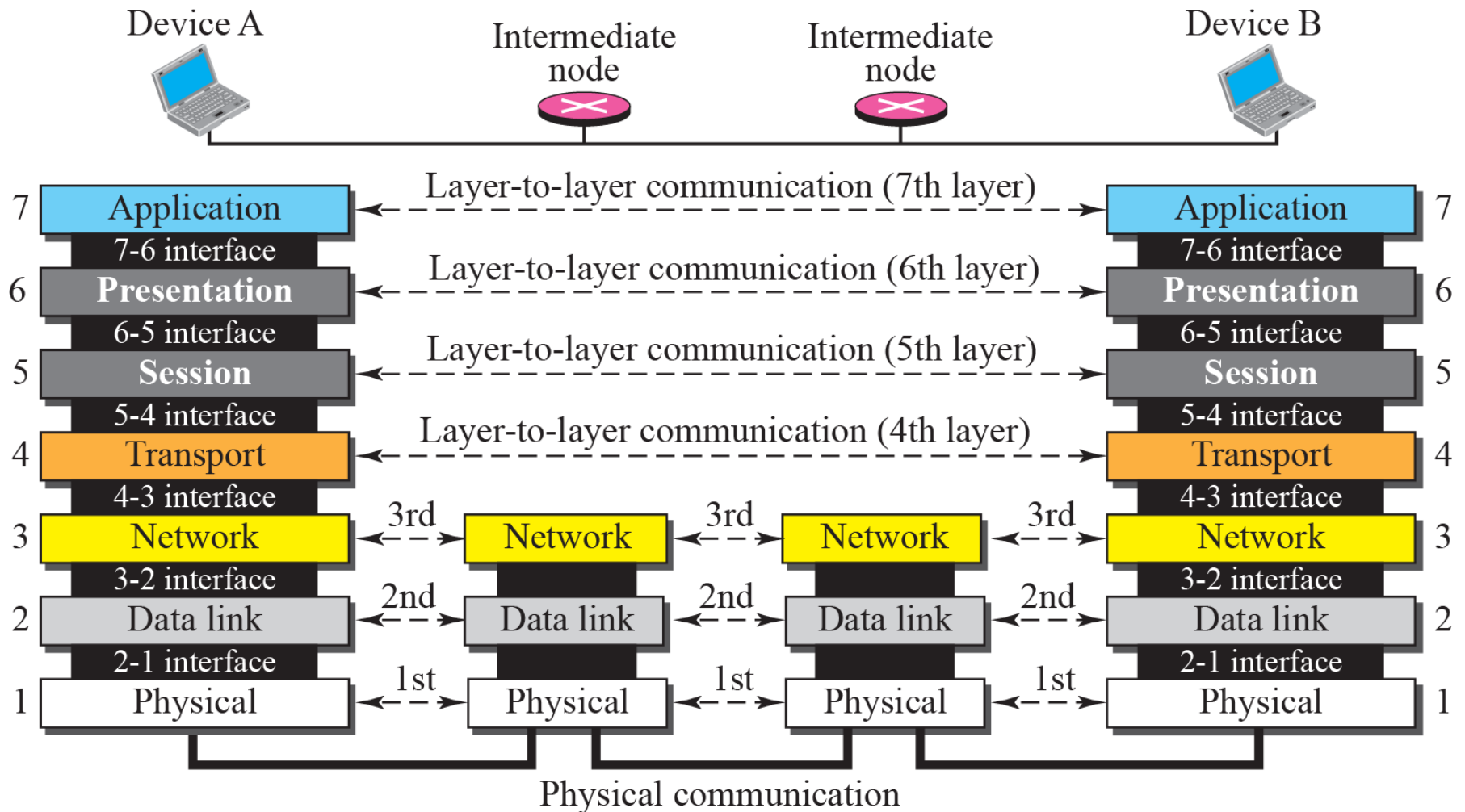

TCP/IP Protocol Architecture

- Developed by the US Defense Advanced Research Project Agency (DARPA) for its packet switched network (ARPANET)
- Used by the global Internet
- No official model, but it's a working one.
 - Application layer
 - Host to host or transport layer
 - Internet layer
 - Network access layer
 - Physical layer

OSI model vs. TCP/IP model (The Internet)

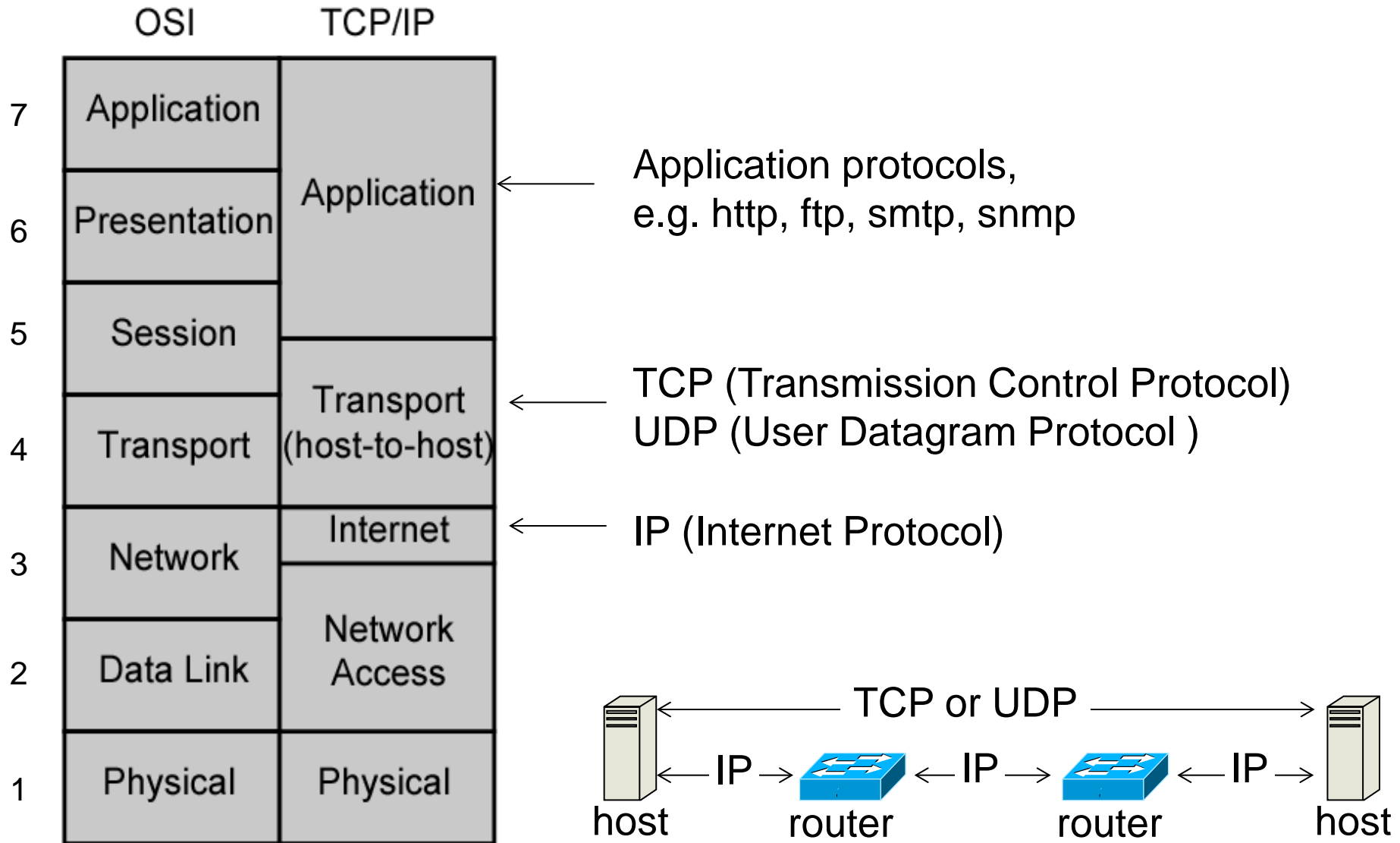

Security Protocols

- Many different security protocols have been specified and implemented for different purposes
 - Authentication, integrity, confidentiality
 - Key establishment/exchange
 - E-Voting
 - Secret sharing
 - etc.
- Protocols are surprisingly difficult to get right!
 - Many vulnerabilities are discovered years later
 - ... some are never discovered (or maybe only by the attackers)

Security Protocols Overview

- This lecture discusses the operation of two network-related protocols that are in common use.
 - **Transport Layer Security (TLS):**
Used extensively on the web and is often referred to in privacy policies as a means of providing confidential web connections.
 - **IP Security (IPSec):**
Provides security services at the IP level and is used to provide Virtual Private Network (VPN) services.

Transport Layer Security

TLS/SSL

SSL/TLS: History

- 1994: Netscape Communications developed the network authentication protocol Secure Sockets Layer, SSLv2.
 - Badly broken
- 1995: Netscape release their own improvements SSLv3.
 - Widely used for many years.
- 1996: SSLv3 was submitted to the IETF as an Internet draft, and an IETF working group was formed to develop a recommendation.
- In January 1999, [RFC 2246](#) was issued by the IETF, Transport Layer Security Protocol: TLS 1.0
 - Similar to, but incompatible with SSLv3
 - Currently TLS 1.2 (2008) (allows backwards compatibility with SSL)
 - Draft TLS 1.3 (2016) (totally bans SSL)
 - Firefox browser enabled TLS 1.3 by default in February 2017^[1]

TLS:

Overview

- TLS is a cryptographic services protocol based on the Browser PKI, and is commonly used on the Internet.
 - Each server has a server certificate and private key installed
 - Allows browsers to establish secure sessions with web servers.
- Port 443 is reserved for HTTP over TLS/SSL and the protocol https is used with this port.
 - `http://www.xxx.com` implies using standard HTTP using port 80.
 - `https://www.xxx.com` implies HTTP over TLS/SSL with port 443.

TLS: Layer 4 Security

TLS operates
at Layer 4

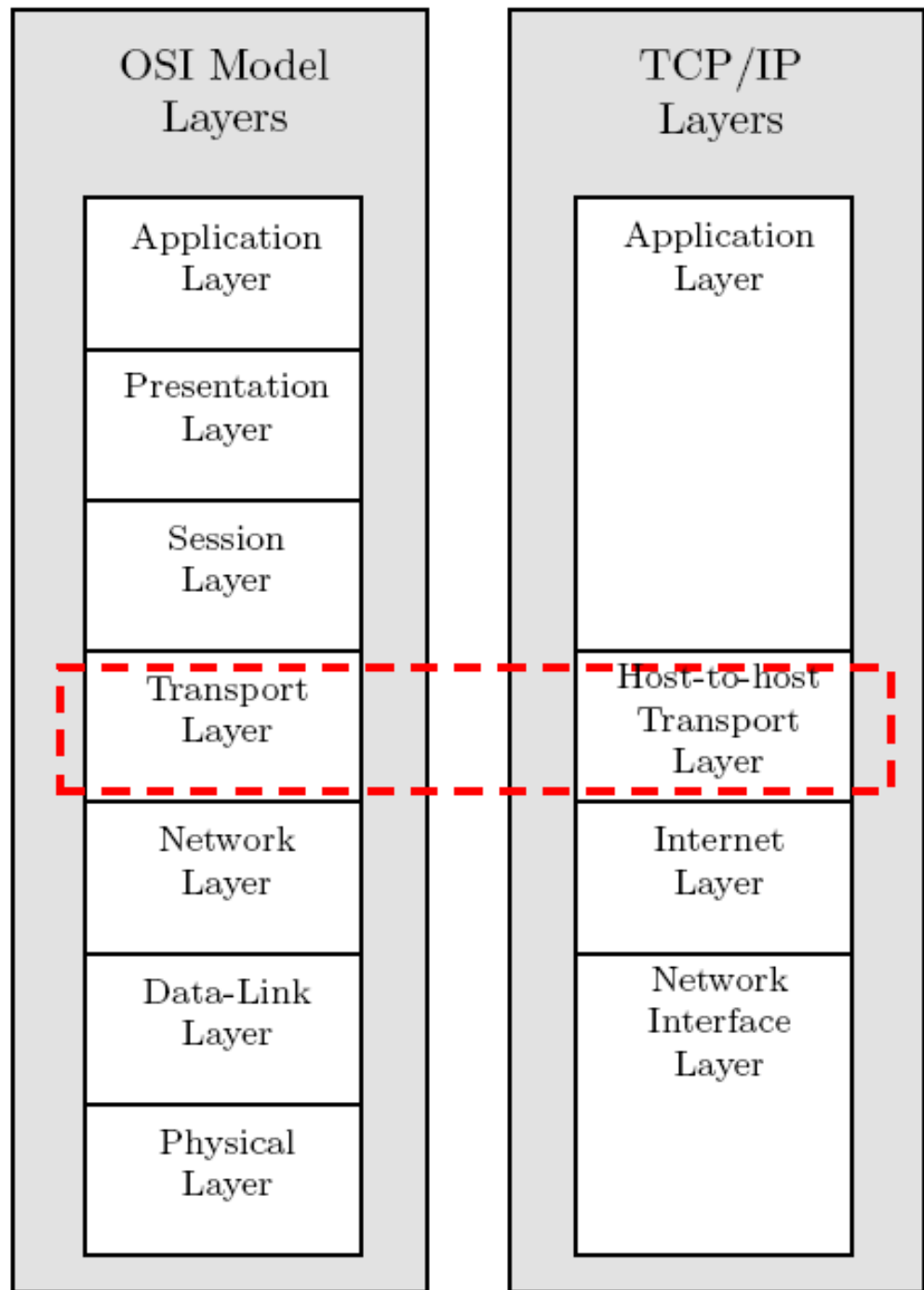

TLS:

Architecture Overview

- Designed to provide secure reliable end-to-end services over TCP.
- Consists of 3 higher level protocols:
 - TLS Handshake Protocol
 - TLS Alert Protocol
 - TLS Change Cipher Spec Protocol
- The TLS Record Protocol provides the practical encryption and integrity services to various application protocols.

TLS: Protocol Stack

TLS Handshake Protocol	TLS Change Cipher Suite Protocol	TLS Alert Protocol	Application Protocol (HTTP)
TLS Record Protocol			
TCP			
IP			

TLS:

Handshake Protocol

- The handshake protocol
 - Negotiates the encryption to be used
 - Establishes a shared session key
 - Authenticates the server
 - Authenticates the client (optional)
 - Completes the session establishment
- After the handshake, application data is transmitted securely
- Several variations of the handshake exist
 - RSA variants
 - Diffie-Hellman variants

TLS: Handshake

Four phases

- Phase 1: Initiates the logical connection and establishes its security capabilities
- Phases 2 and 3: Performs key exchange. The messages and message content used in this phase depends on the handshake variant negotiated in phase 1.
- Phase 4: Completes the setting up of a secure connection.

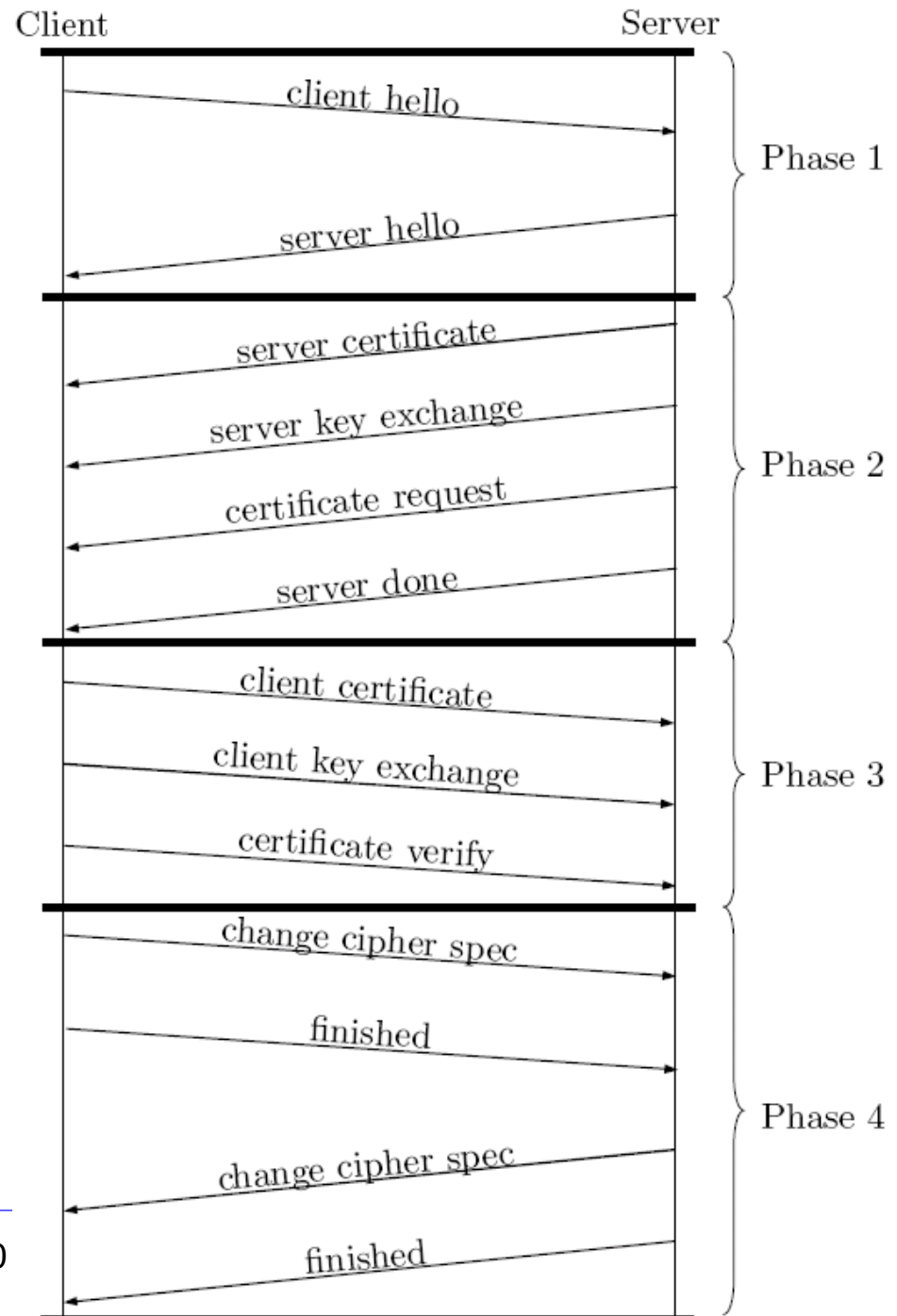

Diagram TLS: Simplified RSA-based Handshake

Client



Server



Supported crypto algorithms and protocol versions

Secret material encrypted with server pub. key

Common protocol, Common algorithm, Server certificate

Client Hello

Server Hello

Client Key Exchange

Client and Server generate session key from secret material

Go to crypto with common algorithm and session key

Go to crypto with common algorithm and session key

Change Cipher Suite

Change Cipher Suite

Continues with TLS Record protocol encrypted with session key

TLS: Elements of Handshake

- **Client hello**
 - Advertises available cipher suites (e.g. RSA, AES, SHA256)
- **Server hello**
 - Returns the selected cipher suite
 - Server adapts to client capabilities
- **RSA and Server Certificate**
 - X.509 digital certificate sent to client, assumes RSA algorithm
 - Client verifies the certificate including that the certificate signer is in its acceptable Certificate Authority (CA) list. Now the client has the server's certified public key.
- **RSA and Client Certificate**
 - Optionally, the client can send its X.509 certificate to server, in order to provide mutual authentication, assumes RSA algorithm
- **Anonymous Diffie-Hellman**
 - Optionally, the client and server can establish session key using the Diffie-Hellman algorithm

TLS:

Record Protocol Overview

- Provides two services for SSL connections.
 - Message Confidentiality:
 - Ensure that the message contents cannot be read in transit.
 - The Handshake Protocol establishes a symmetric key used to encrypt SSL payloads.
 - Message Integrity:
 - Ensure that the receiver can detect if a message is modified in transmission.
 - The Handshake Protocol establishes a shared secret key used to construct a MAC.

TLS: Record Protocol Operation

- **Fragmentation:**
 - Each application layer message is fragmented into blocks of 214 bytes or less.
- **Compression:**
 - Optionally applied.
 - SSL v3 & TLS – default compression algorithm is null
- **Add MAC:**
 - Calculates a MAC over the compressed data using a MAC secret from the connection state.
- **Encrypt:**
 - Compressed data plus MAC are encrypted with symmetric cipher.
 - Permitted ciphers include AES, IDEA, DES, 3DES, RC4
 - For block ciphers, padding is applied after the MAC to make a multiple of the cipher's block size.

SSL/TLS Challenges

- Higher layers should not be overly reliant on SSL/TLS.
- Many vulnerabilities exist for SSL/TLS.
 - People are easily tricked
 - Changing between http and https causes vulnerability to SSL stripping attacks
 - SSL/TLS only as secure as the cryptographic algorithms used in handshake protocol: hashing, symmetric and asymmetric crypto.
- Relies on Browser PKI which has many security issues
 - Fake server certificates difficult to detect
 - Fake root server certificates can be embedded in platform, see e.g. Lenovo Komodia advare scam

SSL Stripping Attack

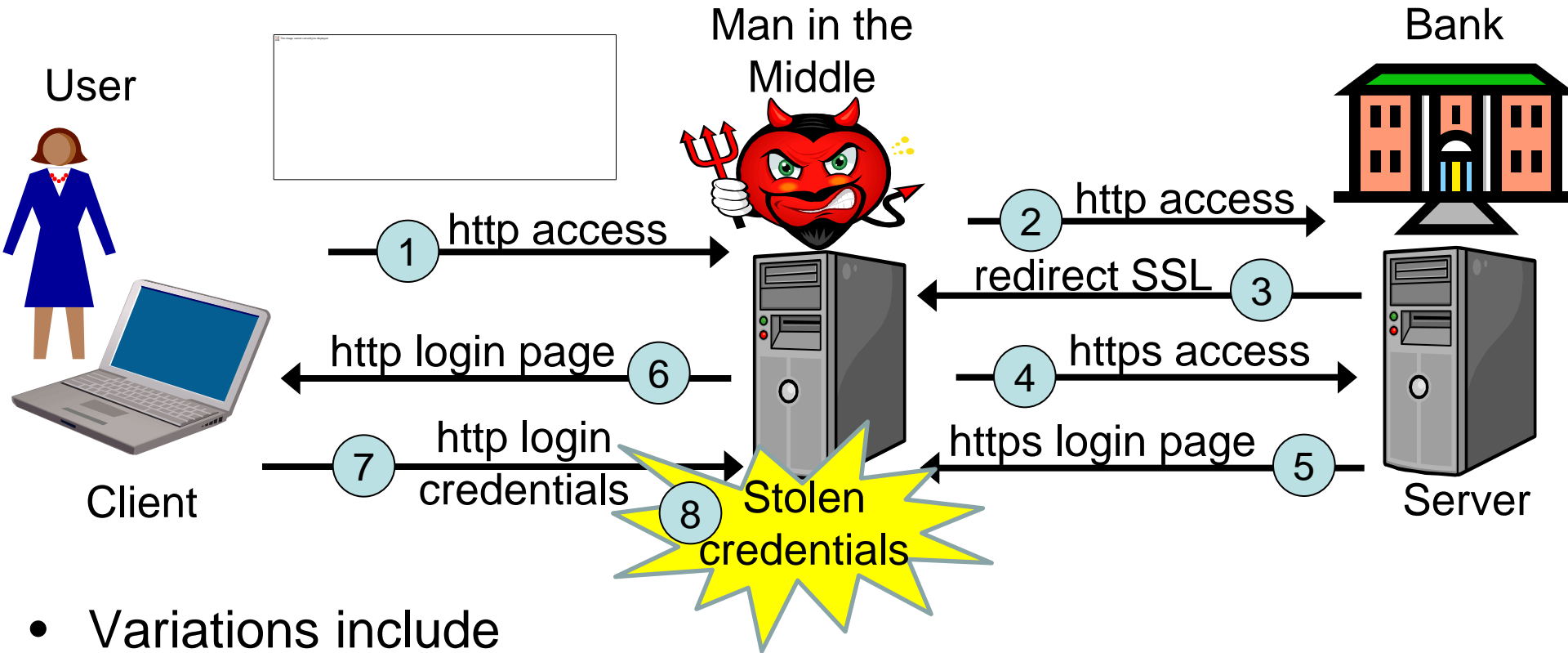

- Variations include

- MitM server can connect to client over https in msg (6) with server certificate that has similar domain name as real server.
- Attacker can leave the connection after stealing credentials, then the client connects directly to real server with https

HSTS – HTTP Strict Transport Security

Preventing SSL Stripping

- A secure server can instruct browsers to only use https
- When requesting website that uses HSTS, the browser automatically forces connect with https.
- Users are not able to override policy
- Two ways of specifying HSTS websites
 - List of HSTS websites can be preloaded into browsers
 - HSTS policy initially specified over a https connection
 - HSTS policy can be changed over a https connection
- Disadvantages
 - HSTS websites can not use both http and https
 - Difficult for a website to stop using https
 - Can cause denial of service, e.g. no fallback to http in case of expired server certificate

Preventing SSL Stripping with HSTS

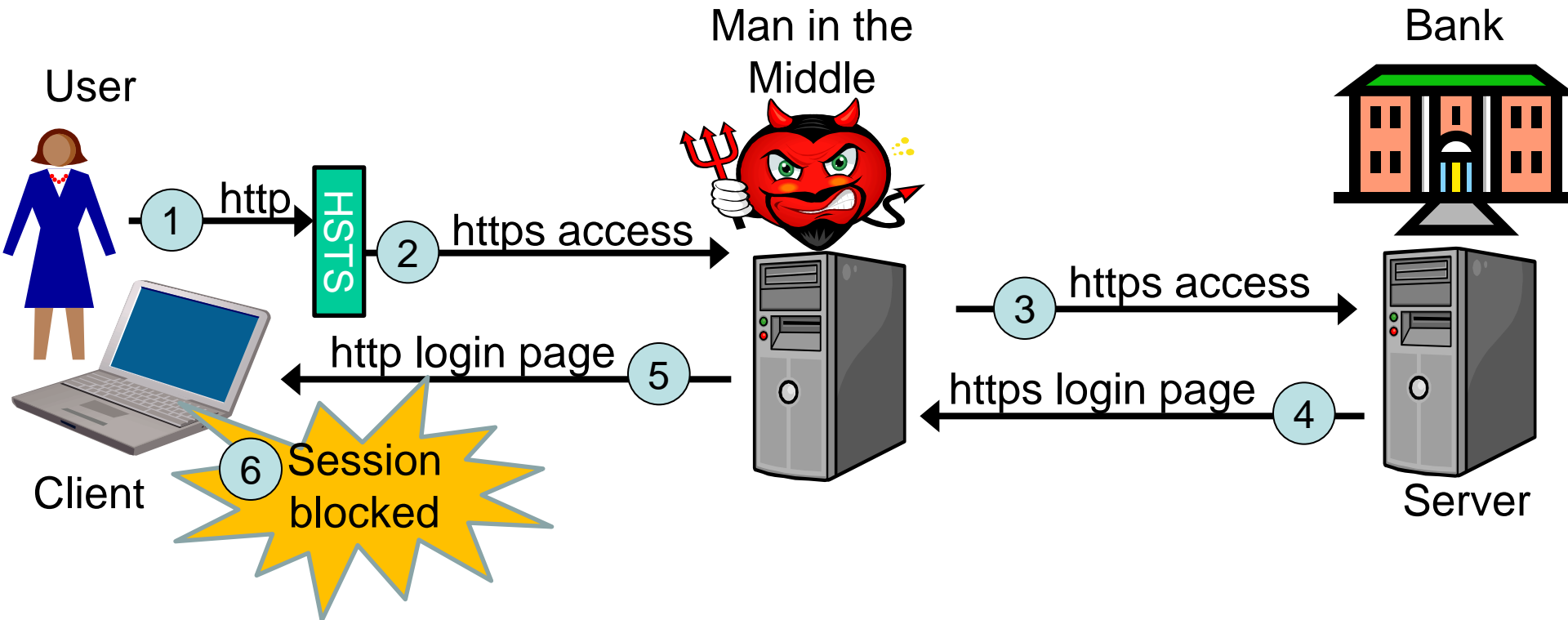

- Limitation of HSTS:
 - Requires first visit to secure website to set HSTS policy in browser
- Can be solved by browser having preloaded list of HSTS websites
- Browsers would be vulnerable if attacker could delete HSTS cache

Server Authentication Modalities

Syntactic entity authentication:

- Verification that the identity of the remote entity is as claimed.
- Does not provide any meaningful security because of indifference to the owner entity of authenticated identity.

Semantic entity authentication:

- Verification that the identity of the remote entity is as claimed, combined with a policy for authenticated entities.
- Automated control of policy, e.g. with white-list of domains.

Cognitive entity authentication:

- Verification by a cognitive entity (human) that the identity of the remote entity is as claimed, and a conscious decision that the identity is acceptable and as expected.
- Manual control of policy, e.g. by inspecting certificates.

Meaningless Server Authentication when only applying syntactic authentication

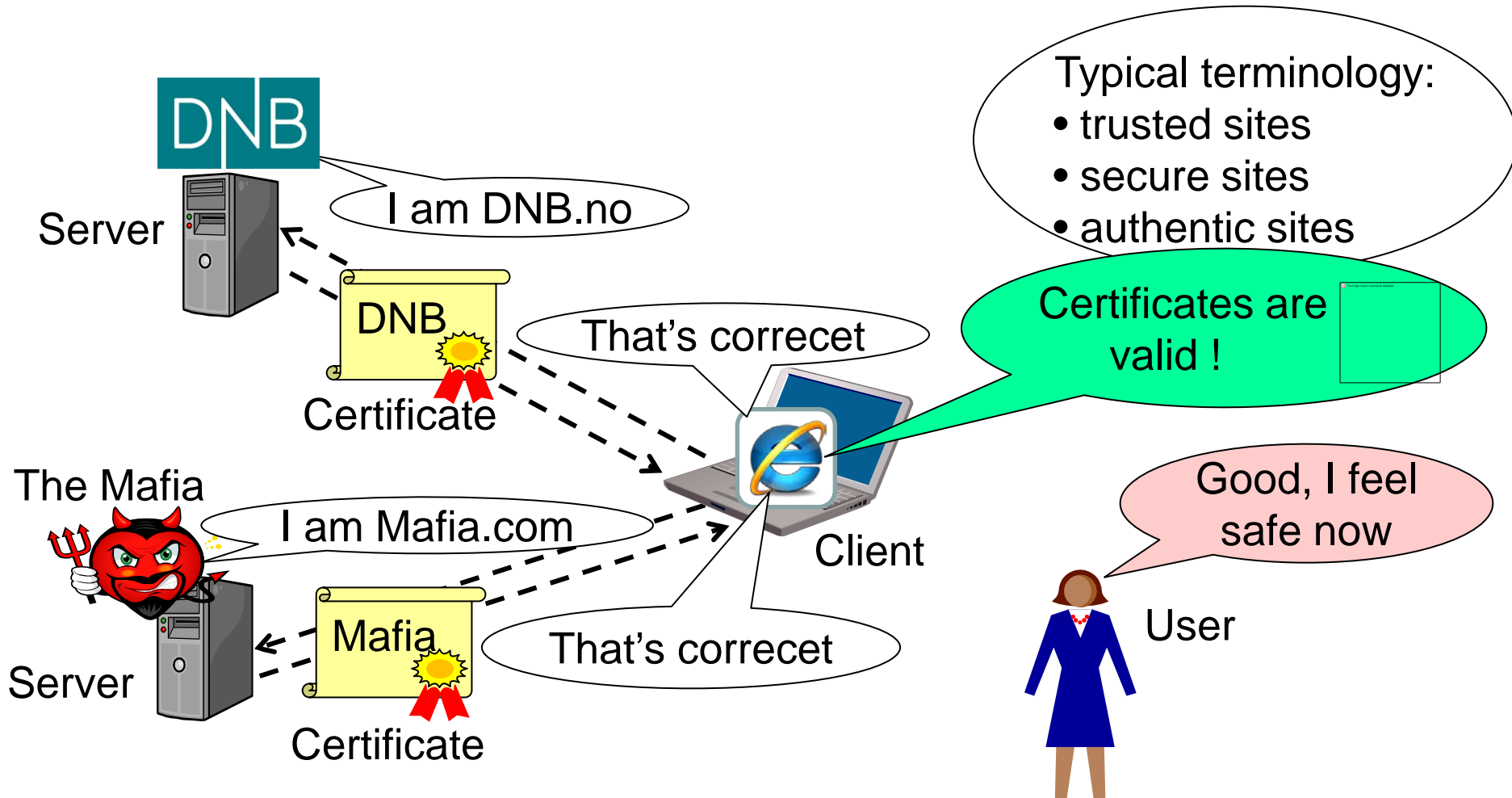

Phishing and failed authentication

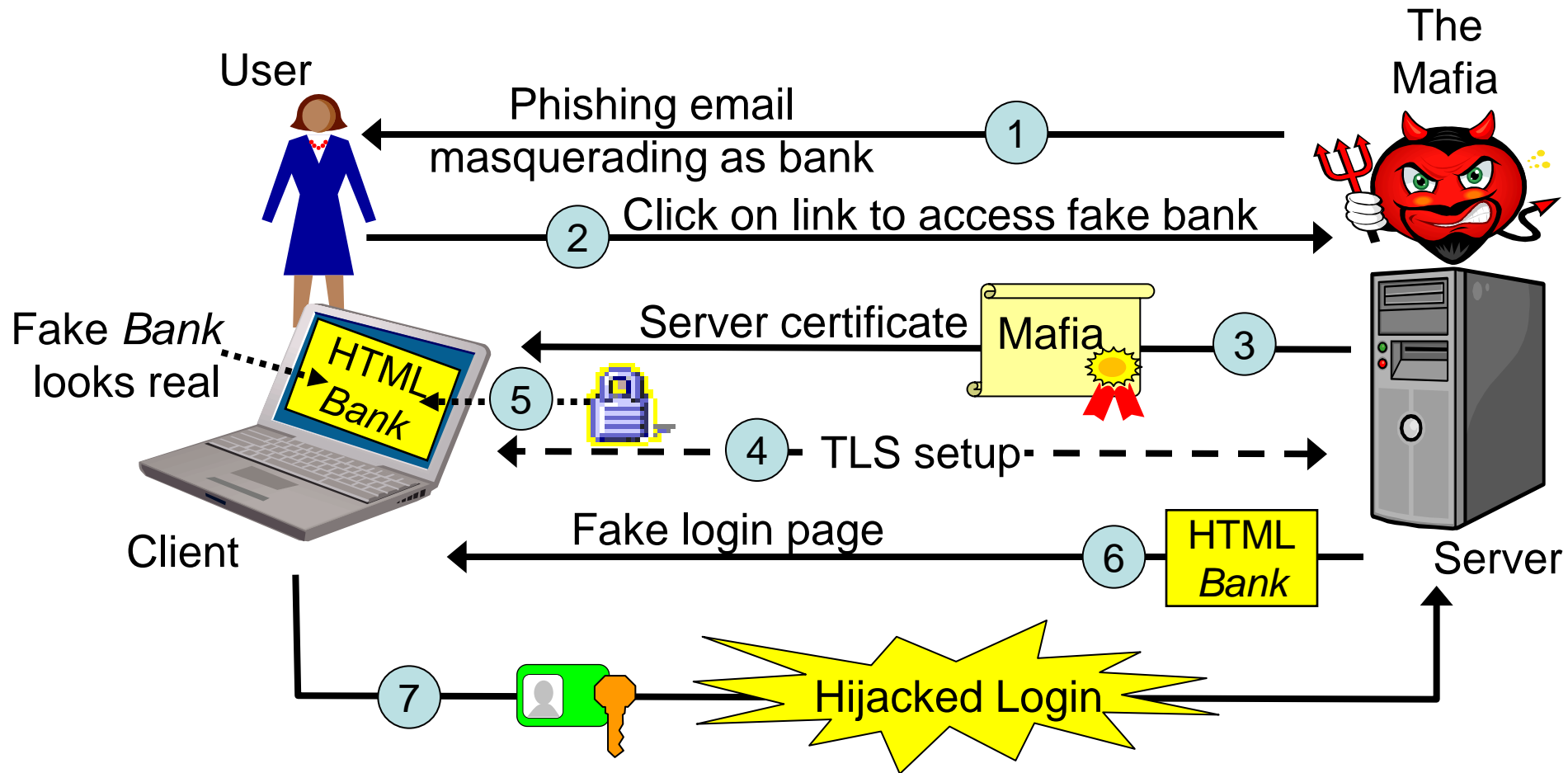

IP Layer Security

IPSec & Virtual Private Networks

IPSec:

Introduction

- Internet Protocol security (IPSec) is standard for secure communications over Internet Protocol (IP) networks, through the use of cryptographic security services.
- Uses encryption, authentication and key management algorithms
- Based on an end-to-end security model at the IP level
- Provides a security architecture for both IPv4 and IPv6
 - Mandatory for IPv6
 - Optional for IPv4
- Requires operating system support, not application support.

Layer 3 Security

IP Sec Operation →

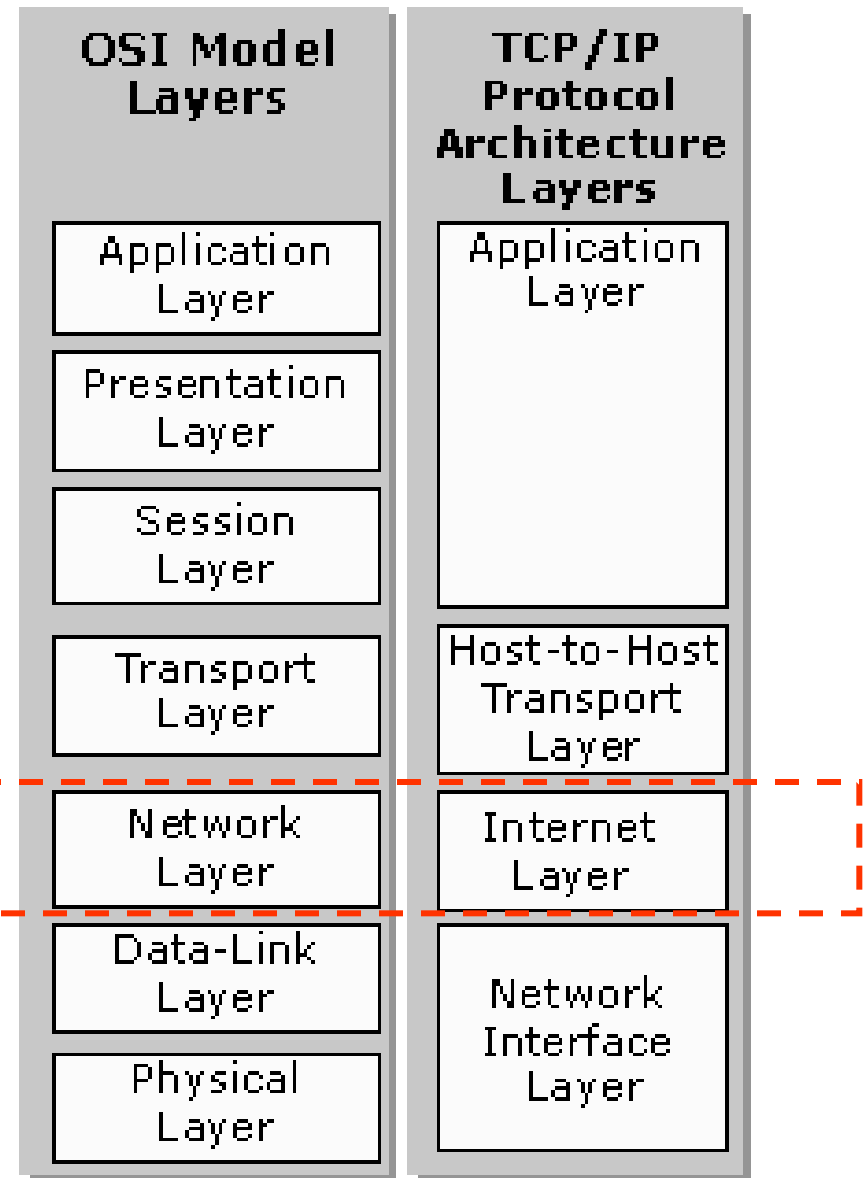

IPSec: Security Services

- **Message Confidentiality.**
 - Protects against unauthorized data disclosure.
 - Accomplished by the use of encryption mechanisms.
- **Message Integrity.**
 - IPsec can determine if data has been changed (intentionally or unintentionally) during transit.
 - Integrity of data can be assured by using a MAC.
- **Traffic Analysis Protection.**
 - A person monitoring network traffic cannot know which parties are communicating, how often, or how much data is being sent.
 - Provided by concealing IP datagram details such as source and destination address.

IPSec:

Security Services

- **Message Replay Protection.**
 - The same data is not delivered multiple times, and data is not delivered grossly out of order.
 - However, IPsec does not ensure that data is delivered in the exact order in which it is sent.
- **Peer Authentication.**
 - Each IPsec endpoint confirms the identity of the other IPsec endpoint with which it wishes to communicate.
 - Ensures that network traffic is being sent from the expected host.
- **Network Access Control.**
 - Filtering can ensure users only have access to certain network resources and can only use certain types of network traffic.

IPSec:

Common Architectures

- Gateway-to-Gateway Architecture
- Host-to-Gateway Architecture
- Host-to-Host Architecture

IPSec: Gateway-to-Gateway Architecture

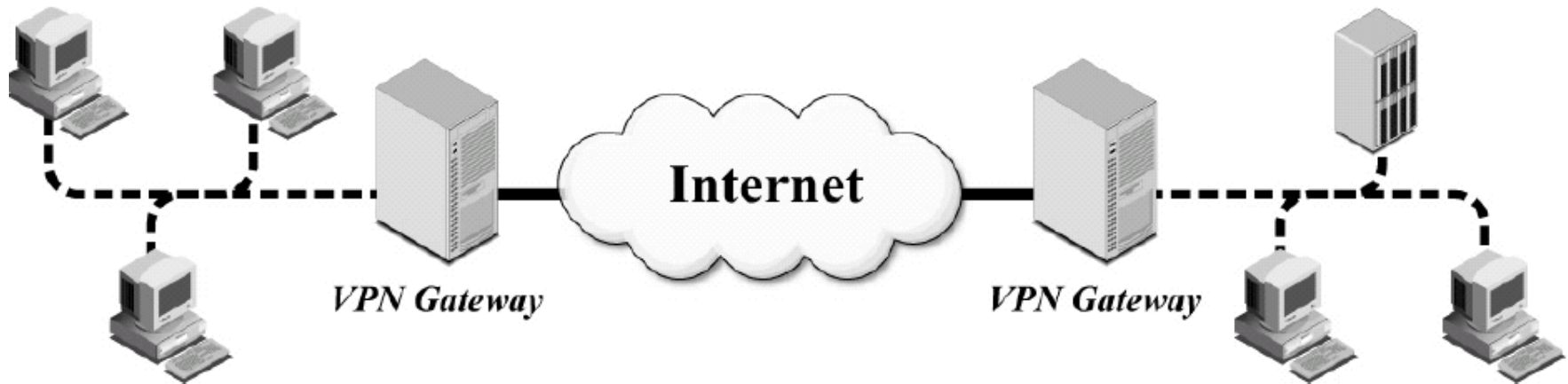

Source: NIST Special Publication 800-77

IPSec: Host-to-Gateway Architecture

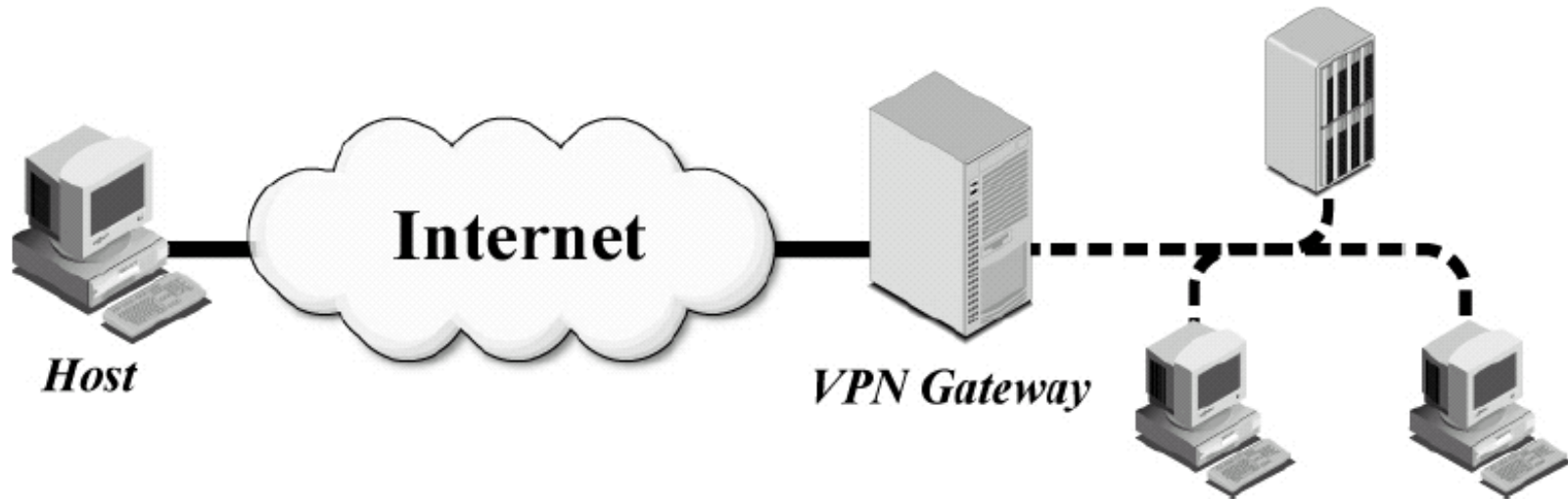

Source: NIST Special Publication 800-77

IPSec: Host-to-Host Architecture

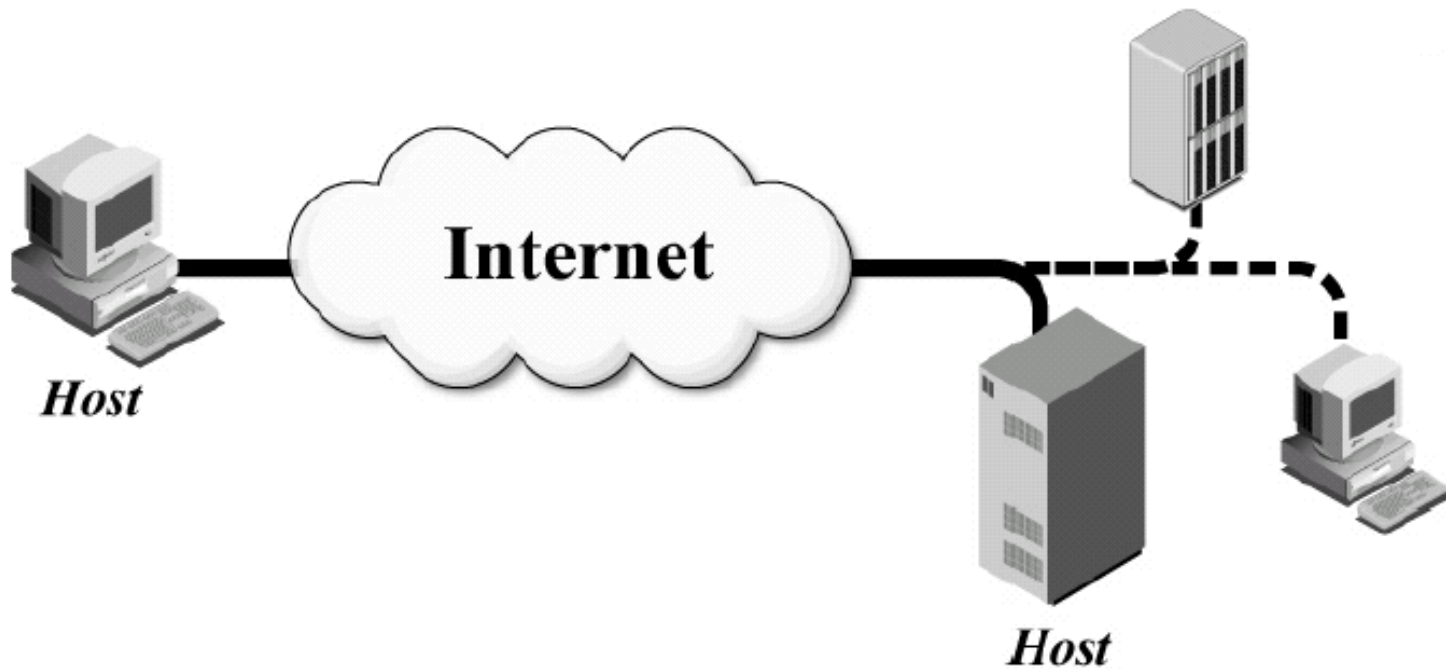

Source: NIST Special Publication 800-77

IPSec:

Protocols Types

- Encapsulating Security Payload (ESP)
 - Confidentiality, authentication, integrity and replay protection
- Authentication Header (AH)
 - Authentication, integrity and replay protection. However there is no confidentiality
- Internet Key Exchange (IKE)
 - negotiate, create, and manage security associations
- A connection consists of two SA (Security Associations)
 - One SA for each directions
 - Each SA is described by a set of parameters

IPSec:

Modes of operation

- Each protocol (ESP or AH) can operate in transport or tunnel mode.
- **Transport mode:**
 - Operates primarily on the payload (data) of the original packet.
 - Generally only used in host-to-host architectures.
- **Tunnel mode:**
 - Original packet encapsulated into a new one, payload is original packet.
 - Typical use is gateway-to-gateway and host-to-gateway architectures.

Transport Mode ESP

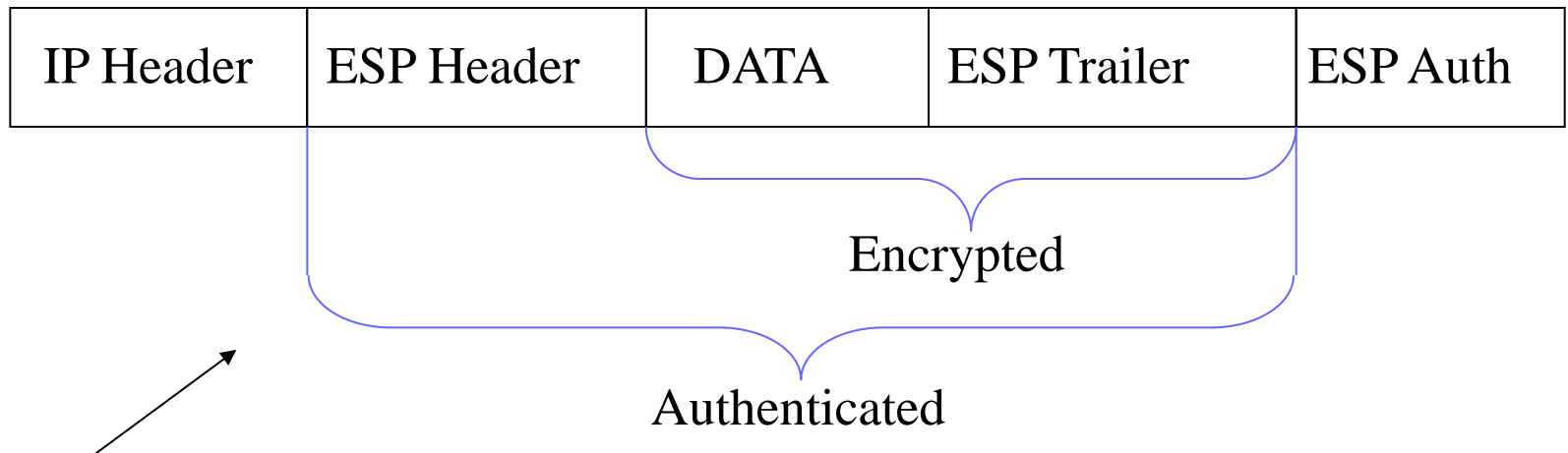
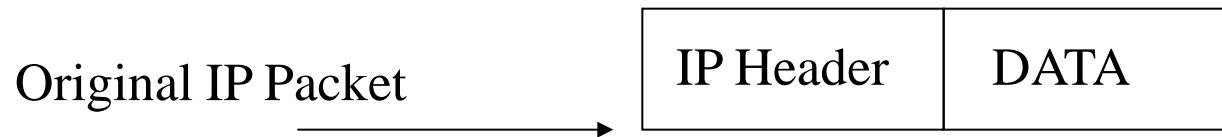

Original IP Packet protected by Transport-ESP

IPSec - ESP in Transport Mode: Outbound Packet Processing

- The data after the original IP header is padded by adding an ESP trailer and the result is then encrypted using the symmetric cipher and key in the SA.
- An ESP header is prepended.
- If an SA uses the authentication service, an ESP MAC is calculated over the data prepared so far and appended.
- The original IP header is prepended.
- However, some fields in the original IP header must be changed. For example,
 - Protocol field changes from TCP to ESP.
 - Total Length field must be changed to reflect the addition of the AH header.
 - Checksums must be recalculated.

Tunnel Mode ESP

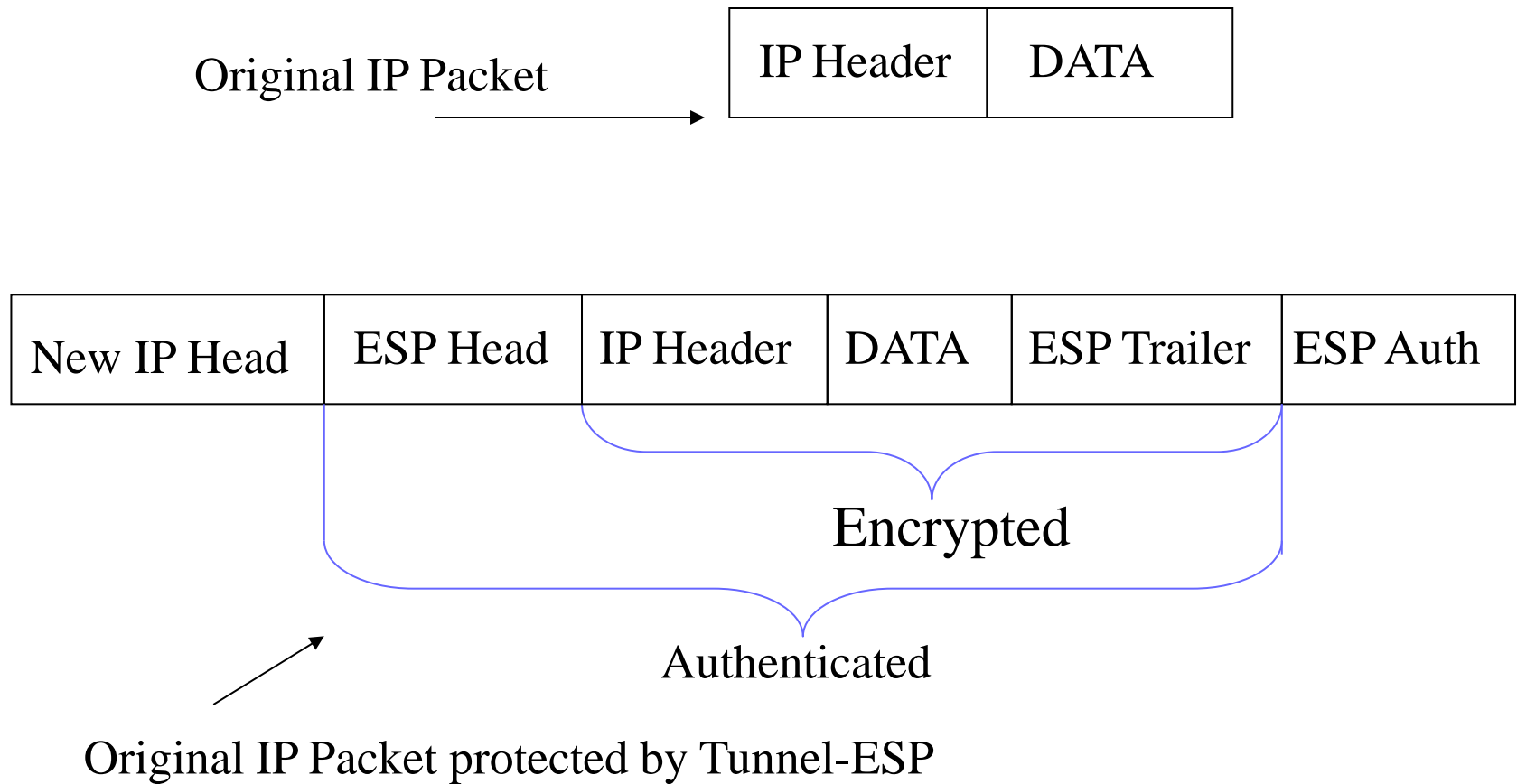

IPSec - ESP in Tunnel Mode: Outbound Packet Processing

- The entire original packet is padded by adding an ESP trailer and the result is then encrypted using the symmetric cipher and key agreed in the SA.
- An ESP header is prepended.
- If an SA uses the authentication service, an ESP MAC is calculated over the data prepared so far and appended.
- A new 'outer' IP header is prepended.
 - The 'inner' IP header of the original IP packet carries the ultimate source and destination addresses.
 - The 'outer' IP header may contain distinct IP addresses such as addresses of security gateways.
 - The 'outer' IP header Protocol field is set to ESP.

Security Associations

- A security association (SA) contains info needed by an IPSec endpoint to support one end of an IPSec connection.
- Can include cryptographic keys and algorithms, key lifetimes, security parameter index (SPI), and security protocol identifier (ESP or AH).
- The SPI is included in the IPSec header to associate a packet with the appropriate SA.
- Security Associations are simplex
 - need one for each direction of connection
 - stored in a security association database (SAD).
- Key exchange is largely automated after initial manual configuration by administrator prior to connection setup.
- (See ISAKMP, IKE, Oakley, Skeme and SAs)

Risks of using IPSec for VPN

- IPSec typically used for VPN (Virtual Private Networks)
- A VPN client at external location may be connected to the Internet (e.g. from hotel room or café) while at the same time being connected to home network via VPN.
 - VPN gives direct access to resources in home network.
- Internet access from external location may give high exposure to cyber threats
 - No network firewall, no network IDS
- Attacks against the VPN client at external location can directly access the home network through VPN tunnel

Risk of using VPN

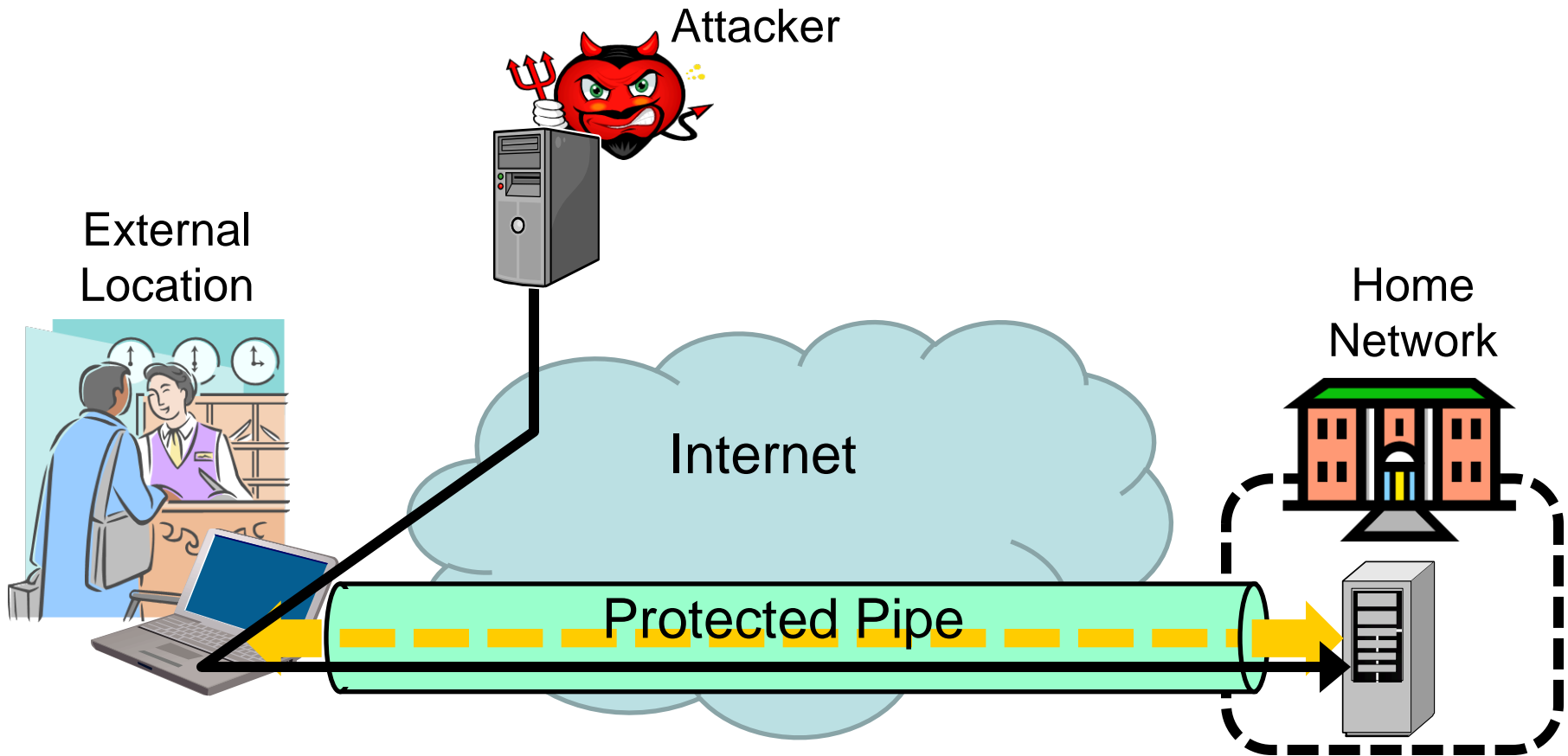

Secure pipe can be attack channel to home network !

Cloud VPN

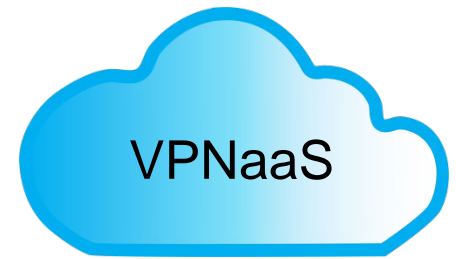

- A cloud-based infrastructure for VPN.
- A.k.a.:
 - Hosted VPN
 - VPNaaS (Virtual Private Network as a Service)
- Cloud VPNs provide security and globally accessible VPN service access without the need for any VPN infrastructure on the user's end.
- The user connects to the cloud VPN through the provider's website or a desktop/mobile app.
- The pricing of cloud VPN is based on pay-per-usage or a flat-fee subscription.
- Disadvantages /risks
 - Cleartext-gap at the VPN provider
 - VPN provider knows Internet usage profile
 - Malicious VPN service?

Cloud VPN Hosted VPN VPNaaS

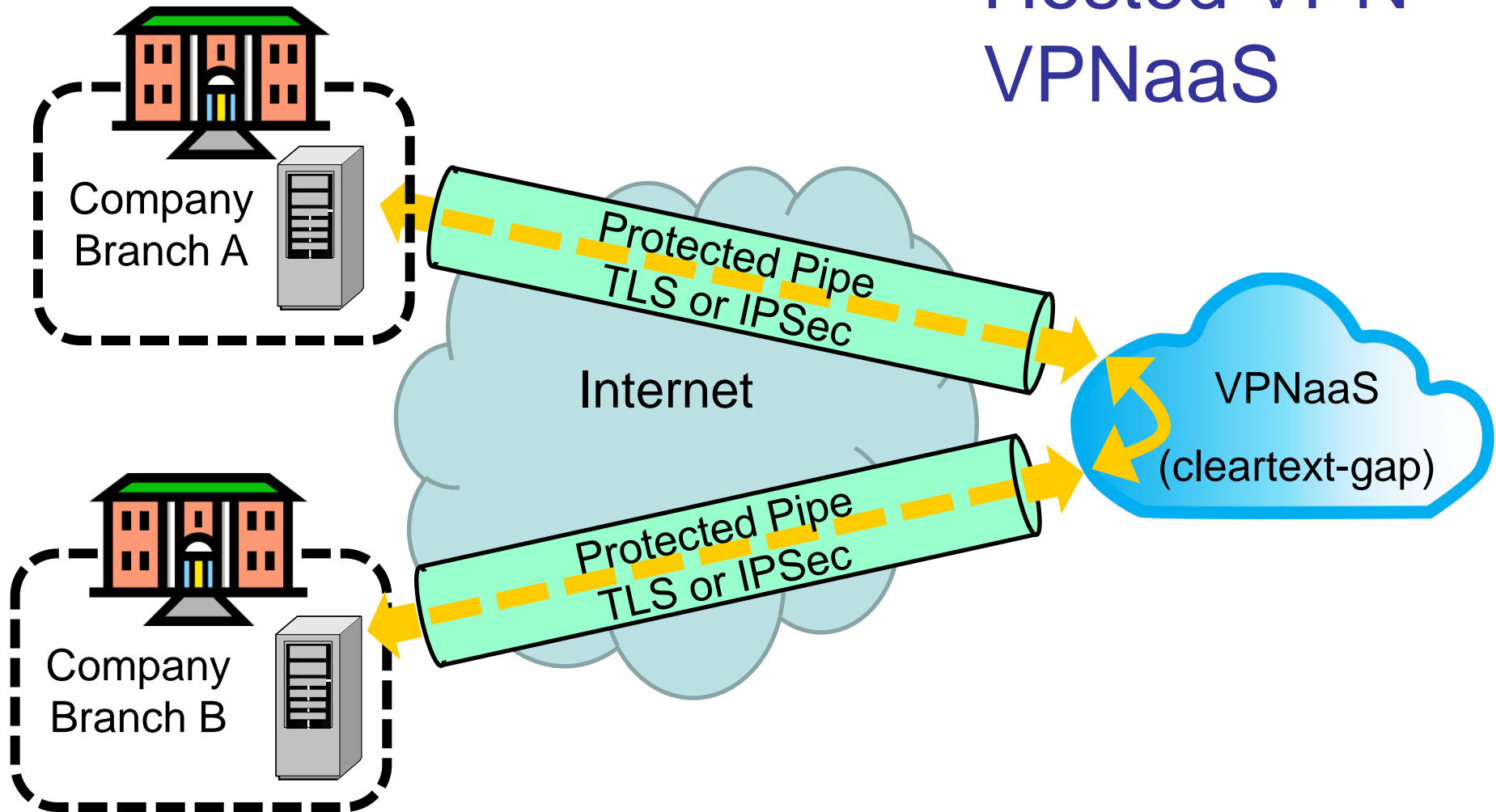

Internet services

VPN Browsing – via VPN Proxy

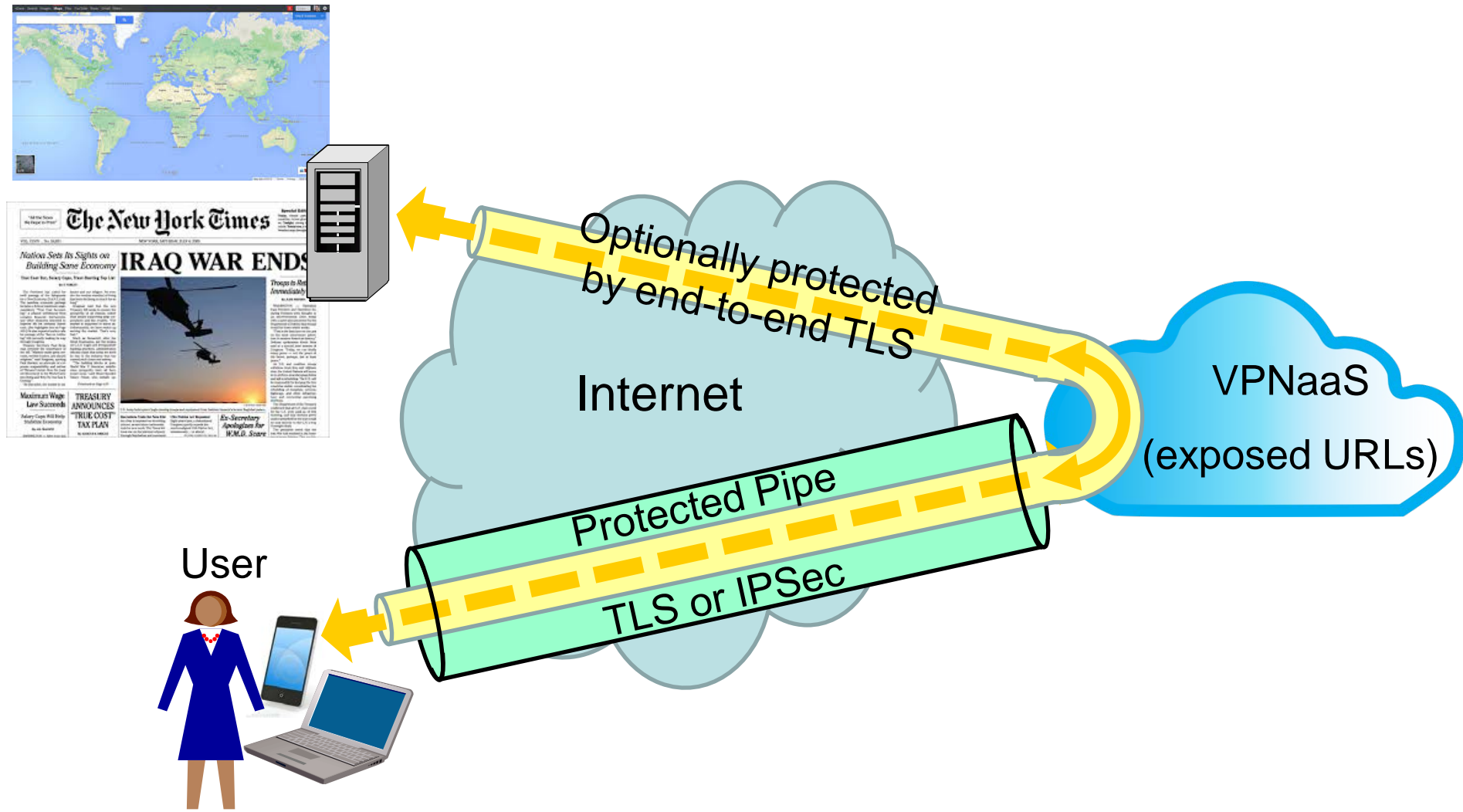

Tor – The Onion Router

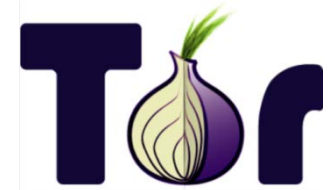

Image courtesy indymedia.de

- An anonymizing routing protocol
- Originally sponsored by the US Naval Research Laboratory
- From 2004 to 2006 was supported by EFF
- Since 2006 independent nonprofit organisation

- Creates a multi-hop proxy circuit through the Internet from client to destination.
- Each hop “wraps” another encryption layer with symmetric keys, thereby hiding the next destination.
- No cleartext-gap, except at the exit-node.
- No node knows end-to-end client-server association
- Full technical details: <http://www.torproject.org/tor-design.pdf>

How Tor Works: 1



Image courtesy torproject.org

How Tor Works: 2

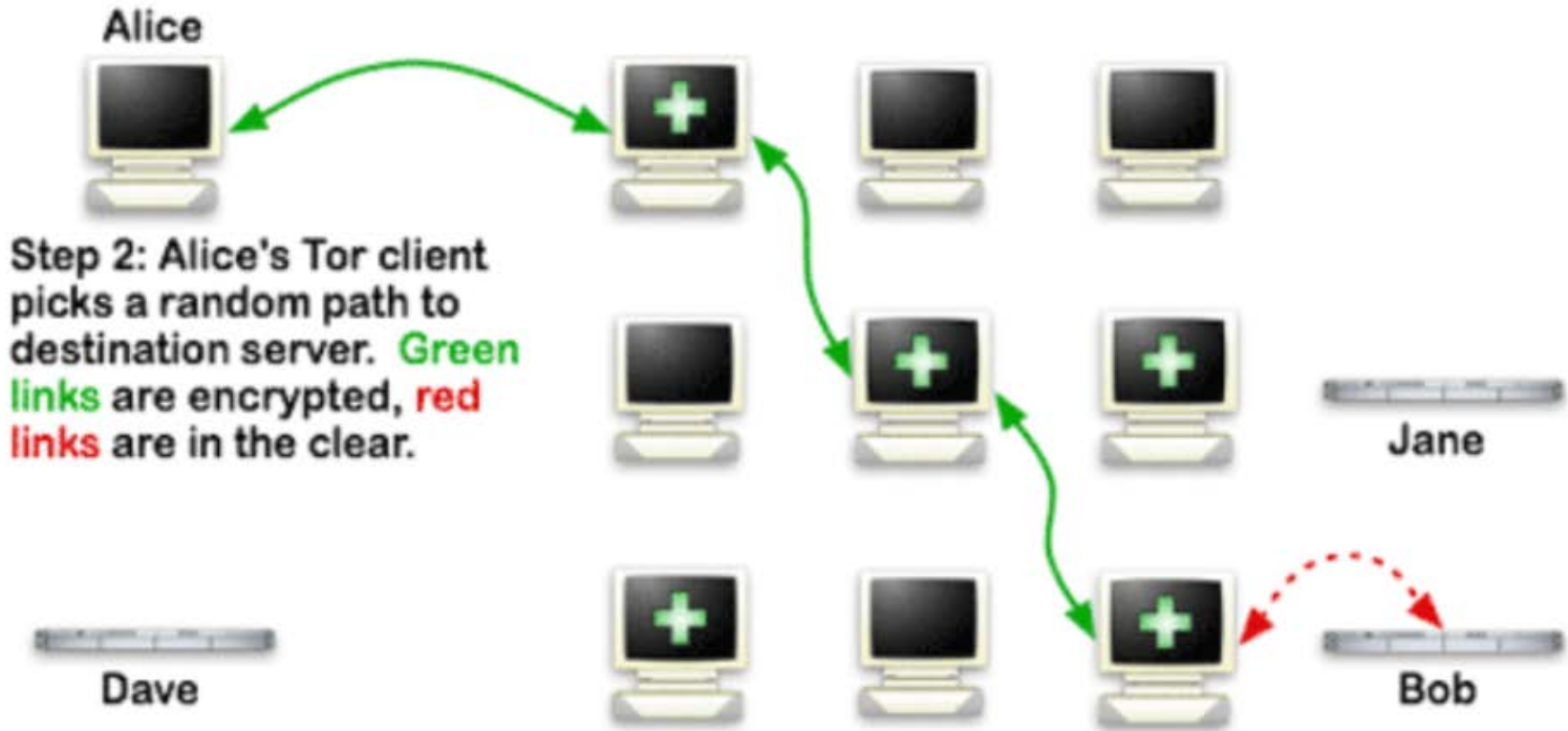

Image courtesy torproject.org

How Tor Works: 3



Alice



Step 3: If the user wants access to another site, Alice's Tor client selects a second random path. Again, **green links** are encrypted, **red links** are in the clear.



Dave

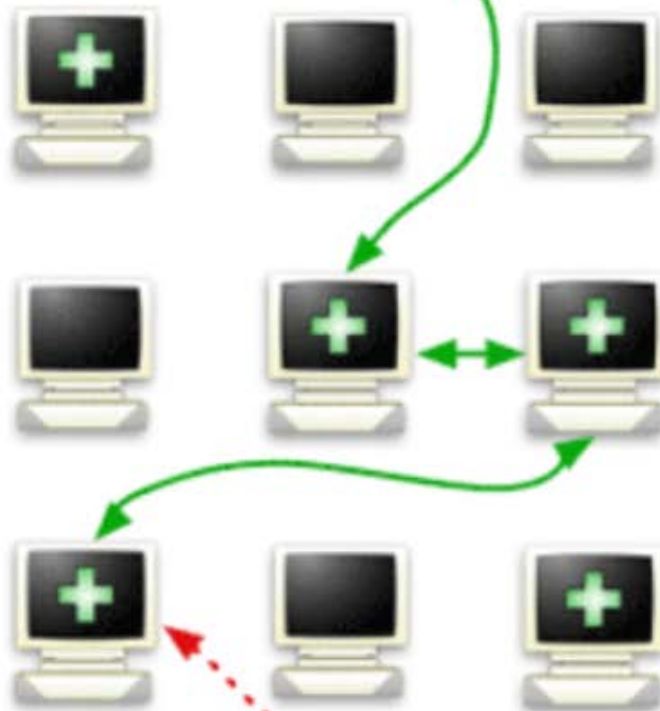

Jane



Bob

Image courtesy torproject.org

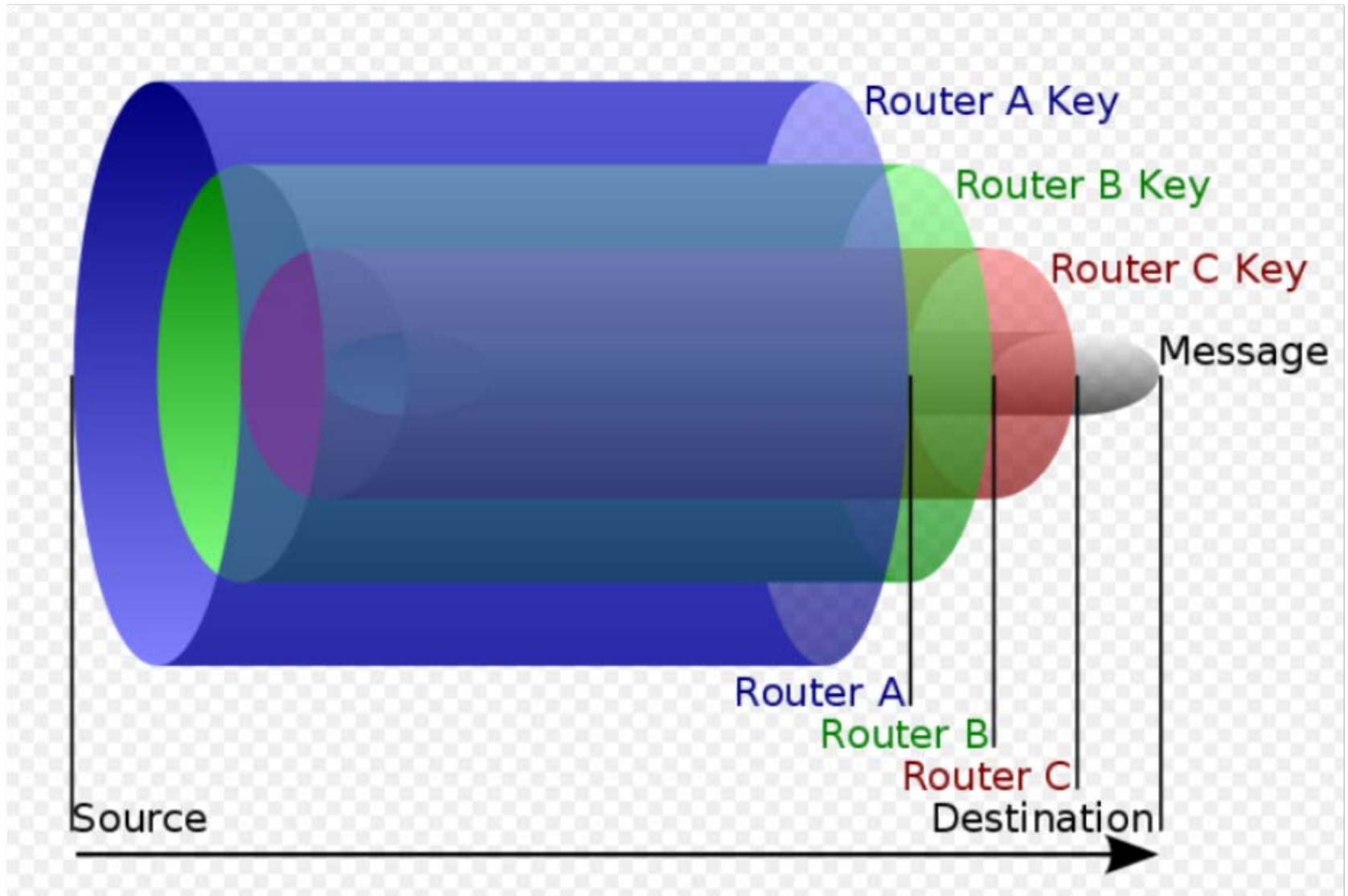

Diagram courtesy Wikimedia Commons

End of lecture