

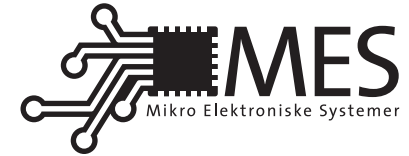

UNIVERSITY
OF OSLO



Neuromorphic Electronics

Analog Storage



- volatile short term storage
 - capacitive storage/dynamic storage
- volatile long term storage
 - digital storage and DAC
 - capacitive storage with refresh
 - multi level flipflops
- non-volatile storage
 - floating gates, analog flash ROM



Capacitive Storage

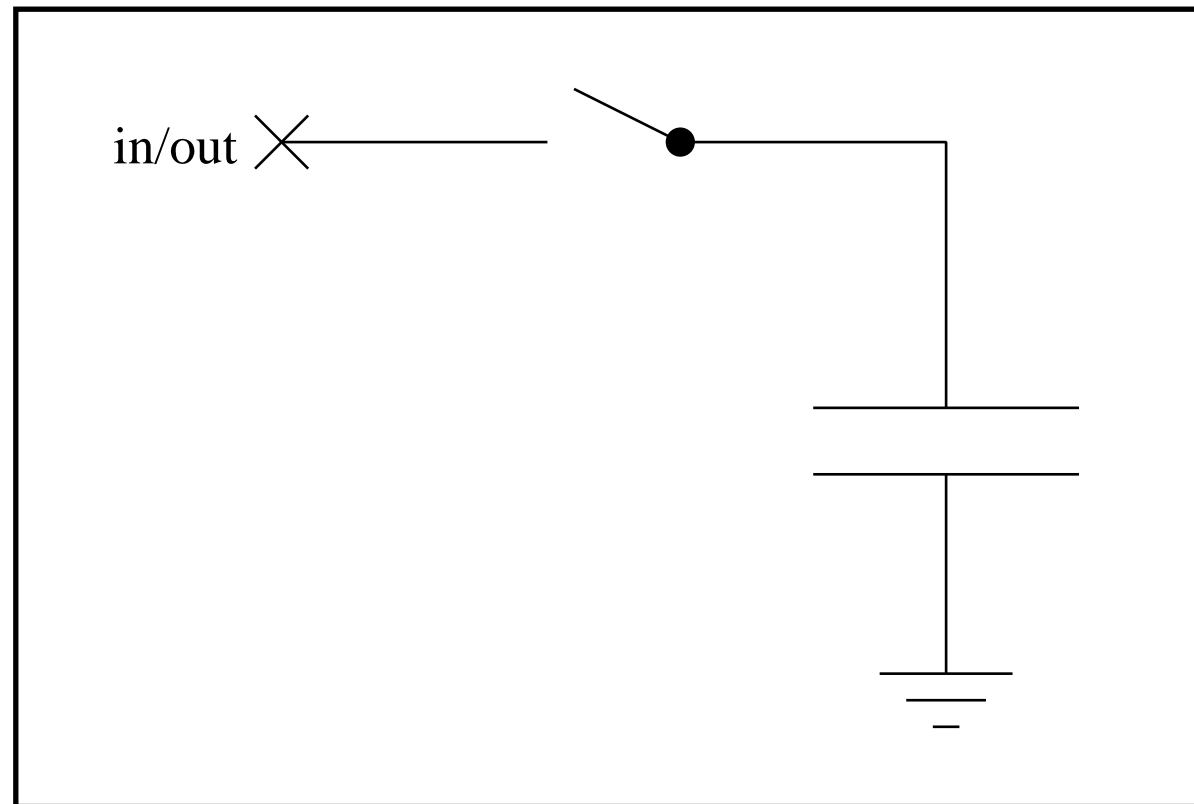



AD/DA Multi-Level Storage

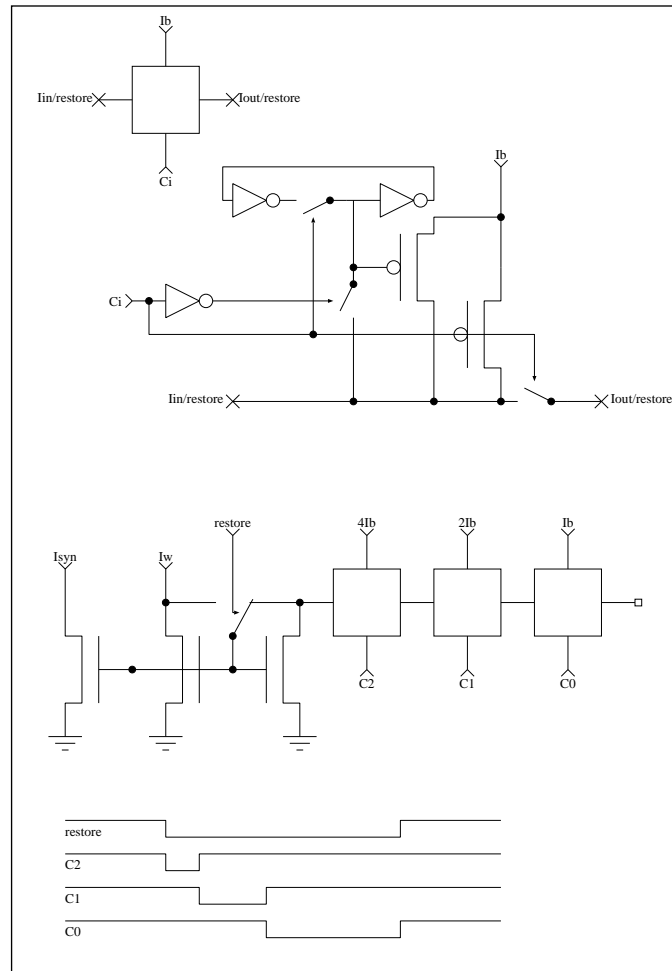



Real Multi-Level Storage (1/2)

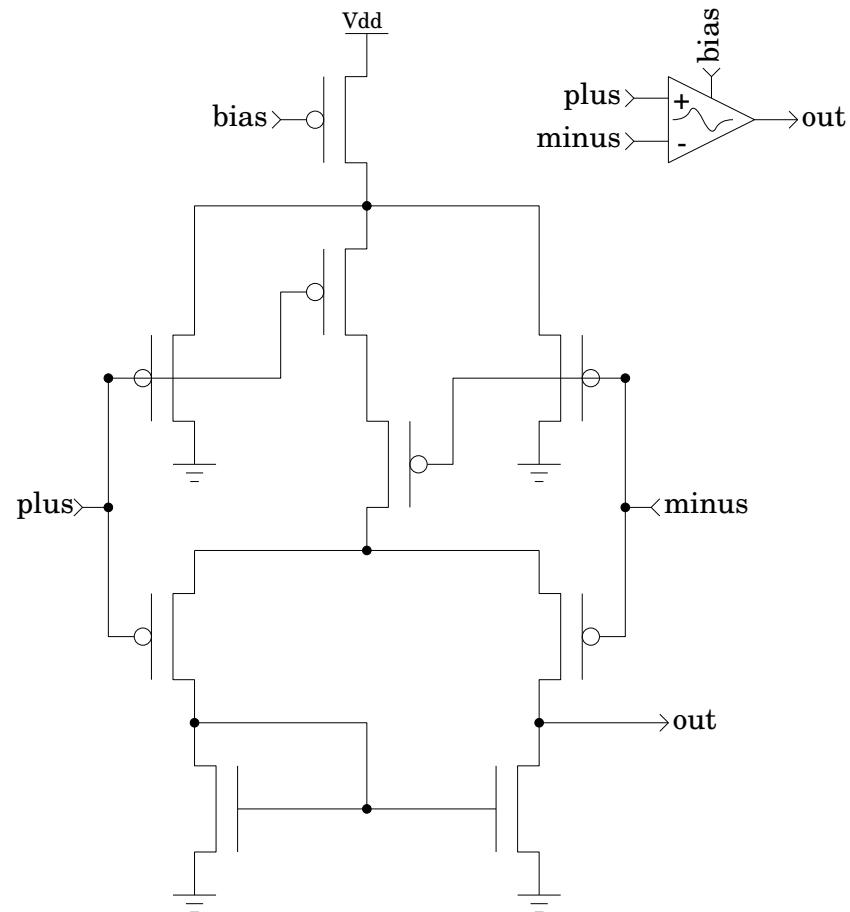

Real Multi-Level Storage (2/2)

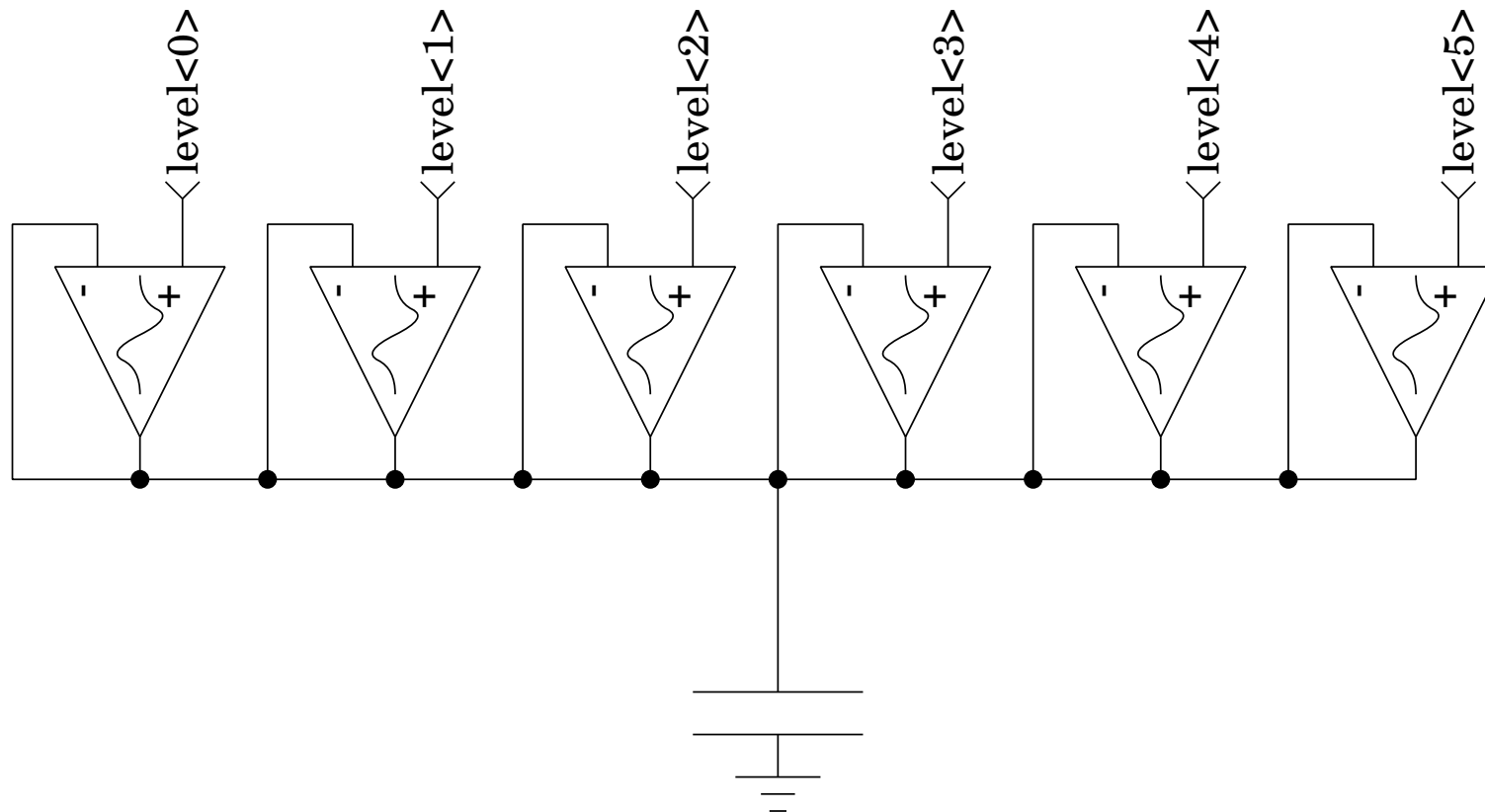



Non-Volatile Analog Storage on Floating Gates

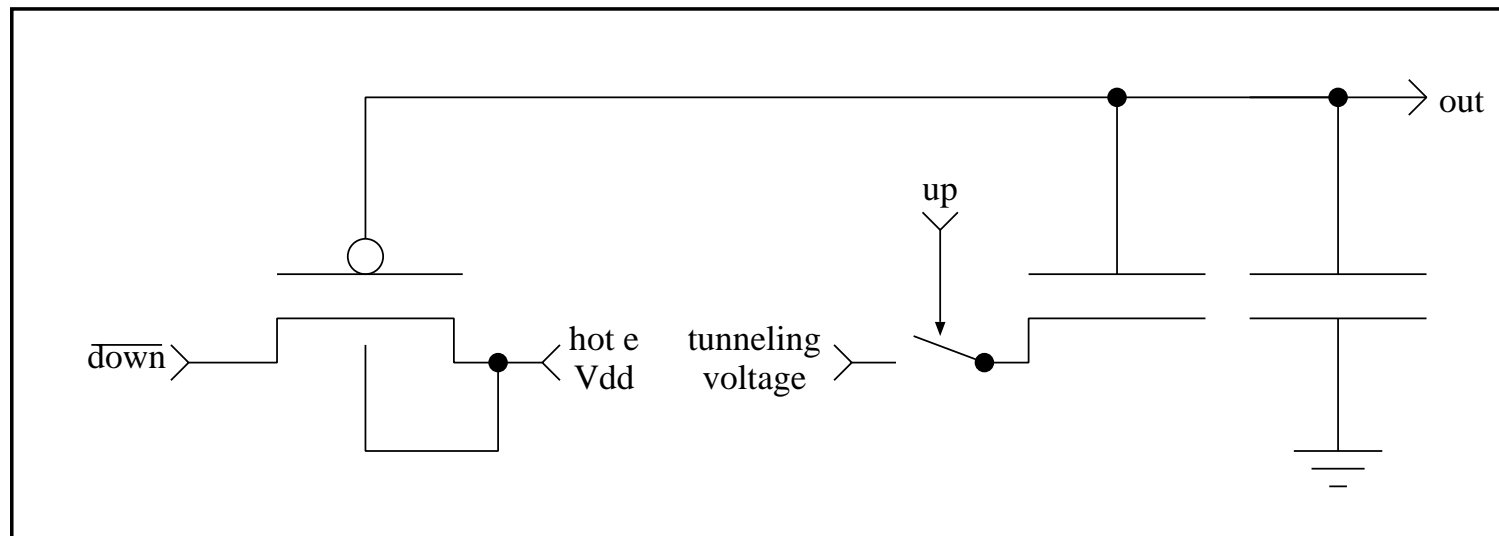



Tunneling Band Diagram

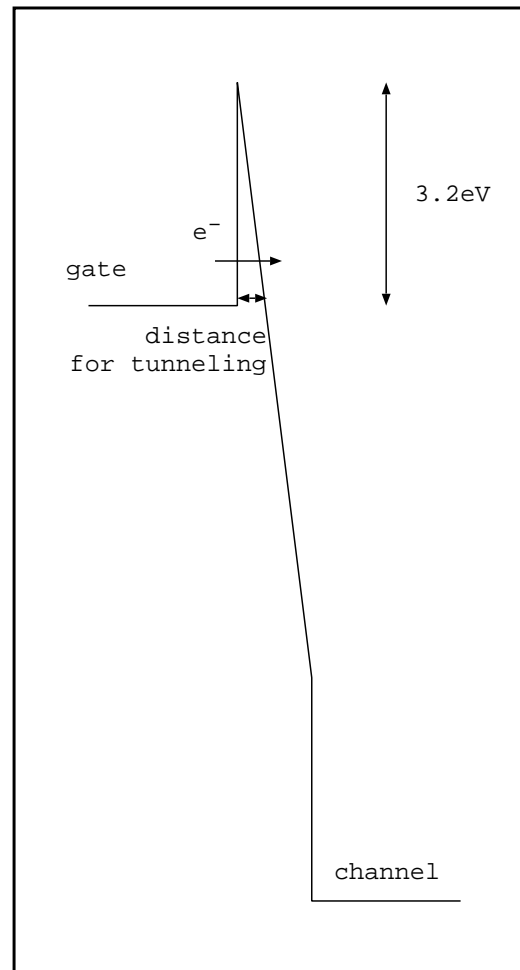



High Voltage NFET

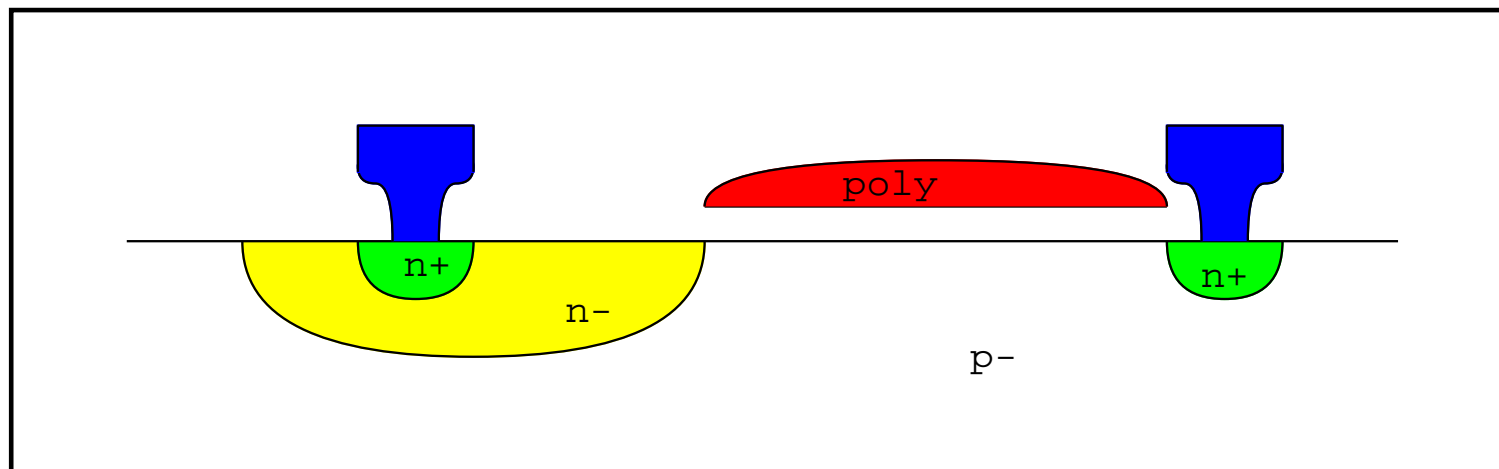

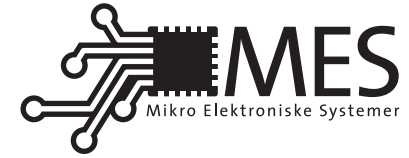

High Voltage Switch

