

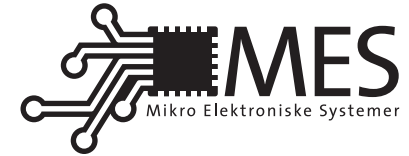

UNIVERSITY
OF OSLO



Neuromorphic Electronics

Neuromorphic Learning Circuits



The Diorio Weight Normalizer

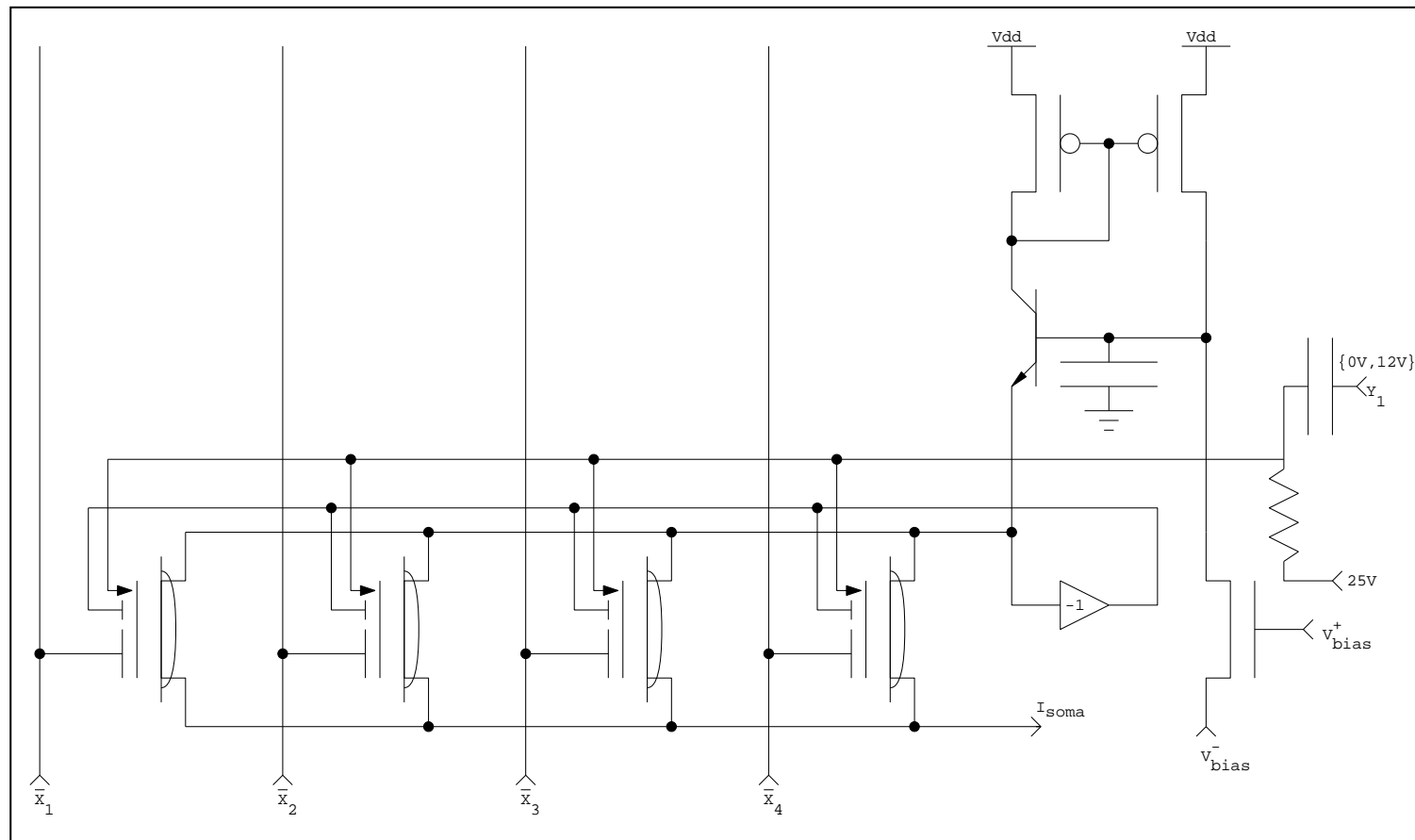

A Bistable Hebbian Synapse

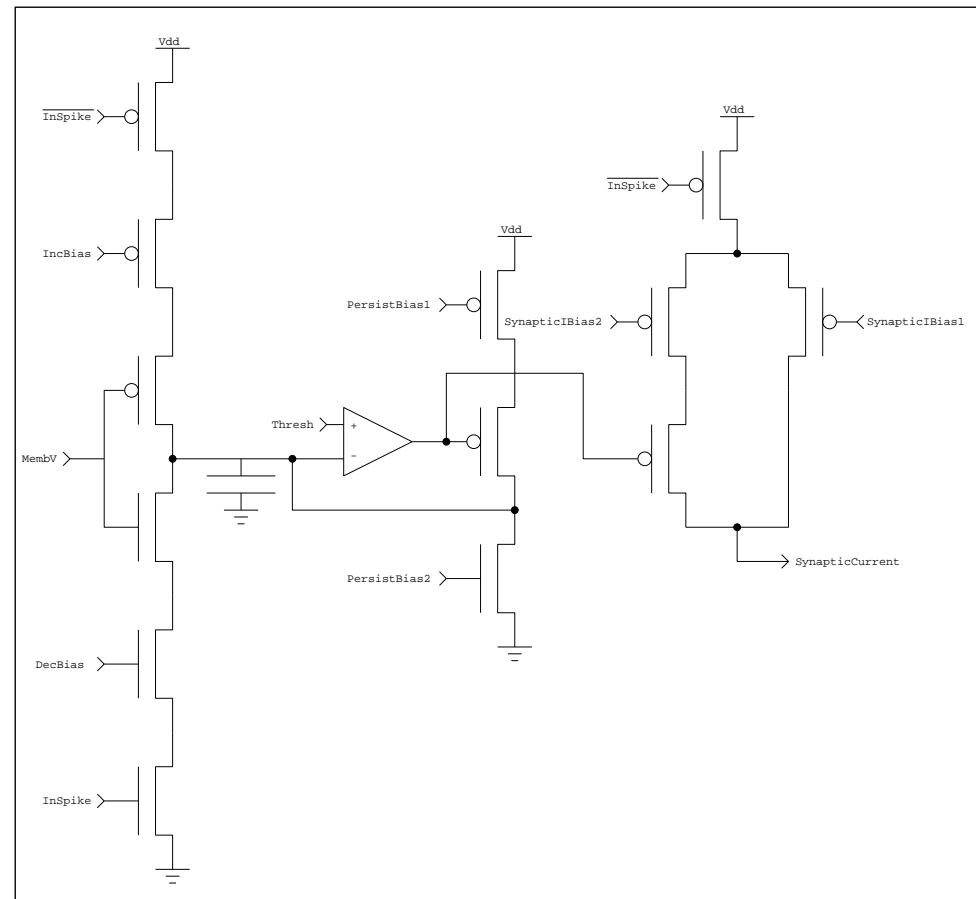



A Spike Based Learning Circuit

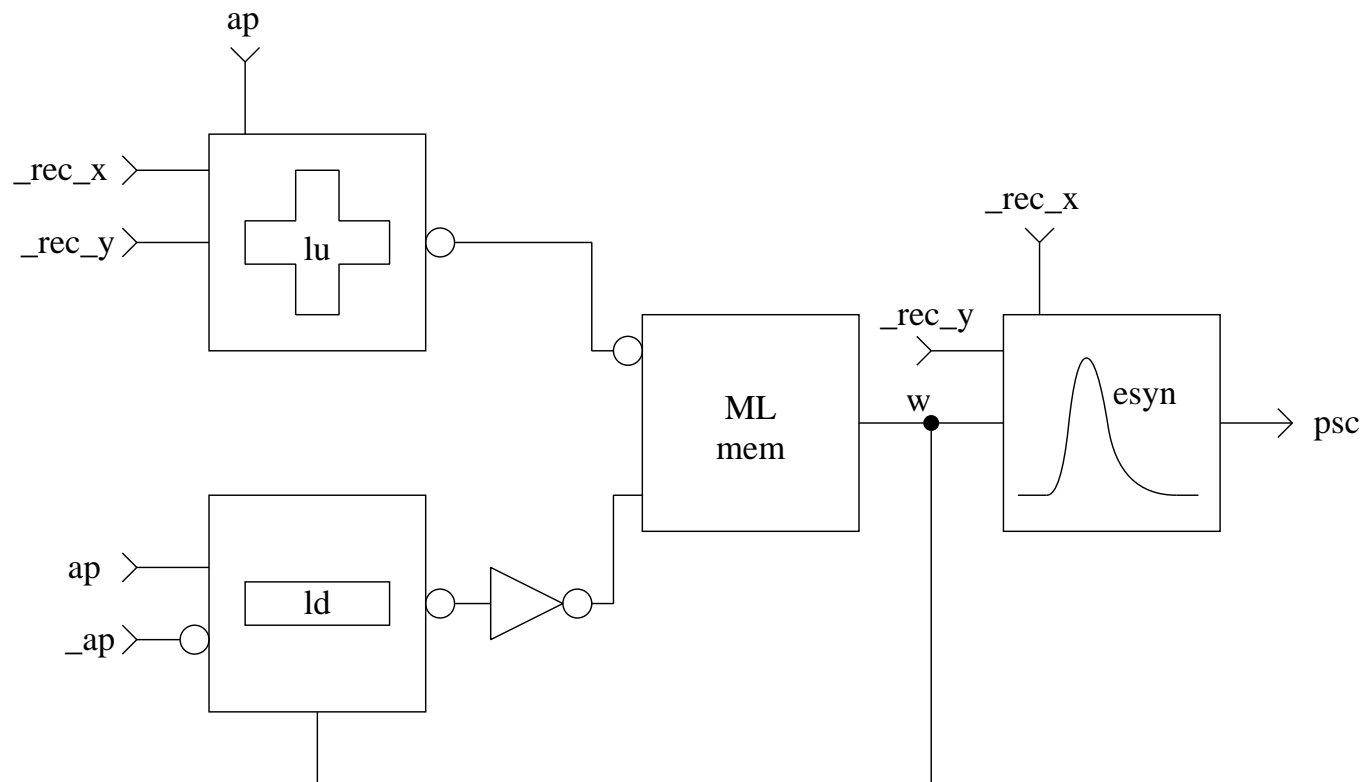



Excitatory Synapse

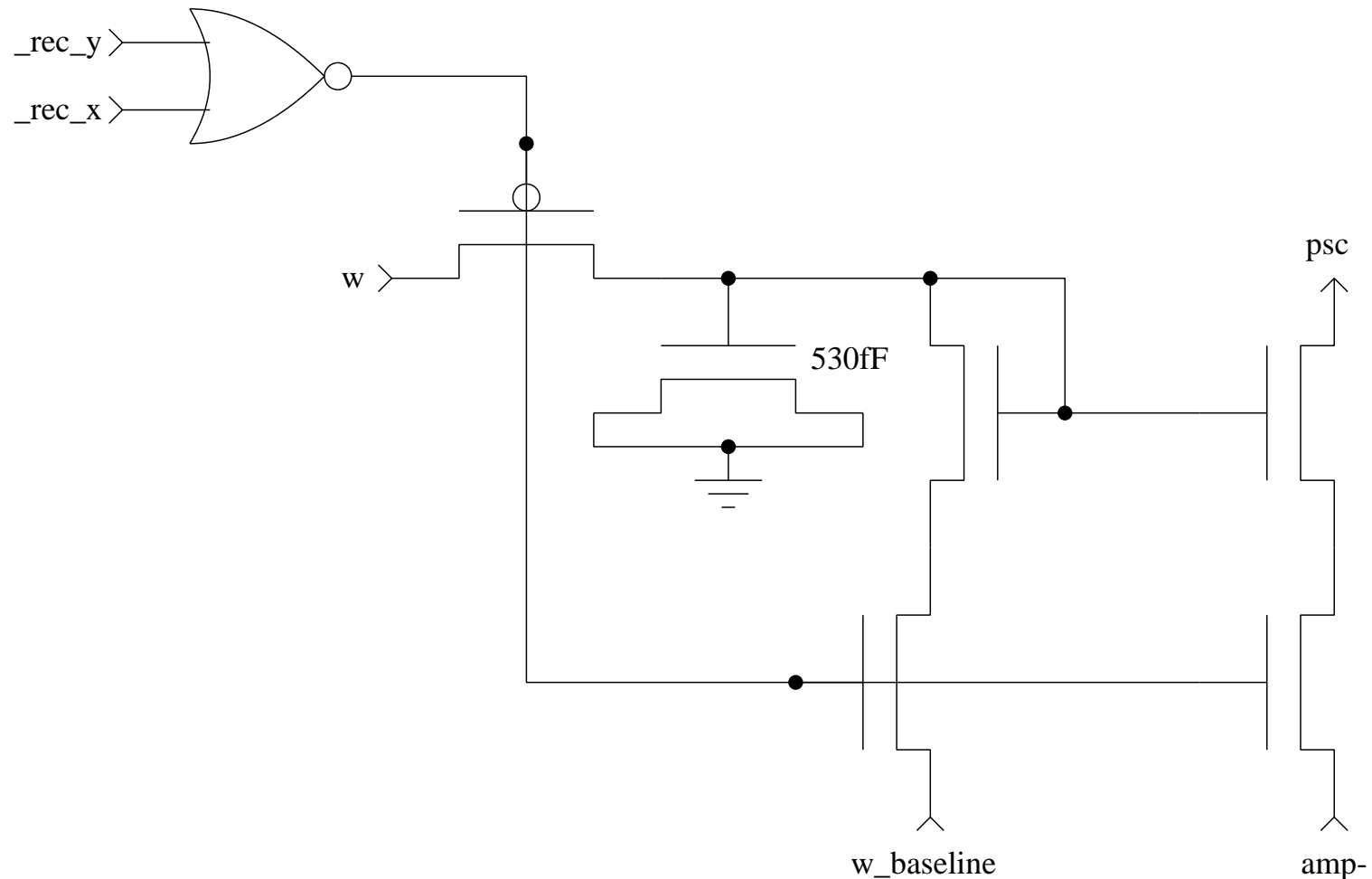



The Floating Gate Weight Storage Cell

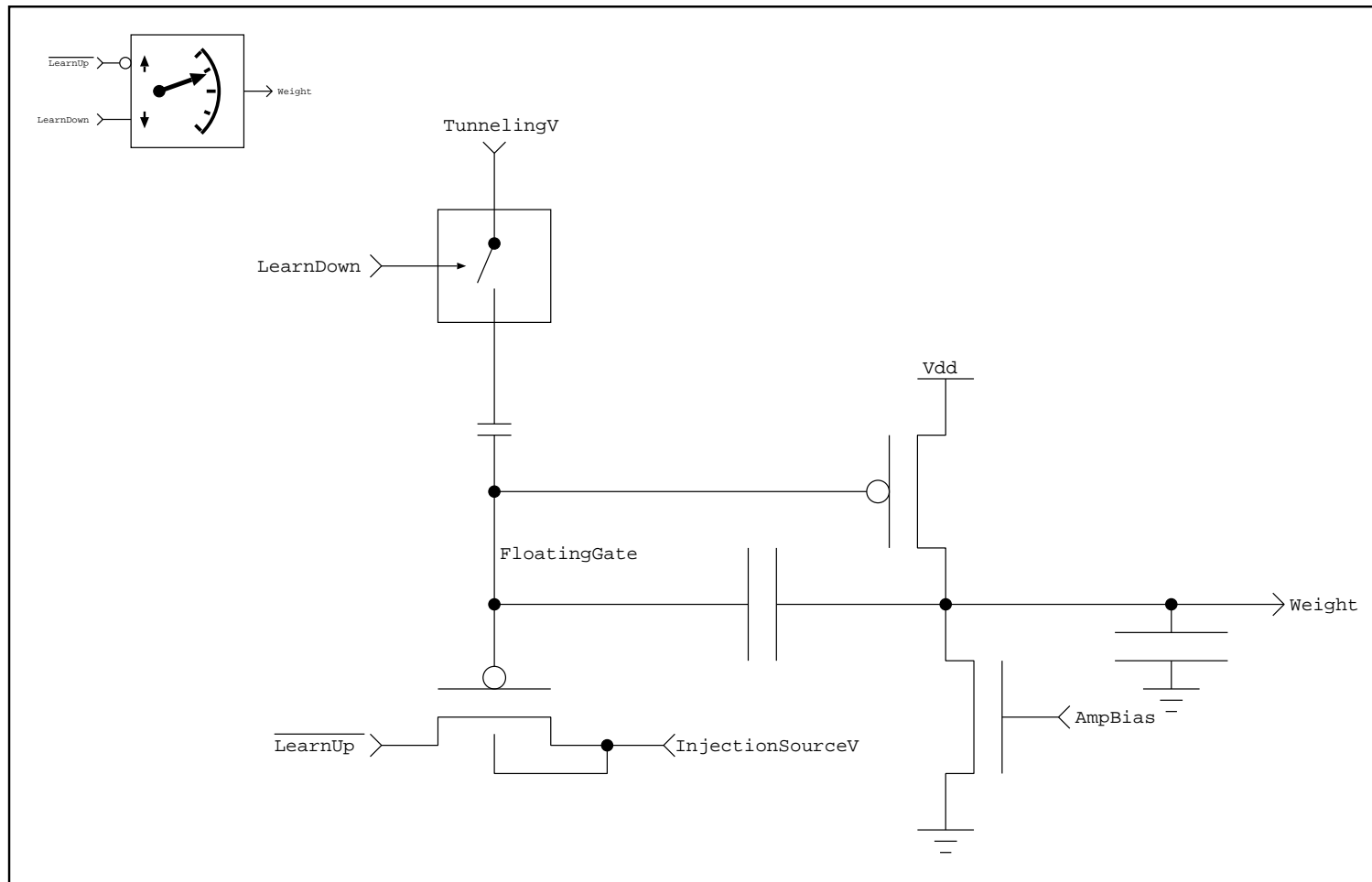



The Weak Multi-Level Weight Storage Cell

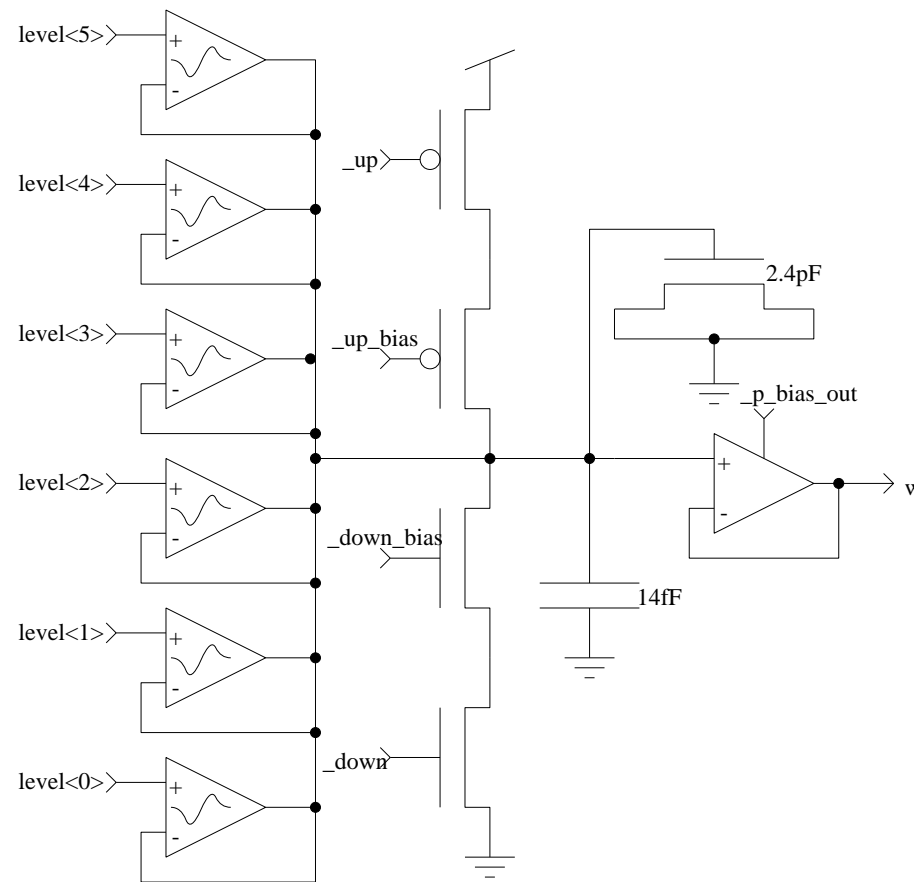

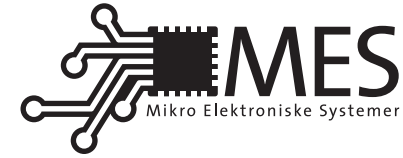

The Circuit Computing Positive Change

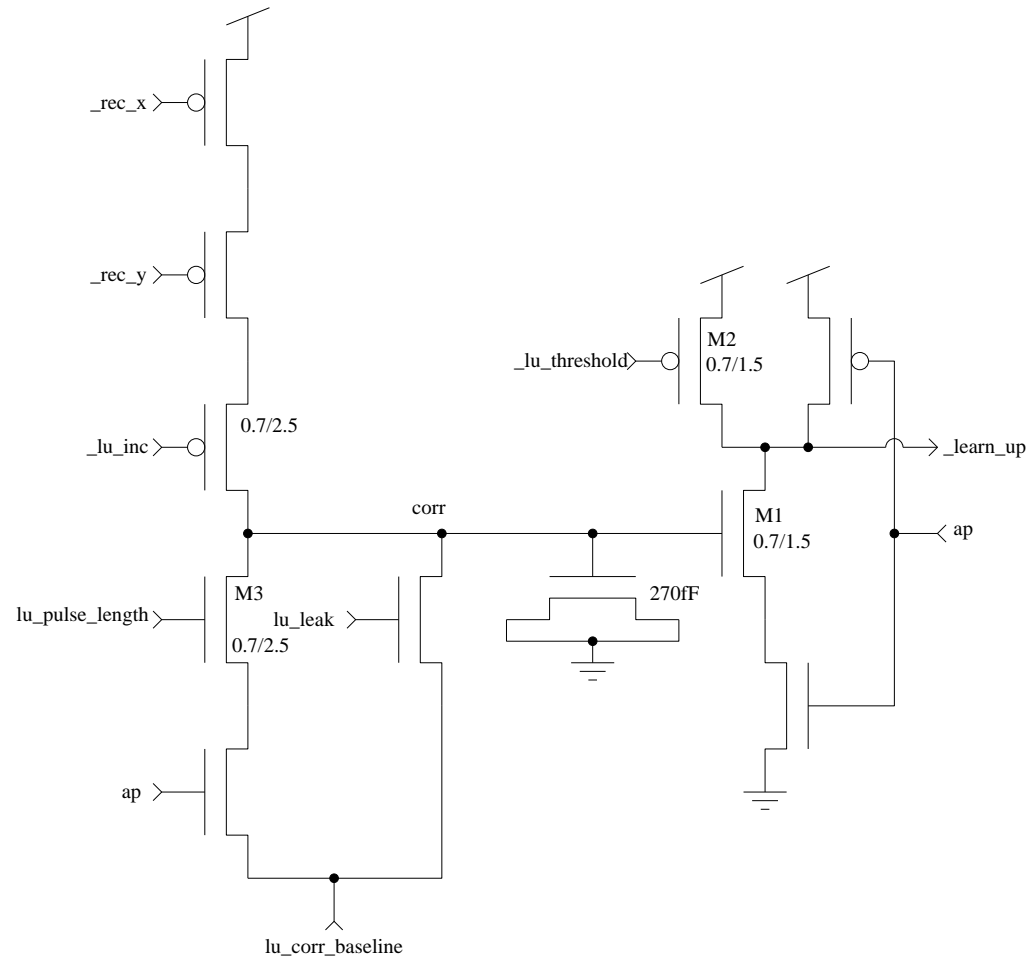



The Circuit Computing Negative Change

