

INF5490 RF MEMS

LN05: RF MEMS switches, I

Spring 2011, Oddvar Søråsen
Department of Informatics, UoO

Today's lecture

- Switches for RF and microwave
 - Examples
 - Important switch parameters
 - Performance requirements
 - Technology
 - Characteristics of RF MEMS switches
- Basic switch configurations
 - Working principles
- Design of RF MEMS switches
 - **Electromechanical design, I**
- Additional switch parameters

Next lecture, LN06

- Design of RF MEMS switches, contd.
 - **Electromechanical design, II**
 - **RF design**
- Ex. of implementations
 - Structure
 - Fabrication
 - Performance
- Special structures and actuation mechanisms
- Some challenges

Background

- **Switch - relay**
- Used for measurements, instrumentation
- Important component for RF systems
 - Signal routing
 - Re-directing of signals: antennas, transmitter/receiver
 - Connecting / selecting various system parts
 - Choice of filter in filter bank
 - Choice of network for impedance matching
 - Choice of matching circuitry for amplifier
- Telecom is a dominant user

Ex. of switch applications

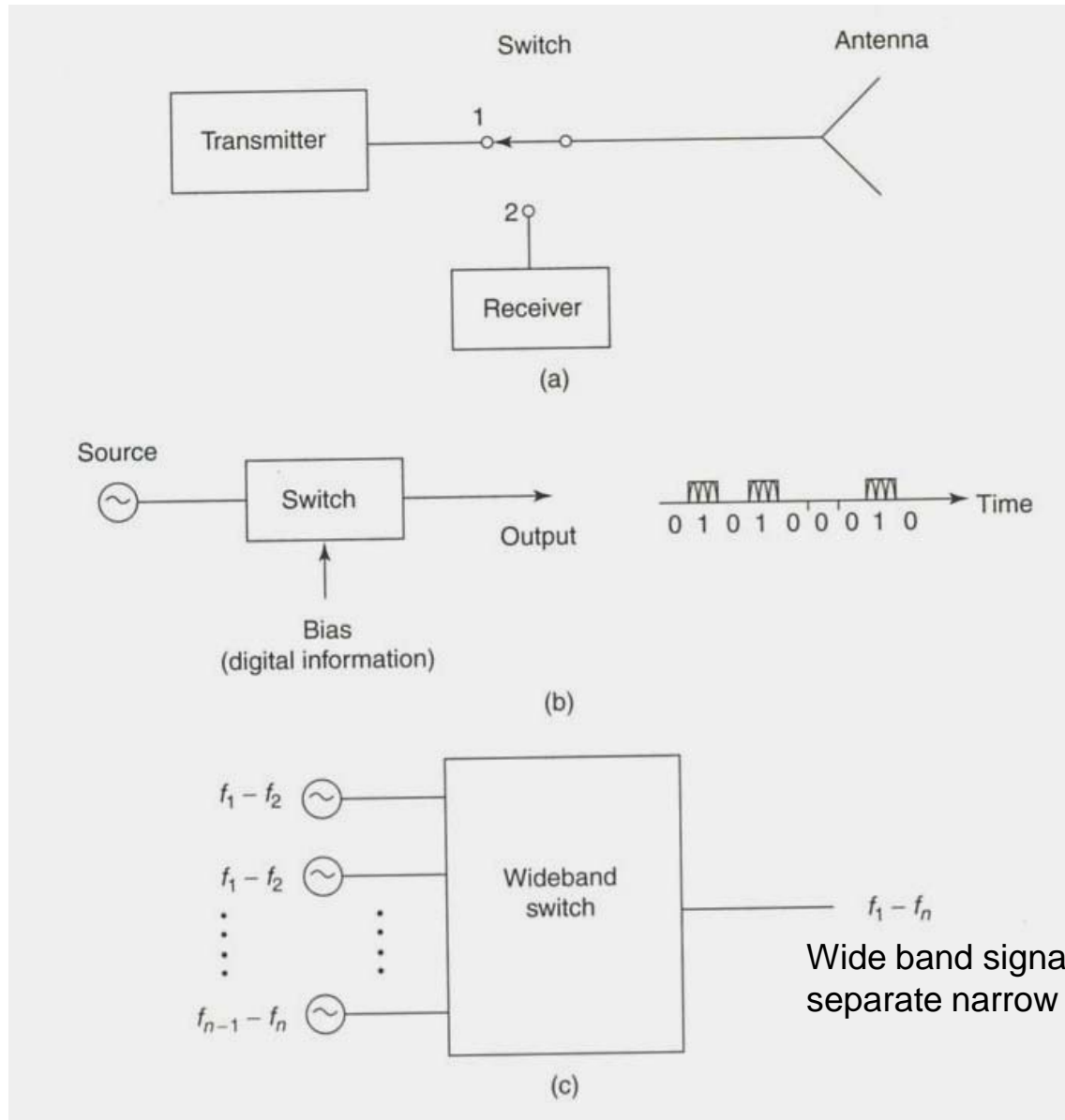

Varadan, fig. 3.1

Applications, contd.

Choose channel

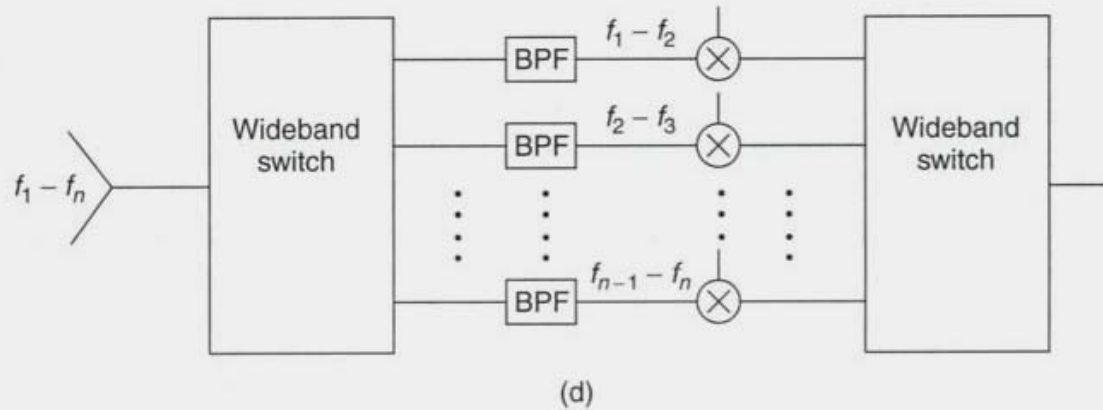

Choose measurement instrument

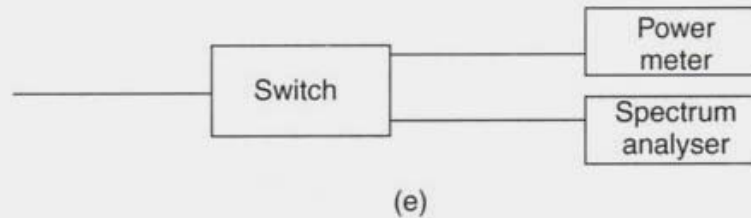

Varadan fig. 3.1

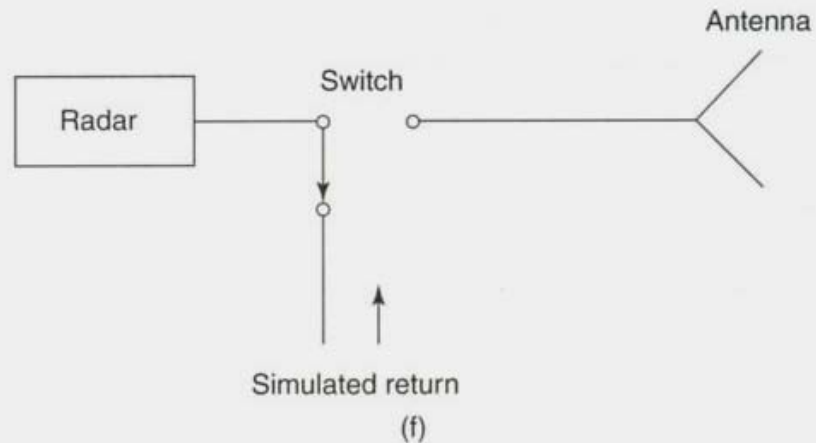

Important switch parameters (Var p.111)

- **Switch speed**
 - 50% control voltage → 90% (10%) of RF-output port envelope
- **Transition time**
 - Output RF signal 10 → 90% or 90 → 10%
- **Actuation voltage**
 - Important parameter for electromechanical design!
 - Desired: VLSI compatibility, - influences the speed
 - No problem for semiconductor components
- **Impedance matching**
 - Avoid reflections at both input and output port (for on or off)
- **RF power capability**
 - Specifies **linearity** between output power and input power
 - Possible degradation of switch for high power

Important switch parameters, contd.

- **IL = insertion loss**

- Defined for "on-state"
- Ratio between signal out (b_2) versus signal in (a_1)
- **IL** = inverse transmission coefficient = $1/S_{21}$ in dB
 - $S_{21} = b_2/a_1$ when $a_2 = 0$
- Design goal: minimize!
 - RF MEMS has low IL at several GHz
 - Much better than for semiconductor switches
 - "Skin-depth" effect – increased loss at high frequencies

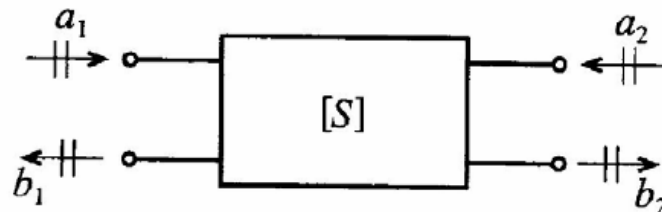

Important switch parameters, contd.

- **Isolation**

- Defined in "off-state"
- The **inverse** ratio between signal out (b_2) versus signal in (a_1)
 - Defined as $1/S_{21}$ i dB
- Alternatively: The inverse ratio between signal transmitted back to the input (b_1) versus signal in on the output port (a_2)
 - Defined as $1/S_{12}$ i dB
- Large value \rightarrow low coupling between terminals

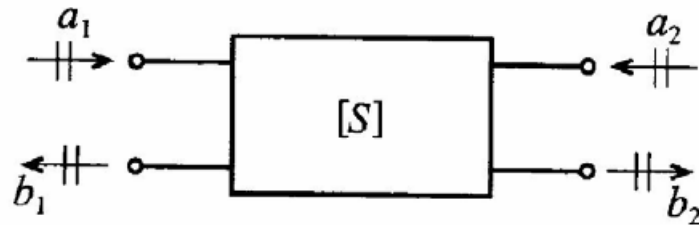

Performance requirements

- High **performance parameters** are desired
 - Low loss
 - Good isolation
 - Low cross-talk
 - Short switching time
 - Long lifetime
 - Reliability
- Choice of **switch technology** is dependent of
 - RF-signal frequency
 - Speed requirements
 - Signal level
 - RF power capability

Technology choice

- Traditional mechanical switches (**relays**)
 - ala light switch
 - Low loss (+)
 - Good isolation (+)
 - Can handle high power (+)
 - Slow (-)
 - Mechanical degradation (-)
 - Contact degradation, reduced lifetime (-)
 - Macroscopic relays: bulky, expensive (-)

Technology choice, contd.

- **Semiconductor switches** (solid-state)
 - Used extensively today in portable devices !
 - FET (Field Effect Transistors), CMOS, PIN-diodes
 - High reliability (+)
 - Integration with Si (+)
 - FET degrades at high frequency (-)
 - Large insertion loss, high resistive loss (-)
 - Limited isolation (-)
 - Poor linearity (-)
 - High power consumption (-)
 - Limited “high power” capability (-)

PIN-diode

- High reliability technology
- Varadan fig. 3.6
 - PIN: p – insulator - n
 - **Forward** biased: low R
 - **Reverse** biased: low C due to isolator layer → high impedance Z

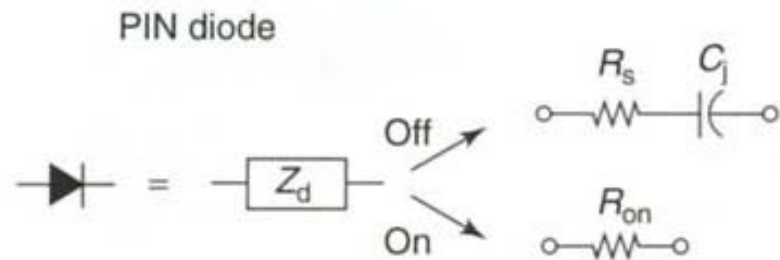
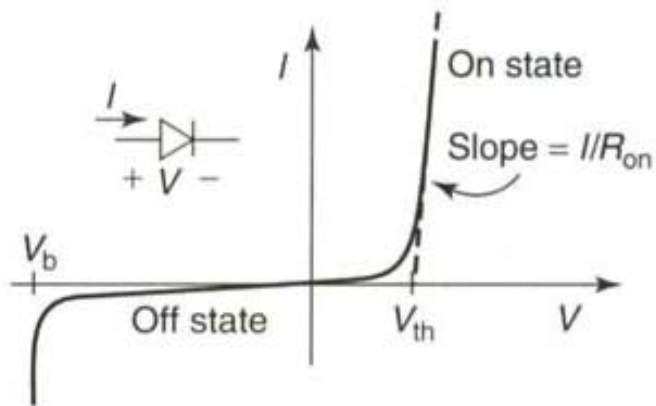

PIN-diode used in system

- The biasing of the PIN-diode determines the switching
 - Forward bias: low R
 - Reverse bias: high Z
- Typical terms
 - Single-pole single-throw, **SPST**
 - Single-pole double-throw, **SPDT**
 - Varadan fig. 3.8

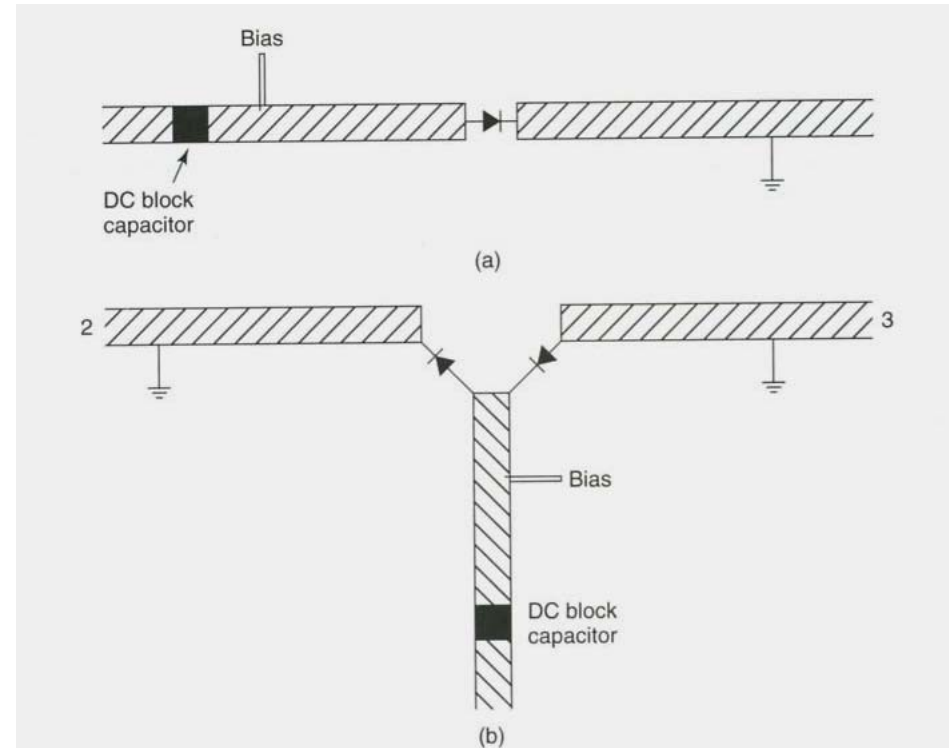

RF MEMS switches

- **A great need exists for having switches with better performance!**
 - → MEMS switches:
 - The first ex. of RF MEMS-components (78→)
 - Many implementations exist
 - *F.ex. in Gabriel M. Rebeiz: "RF MEMS – Theory, Design and Technology" (Wiley 2003)*
 - Publications
 - Most mature RF MEMS field
 - Slow adoption

Benefits and typical characteristics of RF MEMS switches

FSRM



RF MEMS switch: key advantages and issues

- + • **Ultra low power** consumption: 10-100nW
- + • **Ultra-high isolation** → airgap: low state C ~fF, 0.1-40GHz
- + • **Low insertion loss** → ~ -0.1dB, 0.1-40GHz
- + • **Practically no intermodulation**: very linear
- + • **Low cost** ~ simple technology, integrable with RF ICs
(problem → cost & performance of the full packaged structure)
- + • **High linearity**
 - • **Speed limited** by mechanical nature: 1-100μs
 - • **Power handling limited**: <100mW
 - • **Reliability**: limited (today) ~10⁹-10¹⁰ cycles
no reliable switch to handle ~few Watts
 - • **Packaging**: needs inert ambient & low humidity & **low cost**

49

Comparing performance

TABLE 1.2. Performance Comparison of FETs, PIN Diode, and RF MEMS Electrostatic Switches

Parameter	RF MEMS	PIN	FET
Voltage (V)	20–80	± 3 –5	3–5
Current (mA)	0	3–20	0
Power consumption ^a (mW)	0.05–0.1	5–100	0.05–0.1
Switching time	1–300 μ s	1–100 ns	1–100 ns
C_{up} (series) (fF)	1–6	40–80	70–140
R_s (series) (Ω)	0.5–2	2–4	4–6
Capacitance ratio ^b	40–500 ^b	10	n/a
Cutoff frequency (THz)	20–80	1–4	0.5–2
Isolation (1–10 GHz)	Very high	High	Medium
Isolation (10–40 GHz)	Very high	Medium	Low
Isolation (60–100 GHz)	High	Medium	None
Loss (1–100 GHz) (dB)	0.05–0.2	0.3–1.2	0.4–2.5
Power handling (W)	<1	<10	<10
Third-order intercept point (dBm)	+66–80	+27–45	+27–45

^aIncludes voltage upconverter or drive circuitry.

^bCapacitive switch only. A ratio of 500 is achieved with high- ϵ_r dielectrics.

Two basic switch configurations

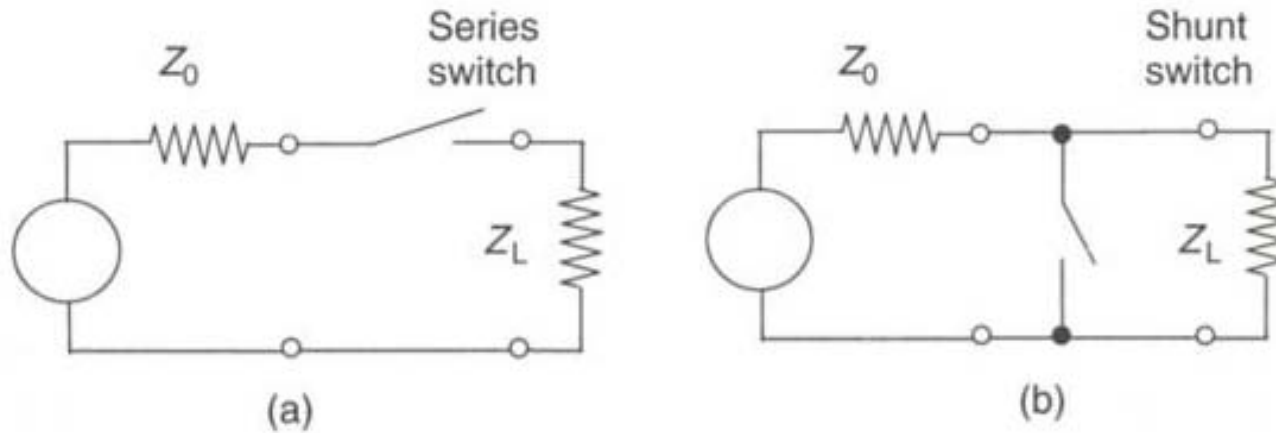

Basic switch structures

- **Series switch**

- Contact switch, ohmic switch (relay) *
- Cantilever beam
- Capacitive switch (“contact less”)
 - RF-signals short-circuited via C ($Z=1/j\omega C$)
 - Impedance depends on value of C

- **Shunt switch**

- Shunt capacitive switch *
- clamped-clamped beam (c-c beam)
- Shunt contact switch

* most used

RF MEM switches: capacitive & contact

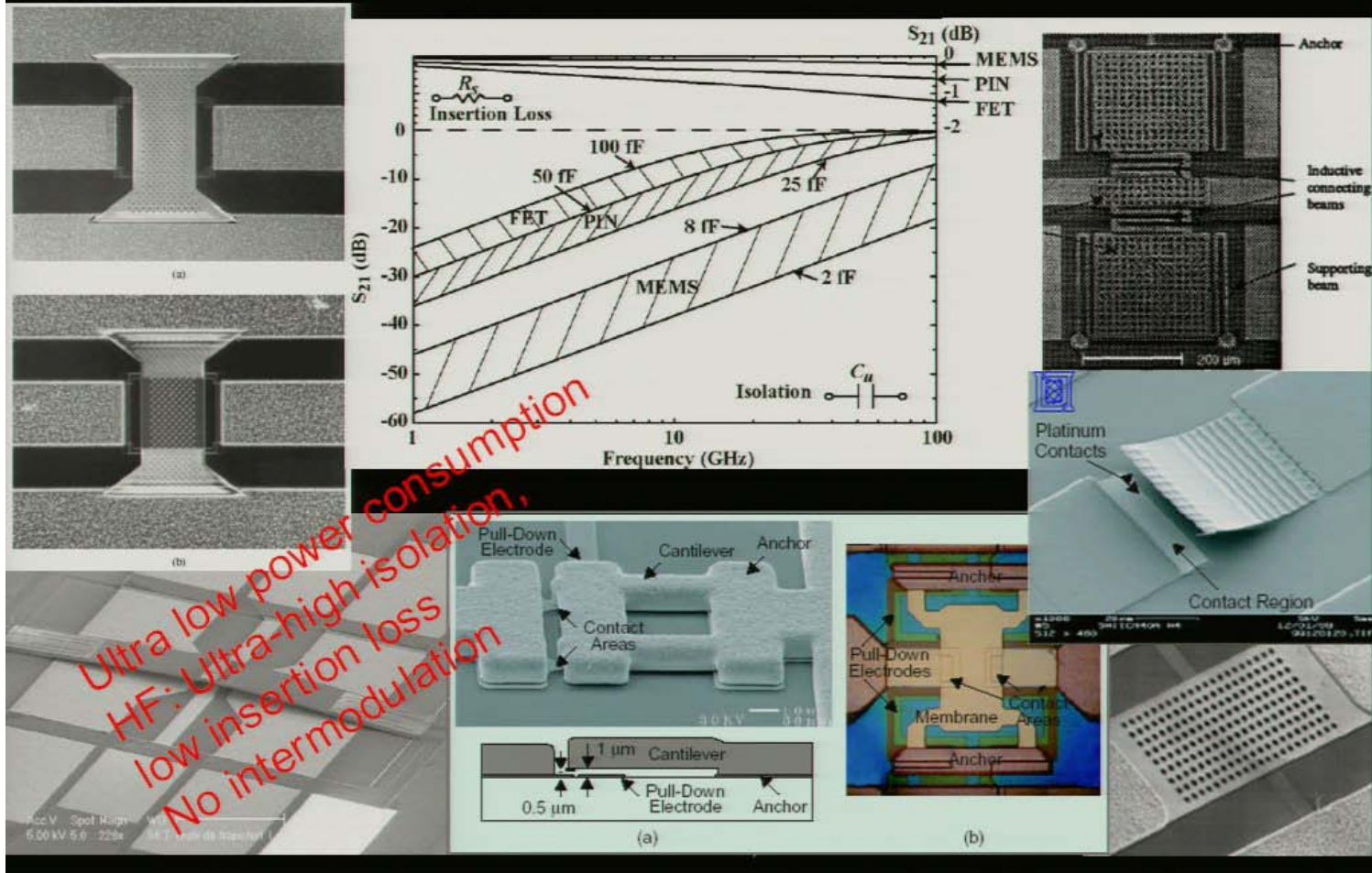

Adrian Ionescu, EPFL. Europractice – STIMESI, Nov 2007

Series contact switch

- **Cantilever** beam switch

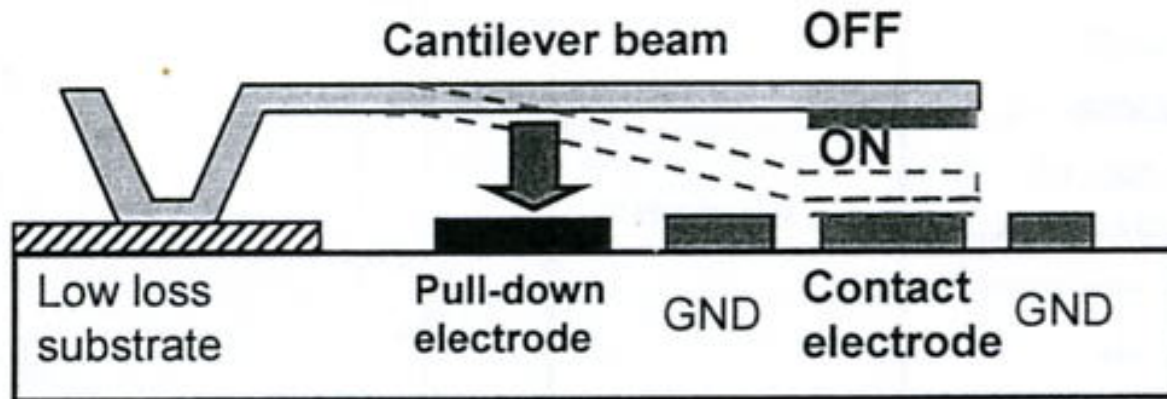

coplanar waveguide

Signal propagation **into** the paper plane

Signal propagates perpendicular to cantilever

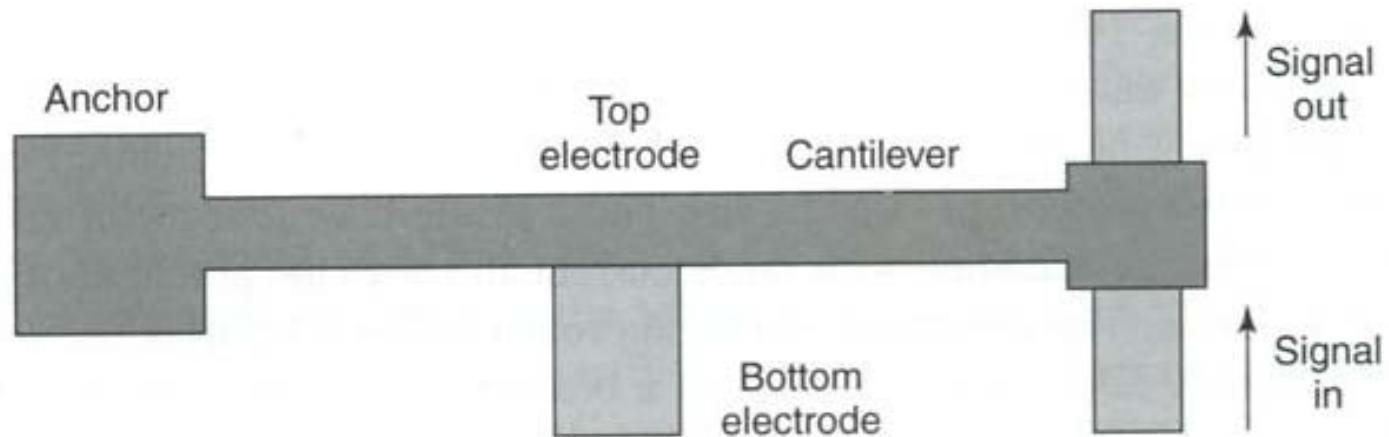

Separate pull-down electrode

Actuation voltage between beam and bottom electrode

Separate "contact metal" at beam end

Working principle

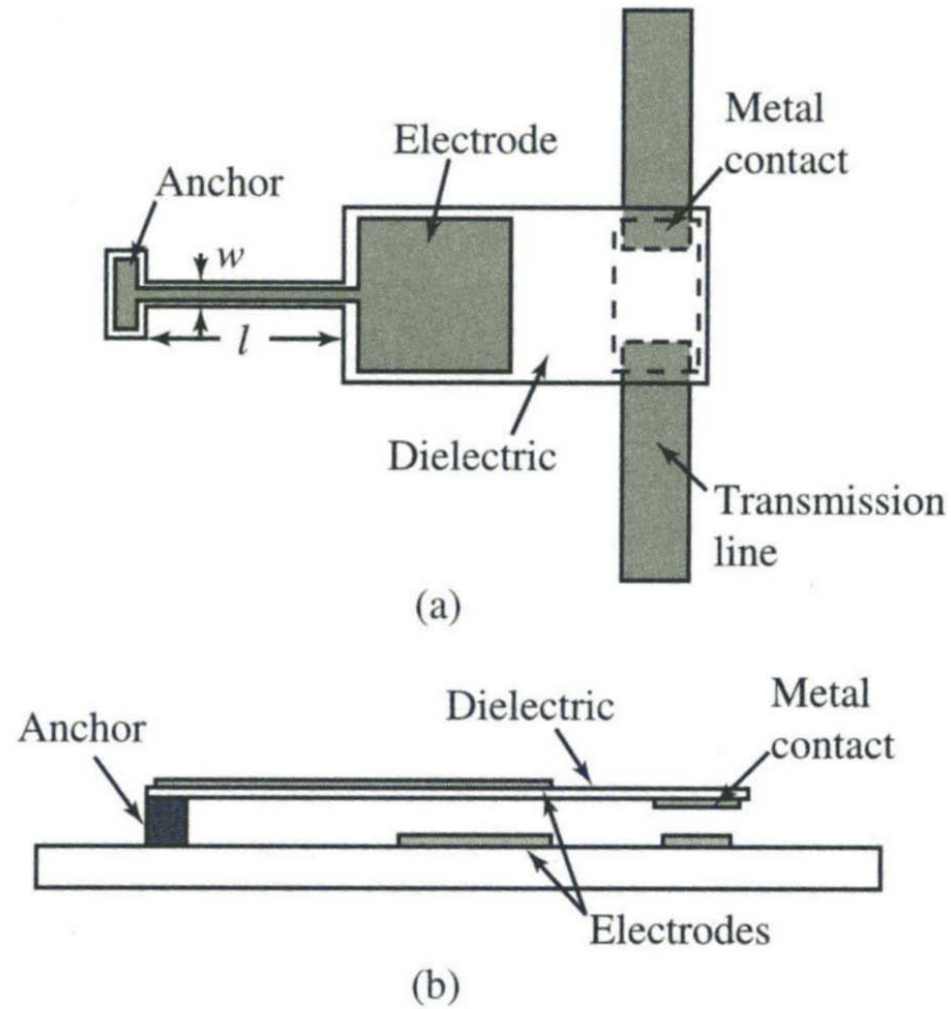

More realistic structure

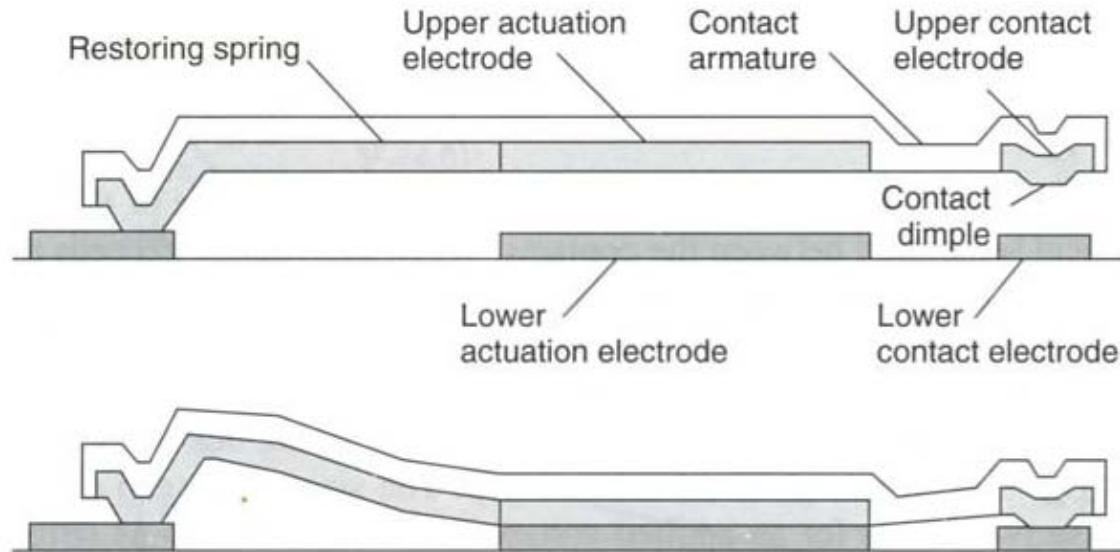

(a)

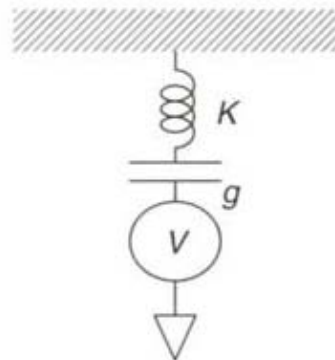

(b)

Varadan fig 3.16

Signal propagation along beam

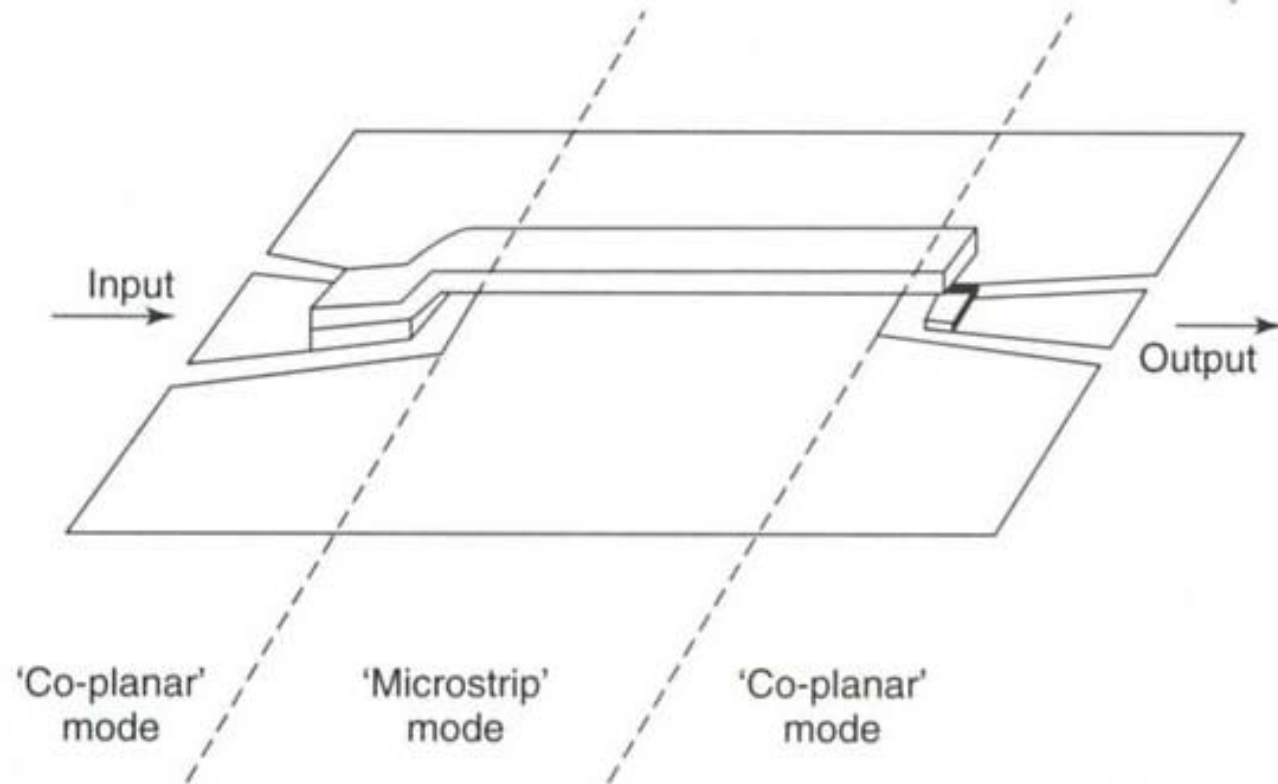

Doubly supported cantilever beam

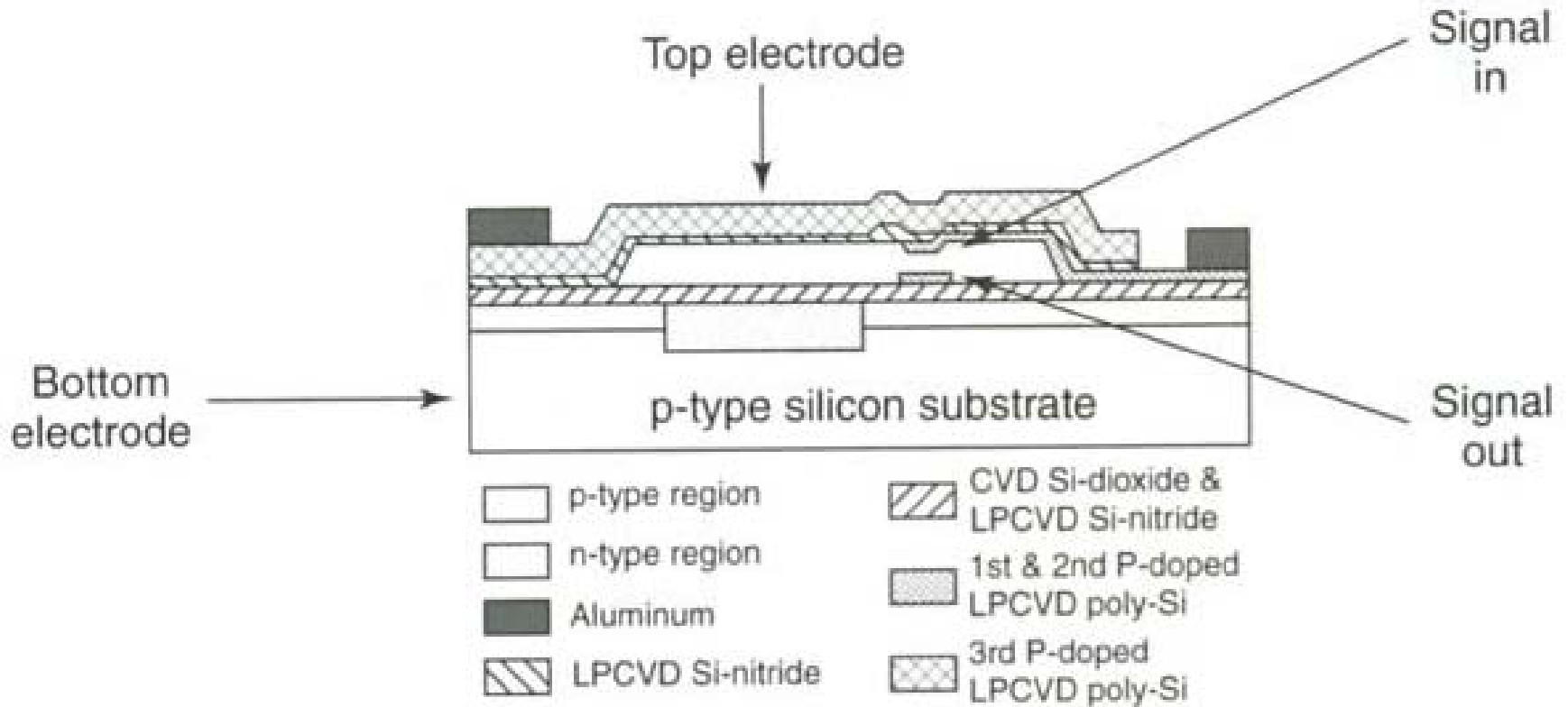

Series switch

- **Ideal** requirements – typical parameters
 - "Open/short" transmission line (t-line)
 - typical: 0.1 to 40 GHz
 - "Infinite" isolation (up)
 - typical: -50 dB to -60 dB at 1 GHz
 - "Zero" insertion loss (down)
 - typical: -0.1 dB to -0.2 dB

Cantilever beam switch: critical parameters

- **Contact resistance** for metal – metal
 - Contact pressure (not too low, not too high)
 - Surface roughness influences
 - Degradation due to increased resistance after some time
 - Soft vs hard metals (gold vs alloys)
- **Actuation voltage** vs spring constant (not too low, not too high)
- Possibility of **”stiction”** (”stuck-at”)
 - Restoring spring force vs adhesion forces
- **Reliability**
 - Aging
 - Max. number of contact cycles
 - High current is critical (”hot switching”)
 - melting, conductive metal damp → ”microwelding”
- **Self actuation**
 - $V_{RF} \text{ (RMS)} > V_{\text{actuation}}$

Typical shunt switch

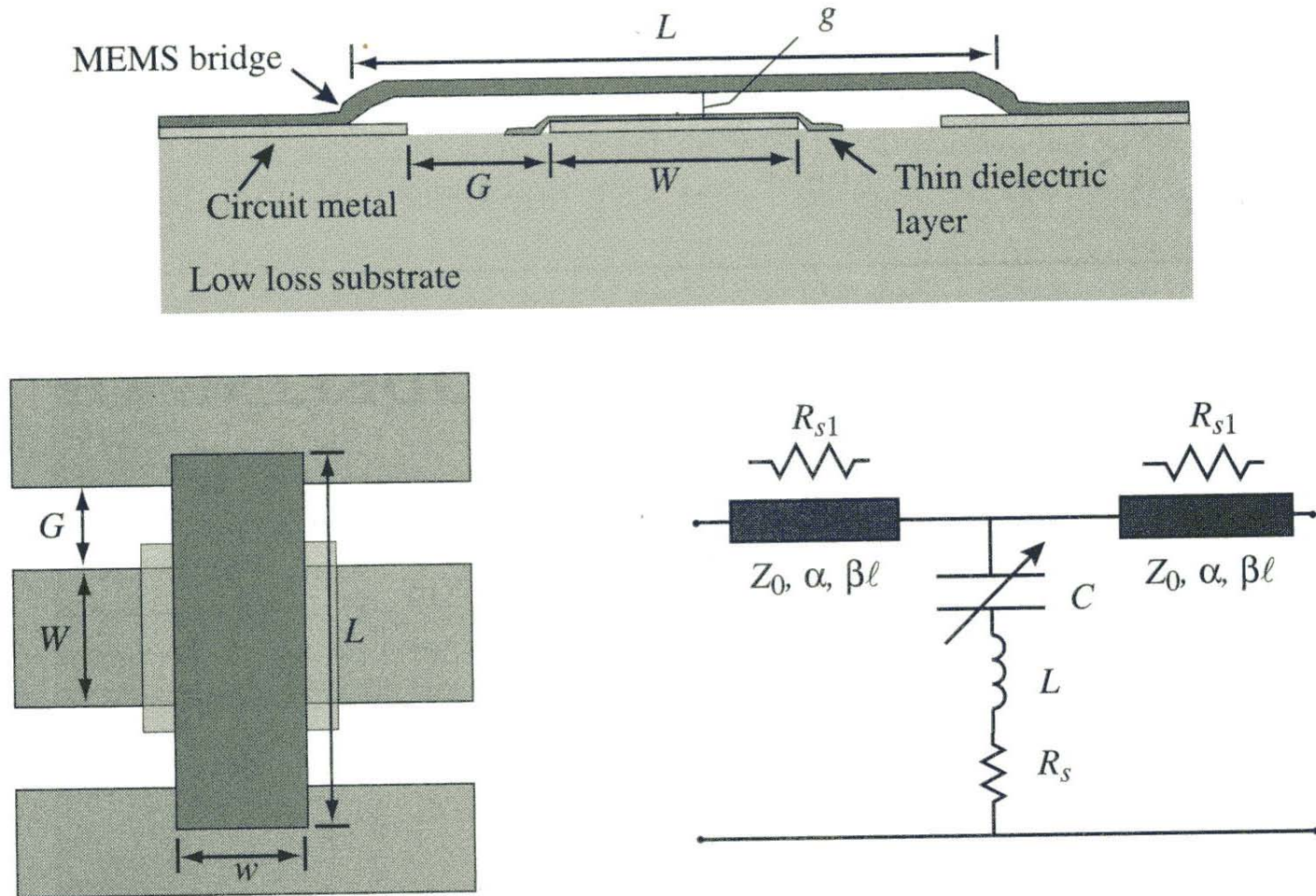
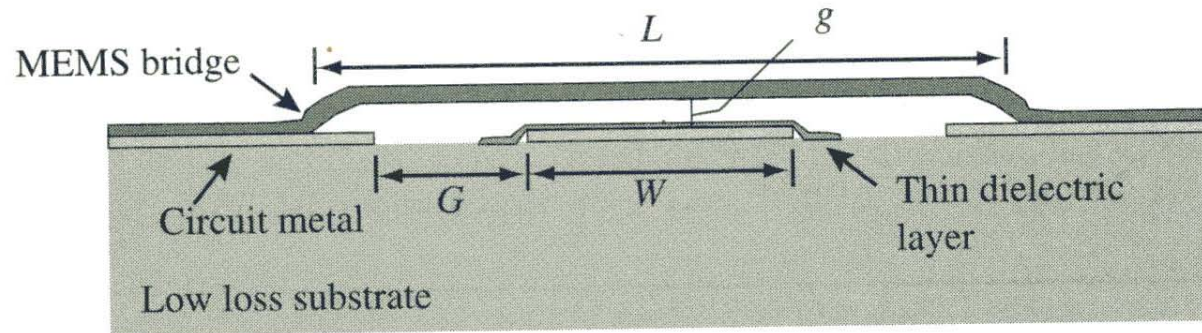

Figure 4.1. Illustration of a typical MEMS shunt switch shown in cross section and plan view. The equivalent circuit is also shown [6] (Copyright IEEE).

Typical shunt switch



Bridge up

- C to ground = small
- Signal passes through

Bridge down

- C to ground = large
- Signal is shorted to ground
- Signal does not pass

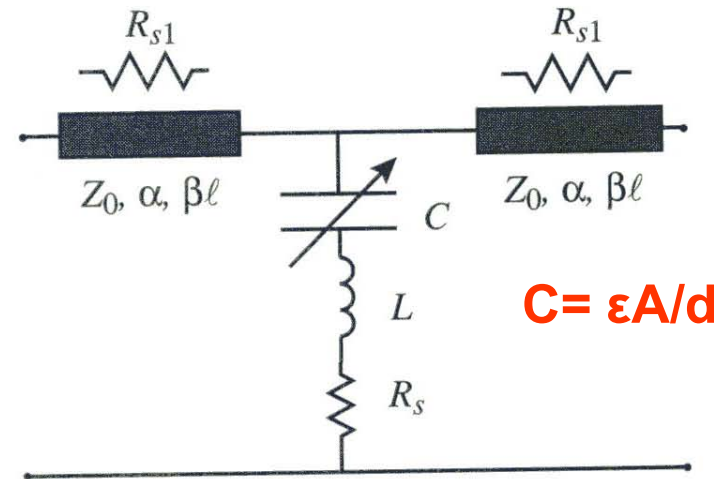
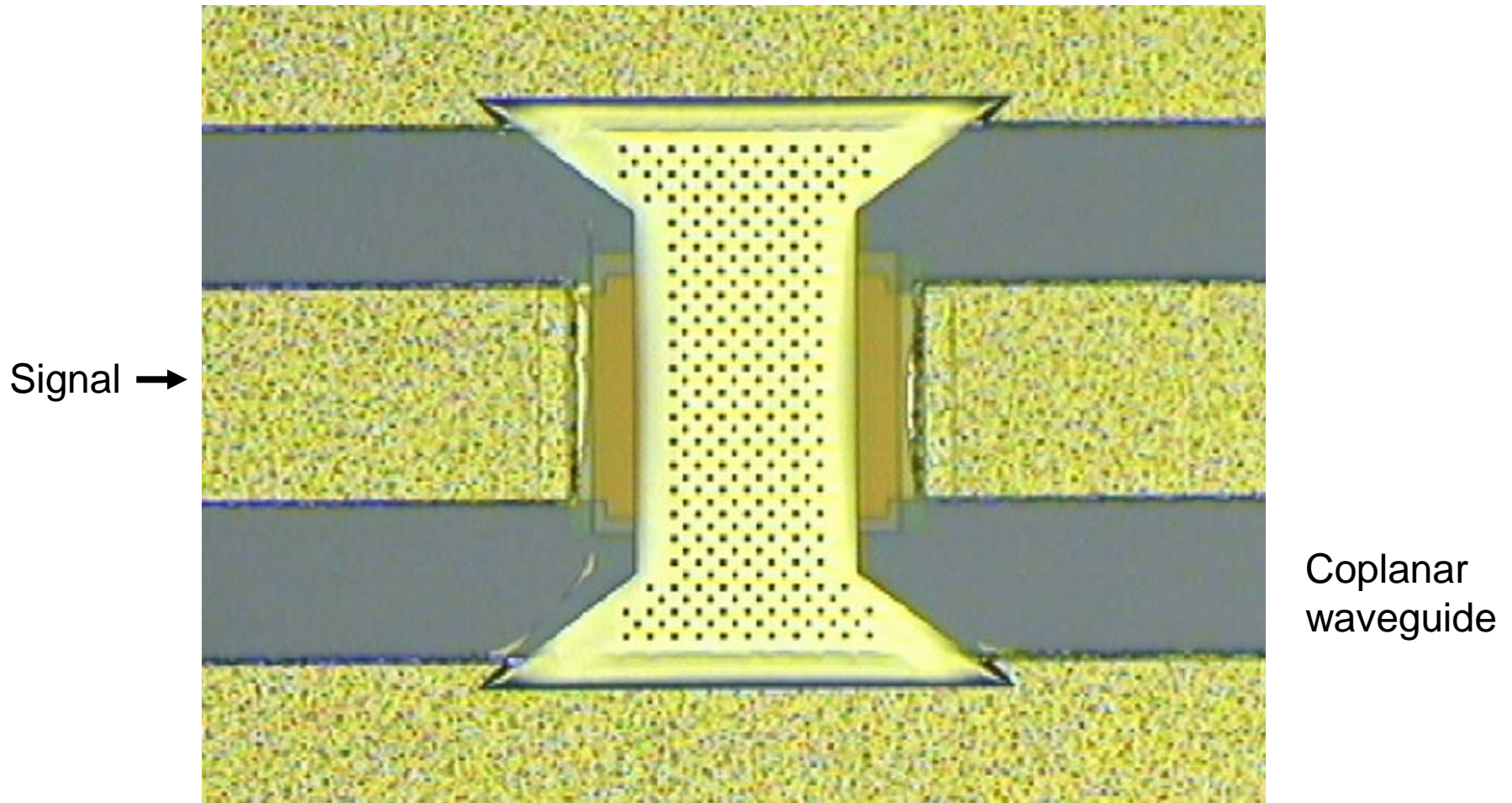

Figure 4.1. Illustration of a typical MEMS shunt switch shown in cross section and plan view. The equivalent circuit is also shown [6] (Copyright IEEE).

Shunt capacitive switch, contd.

- $C_{\text{down}} / C_{\text{up}}$ should be > 100
 - $C = \epsilon A/d$
 - $C_{\text{down}} = C_{\text{large}}$
 - $C_{\text{up}} = C_{\text{small}}$
- Impedance $Z \sim 1/j \omega C$
 - For a given ω :
 - $C_{\text{small}} \rightarrow Z_{\text{large}} = \mathbf{Z_{\text{off}}}$ (UP)
 - \rightarrow **isolation**
 - $C_{\text{large}} \rightarrow Z_{\text{small}} = \mathbf{Z_{\text{on}}}$ (DOWN)
 - \rightarrow **short circuiting of RF-signal to GND**

RF MEMS switch



Shunt capacitive switch, contd.

- Clamped-clamped beam (c-c beam)
 - **Electrostatic actuation**
↔ beam elasticity
- RF signal is **modulating** actuation voltage
 - "overlying"
- No direct contact between metal regions
 - Dielectric (isolator) in-between
 - C_{up} / C_{down} important!

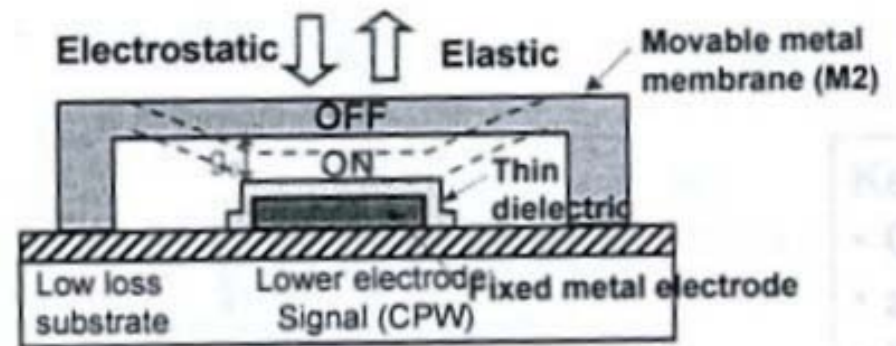

Shunt switch

- **Ideal** requirements – typical parameters
 - Shunt between t-line and GND
 - typical: 5 to 100 GHz
 - "Zero" insertion loss (up)
 - typical: -0.04 dB to -0.1 dB at 5-50 GHz
 - "Infinite" isolation
 - typical: -20 dB to -30 dB at 10-50 GHz

Capacitive switch: design parameters

- Signal lines and switches must be designed for RF
 - Suitable layouts
 - "CPW – coplanar waveguide" (horizontal)
 - "microstrip lines" (vertical)
- Switches should be compatible with IC-technology
 - Not too high actuation voltage
 - Proper spring constant
- Alternatives to electrostatic actuation:
 - Piezoelectric actuation
- Reliability $> 10^{10}$ switching cycles before failure
 - 10^9 is demonstrated

Capacitive switch: critical parameters

- **Thickness** and quality of dielectric is critical
- Choice of dielectric **material**
 - High dielectric constant:
 - Gives high ratio $C_{\text{down}} / C_{\text{up}}$
- **Charging** of the surface of the dielectric
 - C -degradation
 - Possible "stiction"
- **"Breakdown"** of dielectric
 - Becomes conductive → disaster!

Design of RF MEMS switches

- **Electromechanical** design, I
- The remaining contents of today's lecture:
 - Design parameters determining pull-in
 - Effect of dielectric
 - Roughness
 - Simplified analysis of cantilever beam
 - Elasticity
 - Deflection of beam
 - Mechanical anchoring
 - Folded springs
 - Material choice
 - Additional switch parameters

Electromechanical operation

- The operation is based on the **pull-in effect**
 - Characteristics at pull-in
 - Membrane/beam pulls in at 1/3 of gap
 - Pull-in voltage:

$$V_{PI} = \sqrt{\frac{8K}{27\epsilon_0 W w}} g_0^3$$

- Definition of parameters:
 - K spring constant
 - g_0 initial gap
 - $A=W*w$ = area

Discussion of design parameters

- V_{pi}
 - Should be low for CMOS compatibility
- $A=W*w$
 - Should be large. Size requirement is a limitation (→ compactness)
- g_0
 - Should be small. Depending of fabrication yield. Must be traded against RF performance (return loss and isolation)
- K
 - Low voltage when soft spring. Dependent on proper mechanical design. Make sure that the beam can be “released”!

$$V_{PI} = \sqrt{\frac{8K}{27\epsilon_0 W w} g_0^3}$$

Hysteresis

- A capacitive switch shows hysteresis when being switched on/off

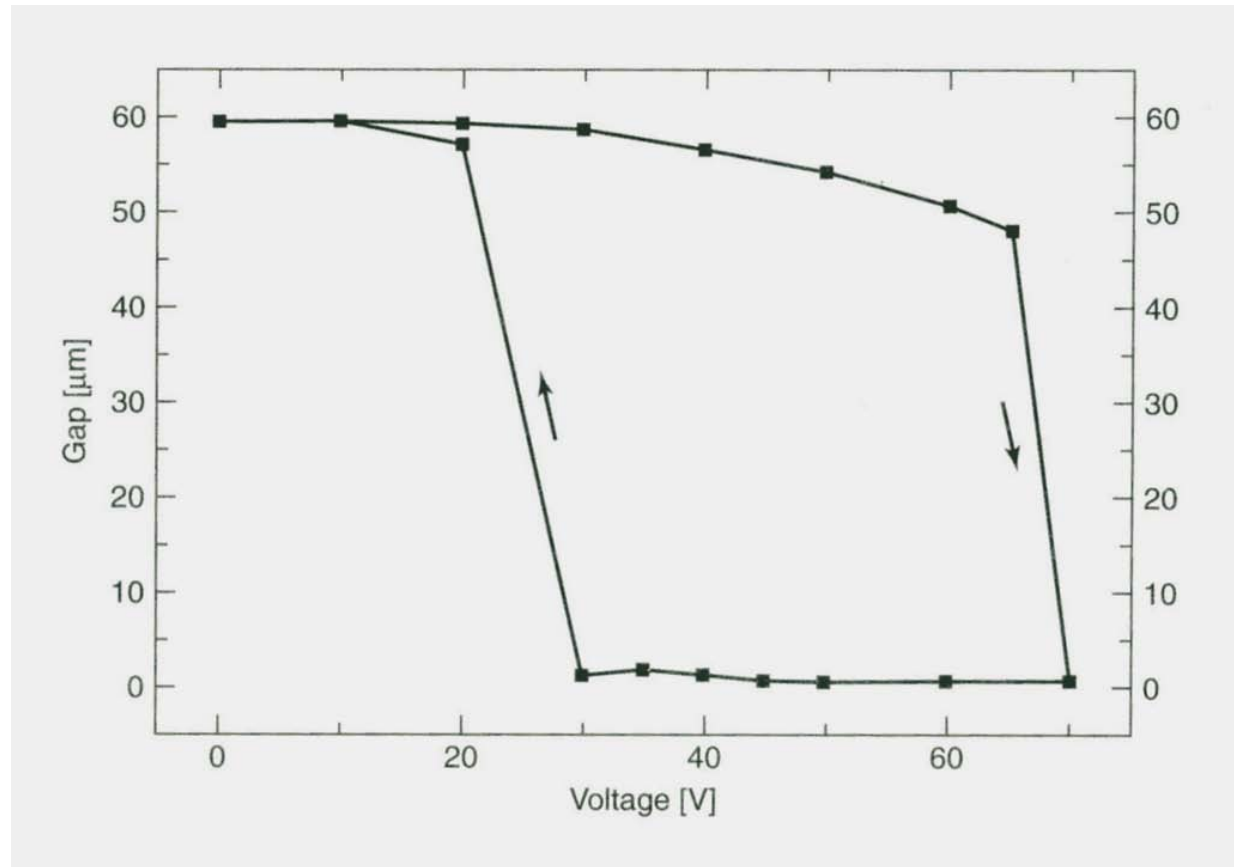

Parallel plate capacitance for shunt switch

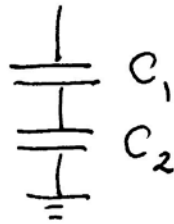

$$C_1 = \epsilon_0 \frac{A}{g}, C_2 = \epsilon_0 \epsilon_r \frac{A}{t_d}$$

$$Z = \frac{1}{sC_{up}} = \frac{1}{sC_1} + \frac{1}{sC_2}$$

$$C_{up} = \frac{1}{\frac{1}{C_1} + \frac{1}{C_2}}$$

$$C_{up} = \frac{1}{\frac{g}{\epsilon_0 A} + \frac{t_d}{\epsilon_0 \epsilon_r A}} = \frac{\epsilon_0 A}{g + \frac{t_d}{\epsilon_r}} \approx \frac{\epsilon_0 A}{g_{eff}}$$

Down-state

$$C_d = \frac{\epsilon_0 \epsilon_r A}{t_d} \quad \text{Fringe field negligible}$$

Down-state / up-state

$$\frac{C_d}{C_{up}} = \frac{\frac{\epsilon_0 \epsilon_r A}{t_d}}{\frac{\epsilon_0 A}{g_{eff}} + C_f} \approx \frac{\epsilon_r g_{eff}}{t_d} \approx \frac{\epsilon_r g}{t_d}$$

Fringe field effect

Typical value 60 - 120

Electromechanical design of RF MEMS switch (2)

Hysteresis of capacitive switch (source: H. Tilmans)

$g_0 = \text{zero-voltage gap spacing}$

$$g = g_0 - x$$

$$g_{\text{eff}} = g_0 + \frac{g_\epsilon}{\epsilon_r} \approx g_0$$

$$F_{\text{el}} = \frac{\epsilon_0 A V^2}{2g^2}$$

$$F_s = k(g_0 - g)$$

$$C_{\text{up}} = C(V=0) = \epsilon_0 \frac{A}{g_{\text{eff}}}$$

$$C_{\text{down}} = C(V > V_{\text{PI}}) = \epsilon_0 \epsilon_r \frac{A}{g_\epsilon}$$

$$\frac{C_{\text{down}}}{C_{\text{up}}} = \frac{\epsilon_r g_{\text{eff}}}{g_\epsilon} \approx \frac{\epsilon_r g_0}{g_\epsilon}$$

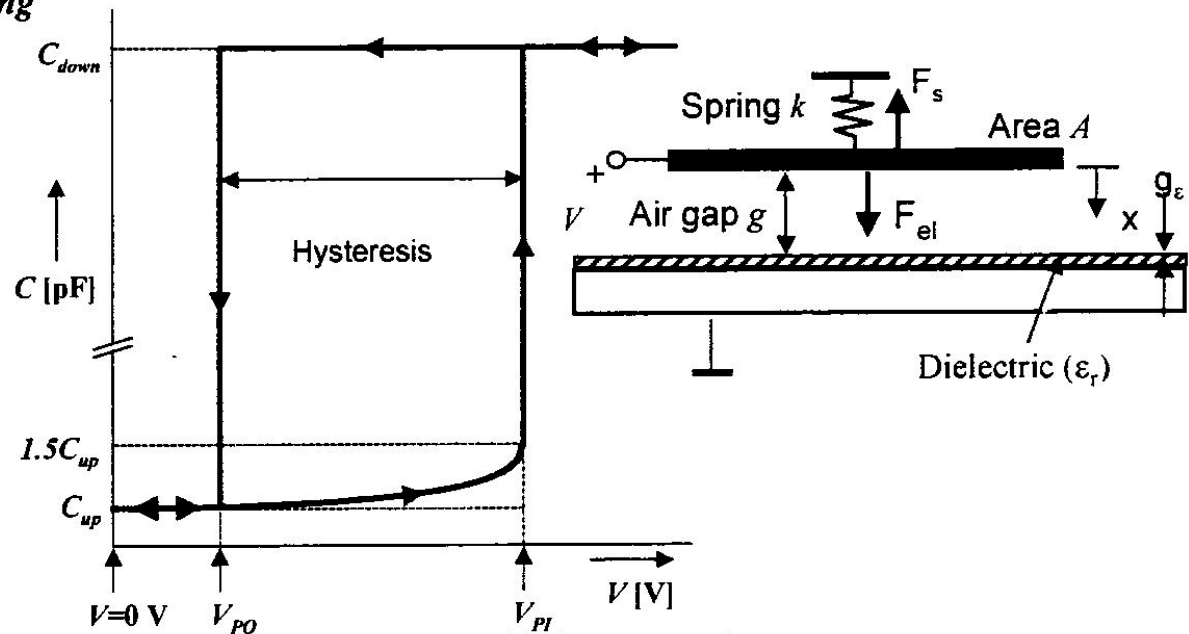

$$V_{\text{PO}} = \sqrt{\frac{2kg_0g_\epsilon^2}{\epsilon_r^2\epsilon_0A}}$$

$$V_{\text{PI}} = \sqrt{\frac{8}{27} \frac{kg_{\text{eff}}^3}{\epsilon_0A}}$$

Thickness off dielectric

- Thickness of dielectric controls the capacitance ratio $C_{\text{down}}/C_{\text{up}}$
 - **Thin layer** may give high Cd / Cu –ratio
 - Beneficial for performance
 - Problem with thin layer
 - Difficult to deposit: **"pinhole"** problem
 - In real life: min 1000 Å,
 - Should sustain high voltage without **breakdown**, 20 – 50V
 - **Dielectric materials** with higher ϵ_r give higher Cd/Cu-ratio
 - ϵ_r from 7.6 for SixNy → 40-200 for strontium-titanate-oxide
 - **PZT: $\epsilon_r > 1000!$**

Roughness

- Cd/Cu may decrease due to roughness
 - Increased roughness reduces the ratio
- Metal-to-metal: roughness degrades contact
 - Increased resistance in contact interface
- Var fig 3.26 shows effect of roughness →

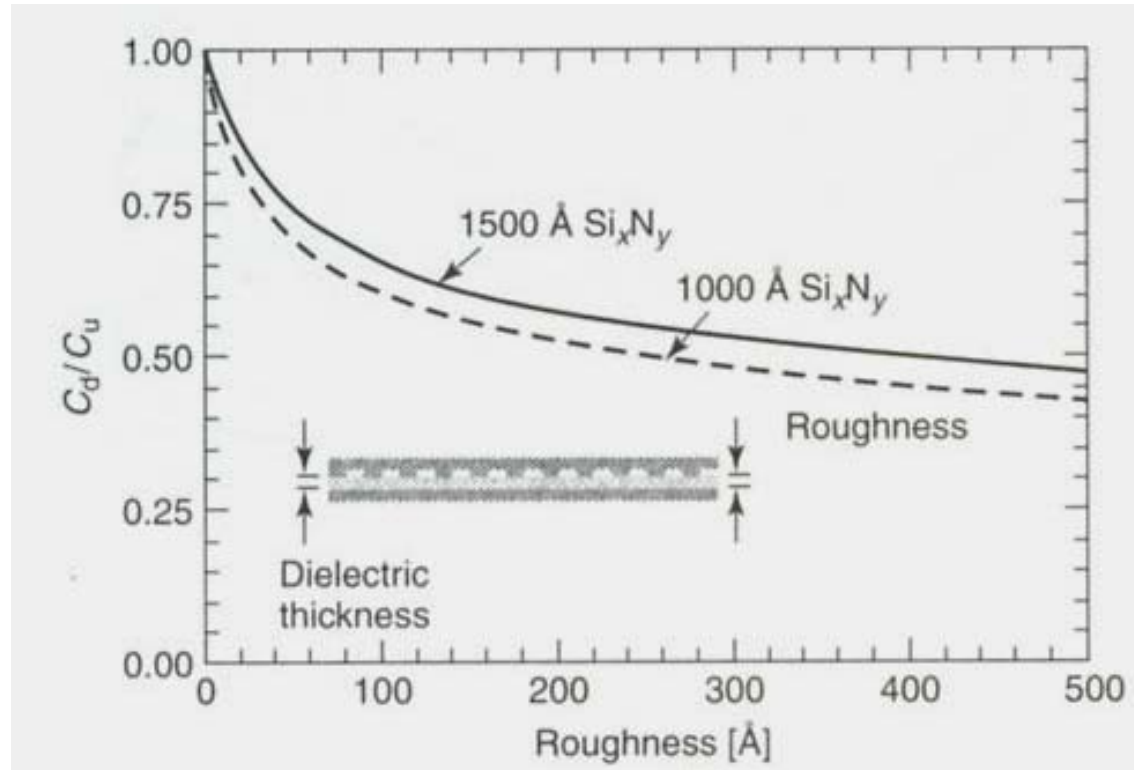

Simplified analysis of cantilever beam

- Look at interaction between **elastic** and **electrostatic** properties
- Starting with some material on **elasticity** →
 - [Slides from Arlington, Texas]

Axial Stress And Strain

Stress: force applied to surface

$$\sigma = F/A$$

measured in N/m^2 or Pa

compressive or tensile

Strain: ratio of deformation to length

$$\varepsilon = \Delta l / l$$

measured in %, ppm, or microstrain

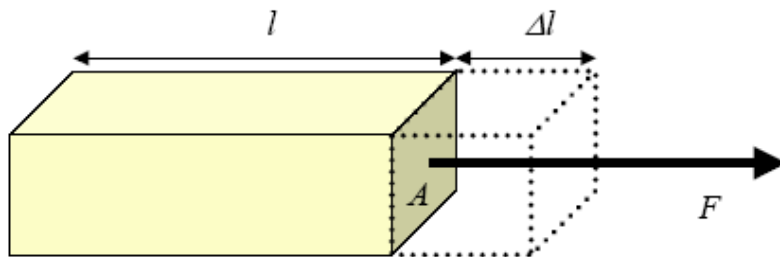
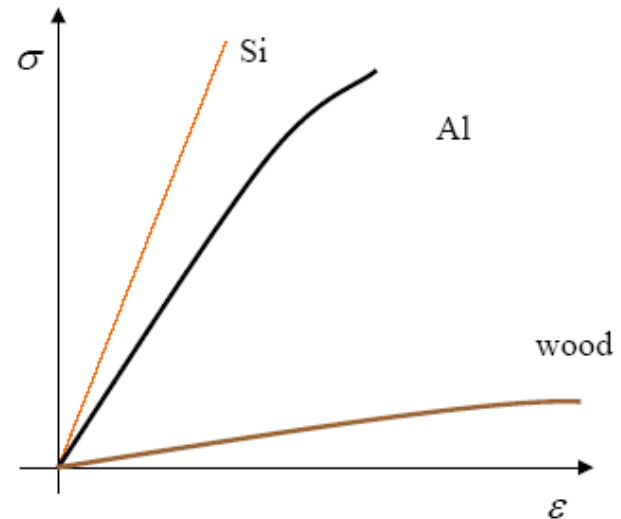

Young's Modulus:

$$E = \sigma / \varepsilon$$

Hooke's Law:

$$K = F / \Delta l = E A / l$$

Shear Stress And Strain

Shear Stress: force applied parallel to surface

$$\tau = F/A$$

measured in N/m² or Pa

Shear Strain: ratio of deformation to length

$$\gamma = \Delta l / l$$

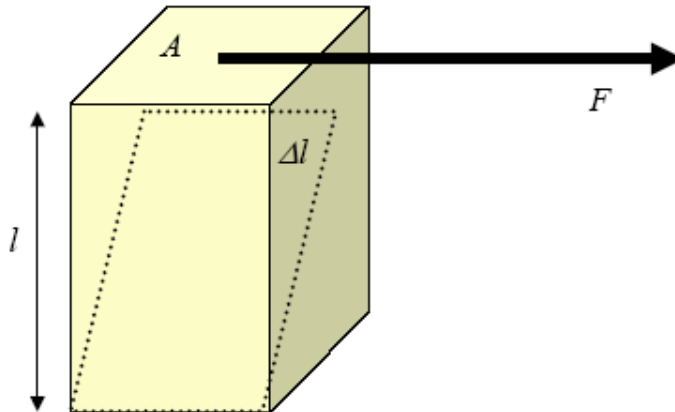

Shear Modulus:

$$G = \tau / \gamma$$

Poisson's Ratio

Tensile stress in x direction results in compressive stress in y and z direction (object becomes longer and thinner)

Poisson's Ratio:

$$\nu = - \varepsilon_y / \varepsilon_x$$

= - transverse strain / longitudinal strain

Metals: $\nu \approx 0.3$

Rubbers: $\nu \approx 0.5$

Cork: $\nu \approx 0$



Deflection of beam

- Suppose the following approximations:
 - Actuation electrode is not deflected
 - Electrostatic force concentrated at the end of the flexible beam with length L

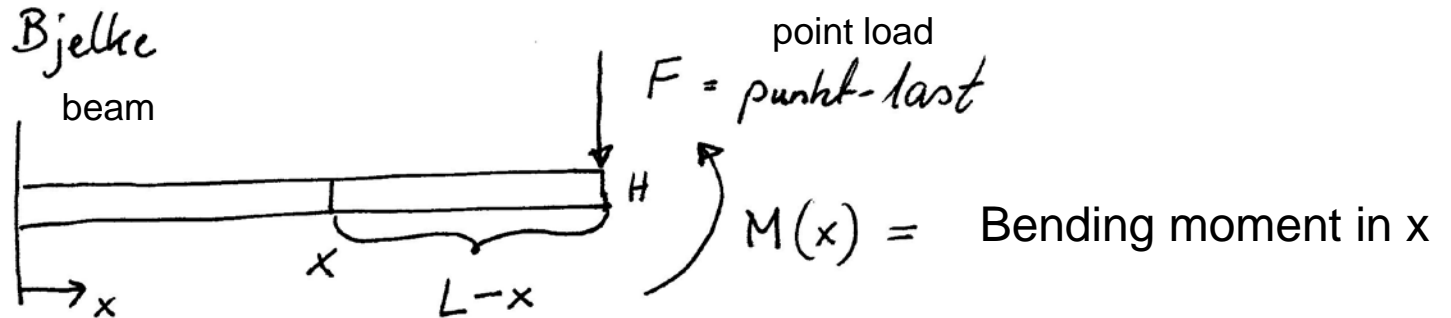

$w(x)$ = vertical displacement

W = width

Euler beam equation

$$\frac{d^2 w}{dx^2} = - \frac{M}{E \cdot I}$$

I = (area) moment of inertia

$$I = \frac{1}{12} W \cdot H^3$$

Beam equation $\frac{d^2 w}{dx^2} = - \frac{M}{E \cdot I}$

Moment of inertia $I = \frac{1}{12} W \cdot H^3$

Bending moment
(force * arm) $M(x) = -F(L-x)$

$$\frac{d^2 w(x)}{dx^2} = \frac{F}{E \cdot I} (L-x)$$

$$w(0) = 0$$

Boundary conditions

$$\frac{dw(0)}{dx} = 0$$

Suppose a solution

$$w(x) = A + Bx + Cx^2 + Dx^3$$

$$\frac{dw(x)}{dx} = B + 2Cx + 3Dx^2$$

$$\frac{d^2w(x)}{dx^2} = 2C + 6Dx$$

Boundary conditions

$$w(0) = 0 \quad \Rightarrow \quad A = 0$$

$$\frac{dw(0)}{dx} = 0 \quad \Rightarrow \quad B = 0$$

$$w(x) = \frac{FL}{2EI} x^2 \left(1 - \frac{x}{3L} \right)$$

$$w(x) = \frac{FL}{2EI} x^2 \left(1 - \frac{x}{3L}\right)$$

Max. deflection at $x = L$

$$w(L) = \frac{L^3}{3EI} \cdot F$$

Beam stiffness represents a spring with spring constant $k_{\text{cantilever}}$

Compare with

$$F = k_{\text{cantilever}} \cdot \underbrace{\Delta W}_{w_{\text{max}}}$$

$$k_{\text{cantilever}} = \frac{F}{w(L)} = \frac{3EI}{L^3} = \frac{1}{4} E \cdot W \left(\frac{H}{L}\right)^3$$

Spring constant

$$k_{\text{cantilever}} = \frac{F}{w(L)} = \frac{3EI}{L^3} = \frac{1}{4} E \cdot W \left(\frac{H}{L}\right)^3$$

For a **double clamped** beam we have (Varadan p. 132)

$$k_{cc} = 16 E \cdot W \left(\frac{H}{L}\right)^3$$

Beam equation for distributed force

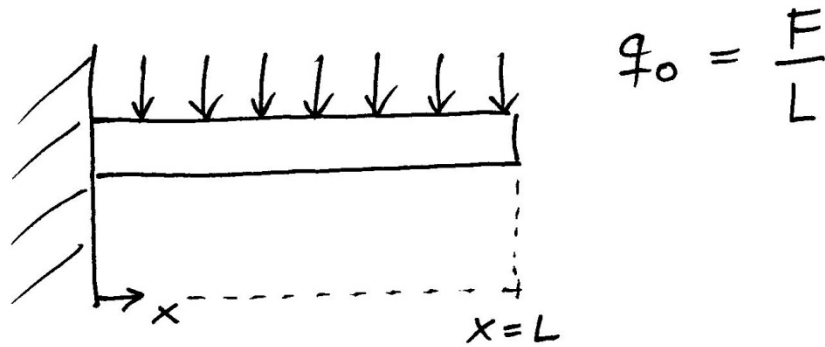

$$EI \cdot \frac{d^4 w(x)}{dx^4} = q_0$$

$$\begin{aligned} w(0) &= w'(0) = 0 \\ w''(L) &= w'''(L) = 0 \end{aligned}$$

$$\Rightarrow w(x) = \frac{q_0}{24EI} x^2 (x^2 + 6L^2 - 4Lx)$$

$$w(L) = \frac{q_0}{8EI} L^4 = \frac{F}{8EI} L^3$$

$$k_{\text{cantilever}} \approx \frac{F}{w(L)} = \frac{8EI}{L^3} = \frac{2}{3} EW \left(\frac{H}{L} \right)^3$$

c-c-beam

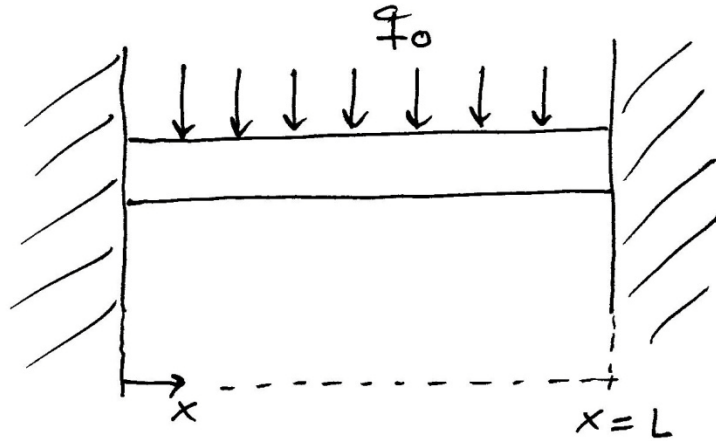

$$EI \cdot \frac{d^4 w(x)}{dx^4} = q_0$$

$$\begin{aligned} w(0) &= w'(0) = 0 \\ w(L) &= w'(L) = 0 \end{aligned}$$

$$\Rightarrow w(x) = \frac{q_0}{24EI} x^2 (x^2 - 2Lx + L^2)$$

$$w\left(\frac{L}{2}\right) = \frac{q_0}{24EI} \cdot \frac{L^4}{8} = \frac{F}{24EI} \cdot \frac{L^3}{8}$$

$$k_{c-c} \approx \frac{F}{w\left(\frac{L}{2}\right)} = \frac{24 \cdot 8 \cdot EI}{L^3} = 16 EI \left(\frac{H}{L}\right)^3$$

Mechanical anchoring

- **Folded springs** are often used
- Why?
 - To obtain low actuation voltage ($< 5V$) for mobile communication systems
- **→ Folded springs give low K on a small area**

Reduced actuation voltage

- Actuation voltage
 - "pull-down" needed
 - Should be $<$ tens of V
- Membrane should not be too stiff
 - **Use meanders**
 - Folded spring has lower k
 - **Area effective!**

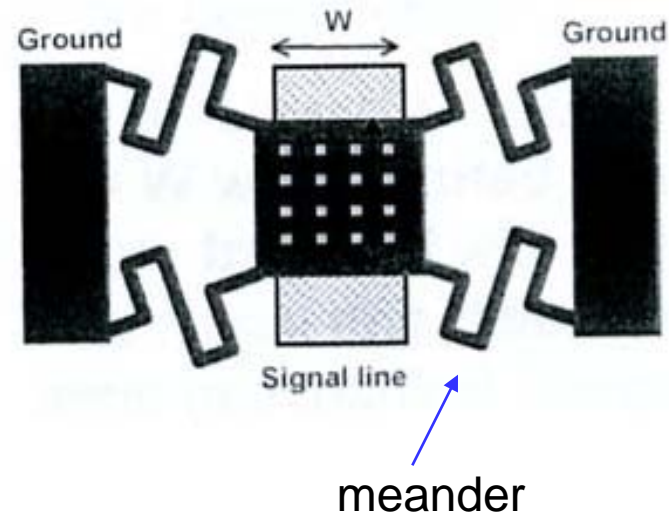

Different folded springs

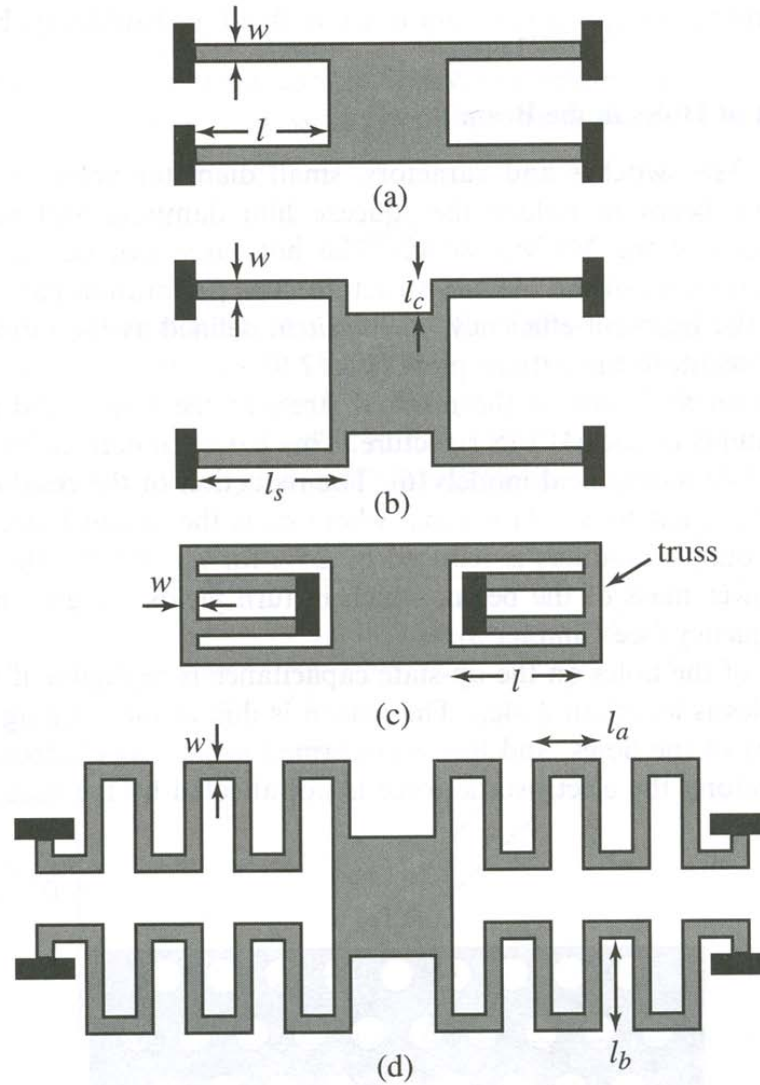

Rebeiz fig. 2.10

Electromechanical design of RF MEMS switch (3)

• Suspension (arm) folded design

Low voltage operation (<5V) for mobile communication applications requires folded suspension design: low-k in small area

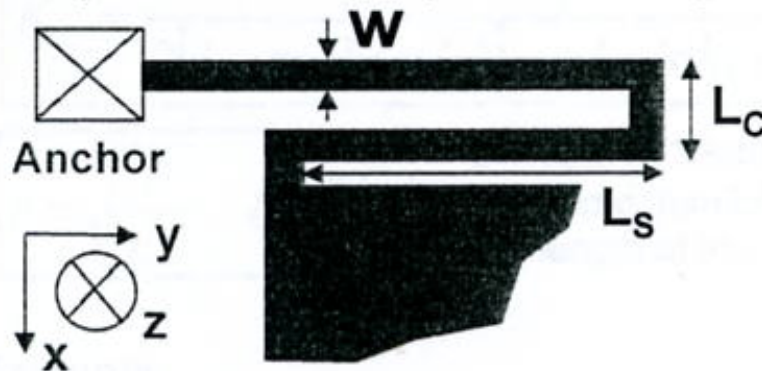

L_s : span beam length

L_c : connector beam length

w : width

t : metal thickness

E : Young's modulus

ν : Poisson's ratio

$$k_z = \frac{\left(\frac{Ew}{2}\right)\left(\frac{t}{L_c}\right)^3}{1 + \frac{L_s}{L_c} \left[\left(\frac{L_s}{L_c}\right)^2 + 12 \frac{1+\nu}{1+(w/t)^2} \right]} \Bigg|_{L_s \gg L_c} \rightarrow 2Ew \left(\frac{t}{L_s}\right)^3$$

Independent of ν

$$k_x = 2Et \left(\frac{w}{L_c}\right)^3$$

$$k_y = 2Et \left(\frac{w}{L_s}\right)^3$$

30

Spring materials?

- **Metal or polysilicon: case study (one) serpentine spring**

$L_s=220\mu\text{m}$, $L_c=18\mu\text{m}$, $t=2\mu\text{m}$, $w=6\mu\text{m}$

Au	Al	Polysilicon
$E_{\text{Au}} \sim 80\text{GPa}$	$E_{\text{Al}} \sim 70\text{GPa}$	$E_{\text{Si-poly}} \sim 170\text{GPa}$
$\nu_{\text{Au}} \sim 0.22$	$\nu_{\text{Al}} \sim 0.3$	$\nu_{\text{Si-poly}} \sim 0.3$

Elastic constant $K_z (= 4k_z)$

$K_{z\text{Au}} = 0.721\text{N/m}$ $K_{z\text{Al}} = 0.631\text{N/m}$ $K_{z\text{poly}} = 1.533\text{N/m}$

Elastic constant K_x

$K_{x\text{Au}} = 1.19 \times 10^4\text{N/m}$ $K_{x\text{Al}} = 1.04 \times 10^4\text{N/m}$ $K_{x\text{poly}} = 2.52 \times 10^4\text{N/m}$

Elastic constant K_y

$K_{y\text{Au}} = 6.49\text{N/m}$ $K_{y\text{Al}} = 5.68\text{N/m}$ $K_{y\text{poly}} = 13.79\text{N/m}$

Estimated V_{PI} (area = $100 \times 100 / 20 \times 20 \mu\text{m}^2$, 2 μm -gap):

$V_{\text{PIAu}} = 4.4\text{V}/21.9\text{V}$ $V_{\text{PIAl}} = 4.1\text{V}/20.6\text{V}$ $V_{\text{PIpoly}} = 6.4\text{V}/32\text{V}$

Spring materials, contd.

- Summary
 - Metal seems to be a better choice for RF MEMS spring structures than polySi
 - Metal has lower actuation voltage (+)
 - Metal has lower resistivity (+)
 - BUT: PolySi is stiffer
 - Higher spring constant (+)
 - Mechanical release force is larger (+)
 - **”stiction” avoided!**
 - Higher actuation voltage (÷)
 - Might not be CMOS compatible

Additional switch parameters

- **Bandwidth**

- An upper limit is usually specified
 - Resistances and parasitic reactances influence the value

- **Resonance frequency**

- Specifies the frequency where the switch “resonates”
- Resonance when potential and kinetic energy are “equal”
 - $j\omega L = -1/j\omega C$
 - E.g. reactances are of equal magnitude
 - Frequency depends on k and m $\rightarrow 1/C$ and L
- Operational bandwidth should be **outside** the frequency of natural resonance mode
- \rightarrow Limits minimum or maximum **switching speed**

Additional switch parameters, contd.

- **Phase and amplitude "tracking" and "matching"**
 - Specifies how well the signal keeps the "shape"
 - Important for "multi-throw" switches
 - Each branch may have different length and loss, giving phase and amplitude differences
- **"Intercept" point**
 - Specifies when distortion of output power versus input power "starts"
- **Switch transients**
 - Voltage transients at input/output due to changes in actuation voltage

Additional switch parameters, contd.

- **Life cycle** and degradation
 - Influences from the environment
 - Fatigue fracture
 - This aspect is important for all parts containing **movable structures!**