

# INF 5490 RF MEMS

## **LN07: RF MEMS phase shifters Resonators, I**

Spring 2011, Oddvar Søråsen  
Jan Erik Ramstad  
Department of Informatics, UoO

# Today's lecture

- Phase shifters
  - Function
  - Applications
  - Technology
  - Analog phase shifters
  - Digital phase shifters
- Mechanical resonators
  - Basic principles
  - **Operating principles** for basic resonator structures

# Function

- A phase shifter is a 2-port

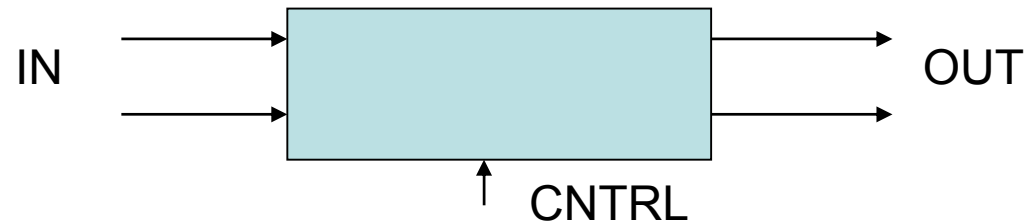

- Output signal is **delayed** relative to the input signal
- The effective "**path-length**" of the transmission line can be changed
  - Signal propagates a longer distance → "delayed" → phase change
  - Phase difference can be controlled by a DC bias

# Important (desired) properties

- Continuous tunability
- Low loss
- Impedance matching of signal
- High power signal capacity
- Low power control bias
- Fast response
- Low cost

# Applications

- "Phased array" antenna may have thousands of elements with a phase shifter for every element
  - Antenna beam can be **steered** in space without physically moving the antenna
  - Antenna beam can be **shaped**
- Use of MEMS phase shifters is a hot topic
  - Can be integrated with antenna elements on ceramic or quartz substrates
  - → Low-cost-antennas

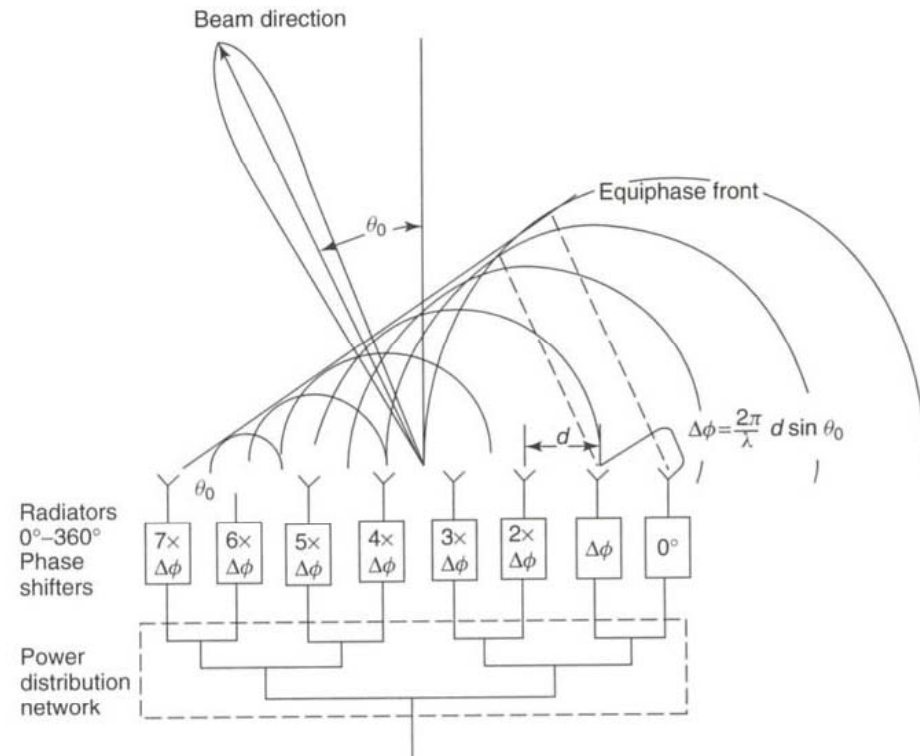

Figure 6.1 Principle of a phased array antenna using phase shifters. Varadan *et al.* 1995

# Classifications

- Phase shifters are classified as
  - Analog
    - Continuous phase shift
    - Change of signal propagation speed
  - Digital
    - Phase shift in discrete steps
    - Select different signal paths

# Technology

- Different electronically controllable phase shifters exist
  - Ferrite phase shifters
  - Semiconductor (solid state) phase shifters
  - → MEMS phase shifters

# Ferrite phase shifters

- Phase shift set by a change of external magnetic field
  - Magnetic field interacts with electron-spin and influences **magnetic permeability =  $\mu$**
  - Propagation speed of electromagnetic waves is changed

$$v_p \approx \frac{1}{\sqrt{\mu}}$$

- $\rightarrow$  gives variable phase shift
- + Good properties, high power capability
- - High cost, complex, not practical for high integration systems



# Semiconductor phase shifters

- Switching in/out different line segments by using IC **switches**
  - PIN-diode, GaAs FET
- + Cheap, small, monolithic integration with amplifiers is possible
- - Can not give continuous phase variation
- - Significant RF loss, high insertion loss
- - Poor power capability

# MEMS phase shifters

- **A. Use of distributed, capacitive shunt-switches (analog)**
  - Change the effective **capacitive load** of transmission line
  - Continuous phase change

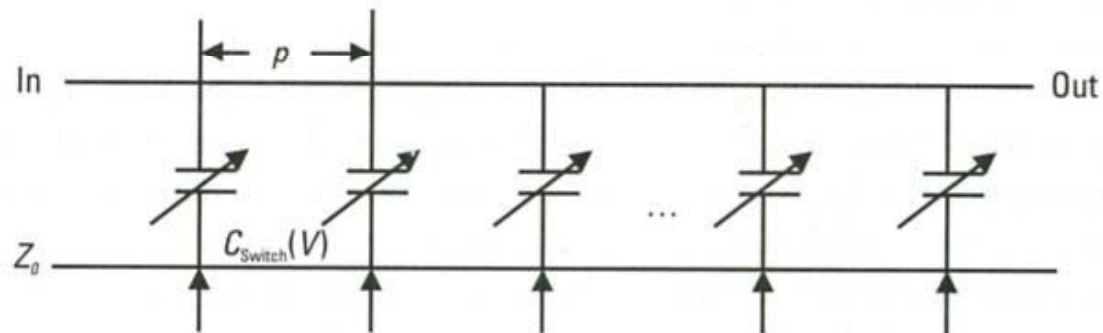

[De Los Santos]

# MEMS phase shifters, cont.

- **B. Based on MEMS switches (digital)**
  - Phase shift set by switching between different paths
  - Discrete phase change

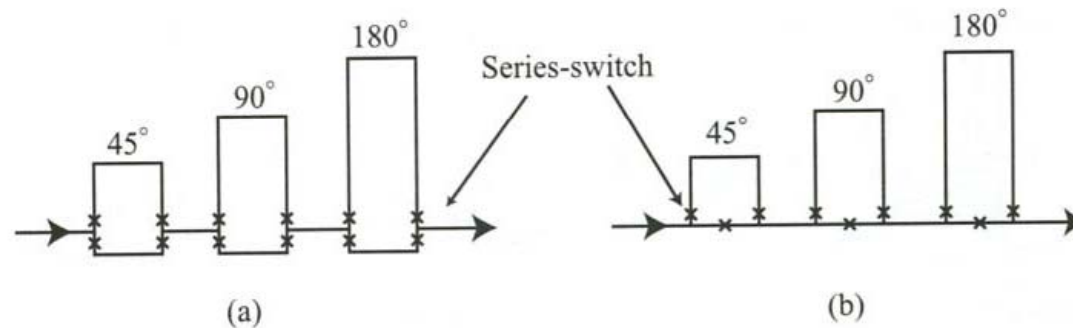

- MEMS **switches** have high performance!
  - Better properties than semiconductor switches
- → **High-performance phase shifters are possible!**

# Propagation in a transmission line

Voltage wave in positive z-direction  
(R,L,G,C per length)

$$V(z) = V^+ e^{-kz}$$

$$k = \sqrt{(R + j\omega L)(G + j\omega C)}$$

Lossless line

$$R = G = 0 \Rightarrow k = j\omega\sqrt{LC} = j\beta$$

$$V(z) = V^+ e^{-j\beta z}$$

$$V(z, t) = V_0 \cos(\omega t - \beta z)$$

The wave repeats in space when

$$\beta \cdot z = 2\pi \Rightarrow z = \lambda = \frac{2\pi}{\beta}$$

Propagation velocity =  
phase velocity,  $V_p$

$$v_p \cdot T = \lambda \Rightarrow v_p = \frac{2\pi}{T} \cdot \frac{1}{\beta} = 2\pi f \frac{1}{\omega\sqrt{LC}} = \frac{1}{\sqrt{LC}}$$

Characteristic impedance

$$Z_0 = \sqrt{\frac{L}{C}}$$

# Analog phase shifters

- Phase velocity for a transmission line

$$v_p = \frac{1}{\sqrt{L_t \cdot C_t}}$$

- Variables are inductance and capacitance **per unit length**
- Idea: C-value can be controlled by a bias voltage
  - The result is a **shunt capacitive loaded transmission line**

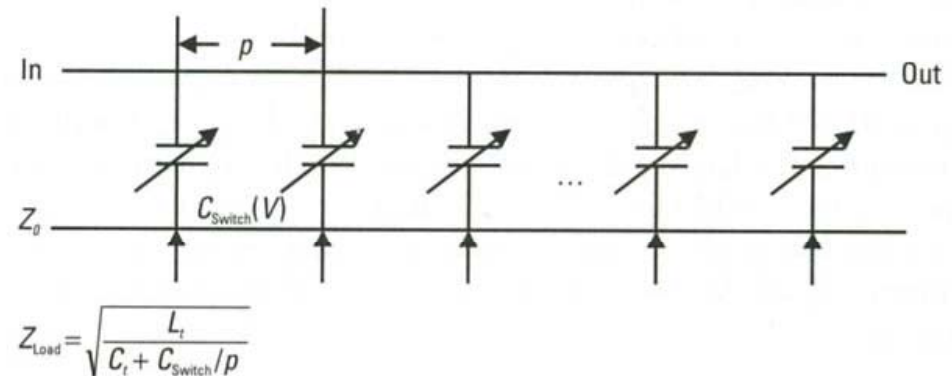

Figure 5.1 Schematic of analog phase shifter.

[De Los Santos]

$C_t$  = line capacitance

# Shunt capacitive loaded line

- Transmission line (TL) **periodic** loaded with **variable capacitors**
- Working principle
  - $C_t$  increases  $\rightarrow v_p$  decreases  $v_p = \frac{1}{\sqrt{L_t \cdot C_t}}$
  - It will take a longer time for the signal to propagate a given distance
- All  $C_{\text{switch}}$  capacitors change at the same time with a continuous phase shift by tuning the bias voltage
- A challenge for analog phase shifters:
  - Sensitive to **noise** on bias voltage line

# Distributed MEMS phase shifters

- **Capacitive shunt switches** loading the line
  - Beam over centre electrode in a co-planar wave guide, CPW
  - Beam pulled down by a electrostatic force controlled by DC voltage relative to the bottom electrode (< pull-down voltage!)
  - Gap determines the distributed MEMS-capacitance
    - "loaded" TL-impedance changes
  - Can be modeled by simple analytical expressions
  - Good for broad bandwidth signals

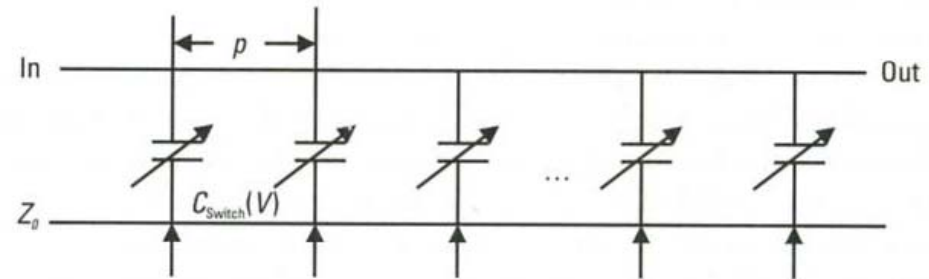

- Periodic loading by shunt capacitors gives a **"Bragg-frequency"** limiting the maximum frequency of operation ("grating" effect)

# Formulas for lossless and loaded lines

## Lossless line

$\epsilon$  = dielectric constant

$\mu$  = magnetic permeability

$$Z_0 = \sqrt{\frac{\mu}{\epsilon}}$$

$$v_p = \frac{1}{\sqrt{\epsilon\mu}} = \frac{1}{\sqrt{\epsilon_0\epsilon_r\mu}} \approx \frac{1}{\sqrt{\epsilon_r}} \cdot \frac{1}{\sqrt{\epsilon_0\mu_0}} = \frac{c}{\sqrt{\epsilon_r}}$$

Time delay per section

$$\tau = \frac{p}{v_p} = \frac{p\sqrt{\epsilon_r}}{c}$$

## Loaded line

$$Z_{0\_loaded} = \sqrt{\frac{L}{C + C_{switch}/p}}$$

$$v_{p\_loaded} = \frac{1}{\sqrt{L \cdot (C + C_{switch}/p)}}$$

$$\tau_{loaded} = \frac{p}{v_{p\_loaded}} = \sqrt{pL \cdot (pC + C_{switch})}$$

Time delay per section

$$Z_0 = \sqrt{\frac{L}{C}} \Rightarrow L = Z_0^2 \cdot C$$

$$v_p = \frac{1}{\sqrt{LC}} = \frac{1}{Z_0 C}$$

$$C = \frac{1}{v_p Z_0} = \frac{\sqrt{\epsilon_r}}{c Z_0}$$

$$L = Z_0^2 C = \frac{Z_0 \sqrt{\epsilon_r}}{c}$$



# Challenges for MEMS shunt-switch phase shifters

- Low switch speed ( $\mu\text{s}$ )  $\rightarrow$  slow adaptation to given delay
- High actuation voltage,  $V_s = 20 - 100 \text{ V}$ 
  - $V_s$  reduced by **reducing the gap**
    - Complex fabrication (yield)
    - Parasitic up-state capacitance contributes significantly
    - More sensitive to pull-in
  - $V_s$  reduced by using materials with **lower Youngs modulus**
    - Use polymers ( $E = 5 \text{ GPa}$ , metals have  $50 - 100 \text{ GPa}$ )
    - Polymers can give 1/3 actuation voltage compared with metals
    - How to use micro stereo lithography to fabricate such structures is described in Varadan (not syllabus)
- **$\rightarrow$  Good enough properties for phased array antennas**

# Digital phase shifters with series-switches

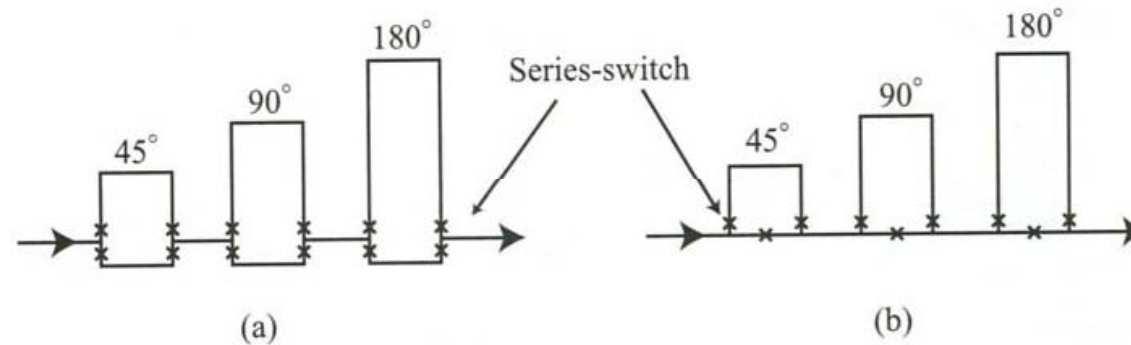

- Working principle
  - Different line paths switched in/out
  - Interconnections through switches
- Switches for "180°, 90°, 45°, 22.5°, 11.25° -sections in a cascade arrangement
- Several bits used
  - Controlling line sections individually
  - F.ex. 3 bits: 45/90/180° give phase shift 0, 45, 90, 135, ... , 315°
  - 3 bit and 4 bit phase shifters have been demonstrated

# Digital MEMS phase shifters

- **Based on MEMS switches**
- MEMS **switches** have **high performance!**
  - Negligible actuation power
  - Negligible standby power consumption
  - Low insertion loss
  - High isolation
  - Limited speed, 1 – 30  $\mu\text{s}$ 
    - Not always critical

# Rockwell's 35 GHz MEMS phase shifter

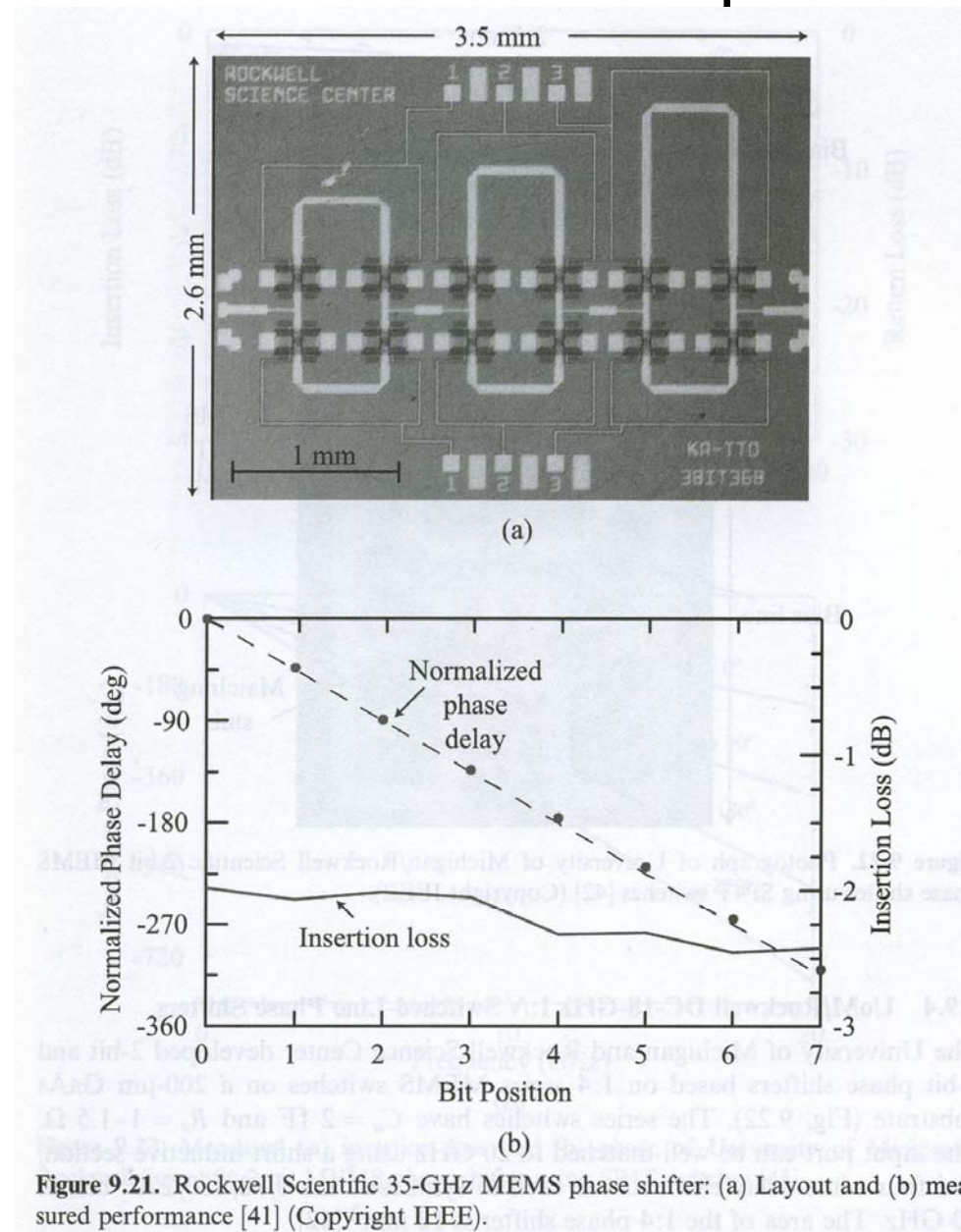

# Main types of digital phase shifters (De Los Santos)

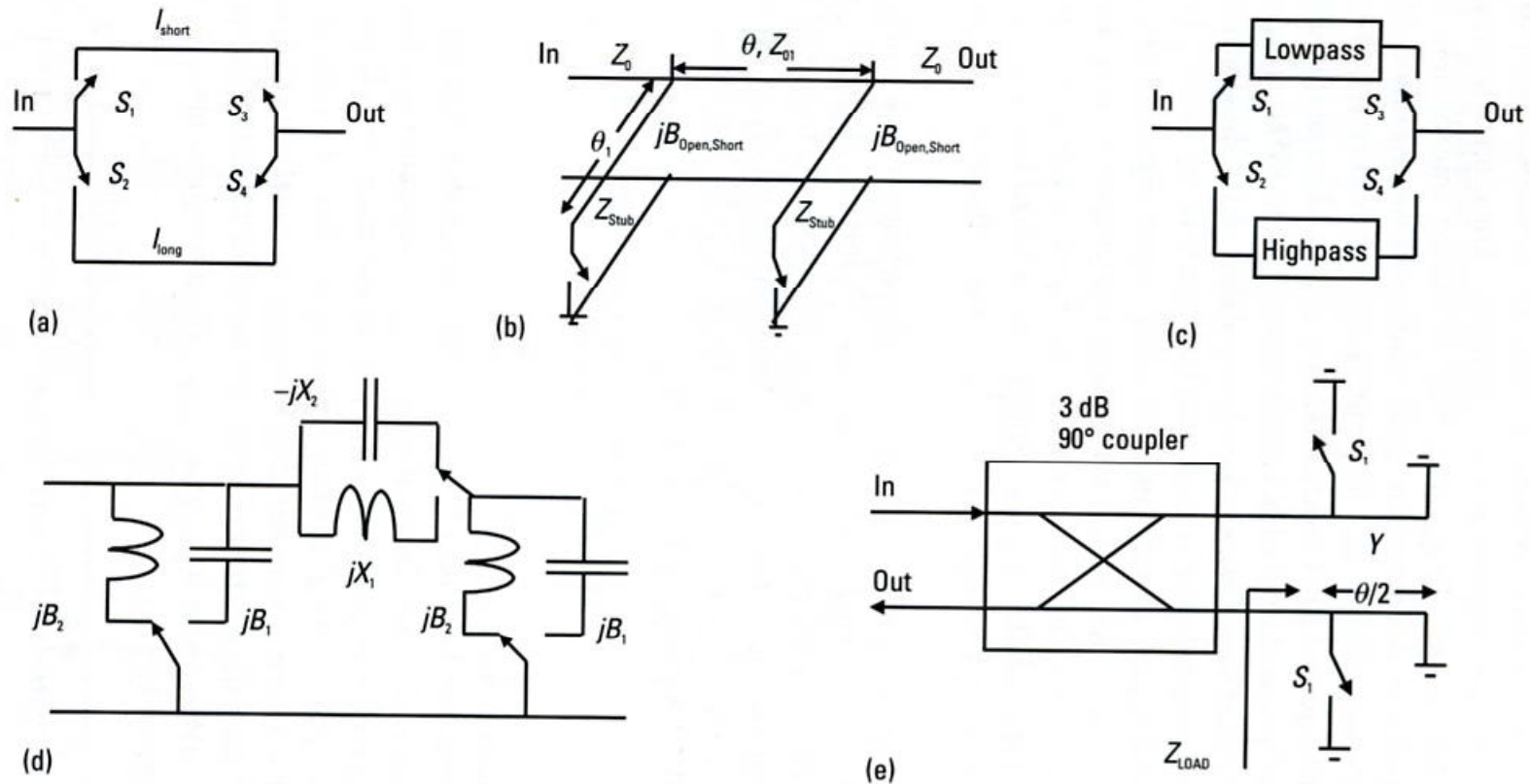

**Figure 5.2** Schematic of 1-bit digital phase shifters: (a) switched line, (b) loaded line, (c) switched lowpass-/highpass-filter concept, (d) switched lowpass-/highpass-filter LC implementation, and (e) reflection.  $Y$  is the characteristic admittance of the short-terminated line of length  $\theta/2$ .

# Digital phase shifters, contd.

- **Switched line**

- Single-pole double throw (SPDT)
- Differential phase shift given by

$$\Delta\varphi = \beta(l_{long} - l_{short})$$

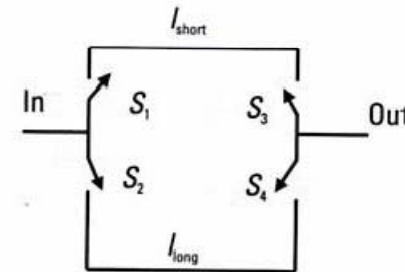

- **Loaded line**

- Switchable stubs introduced
  - Give contribution to phase shift
- Each stub is terminated by a switch to ground
  - Phase shift depending on the existing/non-existing ground connection

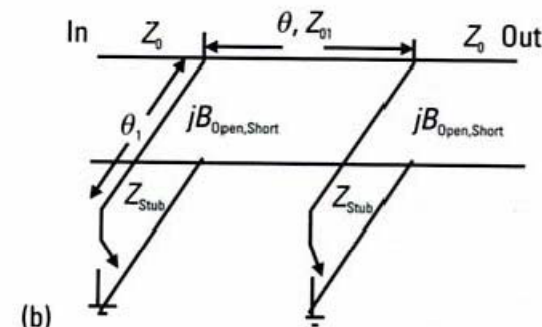

# Digital phase shifters, contd.

- **Switched LP/HP –filter**

- Use dual lumped LC-circuits
- Choose between two circuits with different phase delays
  - LP = phase delay
  - HP = phase advance
  - Input/output impedance can be chosen to  $Z_0$
- Phase shift between the two settings can be calculated
- Compact implementation possible

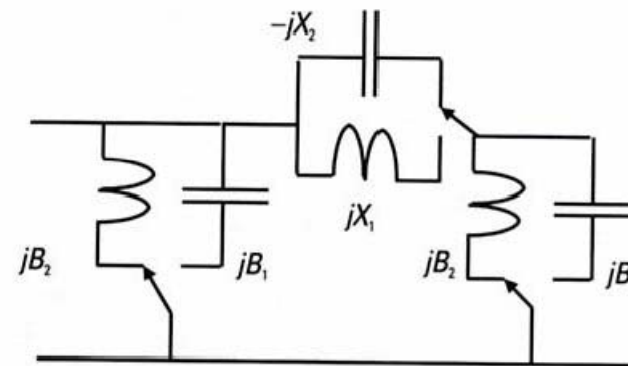
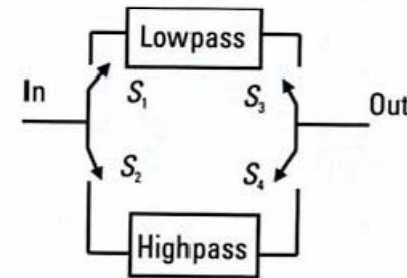

# Reflection type phase shifters

- Two-port terminated by short-circuited transmission lines with electrical length

$$\Delta\phi/2$$

- If MEMS switches are connected to ground: *The termination will reflect the signal with a smaller delay than if the switches were open*
- Two equal terminations  $\rightarrow$  the lines are balanced
- A special **Lange coupler** is used
  - The signals are reflected and added in phase at the output port ("short circuit termination")

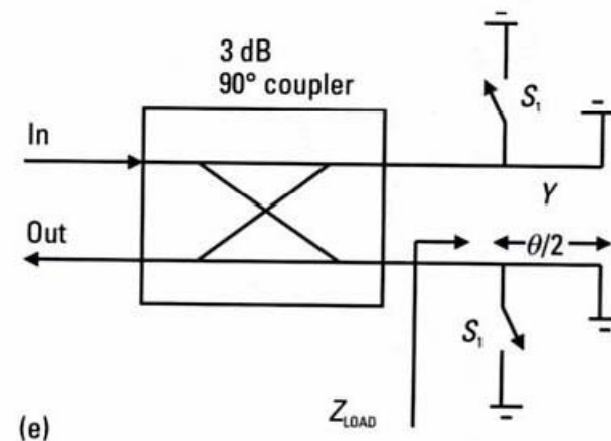



# Reflection type phase shifter, N-bit

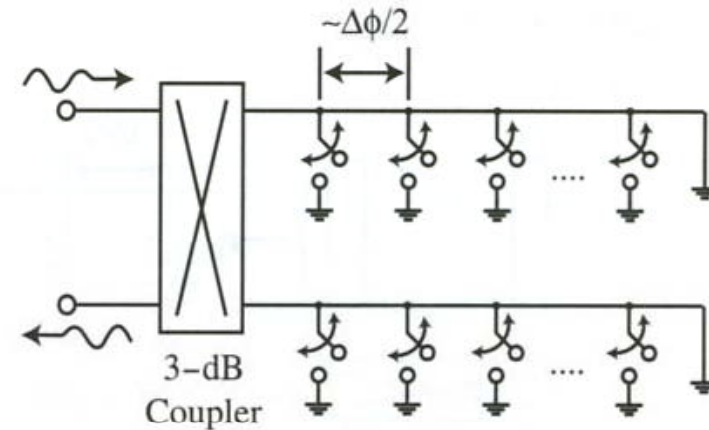

(a)

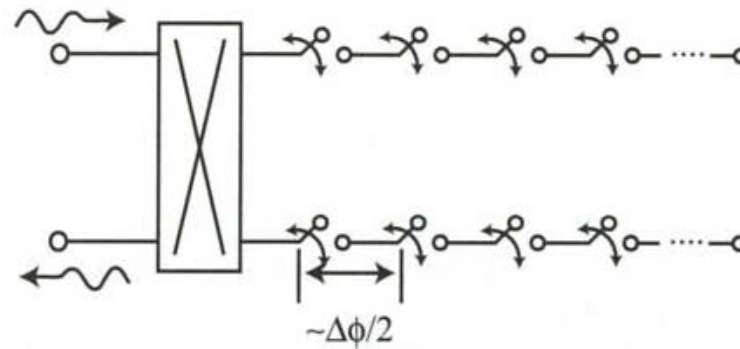

(b)

Figure 9.1. A reflect-line  $N$ -bit phase shifter using (a) shunt and (b) series switches.

# Reflection type phase shifters, contd.

- Properties
  - Electric distance between switches is half the lowest bit resolution
  - Reflection type phase shifters have **small dimensions**
    - Give double phase delay per unit length compared to switched line topology

# 2 bit distributed phase shifter

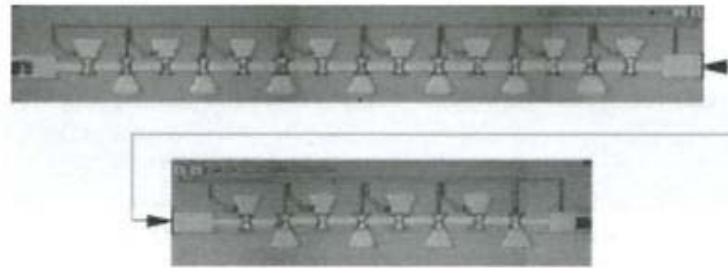

(a)

Choose upper and/or lower section

Each section implemented by shunt capacitive line

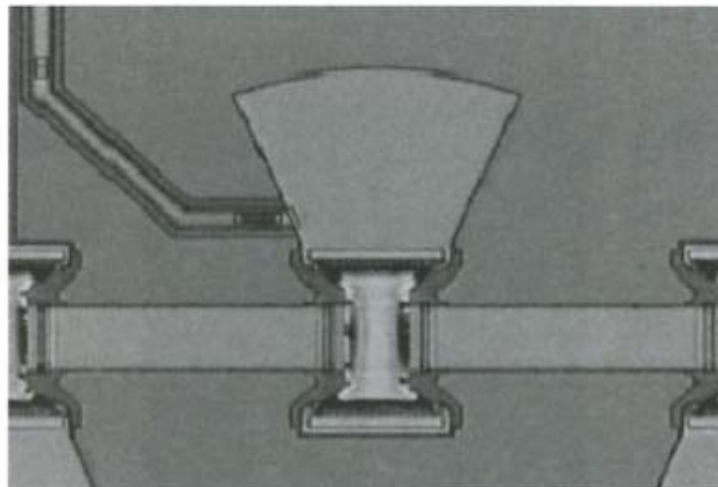

(b)

**Figure 6.8** Photograph of (a) the two-bit  $180^\circ$  phase shifter on top and  $90^\circ$  on the bottom; (b) single MEMS section. Reproduced from J.S. Hayden, A. Malczewski, J. Kleber, C.L. Goldsmith and G.M. Rebeiz, 2001, '2 and 4-Bit DC-18 GHz microstrip MEMS distributed phase shifters', in *Proceedings of IEEE MTT-S International Microwave Symposium*, IEEE, Washington, DC: 219–222, by permission of IEEE, © 2001 IEEE

# Today's lecture

- Phase shifters
  - Functionality
  - Applications
  - Technology
  - Analog phase shifters
  - Digital phase shifters
- Mechanical resonators
  - Basic principles
  - **Operating principles** for basic resonator structures

# Mechanical resonators

- Basic **principles**
- Various types of resonators
- Typical properties
  
- **Working principle** for
  - Comb-resonator
  - Clamped-Clamped (c-c) beam resonator
  - "free-free (f-f) beam" resonator

# Basic principles

- Simple oscillating mechanical system: **mass/spring with damping**
  - Amplitude increases when  $f \rightarrow f_r$ 
    - Large oscillations close to the natural resonance frequency (non-damped resonance frequency)
  - Limited by damping
  - Electrical equivalents, 2 types: series or parallel combination of C, L and R (small)
  - Resonance when reactances cancel each other
  - Can calculate resonance frequency from the s-polynomial for the oscillating circuit

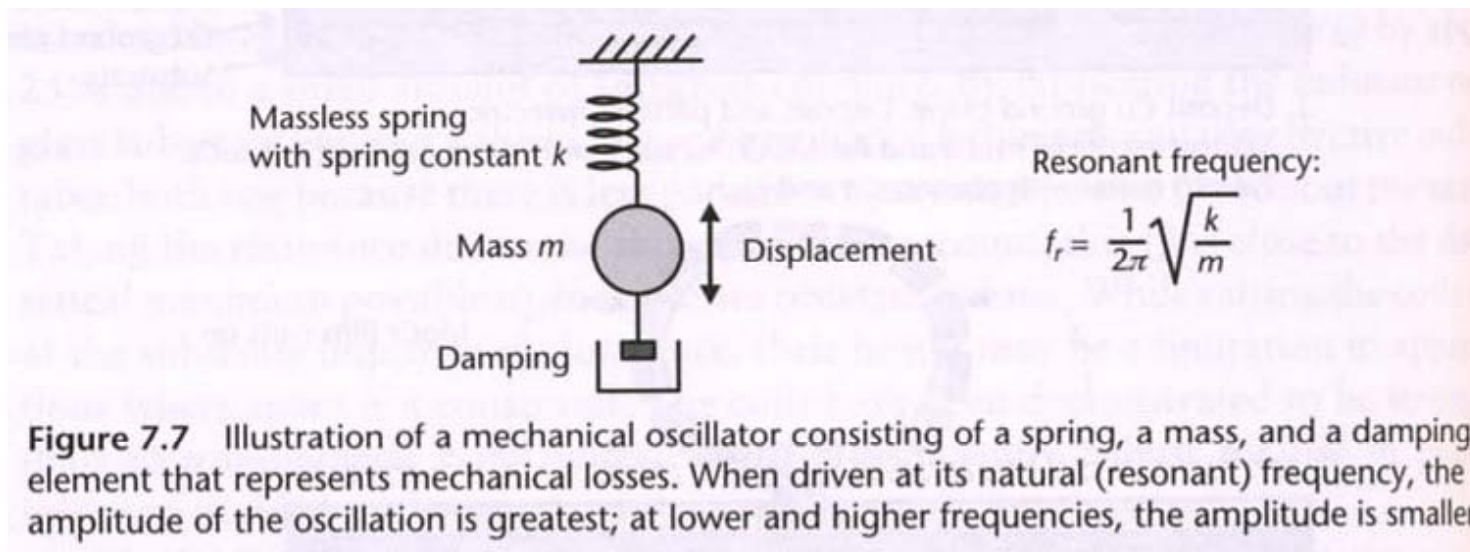

# Q-factor for oscillating circuits

- Q-factor limited by resistive loss
- High Q gives large displacement at resonance frequency
  - Higher peak, smaller bandwidth

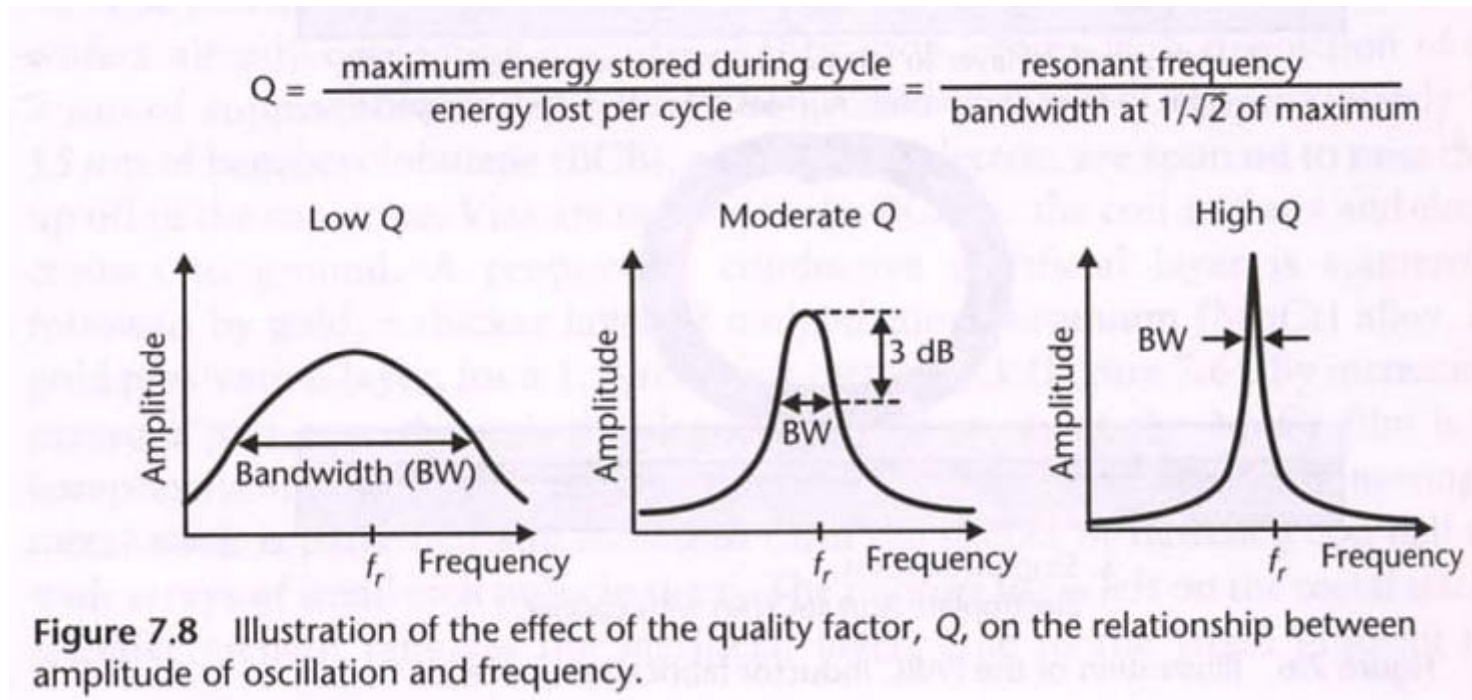

# Today's resonators

- **Quartz crystals** used a lot
  - $Q \rightarrow 10,000$
- RCL-resonators
  - $Q < 1,000$
  - Resistive, parasitic loss



# Different resonator types

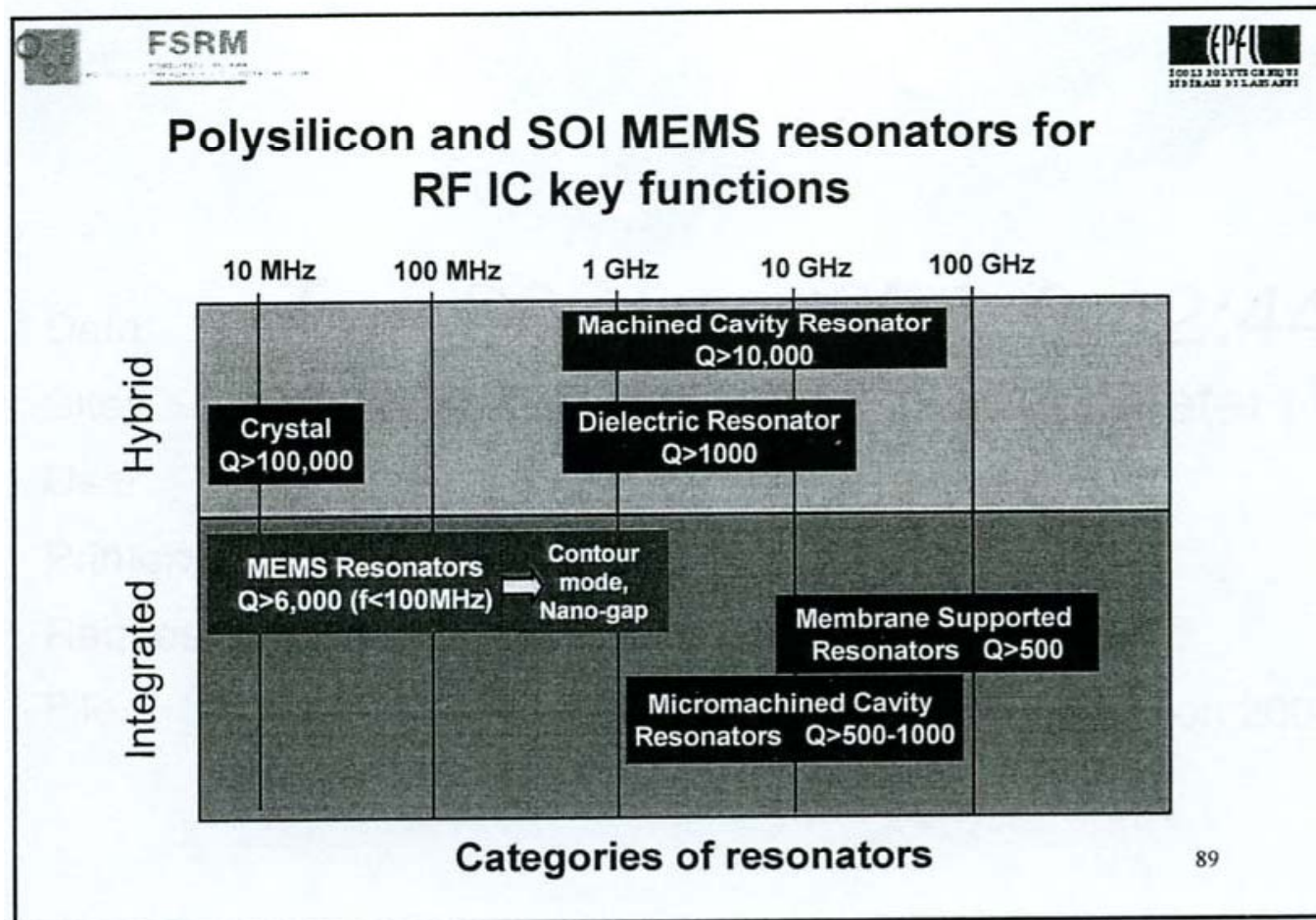

Ionescu, EPFL

→ We focus on real vibrating resonators!

# Typical properties

- Vibrating resonators can be **scaled** down to micrometer lengths
  - Analogy with IC-technology
  - Reduced dimensions give mass reduction and increased spring constant → **increased resonance frequency**
- Vibrating MEMS resonators can give **high Q-factor**
- MEMS resonators with high Q over a large bandwidth and integrated with electronics enable effective **miniaturization of complete systems!**

# MEMS resonators

- MEMS resonators can be used for basic circuit functions
  - Frequency reference: oscillator
    - Can be realized without external discrete passive components!
    - Relevant frequencies for MEMS resonators
      - 0.8 – 2.5 GHz for front-end wireless systems
      - 500 kHz → for IF frequency
  - Filtering
  - Mixing and filtering (“mixlers”, Nguyen)

# Vibrating MEMS resonators

- Classification (De Los Santos)
  - **One-port:** same electrode used for excitation and detection of beam vibration
  - **Two-port:** separate electrodes for excitation and detection of the vibrating beam structure

# Lateral and vertical movement

- Lateral movement
  - Parallel to substrate
  - Ex.: **Folded beam comb-structure**
- Vertical movement
  - Perpendicular to substrate
  - Ex.: **clamped-clamped beam (c-c beam)**
  - **“free-free beam” (f-f beam)**

# Working principles for basic resonator structures

- Resonator using **folded beam comb-structure**
  - Developed at UoC, Berkeley
  - One of the earliest resonator designs fabricated
- Comb-structures are in general used in many types of MEMS systems
  - For example used for **accelerometer, gyro**, variable **capacitance**

# Comb-resonator

- Fixed comb + movable, suspended comb
- Using folded springs, compact layout
- Total capacitance between combs can be varied
- Applied voltage (+ or -) generates electrostatic force between left anchor comb and "shuttle"-comb. Plate pulled left laterally controlled by drive voltage

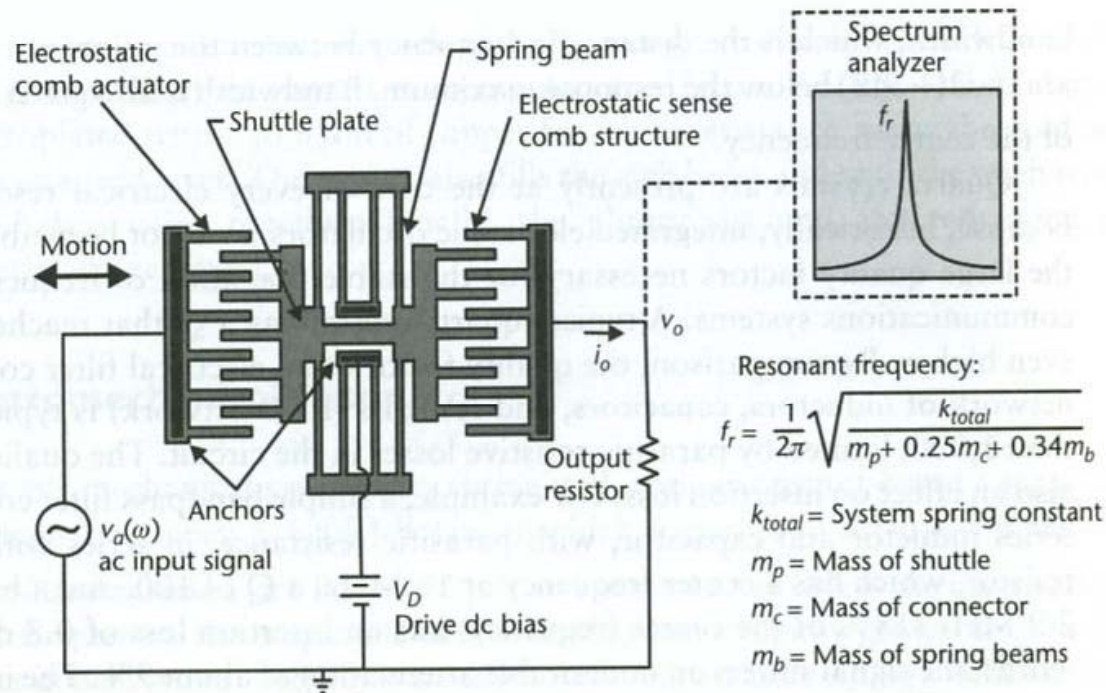

**Figure 7.9** Illustration of a micromachined folded-beam comb-drive resonator. The left comb drive actuates the device at a variable frequency  $\omega$ . The right capacitive-sense-comb structure measures the corresponding displacement by turning the varying capacitance into a current, which generates a voltage across the output resistor. There is a peak in displacement, current, and output voltage at the resonant frequency.

# Comb-resonator, spring constant

- Spring constant for simple c-c beam deflected to the side
  - $k_{\text{beam}} = 4 \cdot \frac{1}{4} \cdot E \cdot t \cdot (w/L)^3$ 
    - $E$  = Young's modulus,  $t$  = thickness,  $w$  = width,  $L$  = length
    - eg. 4 folded =  $4 \cdot \frac{1}{4}$  ( $\frac{1}{4}$  for each cantilever)
- In figure  $k_{\text{total}} = 2 \cdot k_{\text{beam}}$

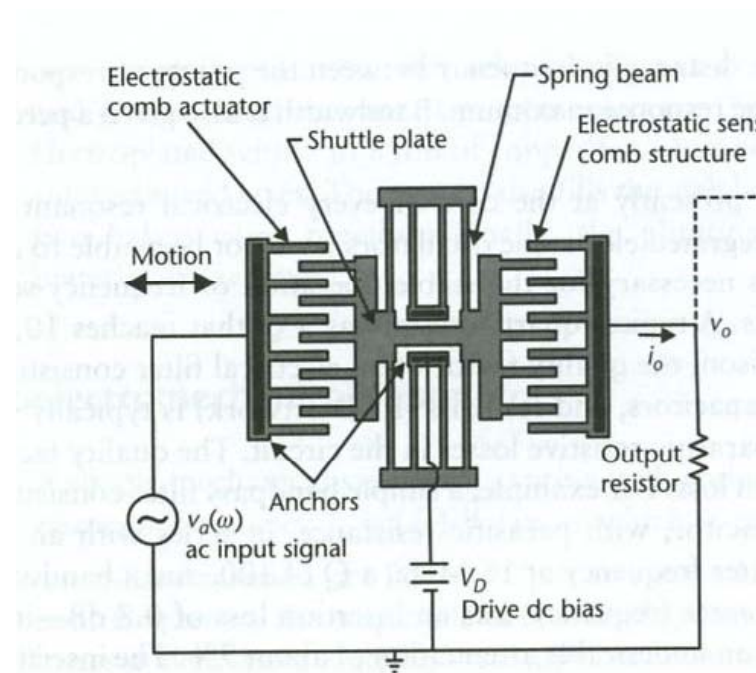



# Comb-resonator, mass

- m-contributions to resonance frequency
  - Spring moves less than shuttle mass
  - Beam mass is partly added to shuttle mass

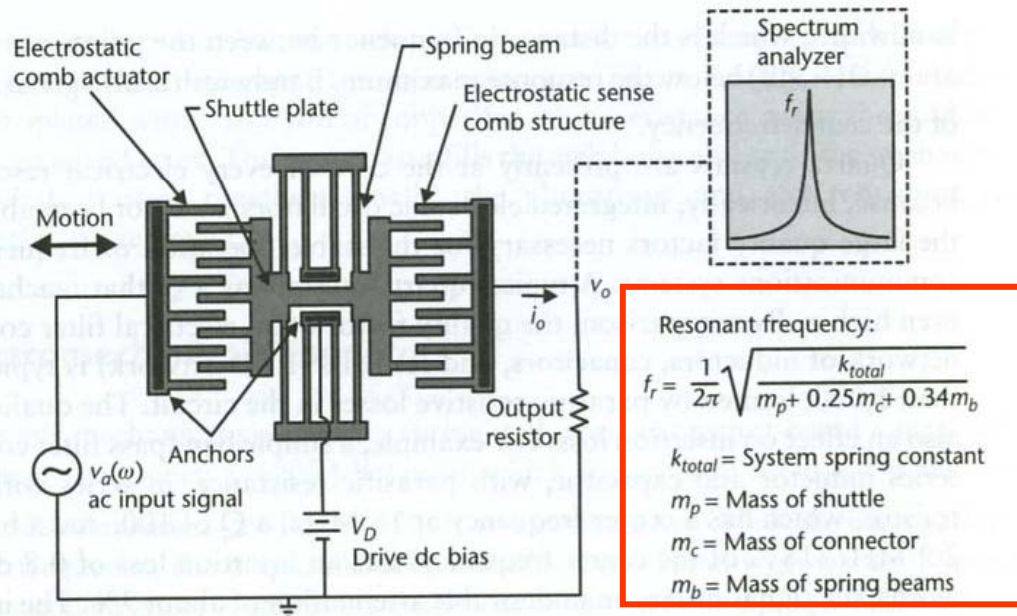

Figure 7.9 Illustration of a micromachined folded-beam comb-drive resonator. The left comb drive actuates the device at a variable frequency  $\omega$ . The right capacitive-sense-comb structure measures the corresponding displacement by turning the varying capacitance into a current, which generates a voltage across the output resistor. There is a peak in displacement, current, and output voltage at the resonant frequency.

# Comb-resonator, summary

- Summary of modeling:
- Force:  $F_e = \frac{1}{2} \frac{dC}{dx} V^2$  (force is always attractive)
  - Input signal  $V_a \cos(\omega t)$
  - $F_e \sim V_a^2 \cdot \frac{1}{2} [1 + \cos(2\omega t)]$
  - Driving force is 2x input frequency + DC: NOT DESIRABLE
- Add DC bias,  $V_d$ 
  - $F_e \sim V_d^2 + 2 V_d \cdot V_a \cos \omega t$  + negligible term ( $2\omega t$ )
  - Linear AC force-component  $\sim V_d \cdot V_a$ , has same frequency as  $V_a$ :  $\omega$ . Is emphasized!
- C increases when finger-overlap increases
  - $\epsilon \cdot A/d$  (A = comb thickness \* overlap-length)
- $dC/dx = \text{constant}$  for a given design (linear change, C is proportional to length variation)

# Comb-resonator, output current

- A time varying capacitance at the output comb is established
  - Calculating of output current when  $V_d$  is constant and  $C$  is varying
    - $I_0 = d/dt (Q) = d/dt (C \cdot V) = V_d \cdot dC/dt = V_d \cdot dC/dx \cdot dx/dt$
    - $I_0 = V_d \cdot dC/dx \cdot \omega \cdot x_{\max}$
    - $I_0$  plotted versus frequency, shows a BP -characteristic
  - **Detailed modeling in next lecture!**

# Feedback → oscillator

- Structure can have **2 output ports**
  - Feedback is isolated from any variation of output load
  - Ex. 16.5 kHz oscillator,  $Q = 50.000$  in vacuum

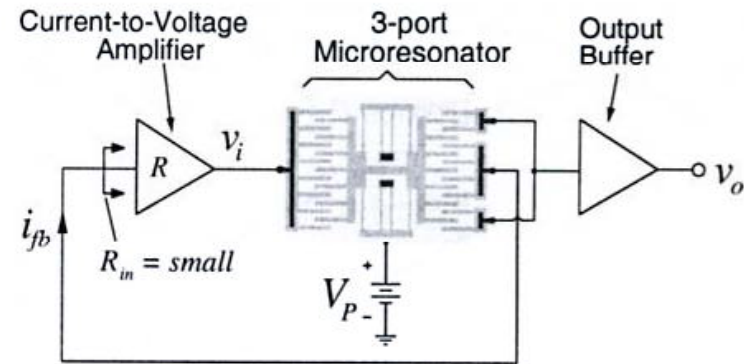

Fig. 8: System level schematic for the  $\mu$ resonator oscillator.

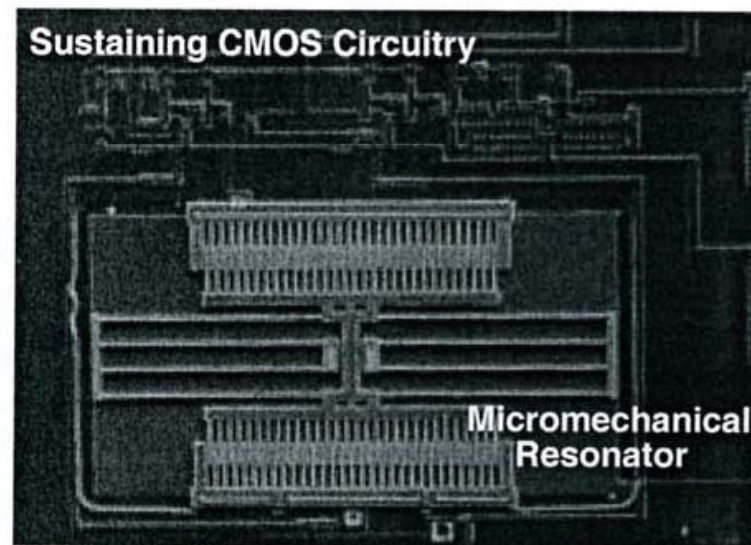

Fig. 9: SEM of a fully monolithic high- $Q$  CMOS micromechanical resonator oscillator.

# Micro resonator oscillator

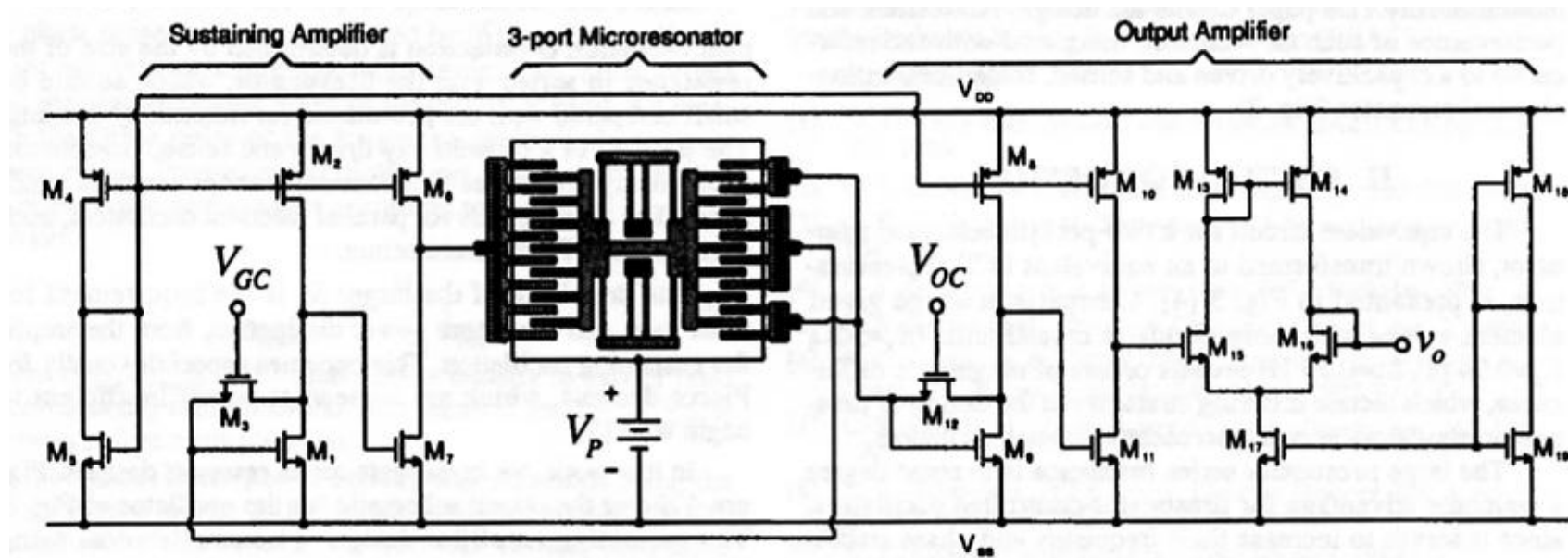

Fig. 4: Circuit schematic for the  $\mu$ resonator oscillator.

# Design parameters for comb-structure

- To achieve high resonance frequency
  - Total **spring constant** should increase
  - Or **dynamic mass** should decrease
    - Difficult, since a given number of fingers are needed for electrostatic actuation
  - $k$  and  $m$  depend on material choice, layout, dimensions
- **$E/\rho$**  expresses the spring constant relative to mass
  - Frequency can increase by using a material with larger  $E/\rho$  ratio than Si
    - Aluminium and Titanium has  $E/\rho$  lower than for Si
    - Si carbide, poly diamond has  $E/\rho$  higher than for Si (poly diamond is a relevant research topic)
- **Alternatively: use of other structures →**

# Beam-resonator

- Obtain **higher resonance frequency** than comb structure
  - Mass must be reduced more → **beam resonator**
- Studied in detail at UoMichigan
  - Commercialized by Discera, Inc., Ann Arbor, Michigan
    - Produces reference frequency oscillators substituting quartz crystals in mobile phones
- **Clamped-clamped beam**

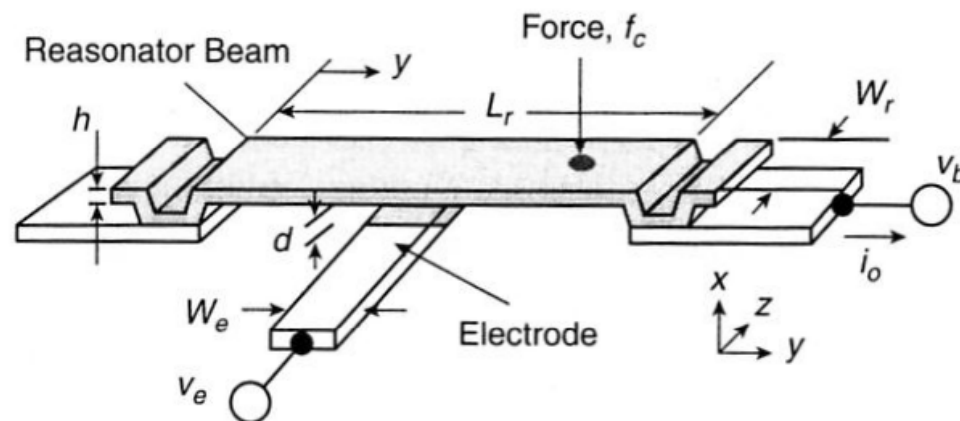

# Beam-resonator, contd.

- Electrode under beam, electrostatic actuation
- Plate attracted for both positive and negative wave. Actuated with double frequency
  - → Need a polarization voltage,  $V_d$ , between beam and actuation electrode
  - As for "lateral shuttle": When  $V_d$  is combined with ac-signal, then beam oscillates with same frequency as ac signal
  - At resonance the amplitude is maximum

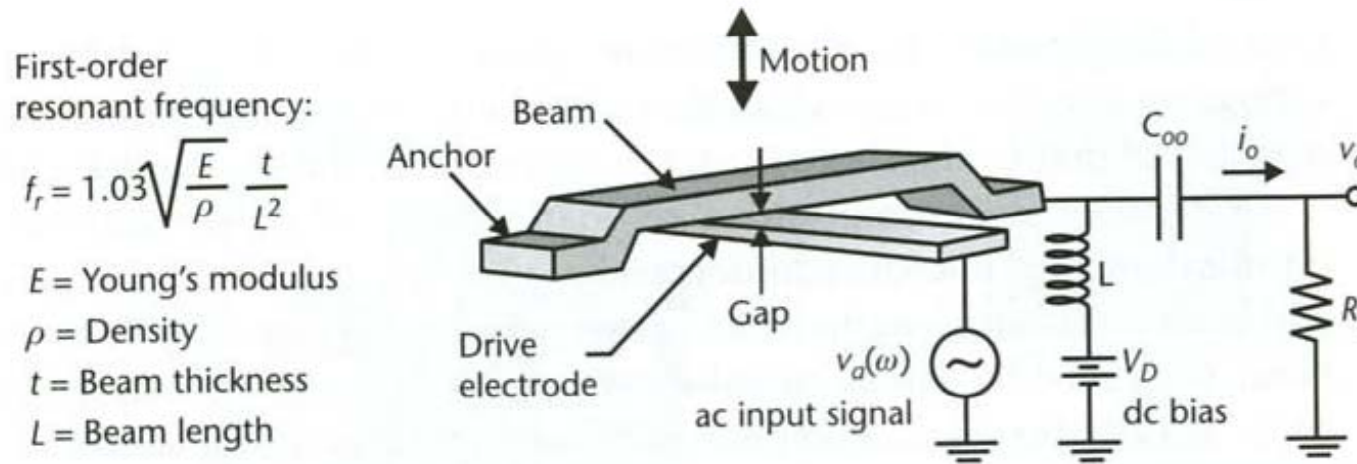
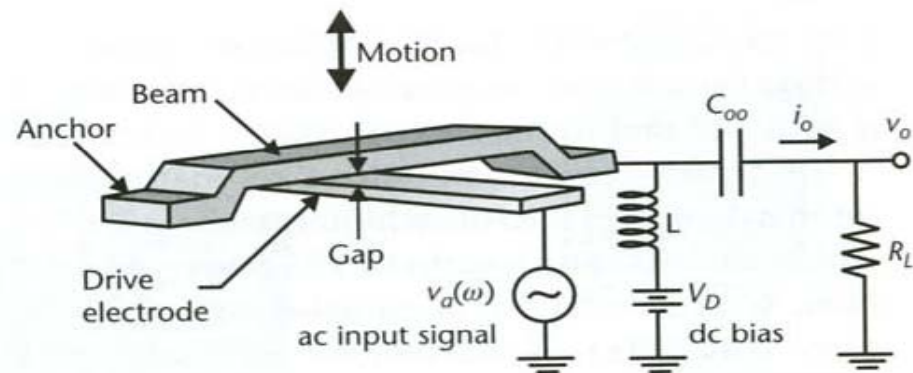

**Figure 7.10** Illustration of a beam resonator and a typical circuit to measure the signal. The beam is clamped on both ends by anchors to the substrate. The capacitance between the resonant beam and the drive electrode varies with the deflection.



# Beam-resonator, contd.

- Detection of output signal
  - Mechanical vibrations establish a time varying capacitance with constant voltage,  $V_p$ , on the beam
  - $Q = V_p * C$  will then vary
  - A displacement current is generated
    - $i_0 \sim dC/dx * dx/dt$
    - $I_0$  versus frequency shows a BP -behaviour
      - $Q \sim 10,000$  in vacuum



# Benefits of beam-resonators

- Simple structure
- Smaller dimensions, smaller mass → higher resonance frequency
- Can have many frequency references on one single chip
- More linear frequency variation with respect to temp over a larger interval
- Integration with electronics possible → reduced cost

# c-c beam

- c-c beam can be used as a reference-oscillator or HF/VHF filter/mixer
- An example: poly beam [Nguyen et al]
  - $l = 41 \mu\text{m}$ ,  $w = 8 \mu\text{m}$ ,  $t = 1.9 \mu\text{m}$
  - $g = 130 \text{ nm}$ ,  $V_d = 10 \text{ V}$ ,  $v_a = 3 \text{ mV}$
  - $f_r = 8.5 \text{ MHz}$
  - Deflection amplitude = 4.9 nm at beam centre
  - $Q = 8,000$  at 9 Pa
  - $Q < 1,000$  at 1 atm
    - **Reduction of Q at 1 atm!**

# Loss in c-c-beam

- Reasons for Q degradation for MEMS resonators
  - Energy loss to substrate via anchors
  - Air/gas damping
  - Intrinsic friction
  - Small dimensions (low stored energy compared with energy loss)
- To obtain higher resonance frequency: stiffness of a given resonator beam has to be increased
  - More energy pr cycle leaks to substrate via anchors
  - → Q-factor decreases
- c-c-beam is not the best structure for high frequencies!
  - Eks.  $Q = 8,000$  at 10 MHz,  $Q = 300$  at 70 MHz
- → "free-free beam" can be used to reduce substrate loss via anchors!

# ”free-free-beam”

- f-f-beam is suspended with 4 support-beams in width-direction
  - **Torsion-springs**
  - Suspension points at **nodes** for beam ”flexural mode”
- Support-dimension is a **quarter-wavelength** of f-f-beam resonance frequency
  - The impedance seen at the nodes is **infinite** preventing energy propagating along the beam to the anchor
  - Beam is free to vibrate as if it was not anchored
  - Beneficial for reducing energy loss via anchors to substrate

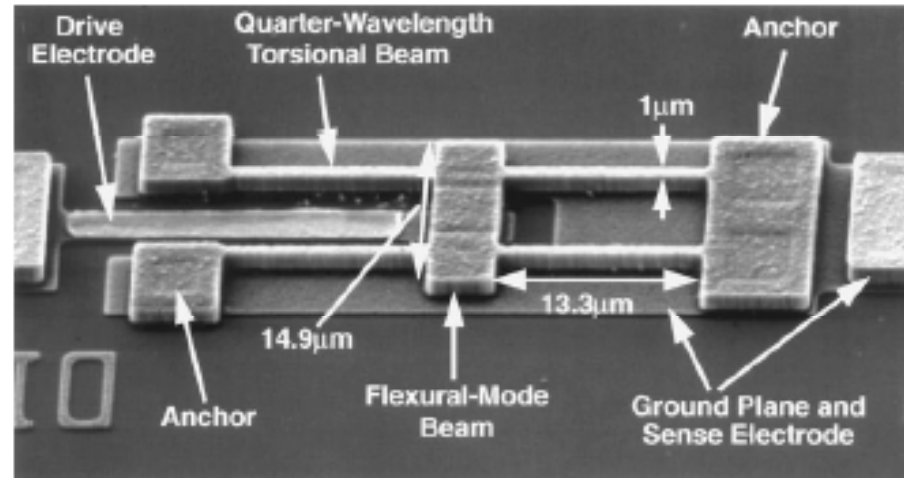
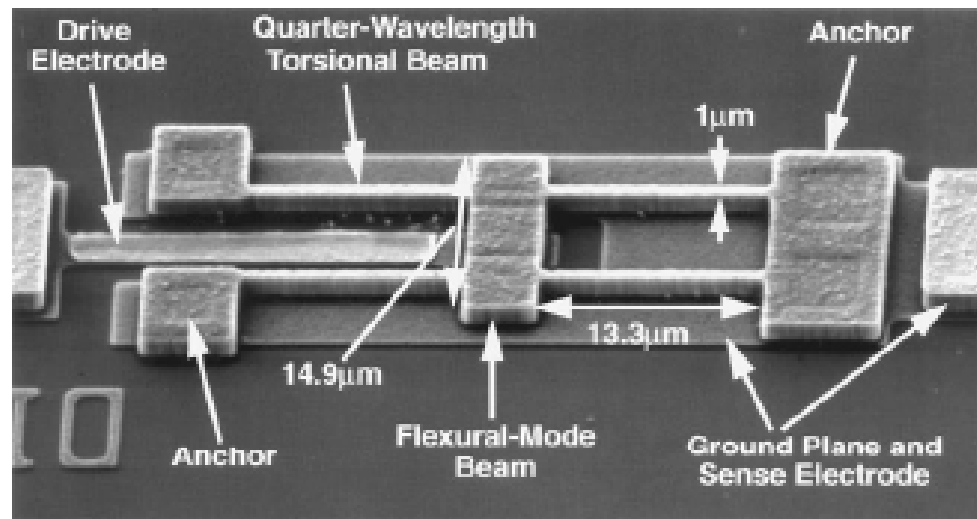

Fig. 29. SEM of free-free beam virtually levitated micromechanical resonator with relevant dimensions for  $f_o = 71$  MHz.

Nguyen, 1999

# free-free-beam

- Higher Q can be obtained with f-f-beams
  - Ex.  $Q = 20,000$  at 10 – 200 MHz
  - Used as reference oscillators, HF/VHF-filters/mixers



→ Other structures, **vibrating discs**, in a future lecture