

# INF5490 RF MEMS

## **LN09: RF MEMS resonators III**

Spring 2011, Oddvar Søråsen  
Jan Erik Ramstad  
Department of Informatics, UoO

# Today's lecture

- Vertical vibrating resonators
  - clamped-clamped beam (c-c beam)
    - Working principle
    - → **Detailed modeling**
  - free-free beam (f-f beam)
- Ex.: other resonator types
  - Tuning fork
  - Beam with lateral displacement
  - Disk resonators

# Beam resonator

- How to obtain a higher resonance frequency than what is possible with the comb-structure?
  - Mass should be reduced more -> **beam resonator**
- Beam resonator benefits
  - Smaller dimensions
  - Higher resonance frequency
  - Simple
  - Many frequency references on a single chip
  - Frequency variation versus temperature is more linear over a broader temperature range
  - Integration with electronics possible → lower cost

# Beam resonator

First-order resonant frequency:

$$f_r = 1.03 \sqrt{\frac{E}{\rho}} \frac{t}{L^2}$$

$E$  = Young's modulus

$\rho$  = Density

$t$  = Beam thickness

$L$  = Beam length

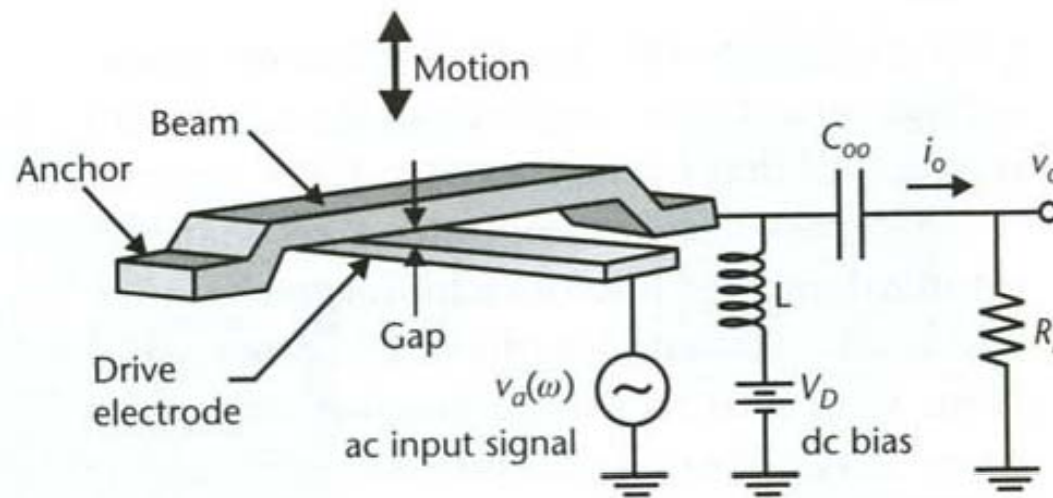
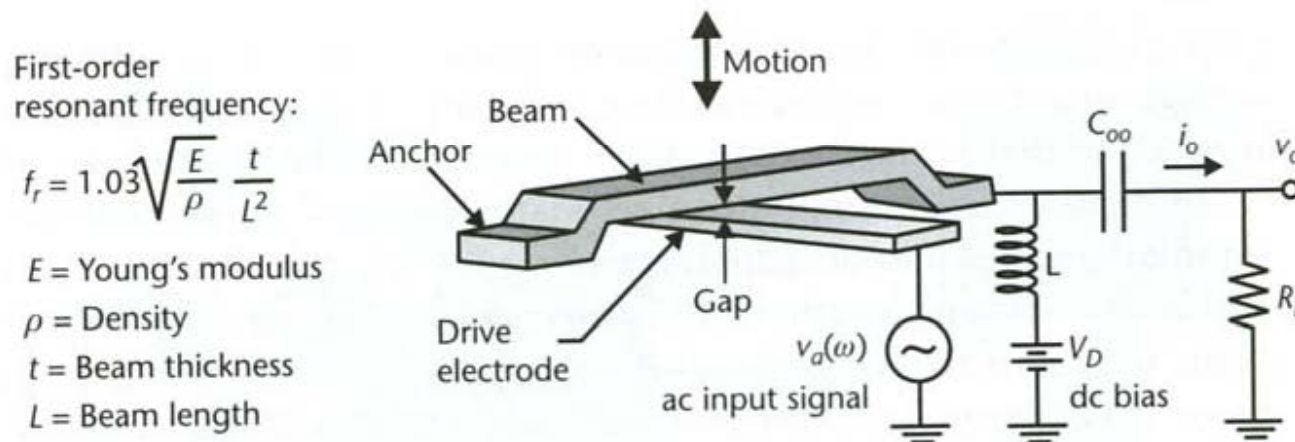

**Figure 7.10** Illustration of a beam resonator and a typical circuit to measure the signal. The beam is clamped on both ends by anchors to the substrate. The capacitance between the resonant beam and the drive electrode varies with the deflection.

**”One-port”-implementation**

# Output circuit

- Resonator is a time varying capacitance  $C(\omega)$
- Simple electrical output circuit
  - $L$  = shunt RF blocking inductor: **Open circuited** at high frequencies
  - $C_{\infty}$  = series DC blocking capacitance: **Short circuited** at high frequencies
  - When  $V_d$  is a large DC-voltage bias, the dominating output current at frequency  $\omega$  is given by:  $i_o = V_d * dC/dt$
  - At high frequencies the current  $i_o$  is flowing through  $R_L \rightarrow$  giving  $V_o$ 
    - $R_L$  may be the input impedance in the measurement equipment. Can be replaced by a transimpedance amplifier



**Figure 7.10** Illustration of a beam resonator and a typical circuit to measure the signal. The beam is clamped on both ends by anchors to the substrate. The capacitance between the resonant beam and the drive electrode varies with the deflection.

# Mechanical resonance frequency

$$f_o = \frac{1}{2\pi} \sqrt{\frac{k_r}{m_r}} = 1.03\kappa \sqrt{\frac{Eh}{\rho L_r^2}} [1 - g(V_P)]^{1/2}, \quad (12.2)$$

- Parameters
  - E = Young's modulus
  - $\rho$  = density of material
  - h = beam thickness
  - $L_r$  = beam length
  - g models the effect of an **electrical spring constant  $k_e$** 
    - Is present when a voltage is applied between the electrodes
    - Subtracted from the mechanical spring constant,  $k_m$  ("beam-softening")
  - $\kappa$  = scaling factor (influenced by the surface topography, typical 0.9)
  - $V_p$  = DC bias on conducting beam
  - $k_r$  = effective resonator spring constant
  - $m_r$  = effective mass
  - 1.03 = 1<sup>st</sup> resonating mode
- **NB! E and  $\rho$  included in the expression + spring stiffness compensation term**

# ”Beam-softening”

- DC-voltage,  $V_d$ , will give a downward-directed electrostatic force
- This force opposes the mechanical restoring force of the beam
- The result is a lower **effective** spring constant

– → **Electrical (fine) tuning of resonance frequency can be done!**

– Resonance frequency decreases by a given factor  $[1-g(V_P)]^{1/2}$

$$= \sqrt{1 - C \cdot V_P^2 / (k \cdot g^2)}$$

To be shown

The resonance frequency can be tuned by  $V_p$

The electrically tunable spring constant,  $k_e$ , is subtracted from the mechanical one

The electrostatic beam-softening will change the spring stiffness  
The resulting spring constant will be decreased:

$$k_r = k_m - k_e, \text{ mechanical minus electrical}$$

The resonance frequency

$$f_0 = \frac{1}{2\pi} \sqrt{\frac{k_m - k_e}{m_r}} = \frac{1}{2\pi} \sqrt{\frac{k_m}{m_r} \left(1 - \frac{k_e / m_r}{k_m / m_r}\right)} = \frac{1}{2\pi} \sqrt{\frac{k_m}{m_r} \left(1 - \left\langle \frac{k_e}{k_m} \right\rangle\right)^{1/2}}$$

$$f_0 = 1.03 \chi \sqrt{\frac{E}{\rho}} \cdot \frac{h}{L^2} \left(1 - \left\langle \frac{k_e}{k_m} \right\rangle\right)^{1/2}$$

 The relation is changed along the y-direction and has to be "summed" in an integral



# Typical frequencies

**TABLE 12.1.  $\mu$ Mechanical Resonator Frequency Design<sup>a</sup>**

Frequency (MHz)	Material	Mode	$h_r$ ( $\mu\text{m}$ )	$W_r$ ( $\mu\text{m}$ )	$L_r$ ( $\mu\text{m}$ )
70	Silicon	1	2	8	14.54
110	Silicon	1	2	8	11.26
250	Silicon	1	2	4	6.74
870	Silicon	2	2	4	4.38
870	Diamond	2	2	4	8.88
1800	Silicon	3	1	4	3.09
1800	Diamond	3	1	4	6.16

<sup>a</sup>Determined for free-free beams using Timoshenko methods that include the effects of finite  $h$  and  $W_r$  [11].

# Detailed modeling

- **c-c beam** modeled as in the book
  - *T. Itoh et al: RF Technologies for Low Power Wireless Communications”, chap. 12: ”Transceiver Front-End Architectures Using Vibrating Micromechanical Signal Processors”, by Clark T.-C. Nguyen*
  - *(+ summary from various publications by Nguyen)*

# Clamped-clamped beam

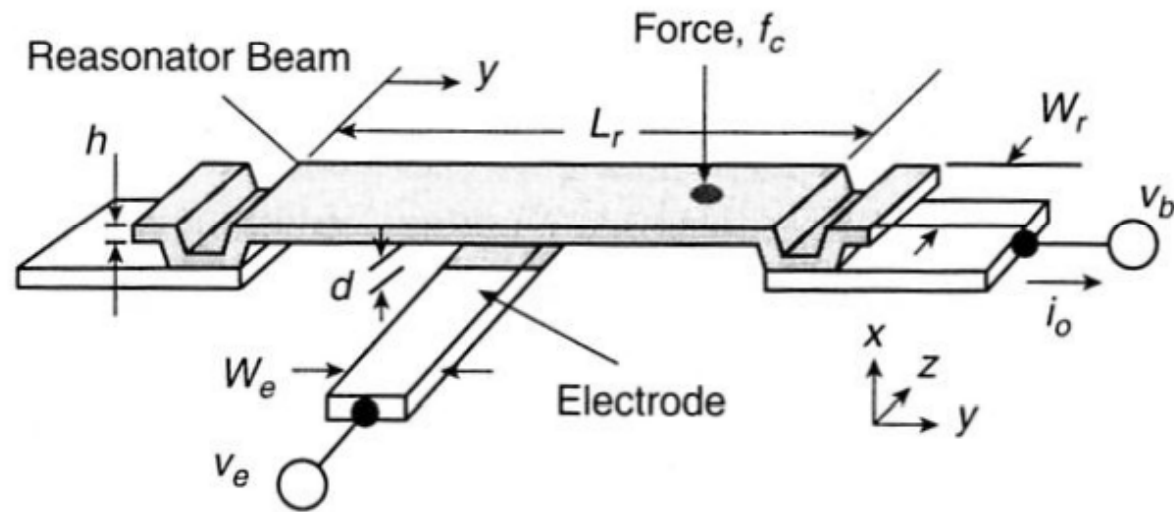

**Figure 12.4.** Perspective-view schematic of a clamped-clamped beam  $\mu$ mechanical resonator in a general bias and excitation configuration.

# Calculating electrical excitation

- Two bias voltages are applied
- A) First calculate potential energy
- B) Calculate force  $\rightarrow$

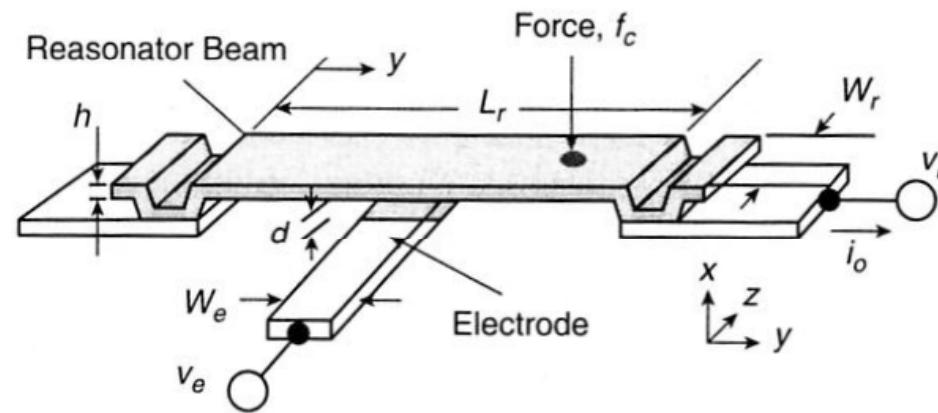

**Figure 12.4.** Perspective-view schematic of a clamped-clamped beam  $\mu$ mechanical resonator in a general bias and excitation configuration.

## A. Electrical excitation

$v_e$  = input on electrode

$v_b$  = input on beam

$v_e - v_b$  = effective voltage

$$U = \frac{1}{2}CV^2 = \frac{1}{2}C(v_e - v_b)^2 = \text{potential energy}$$

$$F_d = \frac{\partial U}{\partial x} = \frac{1}{2}(v_e - v_b)^2 \frac{\partial C}{\partial x}$$
$$= \frac{1}{2}(v_b^2 - 2v_b v_e + v_e^2) \frac{\partial C}{\partial x}$$

**B.** Force is change of potential energy vs.  $x$

$$C = \frac{\epsilon_0 A}{d_0} = \epsilon_0 \frac{W_e W_r}{d_0}$$

Without static beam bending

$W_e$  = electrode width,  $W_r$  = beam width

$d_0$  = electrode – resonator gap (static, non - resonance)

$\epsilon_0$  = permittivity in vacuum

# Procedure, contd.

- C) Apply DC bias,  $V_p$
- D) Calculate the force
- E) Discussion of different contributions
  - Off-resonance DC-force
  - Force with the same frequency as input voltage
  - Double frequency term

**C.** A DC voltage is applied to the beam

$$v_b = V_P, \quad v_e = v_i = V_i \cos \omega_i t$$

**D.**

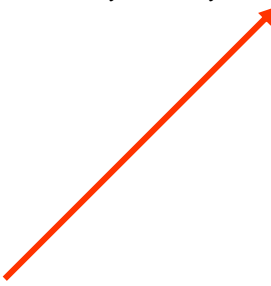
$$F_d = \frac{1}{2} (V_P^2 - 2V_P V_i \cos \omega_i t + V_i^2 \cos^2 \omega_i t) \frac{\partial C}{\partial x}$$

Observe that:

$$\cos^2 \omega_i t = \frac{1}{2} (1 + \cos 2\omega_i t)$$

$$V_i^2 \cos^2 \omega_i t = \frac{V_i^2}{2} (1 + \cos 2\omega_i t)$$

Then

$$F_d = \left( \frac{1}{2} V_P^2 - V_P V_i \cos \omega_i t + \frac{1}{2} \frac{V_i^2}{2} + \frac{1}{2} \frac{V_i^2}{2} \cos 2\omega_i t \right) \frac{\partial C}{\partial x}$$

**E.**

$$F_d = \underbrace{\frac{\partial C}{\partial x} \left( \frac{V_P^2}{2} + \frac{V_i^2}{4} \right)}_{\text{Off-resonance DC force}} - \underbrace{V_P \frac{\partial C}{\partial x} V_i \cos \omega_i t + \frac{\partial C}{\partial x} \frac{V_i^2}{4} \cos 2\omega_i t}_{\text{Force driven by the input frequency, amplified by } V_P}$$

Off-resonance DC force  
Static bending of beam

Force driven by the input frequency,  
amplified by  $V_P$

$$\frac{\partial C}{\partial x} \frac{V_i^2}{4} \cos 2\omega_i t$$

This term can drive the beam into vibrations at

$$2\omega_i = \omega_0, \text{ and } \omega_i = \frac{\omega_0}{2}$$

The term can usually be **neglected**



# Topology

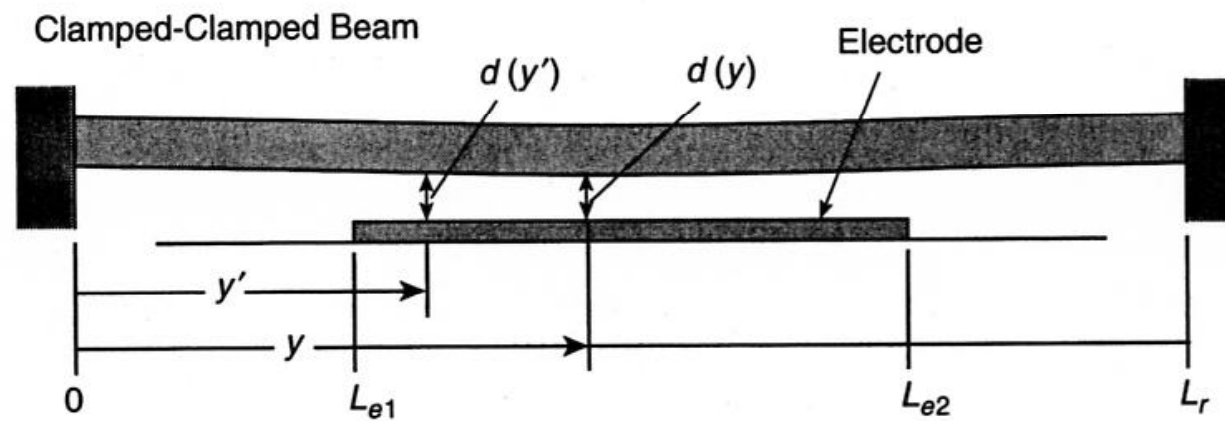

**Figure 12.9.** Resonator cross-sectional schematic for frequency-pulling and impedance analysis.

Gap and force vary over the electrode width

# Procedure, contd.

- → The main contribution to the force is proportional to  $\cos$ 
  - Drives beam into resonance
- **F)** Force gives displacement (x-variation)
  - The local spring constant varies over the width of the drive-electrode
  - Local displacement depends on the y position
- **G)** Derivation of an expression for the displacement,  $x(y)$ , versus the spring constant at position y

The main contribution to the force:  $-V_P \frac{\partial C}{\partial x} V_i \cos \omega_i t$

At resonance the force will be:

$$F_d = -V_P \frac{\partial C}{\partial x} v_i(\omega_0)$$

The force will give a **varying displacement**, and the distance between the beam and electrode is dependent on y-position

Generally:  $F = k \cdot x$ , static!

$k(y) = k_{\text{reff}}(y)$  = effective beam stiffness in y

Dynamic performance of a mechanical system:

**F.**

$$H(s) = \frac{x}{F} = \frac{\text{displacement}}{\text{force}} = \frac{1/m}{s^2 + \frac{b}{m}s + \frac{k}{m}}$$

$$H'(s) = \frac{kx}{F} = \frac{k/m}{s^2 + \frac{b}{m}s + \frac{k}{m}} = \frac{\omega_0^2}{s^2 + \frac{\omega_0}{Q}s + \omega_0^2}$$

$$H'(j\omega_0) = \frac{\omega_0^2}{-\omega_0^2 + j\frac{\omega_0}{Q}\omega_0 + \omega_0^2} = \frac{Q}{j} \quad \leftarrow \text{At resonance}$$

$$kx = F \cdot \frac{Q}{j}, \text{ at resonance} \quad (\text{generally})$$

**G.** In our case:

$$x(y) = + \frac{Q}{j} \frac{F_d}{k_{\text{reff}}(y)} = - \frac{Q}{jk_{\text{reff}}} \cdot V_P \cdot \frac{\partial C}{\partial x} \cdot v_i$$

Force and displacement in opposite directions

# Procedure, contd.

- When the beam moves, a time varying capacitance is established between the electrode and resonator beam
- H) This gives an **output current** that is "DC-biased" via  $V_p$ 
  - $dC/dx$  is a non-linear term
  - $dx/dt$  is speed

When the beam moves, a time dependent capacitance between the electrode and resonator will be created, giving an output current:

H. 
$$i_o = -V_P \frac{\partial C}{\partial x} \frac{\partial x}{\partial t} = \dot{Q}_o, \text{ where } Q_o = V_P C$$

$$Q_o = V_P \cdot C$$

$$\dot{Q}_o = i_o =$$

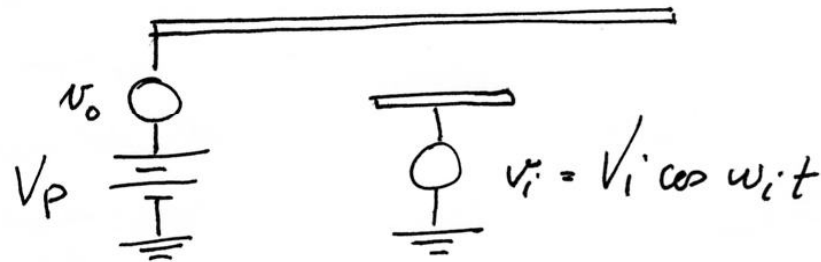

# Frequency response

- Typical parameters, Q, vacuum
  - Bandpass filter characteristics,  $Q \sim 10,000$
  - Suitable for low loss reference oscillators and filters
- $Q \sim$  a few hundreds at 1 AMP

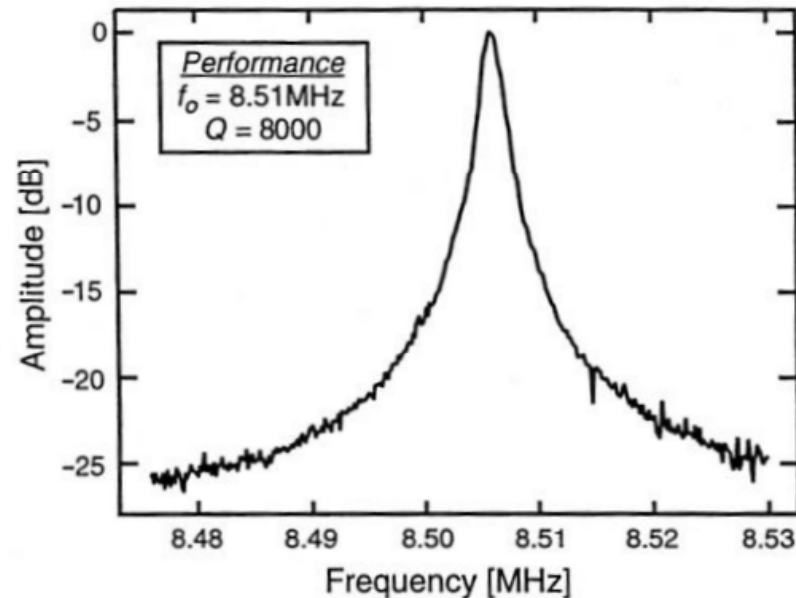

**Figure 12.7.** Frequency characteristic for an 8.5 MHz clamped-clamped beam polysilicon  $\mu$ mechanical resonator measured under 70 mtorr vacuum using a dc-bias voltage  $V_p = 10$  V, a drive voltage of  $v_i = 3$  mV, and a transresistance amplifier with a gain of  $33\text{ K}\Omega$  to yield an output voltage  $v_o$ . Amplitude =  $v_o/v_i$ . (From reference [18])

# Procedure, contd.

- Transform to mechanical equivalent circuit:
  - "mass-spring-damper"-circuits
  - NB! Still operating in the mechanical domain
- Beam described using "lumped elements"
- Element values vary and depend on the position of beam, - dependent on  $y$ .

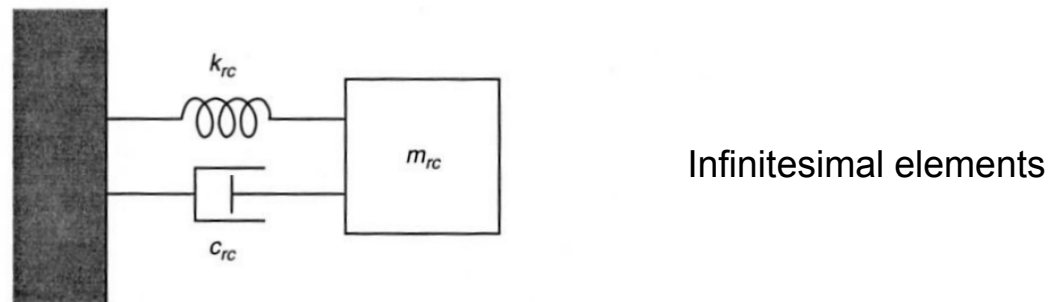

**Figure 12.8.** Lumped-parameter mechanical equivalent circuit for the micromechanical resonator of Figure 12.4.



# First, look at the **mass** contribution

- I. Calculation of "equivalent mass" as function of  $y$   
*From R. A. Johnson: "Mechanical Filters in Electronics", Wiley, 1983*

Simplified derivation of deflection equation

Calculate the form of the "fundamental mode"

**Each point,  $y$ , has a specific effective mass, a specific velocity and spring constant**

Lowest "mass" in the middle, where the speed is maximum

$$m_r(y) = \frac{KE_{tot}}{\frac{1}{2}[v(y)]^2}$$

The equivalent mass at position  $y$

$KE_{tot}$  = peak kinetic energy of the system

$v(y)$  = velocity at location  $y$

## Flexural mode resonator: beam

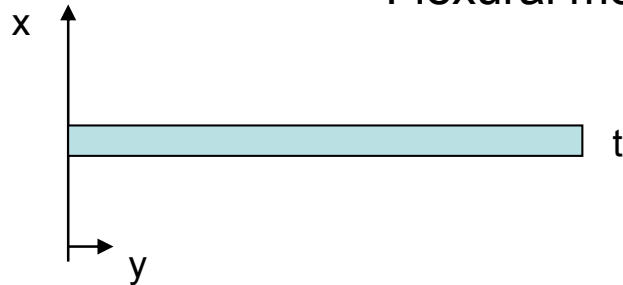

$w$  = width,  $u$  = displacement in  $x$  – direction

$E$  = elastic modulus,  $\rho$  = density

$$I = \frac{wt^3}{12} = \text{moment of inertia}$$

The beam equation

$$\frac{\partial^2 u}{\partial t^2} = \frac{EI}{\rho A} \cdot \frac{\partial^4 u}{\partial y^4}, \text{ where } u = u_1 e^{j\omega t}$$

$$\Rightarrow \frac{\partial^4 u}{\partial y^4} = \left(\omega^2 \frac{\rho A}{EI}\right) u$$

← Principally the same equation for c-c beam!

Trial solution :

$$u(y) = A \cosh ky + B \sinh ky + C \cos ky + D \sin ky$$

$A, B, C, D$  can be found from initial conditions

Mode shape for fundamental frequency, c - c beam :

$$u(y) = \xi(\cos ky - \cosh ky) + (\sin ky - \sinh ky)$$

here:  $k$  is the "wave number"

(From "Johnson")

$X_{\text{mode}}$  = shape of the fundamental mode  
= displacement as a function of  $y$

$$X_{\text{mode}}(y) = \xi(\cos \beta y - \cosh \beta y) + (\sin \beta y - \sinh \beta y)$$

$$\beta = 4.730 / L_r, \text{ "wave number"}$$

$$\xi = -1.01781$$

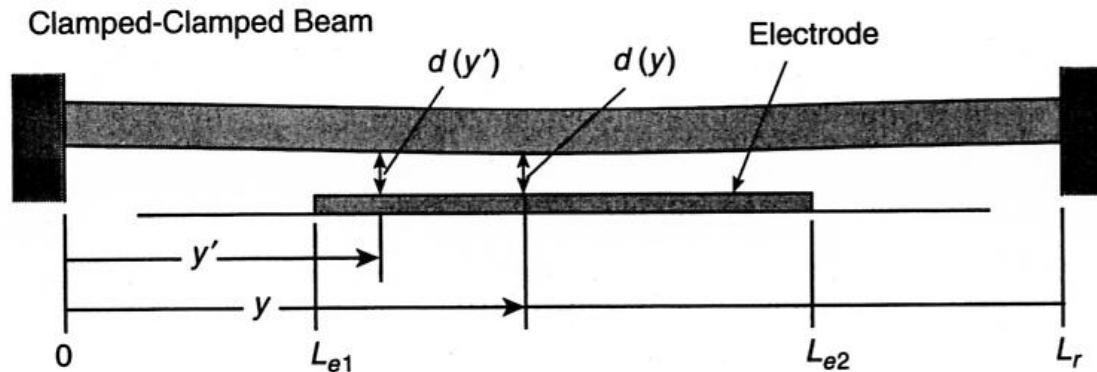

**Figure 12.9.** Resonator cross-sectional schematic for frequency-pulling and impedance analysis.

Velocity in y - direction (along the beam)

$$v(y) = \dot{u}(y) = \frac{\partial}{\partial t}(u_1 e^{j\omega t}) = j\omega \cdot u(y)$$

Equivalent mass :

$$M_{eq}(y) = \frac{KE_{tot}}{\frac{1}{2}v^2(y)} = \frac{\frac{1}{2}\rho A \int_0^l v^2(y') dy'}{\frac{1}{2}v^2(y)}$$

$$M_{eq}(y) = \frac{\frac{1}{2}\rho A(-\omega^2) \int_0^l u^2(y') dy'}{\frac{1}{2}(-\omega^2)u^2(y)} = \frac{\rho \omega t \int_0^l [X_{mode}(y')]^2 dy'}{[X_{mode}(y)]^2}$$

Xmode is the **"shape"** of the fundamental mode  
= displacement as a function of y

# Procedure, contd.

- **J)** After calculation of the equivalent mass as function of (y), the equivalent spring stiffness  $k_r(y)$  and damping factor  $c_r(y)$  can be calculated
  - $k_r$  = "equivalent", eg. influenced both by **mechanical** and **electrical** effects

Resonance frequency

$$f_0 = \frac{1}{2\pi} \sqrt{\frac{k_r}{m_r}}, \quad \omega_0^2 = \frac{k_r}{m_r}$$

**J.**

Equivalent spring stiffness

$k_r(y) = \omega_0^2 \cdot m_r(y)$ , where  $m_r(y)$  is the equivalent mass

The damping factor  $c_r(y)$ :

$$s^2 + \frac{b}{m}s + \frac{k}{m} = s^2 + \frac{\omega_0}{Q}s + \omega_0^2$$

$$c = b!$$

$$c = m \frac{\omega_0}{Q} = \frac{m \sqrt{k/m}}{Q} = \frac{\sqrt{km}}{Q}$$

By just looking at the **mechanical contribution**:

A certain frequency,  $\omega_{nom}$ , and a corresponding Q-factor,  $Q_{nom}$  are obtained:

The mechanical spring constant:  $k_m(y)$

gives the nominal values:  $\omega_{nom}$ ,  $Q_{nom}$

→ The damping is only dependent on the mechanical factors:

$$c_r(y) = b = \frac{\sqrt{k_m(y) \cdot m_r(y)}}{Q_{nom}}, \text{ where } k_m(y) = \omega_{nom}^2 \cdot m_r(y) \quad \mathbf{K.}$$

$$c_r(y) = \frac{\omega_{nom} \cdot m_r(y)}{Q_{nom}} = \frac{k_m(y)}{\omega_{nom} Q_{nom}}$$

$Q_{nom}$  is the Q-factor of the resonator without the effect of the applied voltage

$k_m(y)$  is the mechanical stiffness without being influenced by the applied voltage and electrodes

# Tunable electrical spring stiffness

- Spring stiffness can be **tuned** by  $V_p$ 
  - Effective spring stiffness is influenced by the electrical spring stiffness
  - The result depends on ratio between  $k_e$  and  $k_m$
- **L)** Calculate how  $k_e$  depends on position  $y$

The resonance frequency can be tuned by  $V_p$

The electrically tunable spring constant,  $k_e$ , is subtracted from the mechanical one

The electrostatic beam-softening will change the spring stiffness  
The resulting spring constant will be decreased:

$$k_r = k_m - k_e, \text{ mechanical minus electrical}$$

The resonance frequency

$$f_0 = \frac{1}{2\pi} \sqrt{\frac{k_m - k_e}{m_r}} = \frac{1}{2\pi} \sqrt{\frac{k_m}{m_r} \left(1 - \frac{k_e / m_r}{k_m / m_r}\right)} = \frac{1}{2\pi} \sqrt{\frac{k_m}{m_r} \left(1 - \left\langle \frac{k_e}{k_m} \right\rangle\right)^{1/2}}$$

$$f_0 = 1.03 \chi \sqrt{\frac{E}{\rho}} \cdot \frac{h}{L^2} \left(1 - \left\langle \frac{k_e}{k_m} \right\rangle\right)^{1/2}$$

 The relation is changed along the y-direction and has to be "summed" in an integral



$k_e$  is dependent on the capacitance  $C(y')$  which is dependent on the gap  $d(y')$  caused by  $V_p$

← Different gap spacing

By equating the potential energy to the work :

$$U = \frac{1}{2} k_e \cdot d^2 = \frac{1}{2} C V_p^2 = \frac{1}{2} V_p^2 \frac{\epsilon_0 A}{d}$$

(integration of "the Hookes law-force" times distance for a parallel plate C)

$$k_e = V_p^2 \frac{C}{d^2} = V_p^2 \frac{\epsilon_0 A}{d^3}$$

- L. A contribution to the total spring stiffness from an element at the location  $y'$  and with a small electrode width  $dy'$

$$dk_e(y') = V_p^2 \frac{\epsilon_0 W_r dy'}{[d(y')]^3}$$

**The local spring stiffness is dependent on the local value of the gap!**

(d is the displacement from an equilibrium position where  $V_p = 0$ )

## The gap, $d(y)$ , has to be computed:

A force of  $F$  will give a displacement from the equilibrium position where  $V_p = 0$ :

$$F = \frac{1}{2} V_p^2 \frac{\epsilon_0 A}{d^2} = k \cdot \text{"displacement"} \quad (\text{at each point, } y)$$

$$d(y) = d_0 - \frac{1}{2} V_p^2 \epsilon_0 W_r \int_{L_{e1}}^{L_{e2}} \frac{1}{k_m(y') [d(y')]^2} \cdot \frac{X_{sh}(y)}{X_{sh}(y')} dy'$$

The equation must be solved iteratively

← The distributed DC force defined by the **static** bending shape (1.st mode)

When  $d(y)$  has been found, then  $dk_e(y')$  can be computed:

$$dk_e(y') = V_p^2 \frac{\epsilon_0 W_r dy'}{[d(y')]^3}$$

Then

$$\left\langle \frac{k_e}{k_m} \right\rangle = g(d, V_p) = \int_{L_{e1}}^{L_{e2}} \frac{dk_e(y')}{k_m(y')} dy'$$

## Simplification (De Los Santos):

Assume that the beam is flat over the electrode

Potential energy  $U_1 = \frac{1}{2} C V_P^2$

Work being done to move the beam a distance  $g$   
AGAINST the force due to the electrical  
beam stiffness  $k_e$   
(The spring stiffness is now considered to be  
CONSTANT in each point  $y'$ )

$$U_2 = \int_0^g k_e \cdot x \cdot dx = \frac{1}{2} k_e \cdot g^2$$

The energies can be set equal

$$\frac{1}{2} k_e \cdot g^2 = \frac{1}{2} C \cdot V_P^2$$

Simplified expression for the electrical  
beam stiffness

$$k_e = \frac{C \cdot V_P^2}{g^2}$$

## Simplified expression for frequency

$$\begin{aligned} f &= \frac{1}{2\pi} \sqrt{\frac{k_m - k_e}{m_r}} = \frac{1}{2\pi} \sqrt{\frac{k_m}{m_r} \left(1 - \frac{k_e}{k_m}\right)} \\ &= \frac{1}{2\pi} \sqrt{\frac{k_m}{m_r}} \cdot \sqrt{1 - \frac{k_e}{k_m}} = f_{nom} \cdot \sqrt{1 - \frac{C \cdot V_P^2}{k_m \cdot g^2}} \end{aligned}$$

Substitute for C:  $C = \varepsilon_0 \cdot \frac{A}{g}$

$$f = f_{nom} \cdot \sqrt{1 - \frac{\varepsilon_0 \cdot A \cdot V_P^2}{k_m \cdot g^3}}$$

This is equivalent to the previous calculations

$$k_e = \epsilon_0 \cdot \frac{A \cdot V_P^2}{g^3}$$

$$dk_e(y') = V_P^2 \cdot \frac{\epsilon_0 \cdot W_r \cdot dy'}{[d(y')]^3}$$

 Differential electrical spring stiffness in location  $y'$  and with an electrode width  $dy'$

# Beam-softening

- Resonance frequency decreases by

$$\sqrt{1 - C_0 \cdot V_P^2 / (k_m \cdot g^2)} = [1 - g(V_P)]^{1/2}$$

- **→ resonance frequency may be tuned electrically!**

$$f_o = \frac{1}{2\pi} \sqrt{\frac{k_r}{m_r}} = 1.03\kappa \sqrt{\frac{E h}{\rho L_r^2}} [1 - g(V_P)]^{1/2}, \quad (12.2)$$



# Coupling coefficient

- Look into the circuit from the left side
- Observe a transformed LCR-circuit with new element values given by (eq. 12.17)
  - Electromechanical coupling coefficient = "transformer turns ratio"
- Coupling coefficient is calculated in notes from UCLA
  - Discussed in relation to 2-port lateral comb-drive actuator (LN08)



## Small Signal Equivalent Circuit of Microresonators

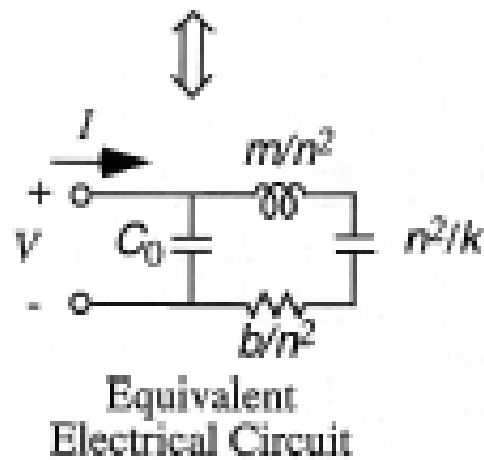
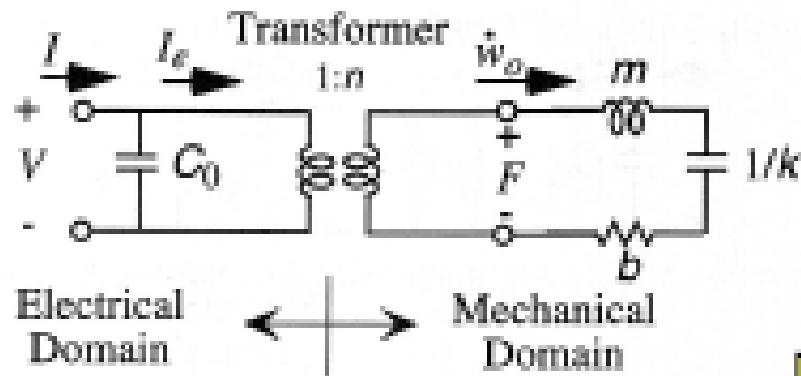

Unit of  $n^2/k$  is Farad

$$n = V_{dc} \frac{\partial C}{\partial x}$$

## Two-Port Equivalent Circuit ( $v_2 = 0$ )

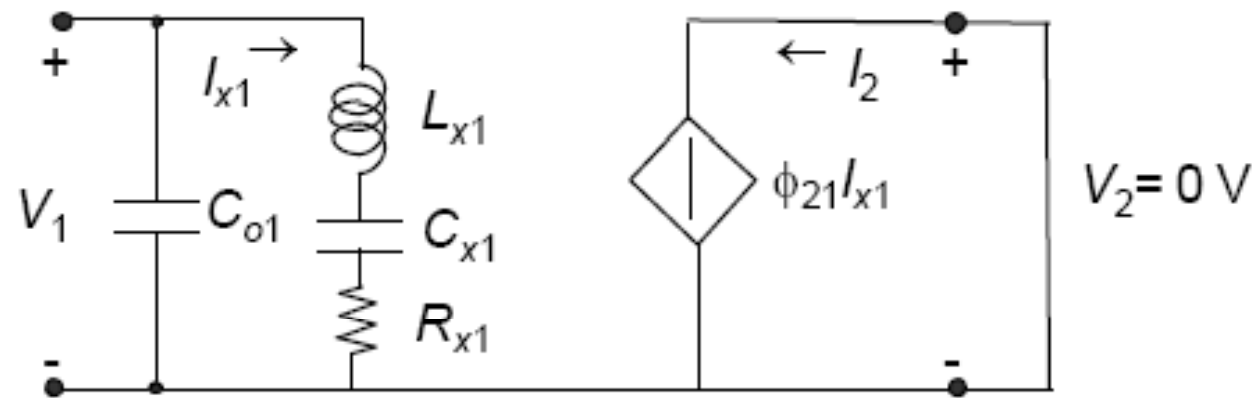

## Equivalent Circuit of 2-Port Resonator (in Electrical Domain)

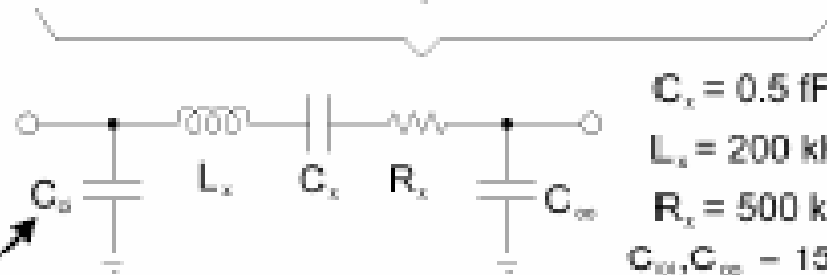
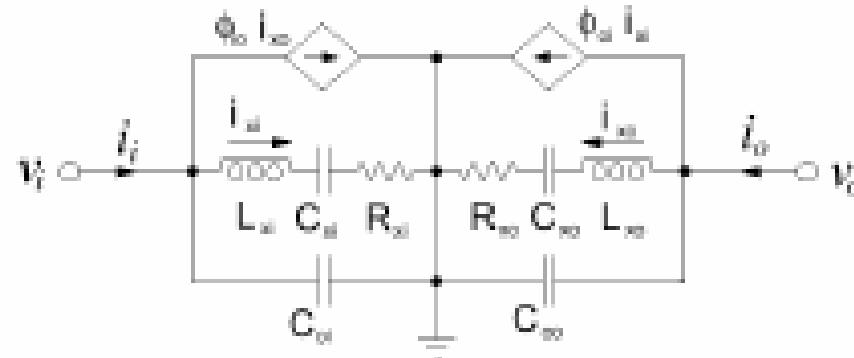

$C_x = 0.5 \text{ fF}$   
 $L_s = 200 \text{ nH}$   
 $R_s = 500 \text{ k}\Omega$   
 $C_{s1}, C_{s2} = 15 \text{ fF}$

Fixed electrical  
 Capacitance  
 Between fixed comb  
 And ground plane

$$C_{s1} = \frac{\eta_{s1}^2}{k} \quad R_{s1} = \frac{\sqrt{k m}}{Q \eta_{s1}^2} \quad \eta_{s1} = V_{ps} \frac{\partial C_s}{\partial x}$$

$$L_{s2} = \frac{m}{\eta_{s2}^2} \quad \phi_{s2} = \frac{\eta_{s2}}{\eta_{s1}}$$

C. T.-C. Nguyen, "Micromechanical resonators for oscillators and filters," Proceedings  
 IEEE International Ultrasonics Symposium, Seattle, WA, pp. 489-498, Nov. 7-10, 1996



## Discussion:



**FSRM**  
FUNDAMENTALS OF SURFACE  
ACOUSTIC WAVE DEVICES



**EPFL**  
ÉCOLE POLYTECHNIQUE  
FÉDÉRALE DE LAUSANNE

### Resonator equivalent circuit

Two types of currents possible:

- **from resonator motion** (should dominate!)
- from electrodes and resonator acting as pure electrical structure (from feedthrough capacitance)

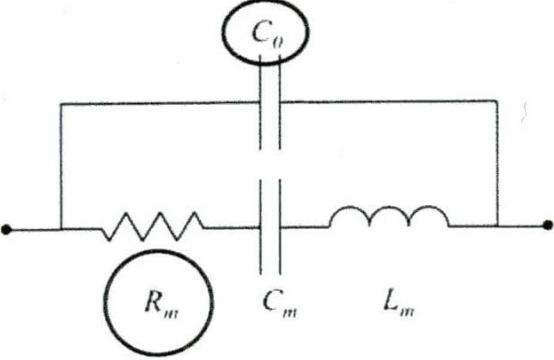

Admittance at resonance is

$$Y_{in} = \frac{1}{R_m} + j\omega_o C_o$$

where we want to minimize the motional resistance,  $R_m$  :

$$R_m = \frac{\sqrt{k * m}}{Q\eta^2} \quad \eta = V_{DC} \frac{dC}{dg} \quad \sim 1/g^2$$

- Need:
  - High Q
  - High coupling (high voltage or small gap)
  - Low mass
  - Low stiffness (!)

95

## Vertically-Driven Micromechanical Resonator

- To date, most used design to achieve VHF frequencies

Resonator Beam

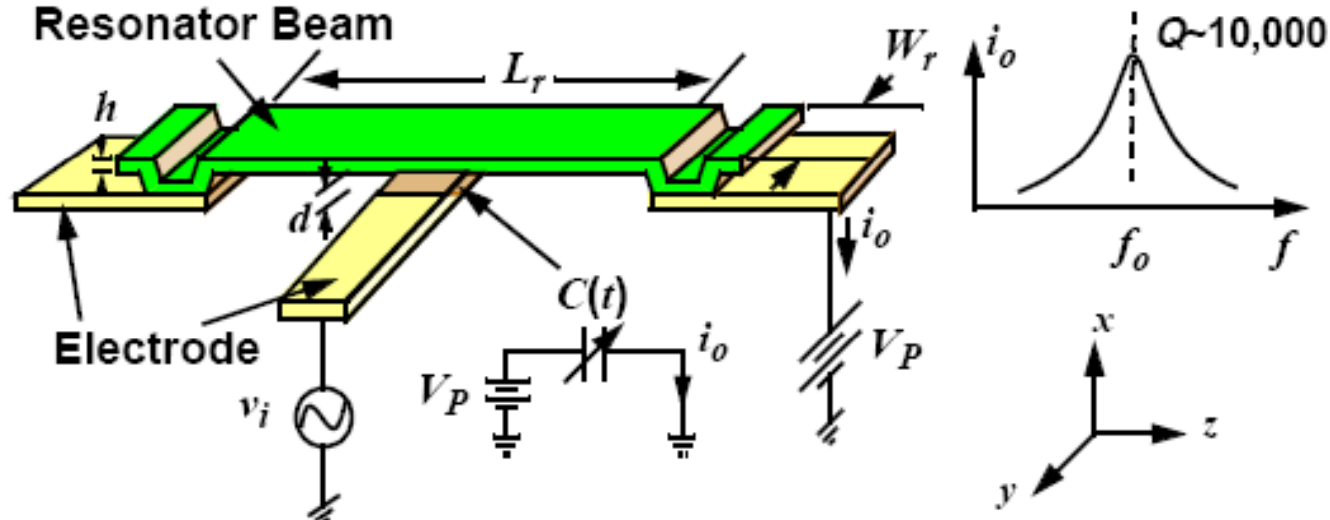

$$f_o = \frac{1}{2\pi} \sqrt{\frac{k_r}{m_r}} = 1.03 \sqrt{\frac{E}{\rho}} \frac{h}{L_r^2}$$

(e.g.  $m_r = 10^{-13}$  kg)

$E$  = Youngs Modulus  
 $\rho$  = density

- Smaller mass  $\Rightarrow$  higher frequency range and lower series  $R_x$

# Voltage-Controllable Center Frequency

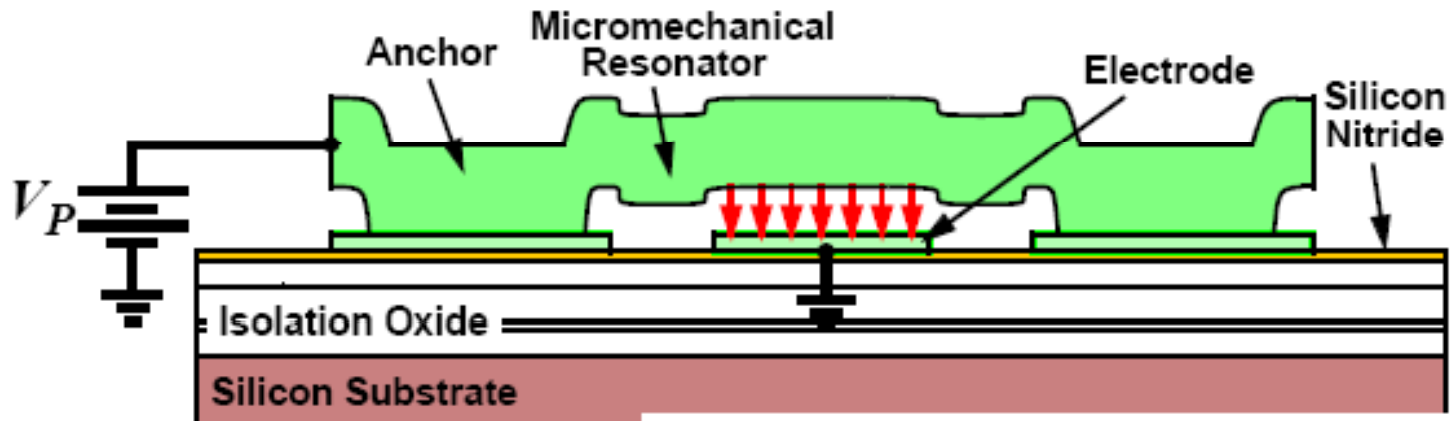

- Quadrature force  $\Rightarrow$  voltage-controllable electrical stiffness:

$$k_e = \frac{\epsilon_o A_o}{d^3} V_P^2$$

Finger Gap  $\rightarrow$   $d$       Electrode Overlap Area  $\rightarrow$   $A_o$

$$f_o = \frac{1}{2\pi} \sqrt{\frac{k_m - k_e}{m_r}}$$

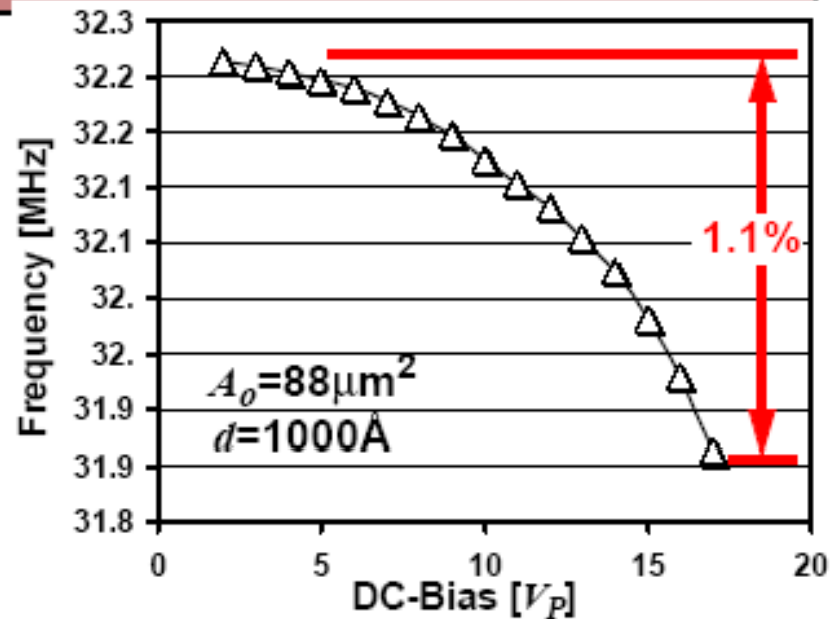

## Micromechanical Resonator Equivalent Circuit

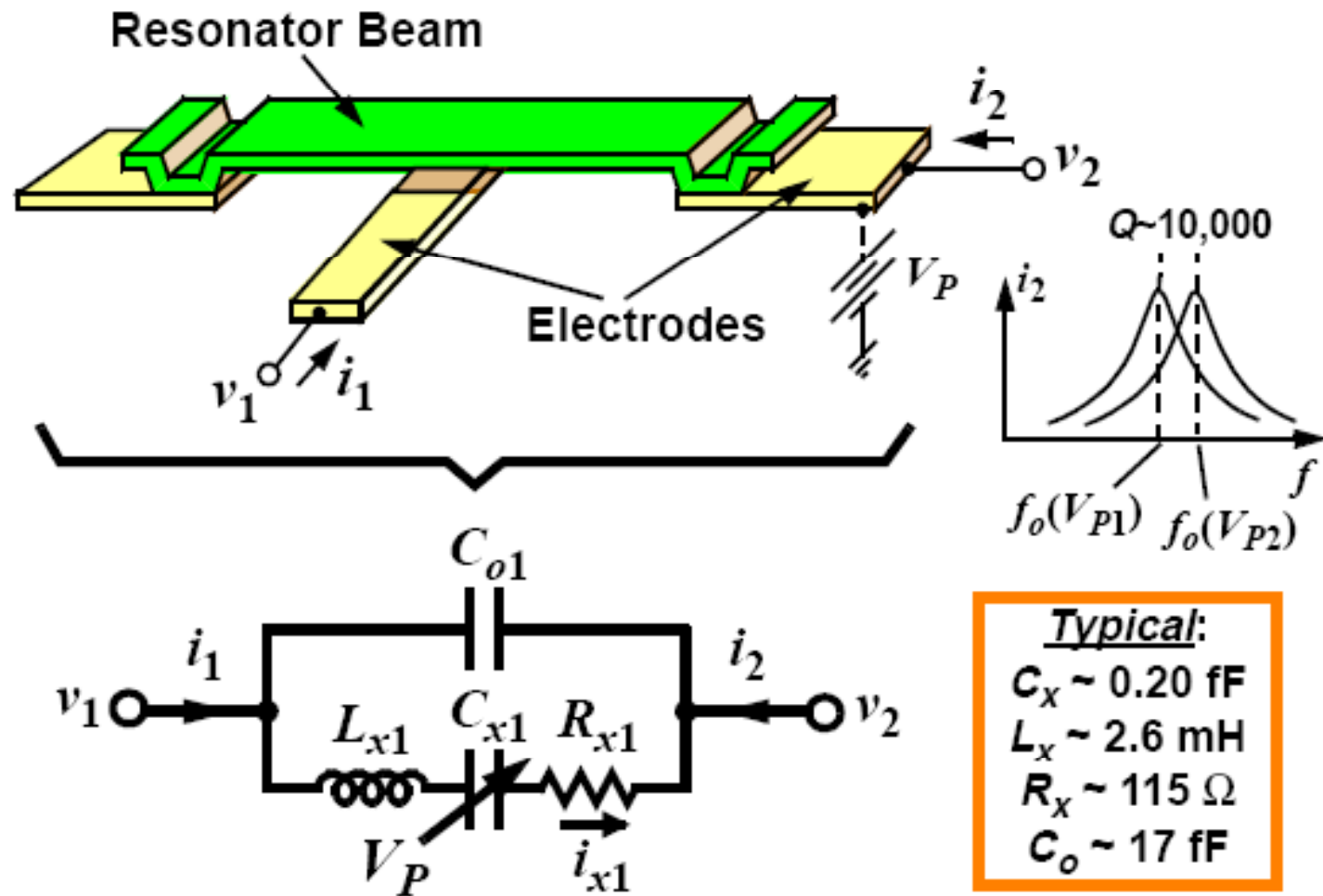

## Fabricated HF $\mu$ Mechanical Resonator

- Surface-micromachined,  $\text{POCl}_3$ -doped polycrystalline silicon

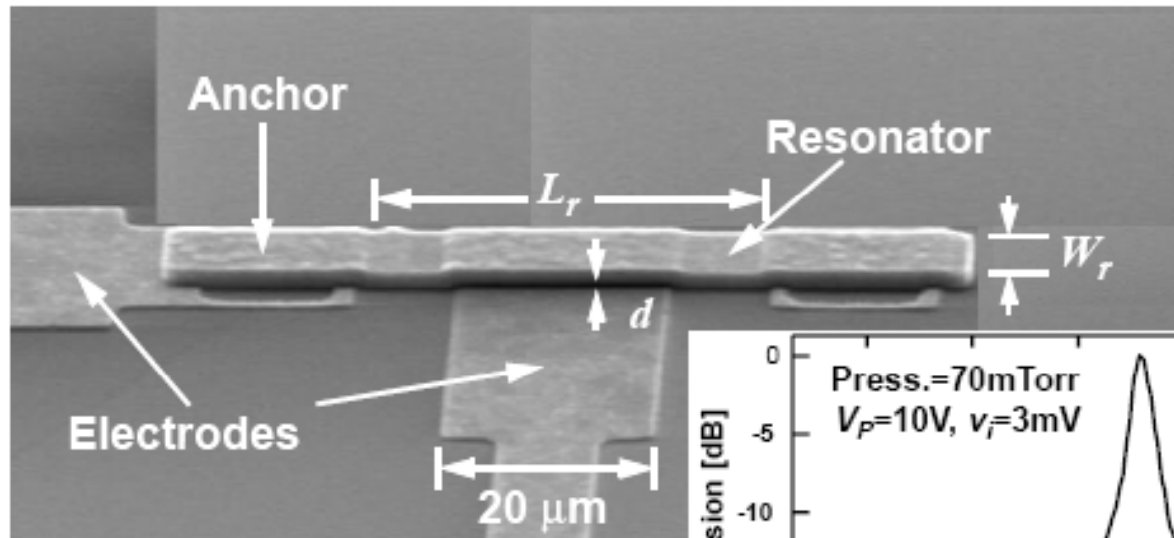

$L_r=40.8 \mu\text{m}$ ,  $W_r=8 \mu\text{m}$ ,  
 $h=2 \mu\text{m}$ ,  $d=0.1 \mu\text{m}$

- Extracted  $Q = 8,000$  (vacuum)
- Freq. influenced by dc-bias and anchor effects

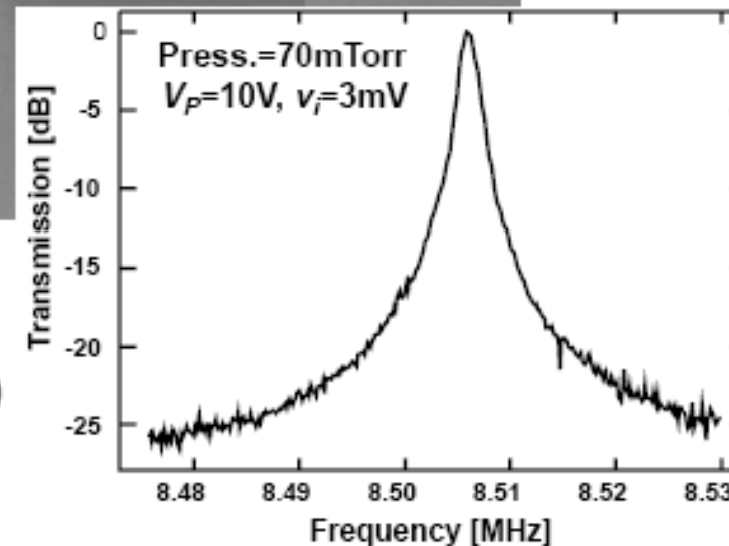



# Loss, c-c-beam

- Resonance frequency increases when the stiffness of a beam increases
  - Also: More energy pr. cycle enters the substrate via the anchors
- c-c-beam has loss through anchors
  - → Q-factor decreases when frequency increases
  - c-c-beam is not the best structure for high frequency!
  - Ex.  $Q = 8,000$  at 10 MHz,  $Q = 300$  at 70 MHz
- c-c beam may be used as a reference oscillator or HF/VHF filter/mixer
- **Use of "free-free beam" can reduce the energy loss via anchors to the substrate!**

# free-free-beam

- Beneficial for reducing loss to substrate via anchors
- f-f-beam is suspended using 4 support-beams in width-direction
  - Torsional support
  - Anchoring at nodes for "flexural mode"

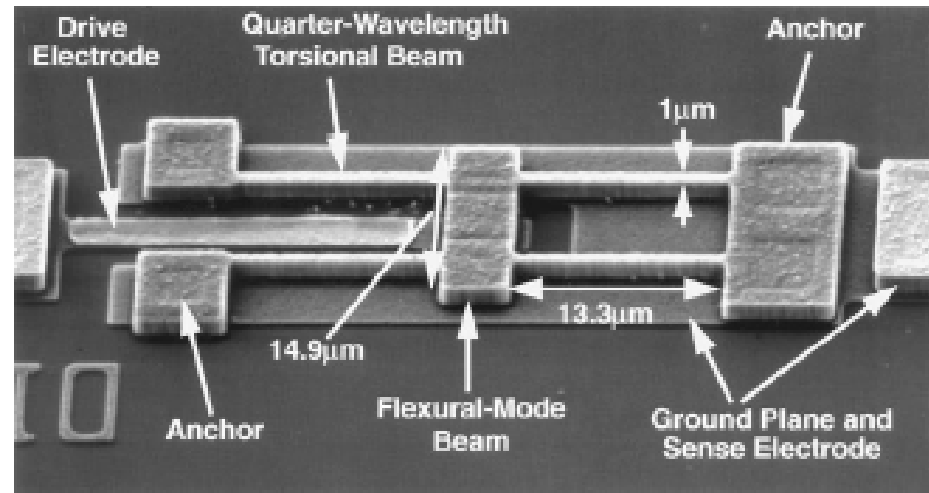

Fig. 29. SEM of free-free beam virtually levitated micromechanical resonator with relevant dimensions for  $f_0 = 71$  MHz.

# free-free-beam

- Support dimension is a quarter-wavelength of f-f-beam resonance frequency
  - The electrical impedance at the flexural nodes is then infinite
  - Beam vibrates without energy loss as if there is no support
- Higher Q is achieved
  - Ex.  $Q = 20,000$  at 10 – 200 MHz
  - Applied in reference-oscillators, HF/VHF-filter/mixer

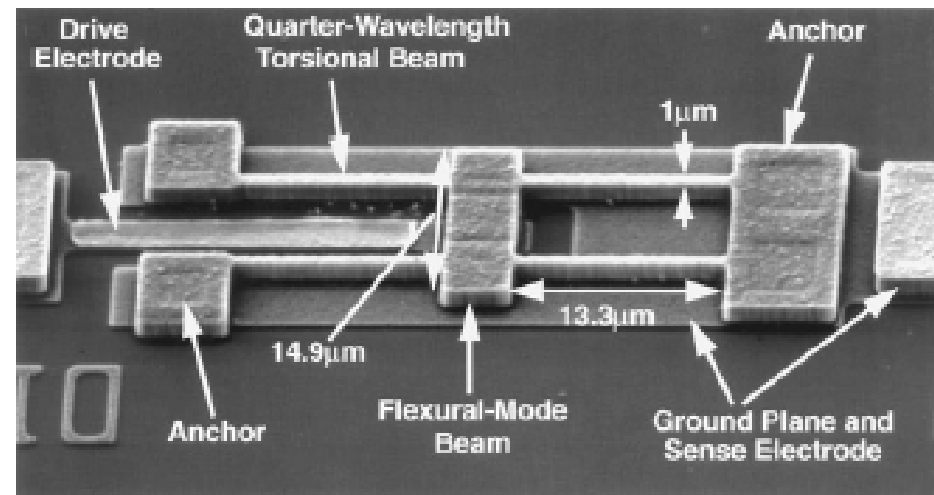
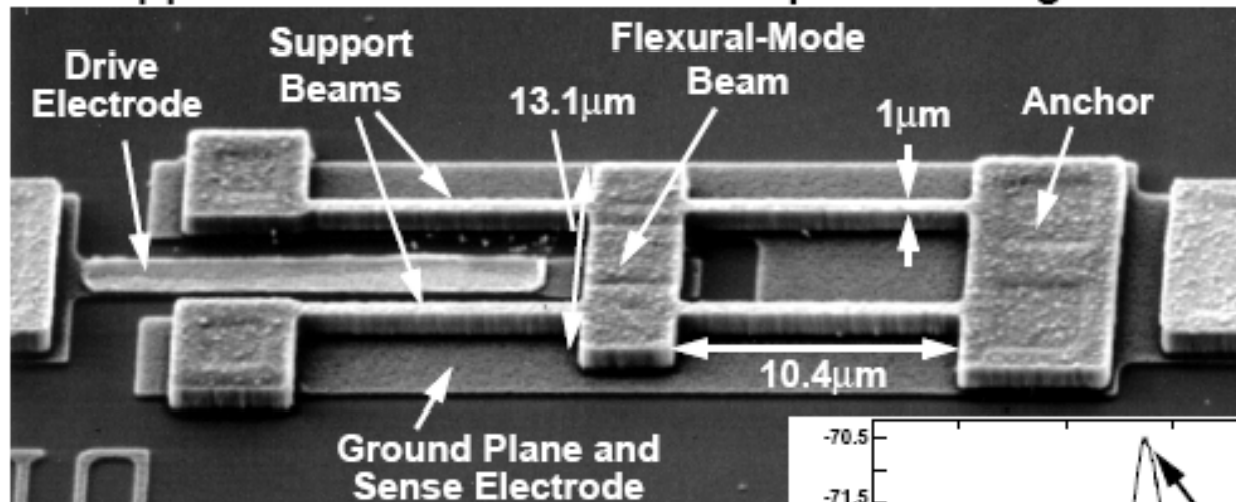

Fig. 29. SEM of free-free beam virtually levitated micromechanical resonator with relevant dimensions for  $f_0 = 71$  MHz.

## 92 MHz Free-Free Beam $\mu$ Resonator

- Free-free beam  $\mu$ mechanical resonator with non-intrusive supports  $\Rightarrow$  reduce anchor dissipation  $\Rightarrow$  higher  $Q$



### Design/Performance:

$L_r=13.1\mu\text{m}$ ,  $W_r=6\mu\text{m}$   
 $h=2\mu\text{m}$ ,  $d=1000\text{\AA}$   
 $V_p=28\text{V}$ ,  $W_e=2.8\mu\text{m}$   
 $f_o\sim 92.25\text{MHz}$   
 $Q\sim 7,450$  @ 10mTorr

[Wang, Yu, Nguyen 1998]

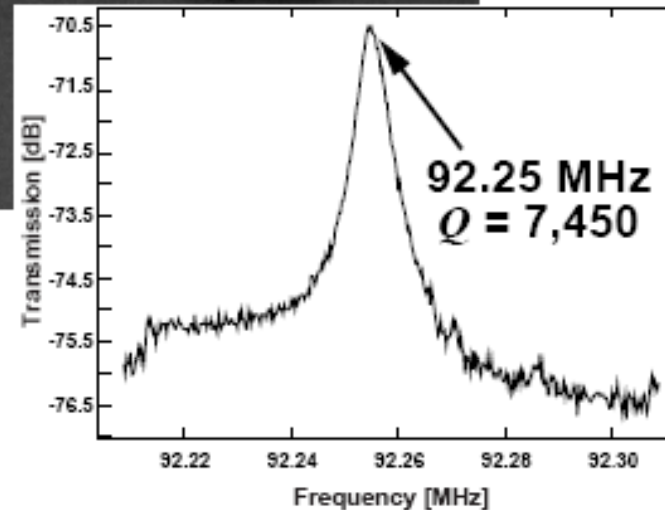

# VHF Free-Free Beam High-Q Micromechanical Resonator

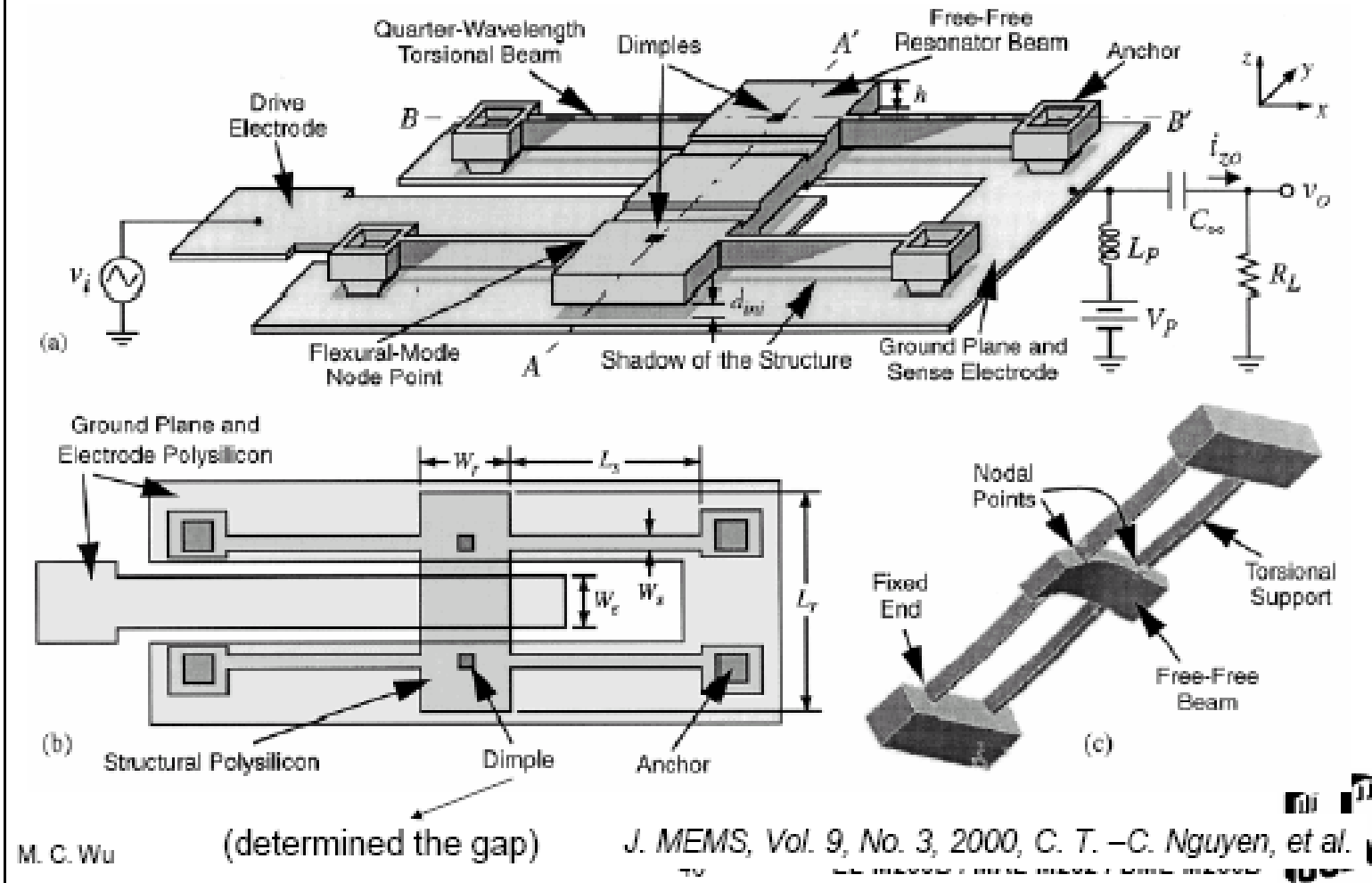

## Comparison of Frequency Characteristics

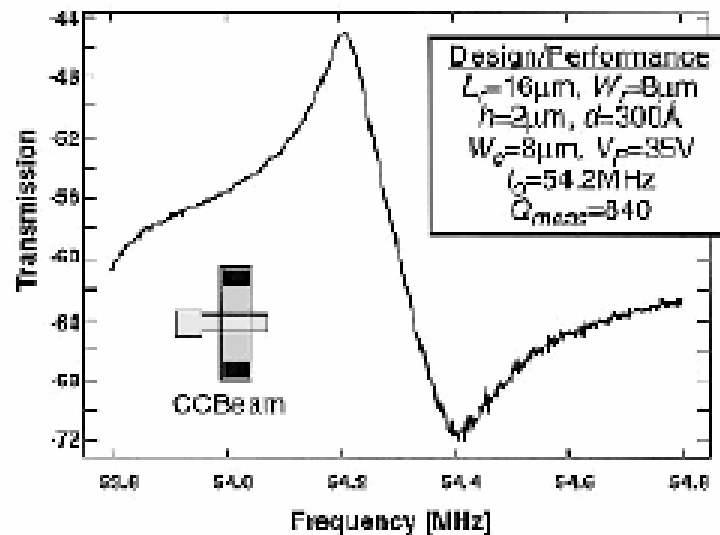

### Clamped-clamped beam

- $L_r=16\ \mu\text{m}$ ,  $d=0.03\ \mu\text{m}$
- $V_p=35\ \text{V}$ ,  $f_0=54.2\ \text{MHz}$
- $Q=840$

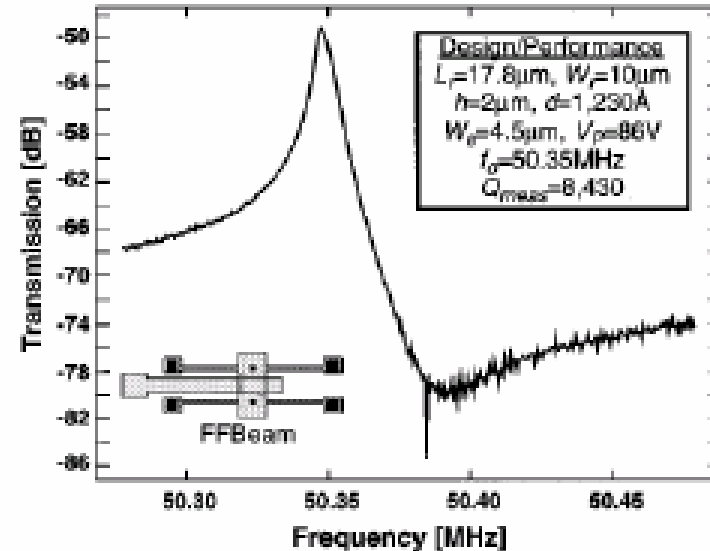

### Free-free beam

- $L_r=17.8\ \mu\text{m}$ ,  $d=0.12\ \mu\text{m}$
- $V_p=86\ \text{V}$ ,  $f_0=50.35\ \text{MHz}$
- $Q=8,430$

# Other resonator types

## Double-Ended Tuning Fork Resonators

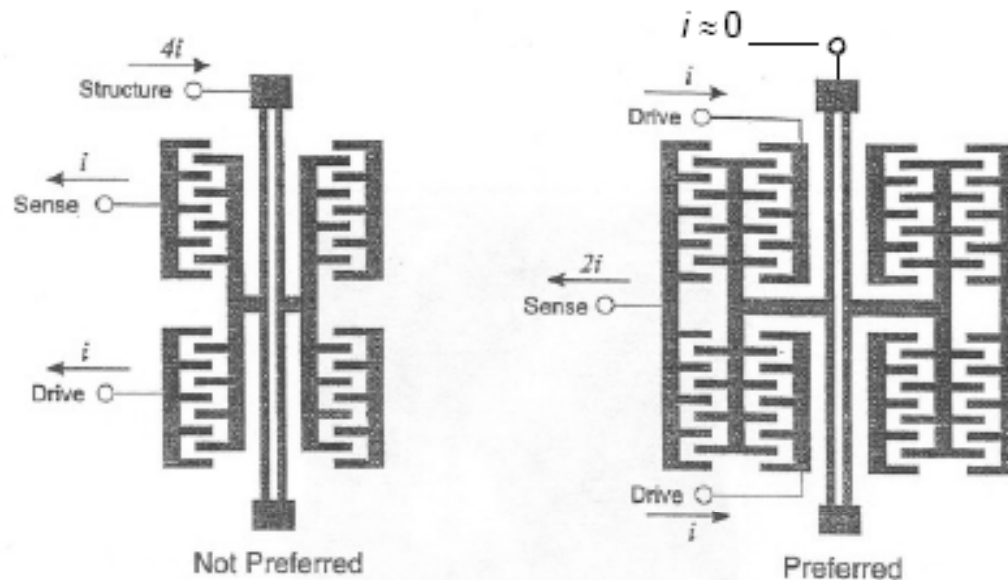

Current through structure  $\rightarrow$  more resistance (decreases  $Q$ )  
more feedthrough to substrate

**"Tuning fork"  $\rightarrow$  balanced (symmetrical)!**

## Scaling of Lateral Micromechanical Resonators

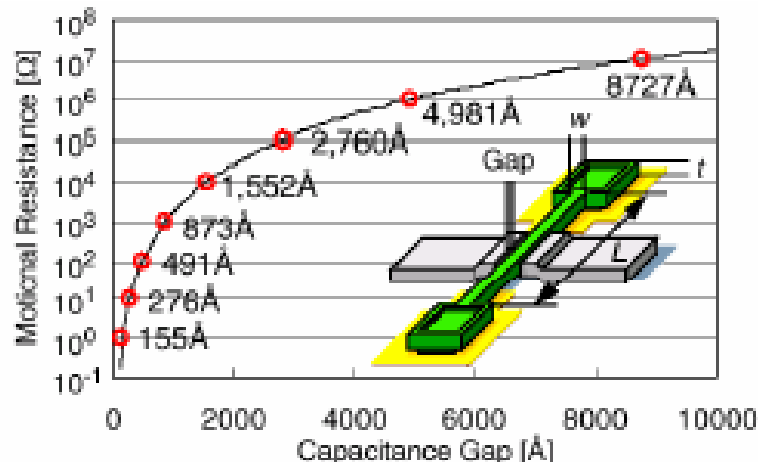

Fig. 1: Simulated plot of motional resistance versus electrode-to-resonator gap for a 40µm-long, 2µm-wide, 3µm-thick, lateral clamped-clamped beam µmechanical resonator.

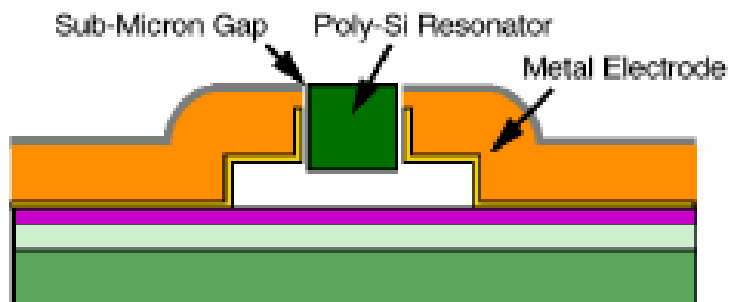

Fig. 2: Cross-section of the described sub-µm electrode-to-resonator gap process for lateral µstructures with metal electrodes.

- Advantages of lateral resonator
  - Wider variety of resonant modes
  - Balanced resonators (push-pull)
  - More design flexibility
- As frequency scales up
  - Resonator size shrinks
  - **Capacitive transducer gaps must also shrink** (to sub-100 nm for VHF)
  - High aspect ratio structures
- Combine Poly-Si (high-Q structural materials) with metal electrode (high conductivity)
  - Self-aligned process

Hsu, Clark, Nguyen, "A sub-micron capacitive gap process for multiple-metal-electrode lateral micromechanical resonators," MEMS 2001, p. 349



## Radial Contour-Mode Disk $\mu$ -mechanical Resonator

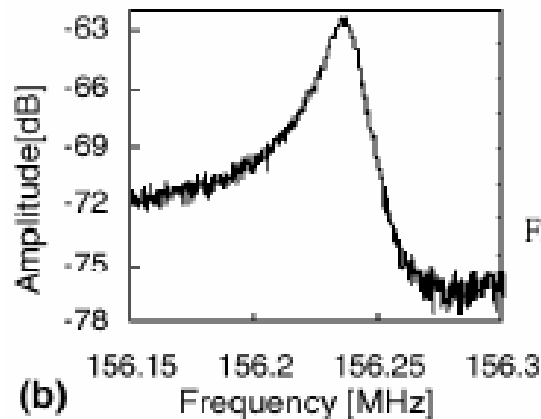
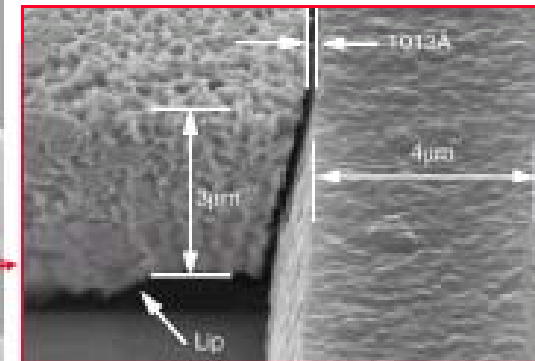
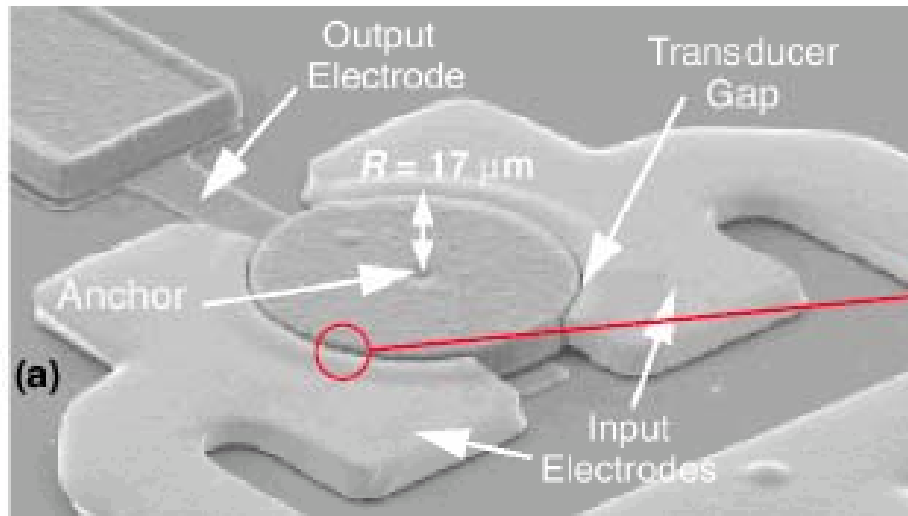

Data:  
 $R=17\mu\text{m}$ ,  $h=2\mu\text{m}$   
 $d=1,000\text{\AA}$ ,  $V_p=35\text{V}$   
 $f_0=156.23\text{MHz}$ ,  $Q=9,400$

Fig. 5: SEM and measured frequency characteristic for a 156.23 MHz contour-mode disk  $\mu$ mechanical resonator fabricated via the process of Fig. 3.

- Radial contour mode allows high resonant frequency without requiring sub-micron structures
- Place anchor at disk center – nodal point of contour mode  
 → Reduce mechanic loss and increase Q

Iisu, Clark, Nguyen, "A sub-micron capacitive gap process for multiple-metal-electrode lateral micromechanical resonators," MEMS 2001, p. 349

# Disk resonators

- Advantages of using disks compared to beams
  - Reduced air damping
    - Vacuum not needed to measure Q-factor
  - Higher stiffness
    - Higher frequency for given dimensions
  - Larger volume
    - Higher Q because more energy is stored
    - Less problems with thermal noise
- Periphery of the disk may have different motional patterns
  - Radial, wine-glass

## Increasing the Resonant Frequency

option 2. spring rate  $\rightarrow \infty$

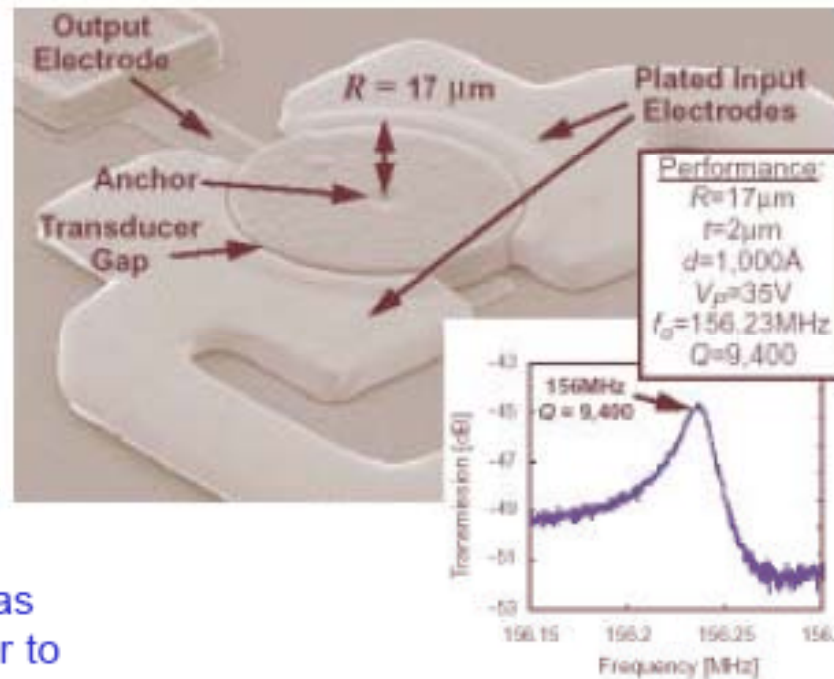

Clark Nguyen, Michigan

*Motivation:* keep mass as large as possible in order to improve precision of fab, power handling

IEEE IEDM 2000.

EE C245 – ME C218 Fall 2003 Lecture 27

19

# 1.14 GHz Poly-Si Disk Resonator

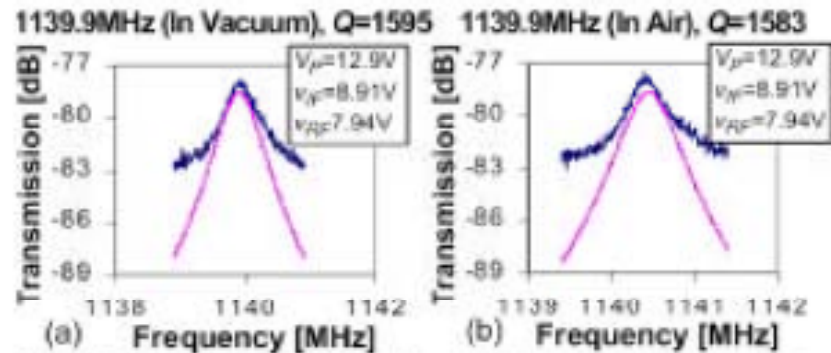
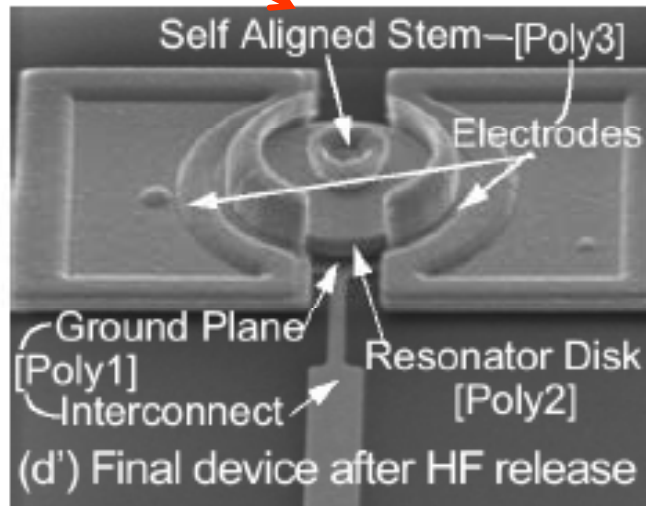

Fig. 7: Measured (dark) and predicted (light) frequency characteristics for a 1.14-GHz, 3rd mode, 20µm-diameter disk resonator measured in (a) vacuum and (b) in air, using a mixing measurement setup.

- \* Note Q in vacuum and in air is the same: little energy loss to ambient; however, energy loss through anchor ("stem") is significant
- \* EAM-like technique is used to extract the motional current.



# Bulk contour-mode resonators

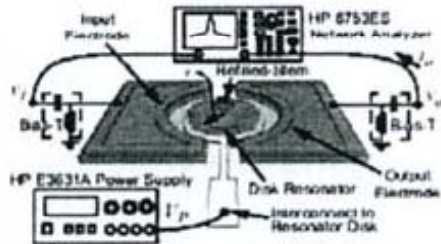
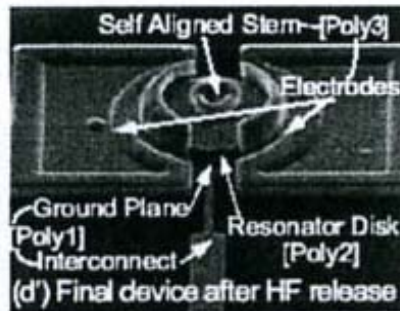
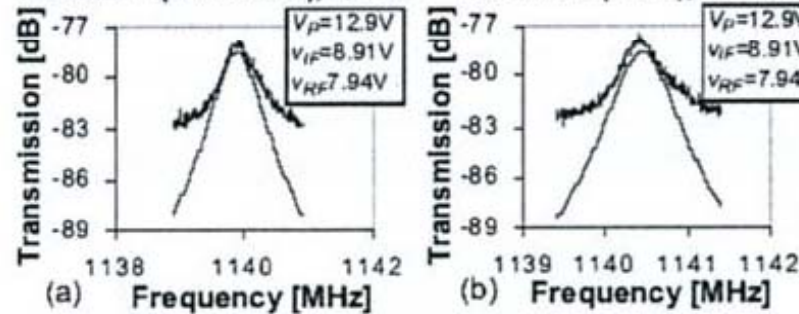

Fig. 1: Perspectives view schematic of a self-aligned disk resonator identifying key features and a two port measurement scheme



1139.9MHz (In Vacuum),  $Q=1595$       1139.9MHz (In Air),  $Q=1583$



- > 1GHz resonance frequency demonstrated
- $Q > 1'500$  in both vacuum and air
- $T_{coeff} \sim -15ppm/^{\circ}C$

J. Wang et al, Transducers 2003.

- Bulk acoustic mode resonators / contour-mode disk resonators
- Frequency range: tens of kHz to GHz
- Quality factors > 10'000 for single crystal silicon demonstrated
- Further developments: process with nano-gaps  $\rightarrow$  GHz frequency

# Limitations of micromechanical resonators

- Frequency limitations
  - By **reducing  $m$**  to obtain higher frequencies:
  - This will give fluctuations in frequency
    - "mass loading": interchange of molecules with environment
    - Air gas molecules have Brownian motion
- Energy limitations
  - $Q$  depends on **energy loss** caused by damping
    - Viscous damping
    - Vertical motion: squeezed-film damping
    - Horizontal motion: slide film damping, Stokes- or Couette-type damping

# Limitations, contd.

- Temperature dependence
  - Resonance frequency changes due to temperature and aging
  - Increased temperature gives frequency decrease
    - Analog or digital **compensation** (feedback)
    - **Mechanical compensation**
      - Exploit structures with both compressive and tensile stress: opposing effects →

# Temperature compensation

- Top-electrode **modifies** effective spring constant because  $V_C$  causes an electrostatic attraction
- Top-electrode will be elevated (gap increases) when the temperature increases → reduction of el. spring constant
- Generally the mechanical spring constant **decreases** by increased temperature. But the **reduction will be less** due to the effect of the top electrode (e.g. the "beam-softening"-effect is reduced)!

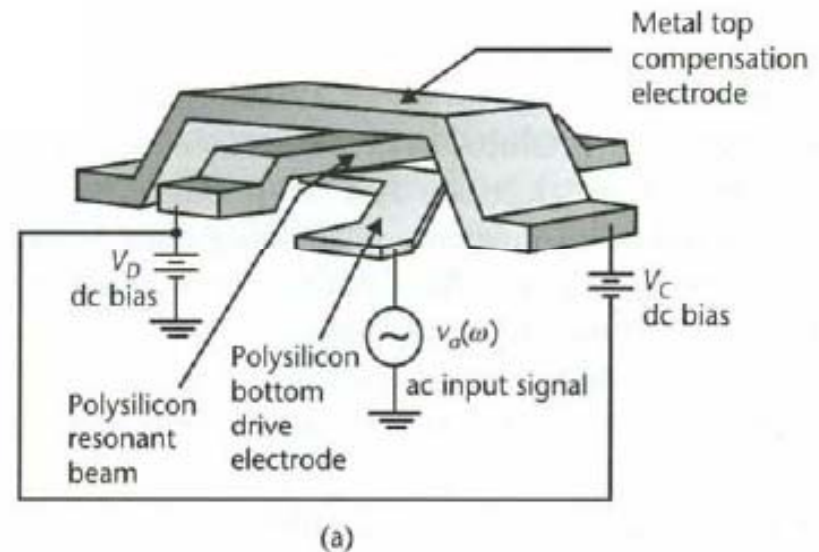



## Temperature compensation

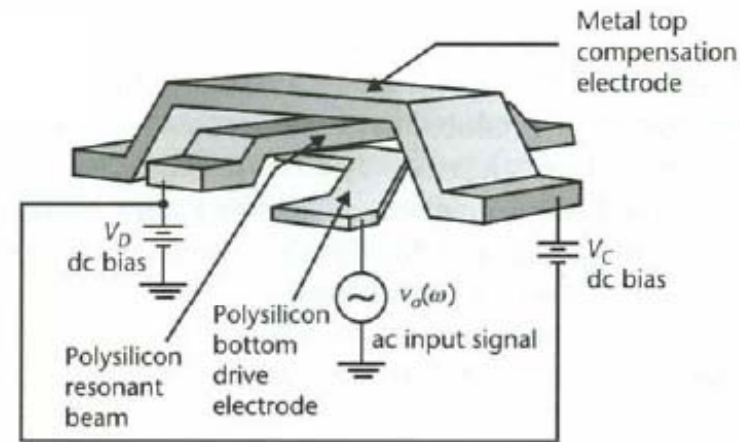

(a)

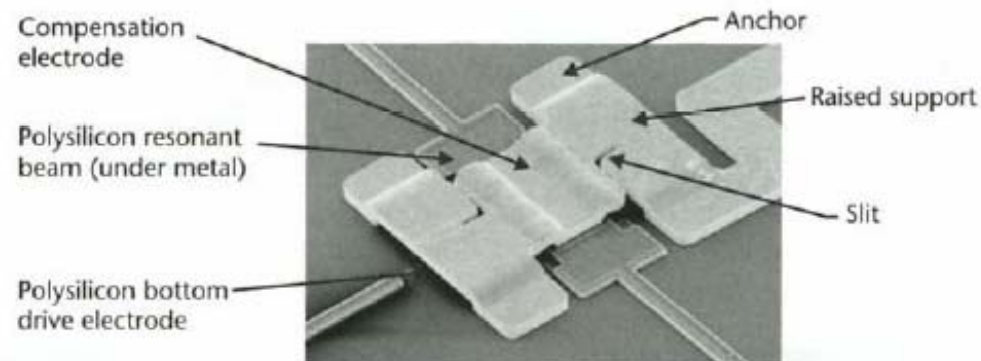

(b)

**Figure 7.11** Illustration of the compensation scheme to reduce sensitivity in a resonant structure to temperature. A voltage applied to a top metal electrode modifies through electrostatic attraction the effective spring constant of the resonant beam. Temperature changes cause the metal electrode to move relative to the polysilicon resonant beam, thus changing the gap between the two layers. This reduces the electrically induced spring constant opposing the mechanical spring while the mechanical spring constant itself is falling, resulting in their combination varying much less with temperature. (a) Perspective view of the structure [23], and (b) scanning electron micrograph of the device. (Courtesy of: Discera, Inc., of Ann Arbor, Michigan.)

# MEMS resonator architectures

▨ = fixed part

Basic flexural resonator types

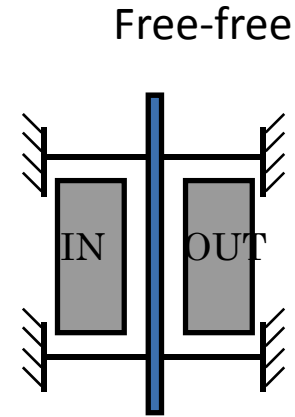
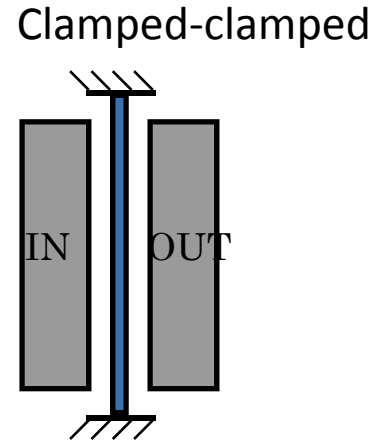
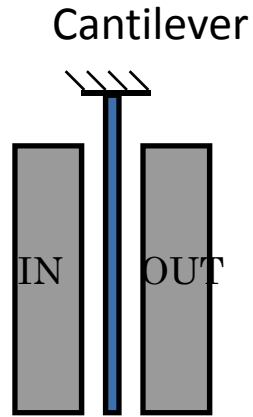

Resonator variants based on the basic types

CCSFR

Clamped-clamped  
Square-Frame Resonator

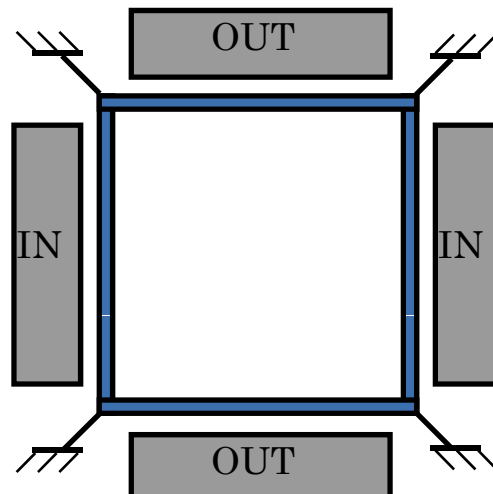

FFSFR

Free-free  
Square-Frame Resonator

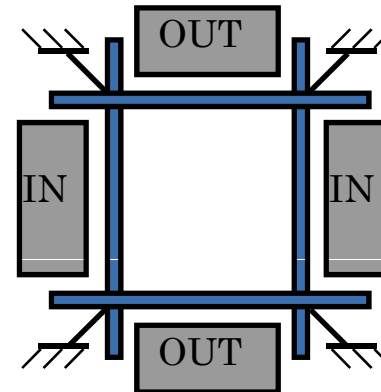

# FFSFR architecture

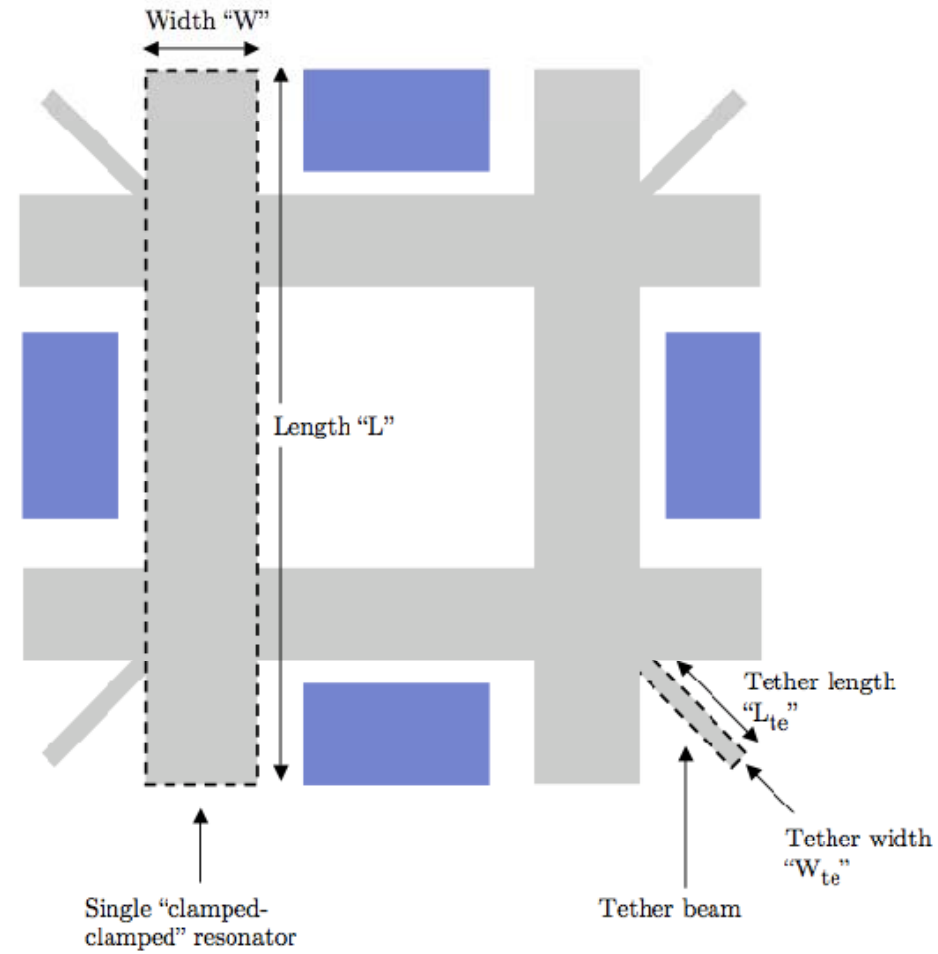

# Free-free Square Frame Resonator

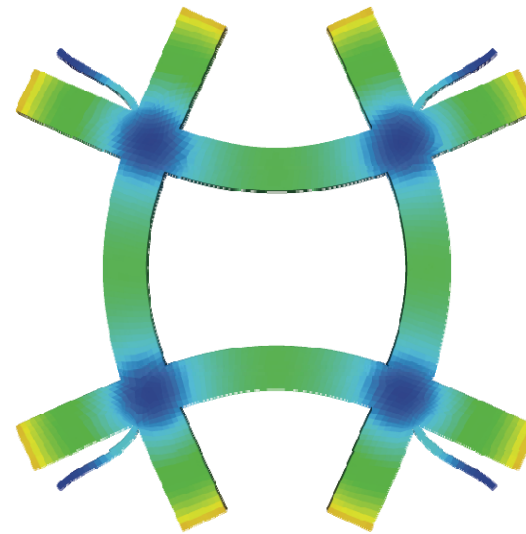
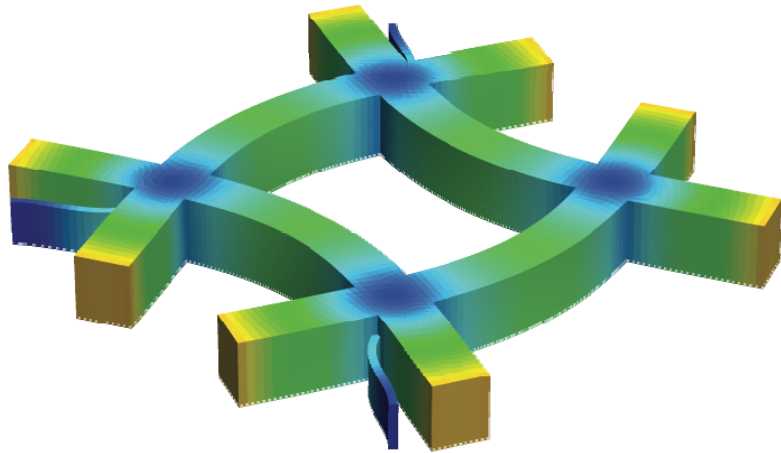

# FFSFR w/self-assembly electrodes

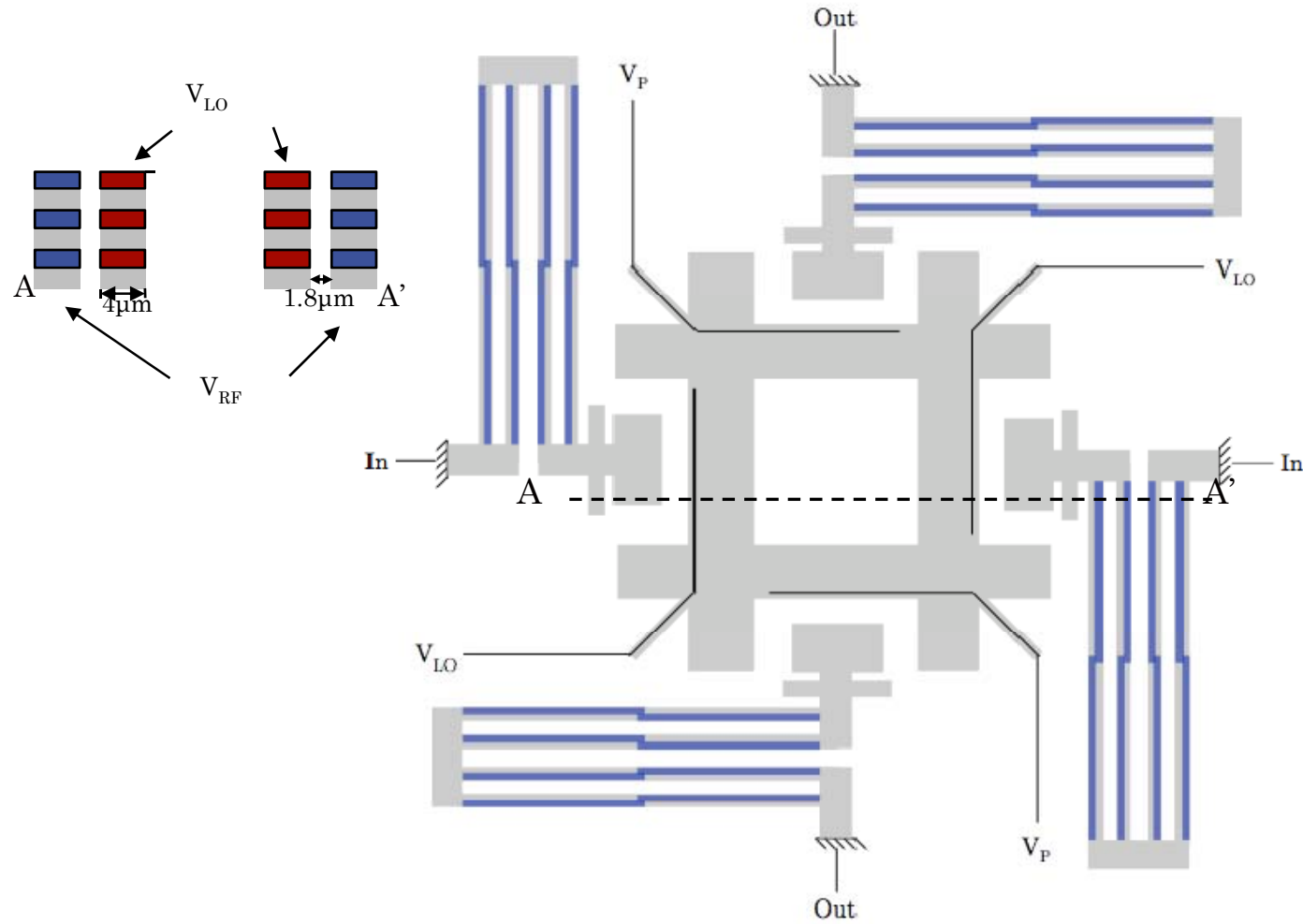

# SFR filter silicon etched

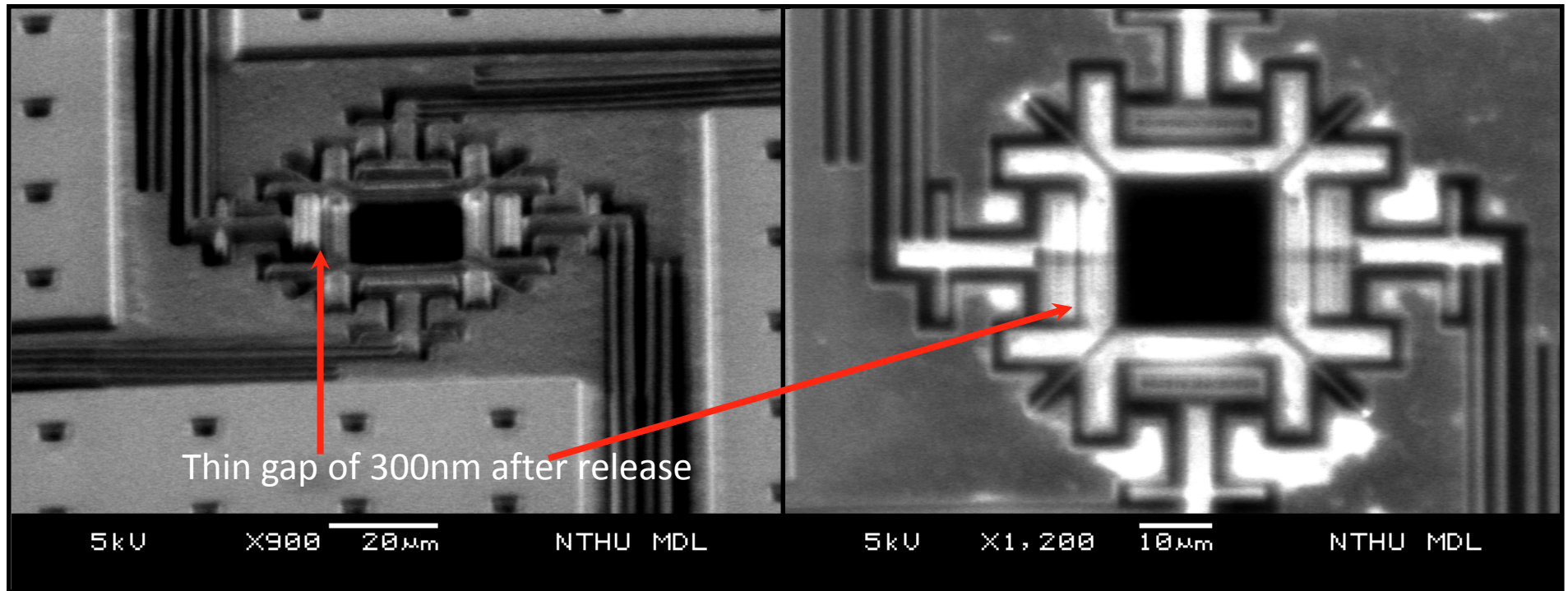

# Layout

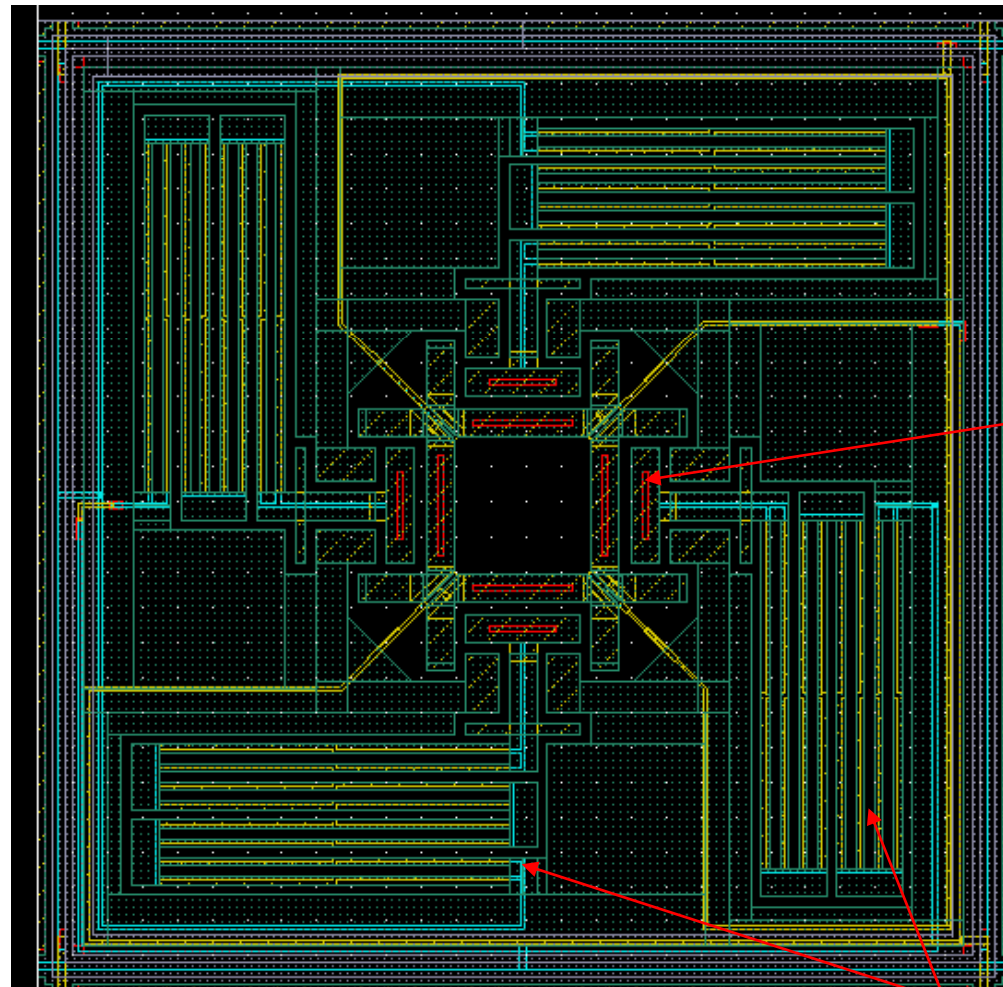

Square-Frame Resonator

Self-assembly electrode

# Total system simulation (calibre)

AC Response

