

INF 5490 RF MEMS

LN10: Micromechanical filters

Spring 2012, Oddvar Søråsen
Department of Informatics, UoO

Today's lecture

- Properties of mechanical filters
- Visualization and working principle
- Modeling
- Examples
- Design procedure
- Mixer

Mechanical filters

- Well-known for several decades
 - Jmfr. book: "Mechanical filters in electronics", R.A. Johnson, **1983**
- **Miniaturization** of mechanical filters makes it more interesting to use
 - Possible by using [micromachining](#)
 - Motivation → Fabrication of small integrated filters: "system-on-chip" with good filter performance

Filter response

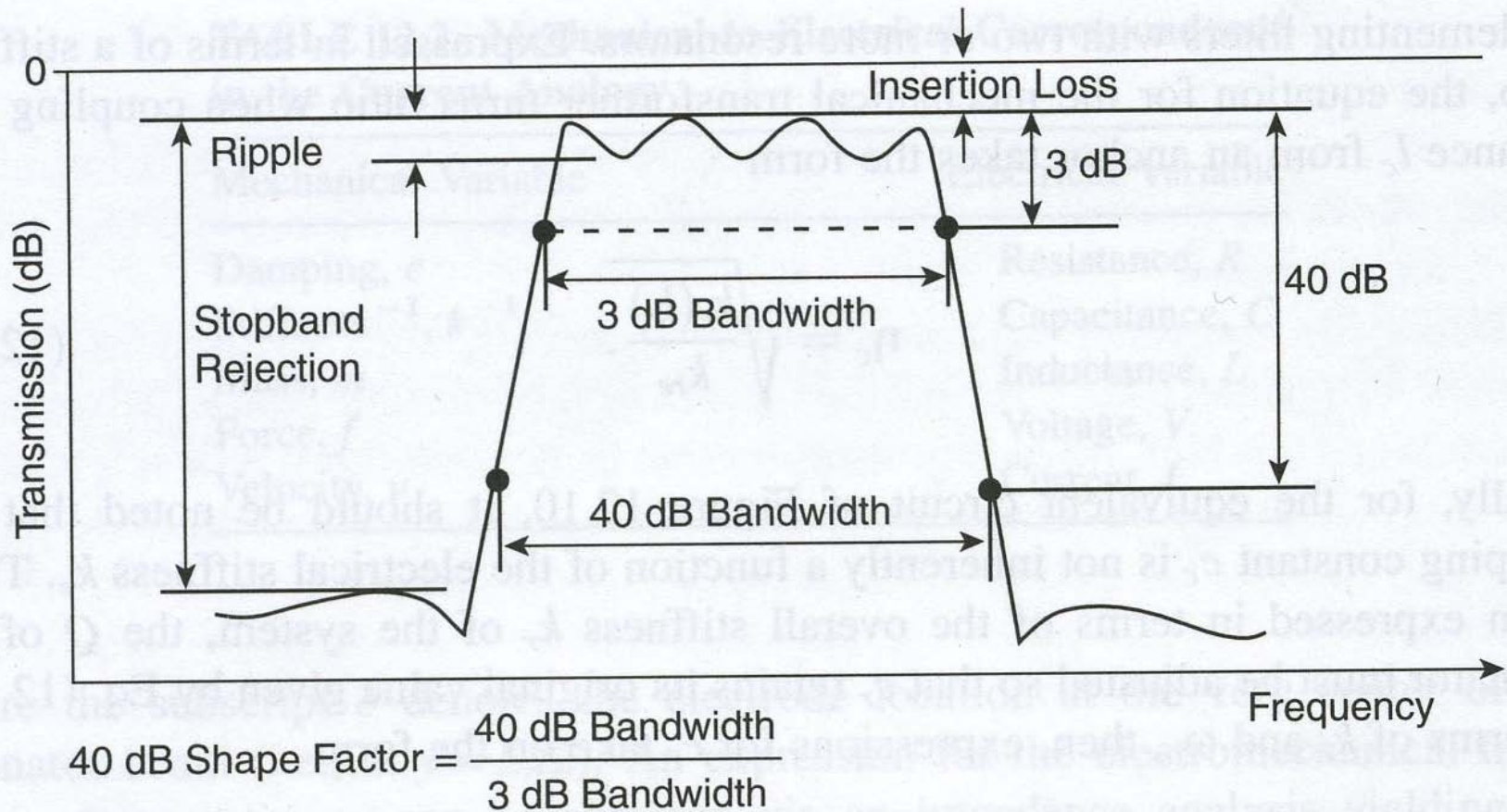

Figure 12.11. Parameters typically used for filter specification. (From reference [29])

Several resonators used

- One **single** resonator has a narrow BP-response
 - Good for defining oscillator frequency
 - Not good for BP-filter
- BP-filters are implemented by coupling resonators in cascade
 - Gives a wider pass band than using one single resonating structure
 - 2 or more micro resonators are used
 - Each of comb type or c-c beam type (or other types)
 - **Connected by soft springs**

Filter order

- Number of resonators, n , defines the filter **order**
 - Order = $2 * n$
 - Sharper "roll-off" to stop band when several resonators are used
 - → "sharper filter"

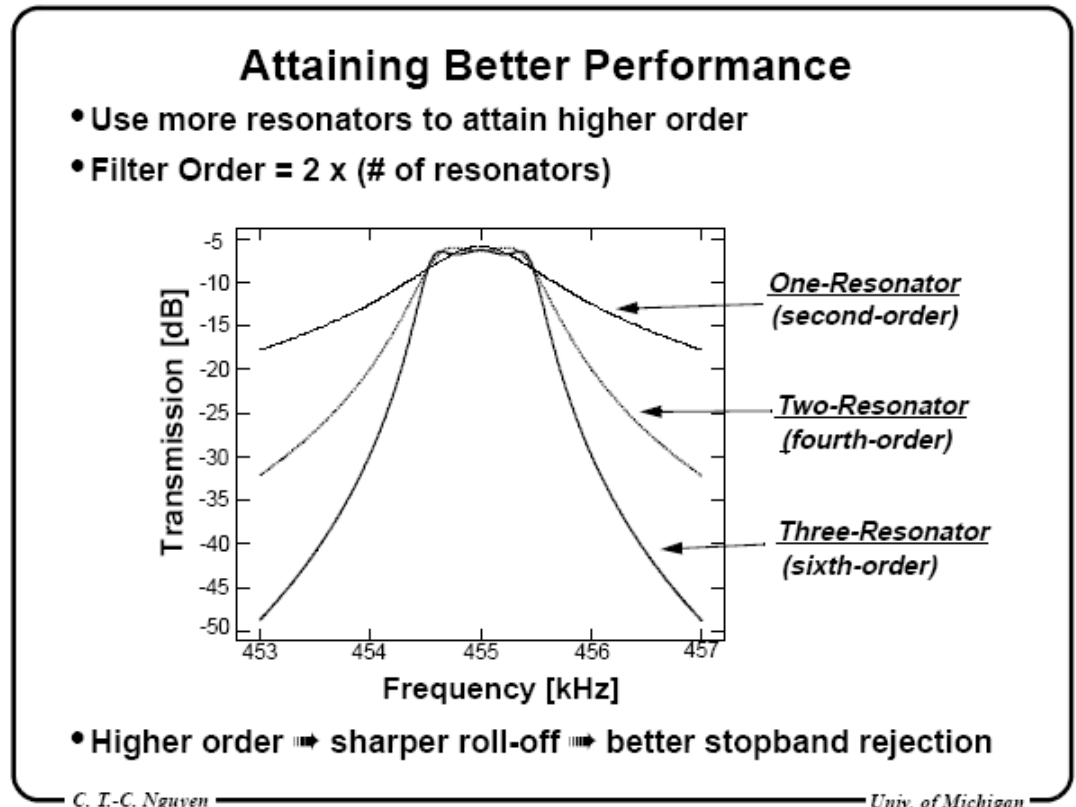

Micromachined filter properties

- **+ Compact** implementation
 - "on-chip" filter bank possible
- **+ High Q-factor** can be obtained
- **+ Low-loss BP-filters** can be implemented
 - The individual resonators have low loss
 - Low total "Insertion loss, IL"
 - IL: Degraded for small bandwidth →
 - IL: Improved for high Q-factor →

”Insertion loss”

IL: Degraded for small bandwidth

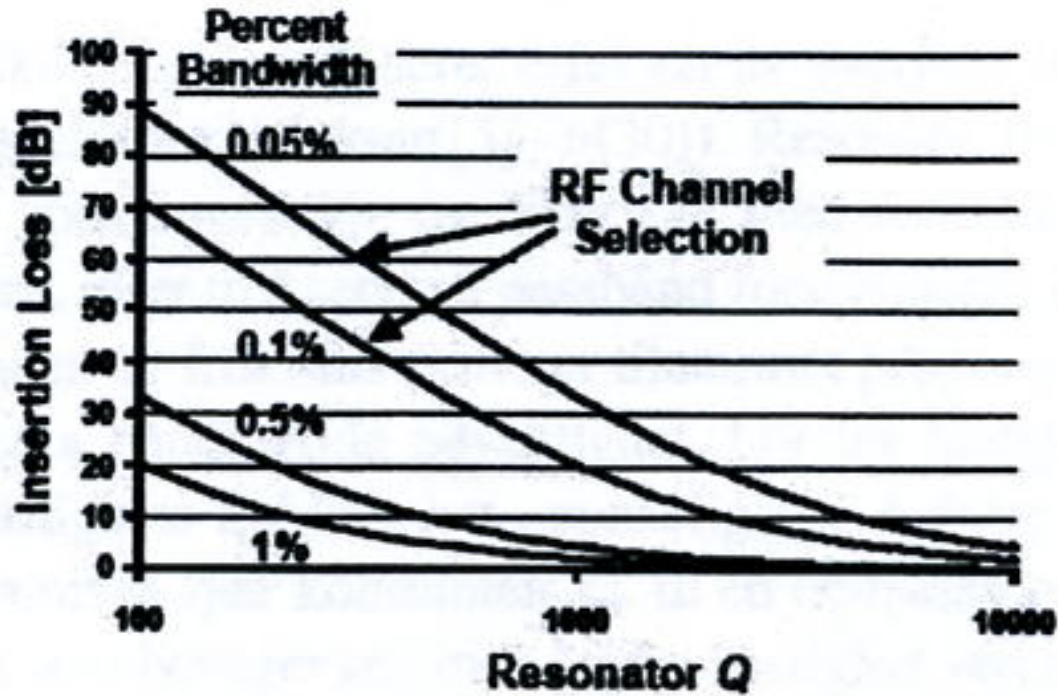

IL: Improved for high Q-factor

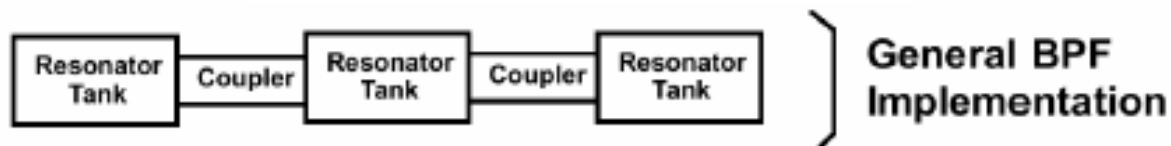

Typical LC implementation:

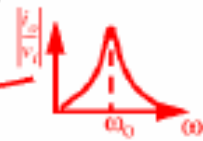
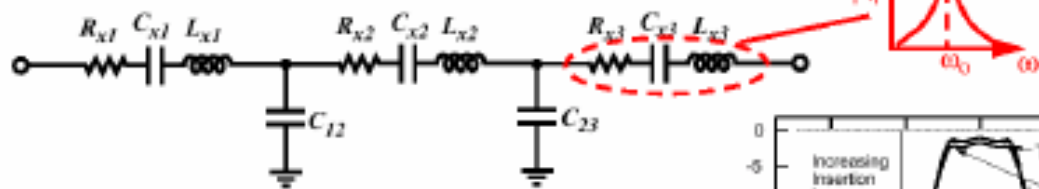

- In resonator-based filters: high tank $Q \Leftrightarrow$ low insertion loss
- At right: a 0.3% bandwidth filter @ 70 MHz (simulated) — heavy insertion loss for resonator $Q < 5,000$

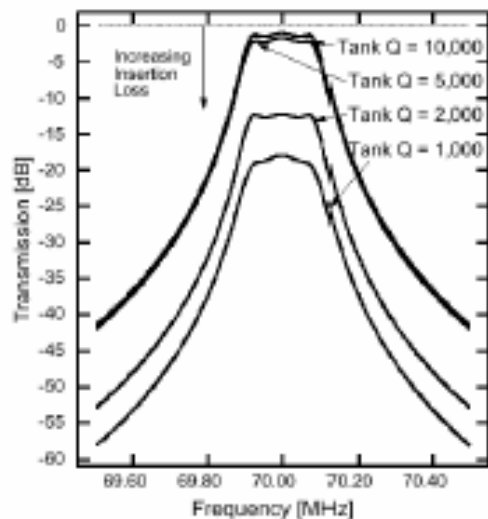

Mechanical model

- A **coupled resonator system** has several **vibration modes**
- n independent resonators
 - Resonates at their natural frequencies determined by m, k
 - **”compliant”** (soft) coupling springs
 - Determine the resulting **resonance modes** of the many-body system

Visualization of the working principle

- 2 oscillation modes
 - **In phase:**
 - No relative displacement between masses
 - No force from coupling spring
 - Oscillation frequency = natural frequency for a single resonator (both are equal, - “**mass less**” coupling spring*)
 - (* actual coupling spring mass can lower the frequency)

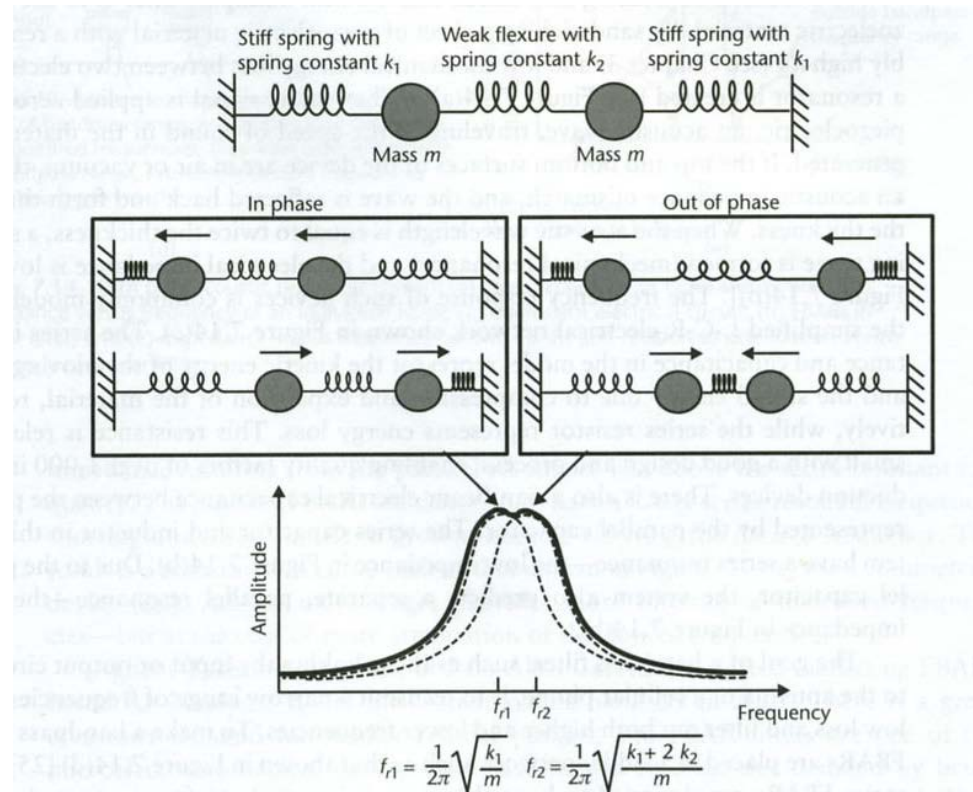

Figure 7.13 Illustration of two identical resonators, each with a mass and spring, coupled by a weak and compliant intermediate flexure. The system has two resonant oscillation modes, for in-phase and out-of-phase motion, resulting in a bandpass characteristic.

Visualization of the working principle

- **Out of phase:**
- Displacement in opposite directions
- Force from coupling spring (added force)
- Gives a higher oscillation frequency (Newton's 2.law, $F=ma$)
- → the 2 overlapping resonance frequencies are **split** into 2 distinct frequencies

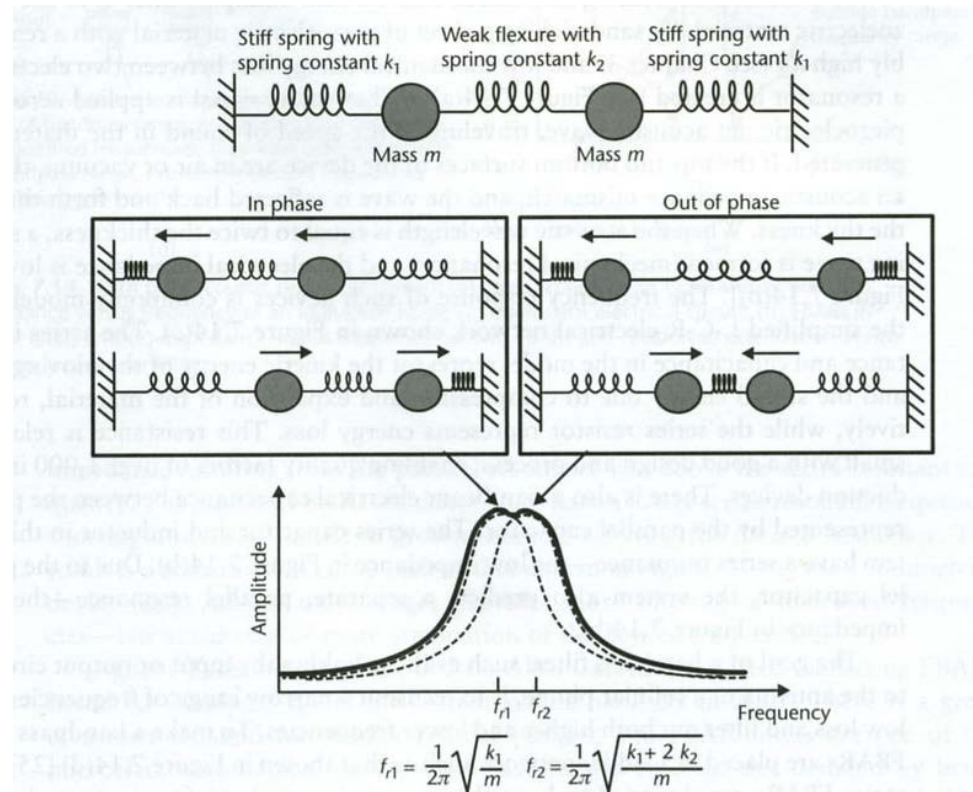

Figure 7.13 Illustration of two identical resonators, each with a mass and spring, coupled by a weak and compliant intermediate flexure. The system has two resonant oscillation modes, for in-phase and out-of-phase motion, resulting in a bandpass characteristic.

3-resonator structure

- Each vibration mode corresponds to a **distinct top** in the frequency response
 - Lowest frequency: all in phase
 - Middle frequency: center not moving, ends out of phase
 - Highest frequency: each 180 degrees out of phase with neighbour

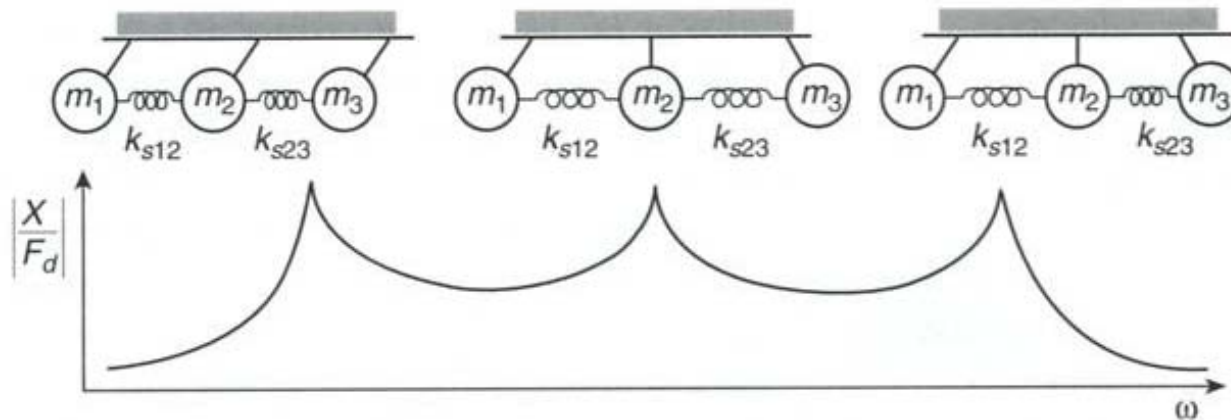

Figure 12.13. Mode shapes of a three-resonator micromechanical filter and their corresponding frequency peaks.

Illustrating principle: 3 * resonators

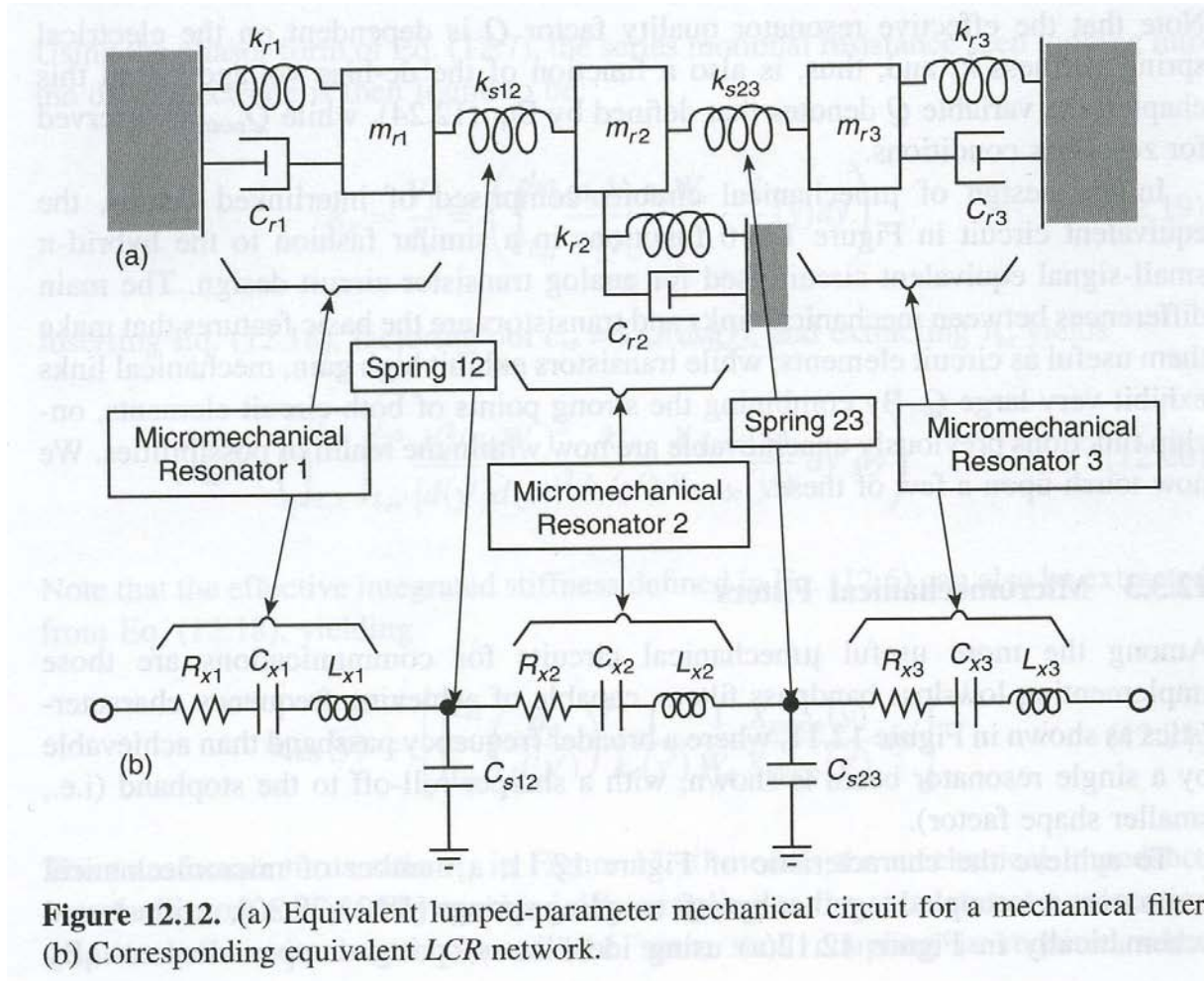
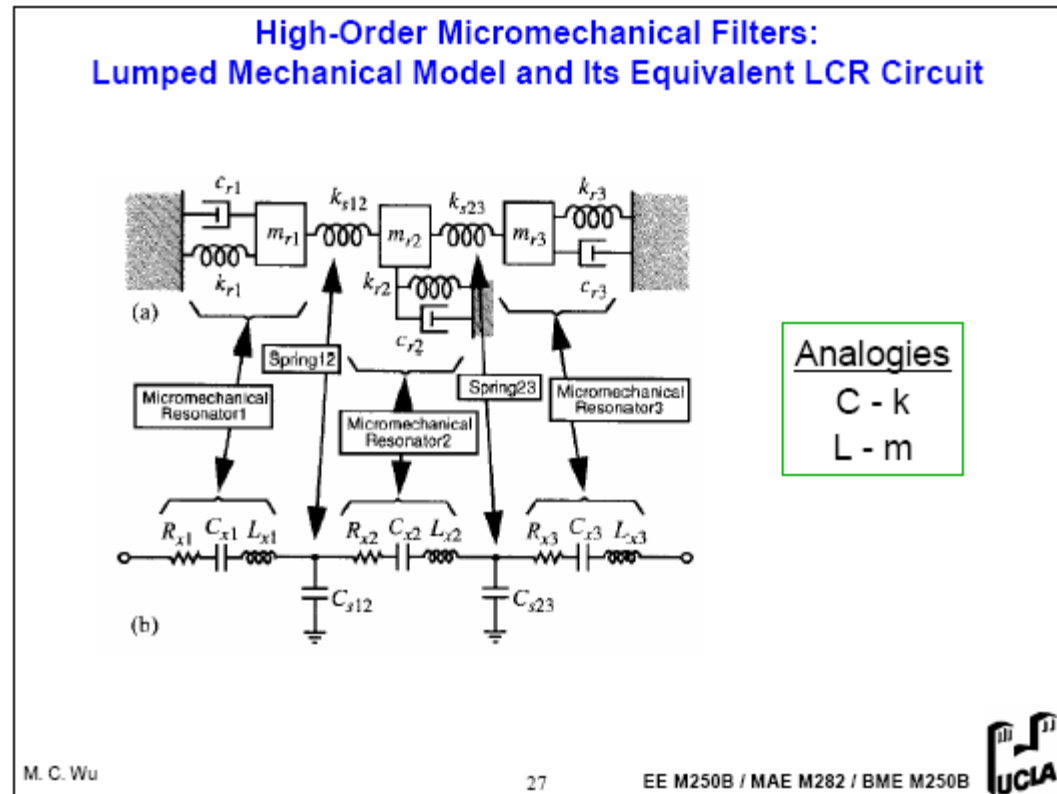

Figure 12.12. (a) Equivalent lumped-parameter mechanical circuit for a mechanical filter. (b) Corresponding equivalent LCR network.

Mechanical or electrical design?

- Much similarity between description of mechanical and electrical systems
- The **dual** circuit to a "spring-mass-damper" system is a **LC-ladder network** →
 - Electromechanical analogy used for conversion
 - Each resonator a LCR tank
 - Each coupling spring (idealized massless) corresponds to a shunt capacitance



Modeling

- Systems can be modeled and designed in **electrical domain** by using procedures from coupled resonator "ladder filters"
 - All polynomial syntheses methods from electrical filter design can be used
 - A large number of syntheses methods and tables exist + electrical circuit simulators
 - Butterworth, Chebyshev -filters
- Possible procedure: Full synthesis in the electrical domain and **conversion** to mechanical domain as the last step
 - LC-elements are mapped to lumped mechanical elements
- **Possible, but generally not recommended**
 - → knowledge from both electrical and mechanical domains should be used for **optimal filter design**

2-resonator HF-VHF micromechanical filter

- The coupled resonator filter may be classified as a 2-port:
 - Two c-c beams
 - 0.1 μm over substrate
 - Determined by thickness of "sacrificial oxide"
 - Soft coupling spring
 - polySi stripes under each resonator \rightarrow electrodes
 - Vibrations normal to substrate
 - DC voltage applied
 - polySi at the edges function as **tuning electrodes**
 - ("beam-softening")

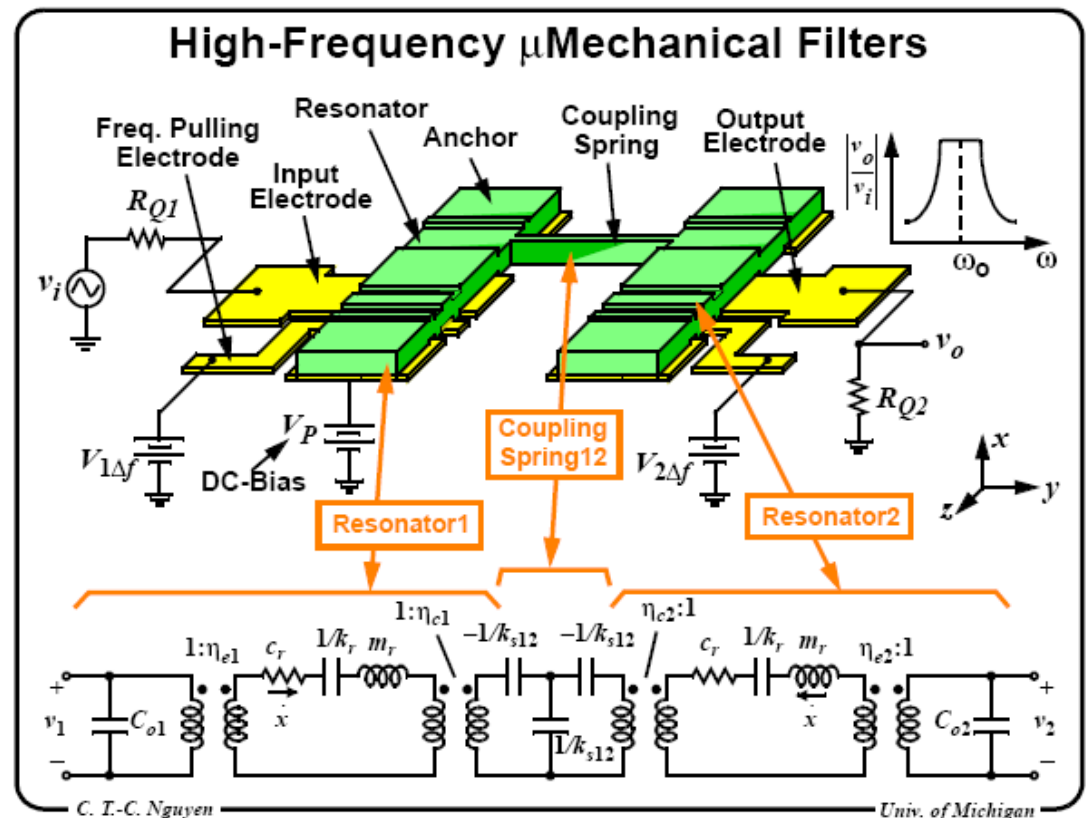

Resistors

- AC-signal on input electrode through R_{Q1}
 - R_{Q1} reduces overall Q and makes the pass band more flat
- Matched impedance at output, R_{Q2}
 - R' s may be tailored to specific applications
 - e.g. may be adjusted for interfacing to a following LNA

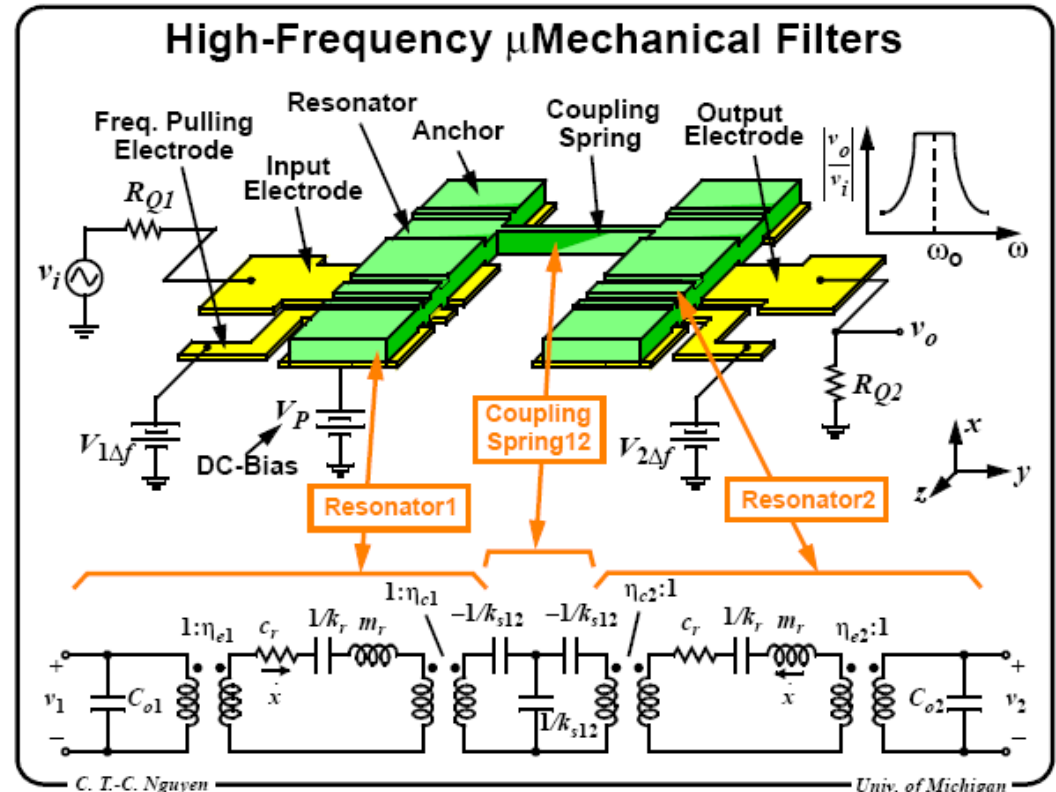

”Mechanical signal processing”

- This unit shows: **Signal processing can be done in the mechanical domain**
- Electrical input signal is converted to force
 - By capacitive input transducer
- Mechanical displacements (vibrations) are induced in x-direction due to the varying force
- The resulting **mechanical signal** is then “processed” in the mechanical domain
 - ”Reject” if outside pass band
 - ”Passed” if inside pass band

"Mechanical signal processing", contd.

- The mechanically processed signal manifests itself as movement of the output transducer
- The movement is converted to electrical energy
 - Output current $i_o = V_d * dC/dt$
- → "micromechanical signal processor"
- The electrical signal can be further processed by succeeding transceiver stages

BP-filter using 2 c-c beam resonators

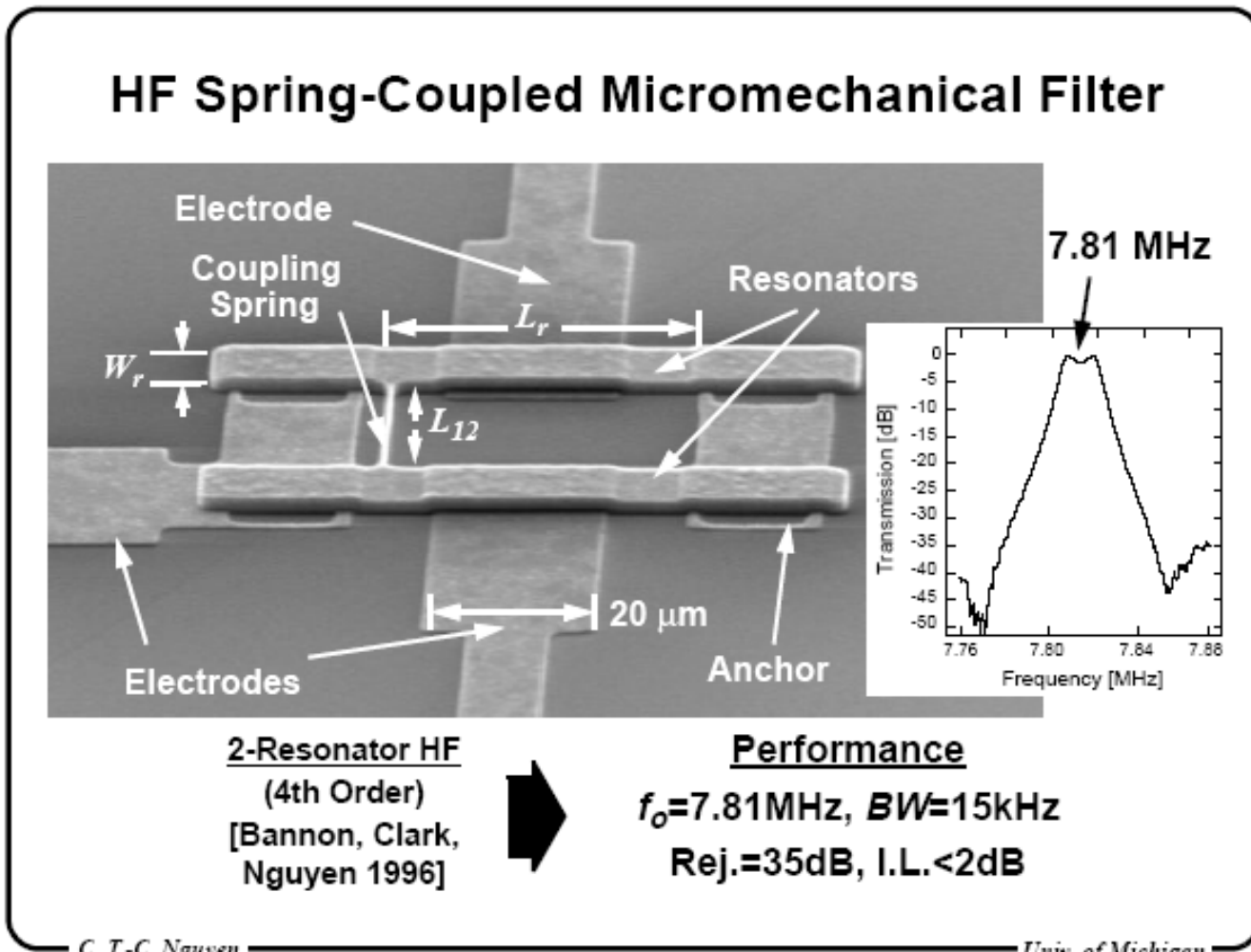

VHF Spring-Coupled Micromechanical Filter

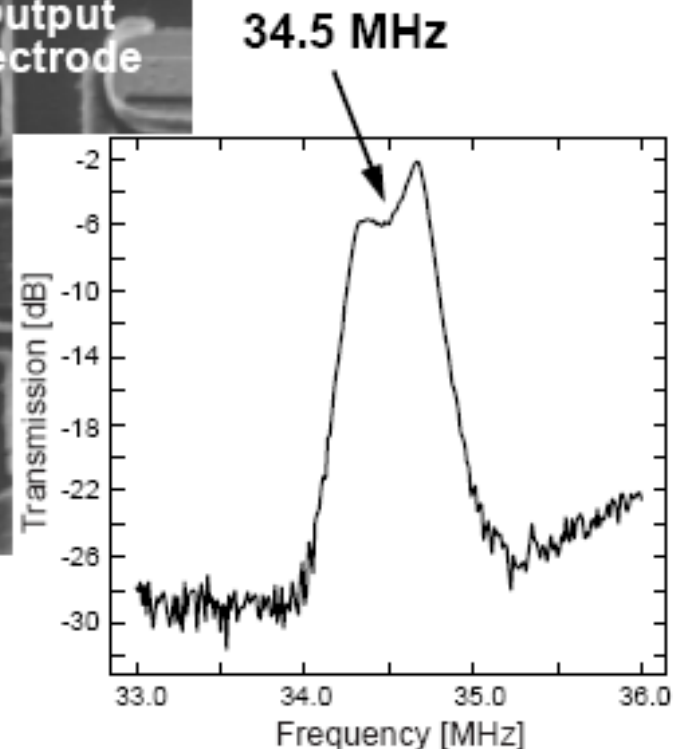
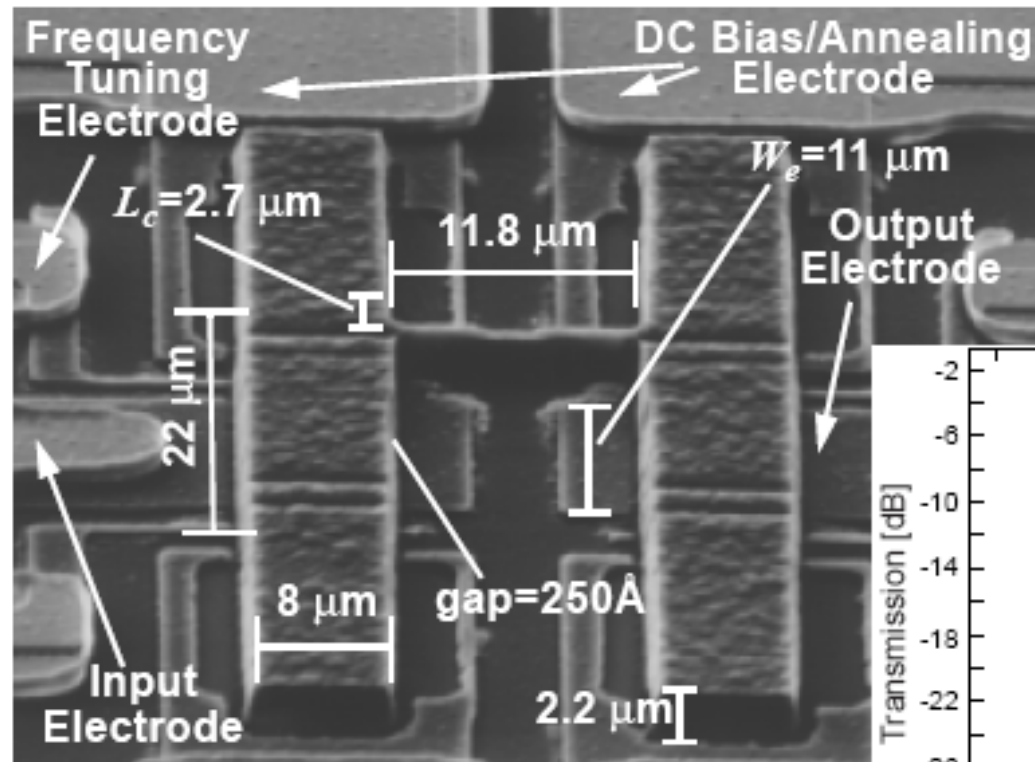

Performance:
 $V_p \sim 15\text{V}$, $R_Q \sim 2\text{k}\Omega$
 $f_o \sim 34.5\text{MHz}$, $BW \sim 1.3\%$
 $\text{Rej.} = 25\text{dB}$, $\text{I.L.} < 6\text{dB}$

[Wong, Ding, Nguyen 1998]

Filter response

- **Frequency separation** depends on the **stiffness of the coupling spring**
 - Soft spring (“compliant”) → close frequencies = narrow pass band
- Increased number of coupled resonators in a linear chain gives
 - Wider pass band
 - **Increased number of passband “ripples”**
 - → the total number of oscillation modes are equal to the number of coupled resonators in the chain

Ideal Spring Coupled Filter

Two Uncoupled Resonators

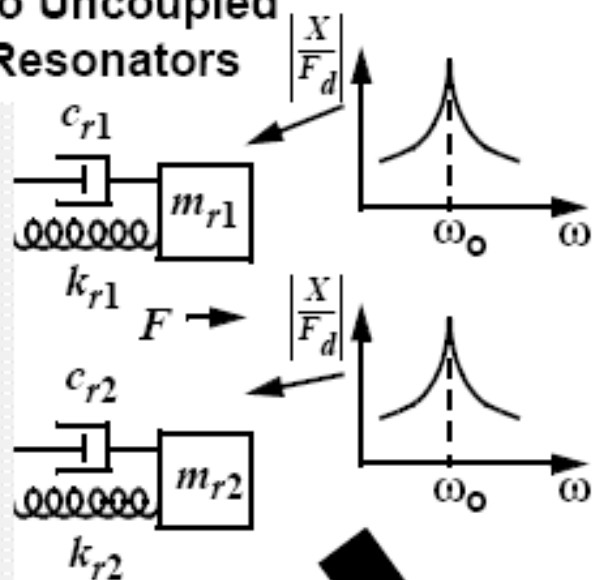

Resonator Stiffness
Coupler Stiffness

$$BW = \left(\frac{f_o}{k_{ij}} \right) \left(\frac{k_{sij}}{k_r} \right)$$

Normalized Coupling Coefficient

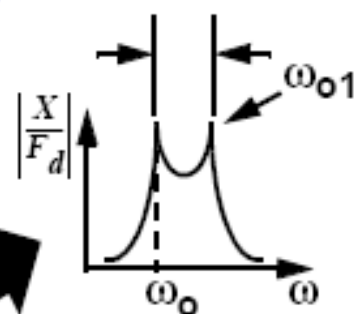

Massless Spring

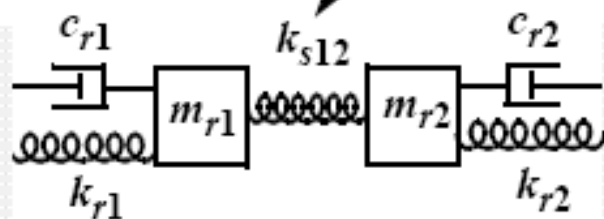

Spring Coupled Resonators

Filter design

- Resonators used in micromechanical filters are normally **identical**
 - Same dimension and resonance frequency
 - Filter centre frequency is f_0
 - (if "massless coupling spring")
- Pass band determined by max distance between node tops
 - Relative position of vibration tops is determined by
 - Coupling spring stiffness k_{sij}
 - Resonator properties (spring constant) k_r
at coupling points

Design, contd.

- At centre frequency f_0 and bandwidth B , spring constants must fulfill

$$B = \left(\frac{f_0}{k_{ij}} \right) \cdot \left(\frac{k_{sij}}{k_r} \right)$$

- k_{ij} = normalized coupling coefficient taken from filter cook books
- Ratio $\left(\frac{k_{sij}}{k_r} \right)$ important, NOT absolute values
- **Theoretical** design procedure A*
- (* can not be implemented in practice)
 - Determine f_0 and k_r Choose k_{sij} for required BW
 - In real life this procedure is **modified** (**procedure B** →)

Design procedures c-c beam filter

- **A.** Design **resonators** first
 - This will give constraints for selecting the stiffness of the coupling beam
 - → but bandwidth B can not be chosen freely!
- or**
- **B.** Design **coupling beam** spring constant first
 - Determine the spring constant the resonator must have for a given BW
 - → this determines the coupling points!

Design procedure A.

- **A1.** Determine resonator geometry for a given frequency and a specific material (ρ)
 - Calculate beam-length (L_r), thickness (h) and gap (d) using equations for f_0 and terminating resistors (R_Q)
 - If filter is symmetric and $Q_{\text{resonator}} \gg Q_{\text{filter}}$, a simplified model for the resistors may be used \rightarrow

For a specific resonator frequency, geometry is determined by:

$$f_0 = const \cdot \sqrt{\frac{E}{\rho}} \cdot \frac{h}{L_r^2} \cdot \left(1 - \left\langle \frac{k_e}{k_m} \right\rangle\right)^{1/2}$$

h, L_r : determined from f_0 – requirement

W_r, W_e : chosen as practical as possible

Added requirement : R_Q

$$R_Q = \frac{k_{re}}{\omega_0 \cdot q_1 \cdot Q_{filter} \cdot \eta_e^2}, \quad Q_{res} \gg Q_{filter}$$

k_{re} : given by resonator dimensions

ω_0 : is given

q_1 : from filter cook book

Q_{filter} : is given

$\eta_e = V_P \cdot \frac{\partial C}{\partial x} \approx \frac{V_P}{d^2}$: only possible variation

V_P : has limitations

d : can be changed! (e, is centre position of beam)

Design-procedure A, contd.

- **A2.** Choose a **realistic width** of the coupling beam W_{s12}
- Length of coupling beam should be a quarter wavelength of the filter centre frequency
 - → Coupling springs are in general transmission lines
 - The filter will not be very sensitive to dimensional variations of the coupling beam if a quarter wavelength
 - Quarter wavelength requirement determines the **length of the coupling beam** L_{s12}

Design procedure A, contd.

- Constraints on width, thickness and length determines the **coupling spring constant**

$$k_{s12}$$

- This limits the possibility to set the bandwidth independently (BW depends on the coupling spring constant)

$$B = \left(\frac{f_0}{k_{12}} \right) \cdot \left(\frac{k_{s12}}{k_{rc}} \right)$$

- An **alternative method for determining the filter-bandwidth** is needed → see design procedure B

Design procedure B

- **B1.** Use **coupling points** on the resonator to determine filter bandwidth
 - BW determined by the ratio $\frac{k_{s12}}{k_{rc}}$
 - k_{rc} is the value of k at the **coupling point!**
 - k_{rc} position dependent, especially of the **speed** at the position
 - k_{rc} **can be selected by choosing a proper coupling point of resonator beam!**
- The dynamic spring constant k_{rc} for a c-c beam is largest nearby the anchors
 - k_{rc} **is larger for smaller speed of coupling point at resonance**

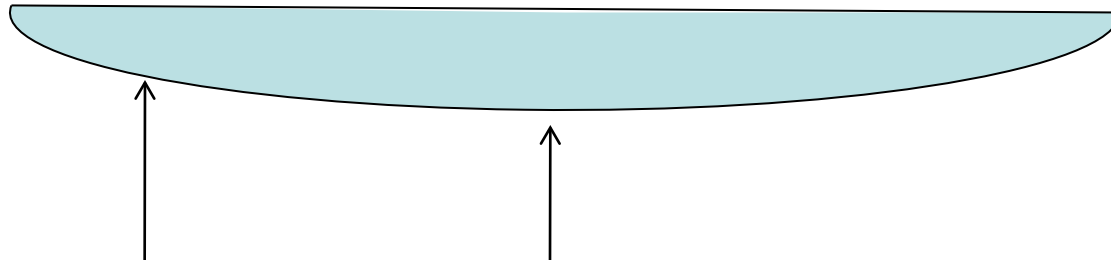

Smaller speed

Max. speed

$$\omega_0 = \text{const} = \sqrt{\frac{k_{eff}}{m_{eff}}}$$

$$m_{eff} = \frac{KE}{\frac{1}{2}v^2}$$

Smaller speed \rightarrow eff. mass higher
 \rightarrow eff. spring stiffness higher

Positioning of coupling beam

- So: filter bandwidth can be found by choosing a value of k_r fulfilling the equation

$$B = \left(\frac{f_0}{k_{ij}} \right) \cdot \left(\frac{k_{sij}}{k_r} \right)$$

- where k_{sij} is **given** by the quarter wavelength requirement

- Choice of **coupling point of resonator beam** influences on the bandwidth of the mechanical filter →

Position of coupling beam

(a) Max. Velocity Coupling: yields large % bandwidth

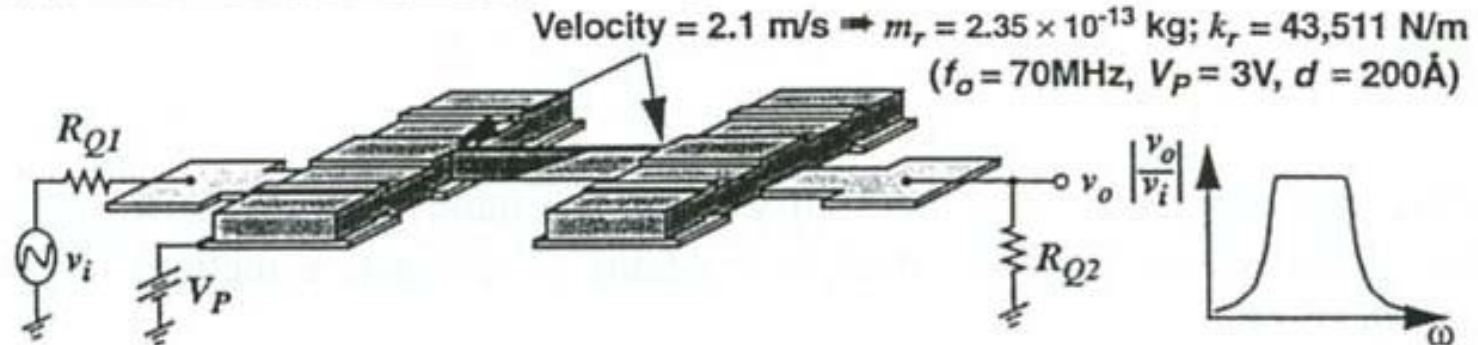

(b) Low Velocity Coupling: allows much smaller % bandwidth

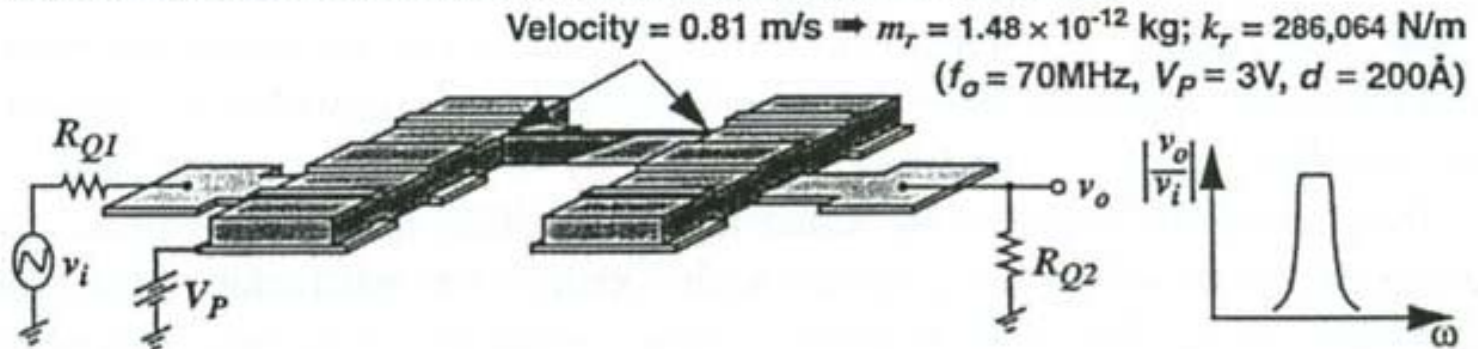

Figure 12.15. Filter schematics showing (a) maximum velocity coupling to yield a large percent bandwidth and (b) low-velocity coupling to yield a smaller percent bandwidth.

Design-procedure, contd.

- **B2.** Generate a complete equivalent circuit for the whole filter structure and verify using a circuit simulator
 - Equivalent circuit for 2-resonator filter →
 - Each resonator is modeled as shown before
 - Coupling beam operates as an acoustic transmission line and is modeled as a T-network of energy storing elements
 - Transformers are placed in-between resonator and coupling beam circuit to model velocity transformations that take place when coupling beam is connected at positions outside the resonator beam centre

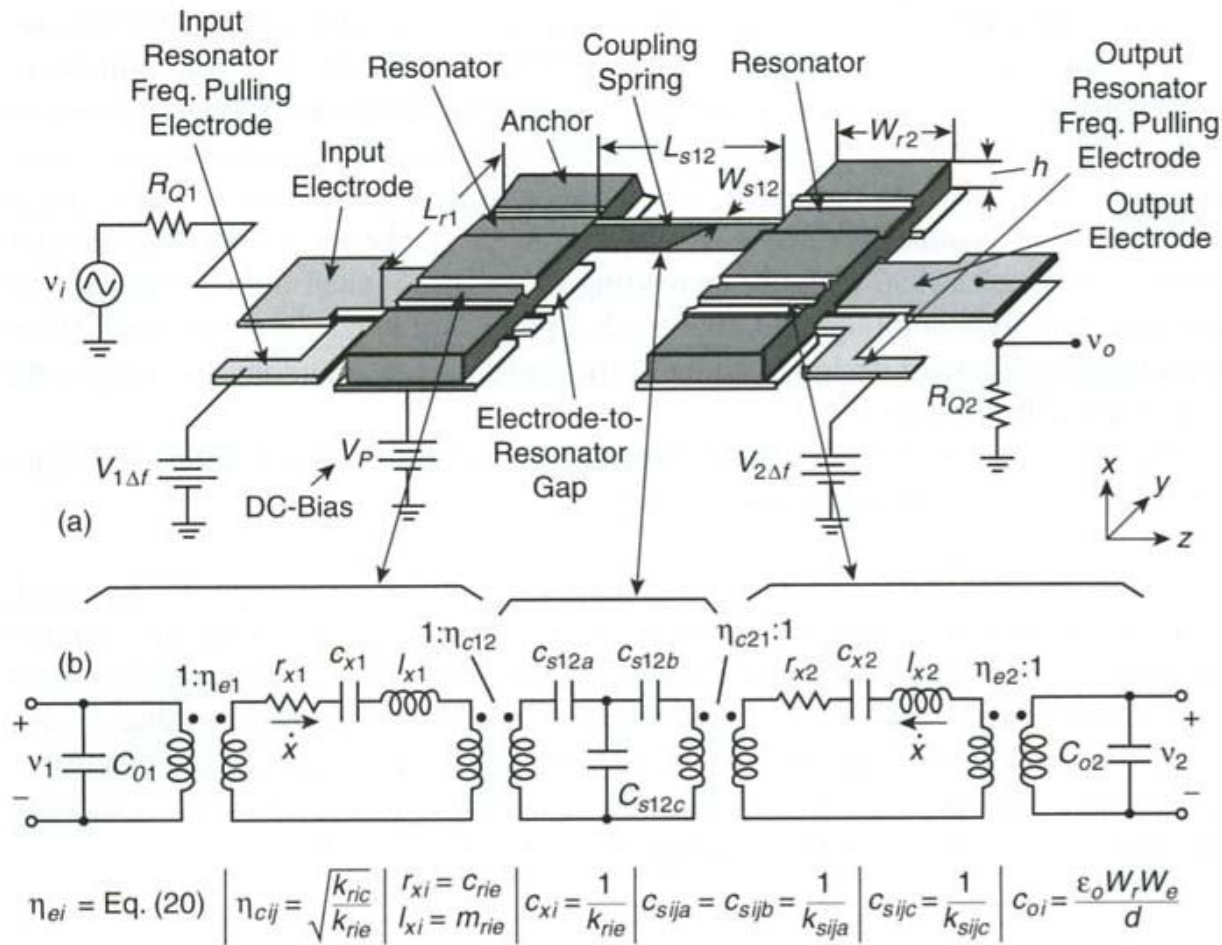

Figure 12.14. (a) Perspective-view schematic of a symmetrical two-resonator VHF μ mechanical filter with typical bias, excitation, and signal conditioning electronics. (b) Electrical equivalent circuit for the filter in (a) along with equations for the elements [18]. Here, m_{rie} , k_{rie} , and c_{rie} denote the mass, stiffness, and damping of resonator i at the beam center location, and η_e and η_c are turns ratios modeling electromechanical coupling at the inputs and mechanical impedance transformations at low-velocity coupling locations. (From reference [18])

HF micromechanical filter

- Coupling position l_c was adjusted to obtain the required bandwidth
- Torsion rotation of coupling beam may also influence the mechanical coupling
 - Effective value of l_c changes
- SEM of symmetric filter : 7.81 MHz
- Resonators consist of phosphor doped poly

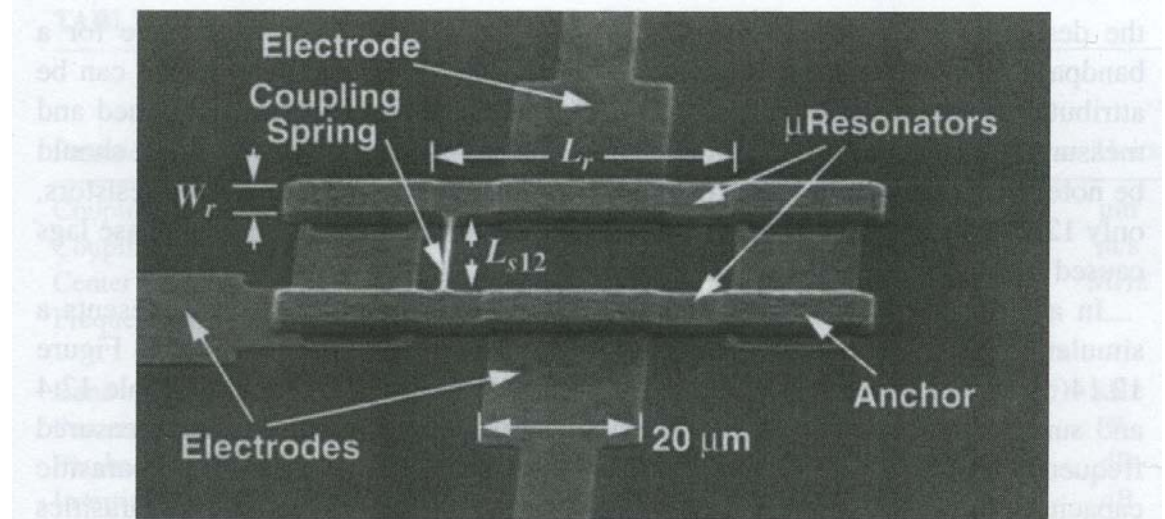

Figure 12.16. SEM of a fabricated 7.81 MHz two-resonator micromechanical filter. (From reference [18])

HF micromechanical filter

Measured and simulated frequency response

BW = 18 kHz, Insertion loss = 1.8 dB, $Q_{\text{filter}} = 435$

- Simulation and experimental results match well in pass band
- Large difference in the transition region to the stop band
 - In a real filter **poles** that are not modeled, are introduced. They improve the filter shape factor, -due to the feed-through capacitance C_p between input and output electrodes (parasitic element). For fully integrated filters this capacitance can be controlled and the position of the poles can be chosen such that they contribute to a optimized filter performance

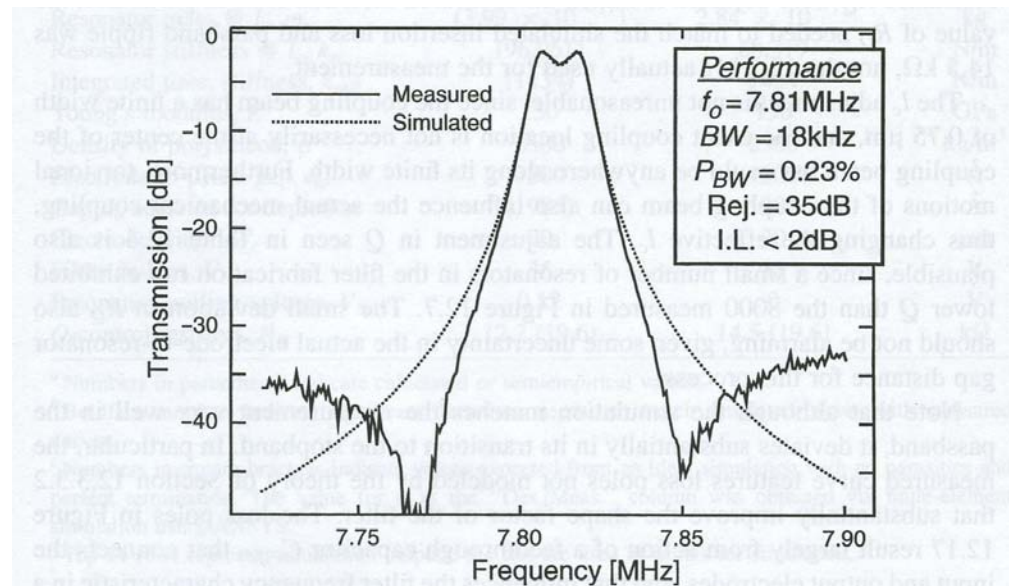
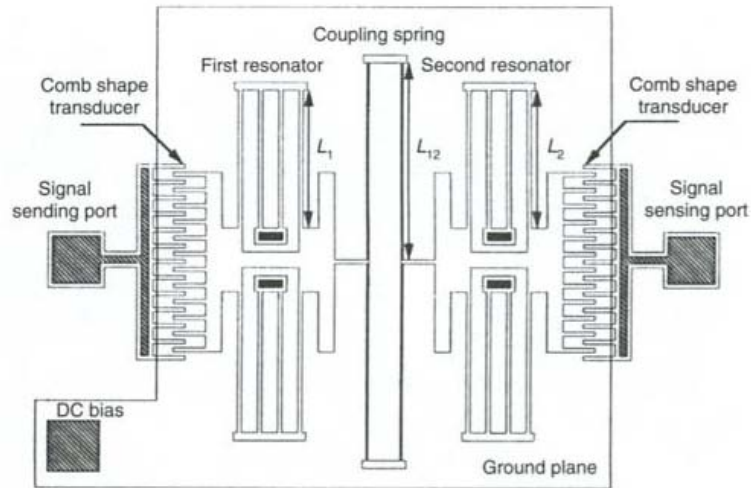

Figure 12.17. Measured spectrum for a terminated 7.81 MHz μ mechanical filter with excessive input/output shunt capacitance. Here, $Q_{\text{filtr}} = 435$. (From reference [18])

Comb structure

- Both series and parallel configurations can be used
- In figure 5.11.b the output currents are added



(a)

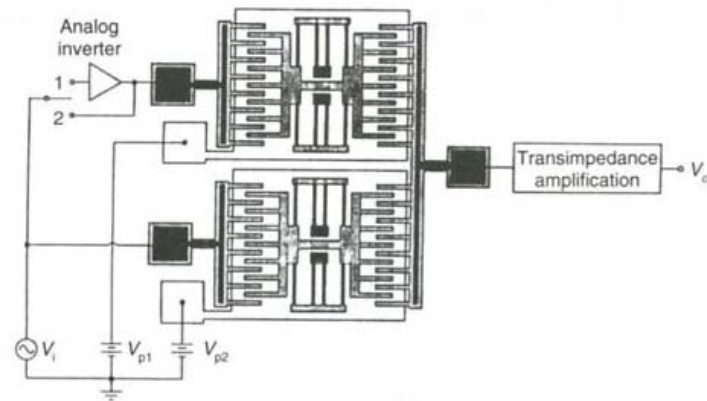

(b)

Figure 5.11 (a) Series and (b) parallel combination of resonators. Reproduced from L. Lin, C.T.-C. Nguyen, R.T. Howe, and A.P. Pisano, 1992, 'Micro electromechanical filters for signal processing', in *IEEE Conference on Micro Electro Mechanical Systems '92, February 4-7 1992*, IEEE, Washington, DC, by permission of IEEE, © 1992 IEEE

Comb-structure, contd.

- Resonators designed for having different resonance frequencies

$$f_2 - f_1 = \frac{f_1}{Q_1}$$

- Model taken from Varadan p. 262-263:
 - Model assumes a massless coupling beam. Possible to ignore the influence of the mass on the filter performance if the coupling beam length is a **quarter wavelength** of the centre frequency
- Formulas inaccurate for high frequencies and small dimensions
 - → Better method: Use advanced simulation tools

Filter implemented using comb structure

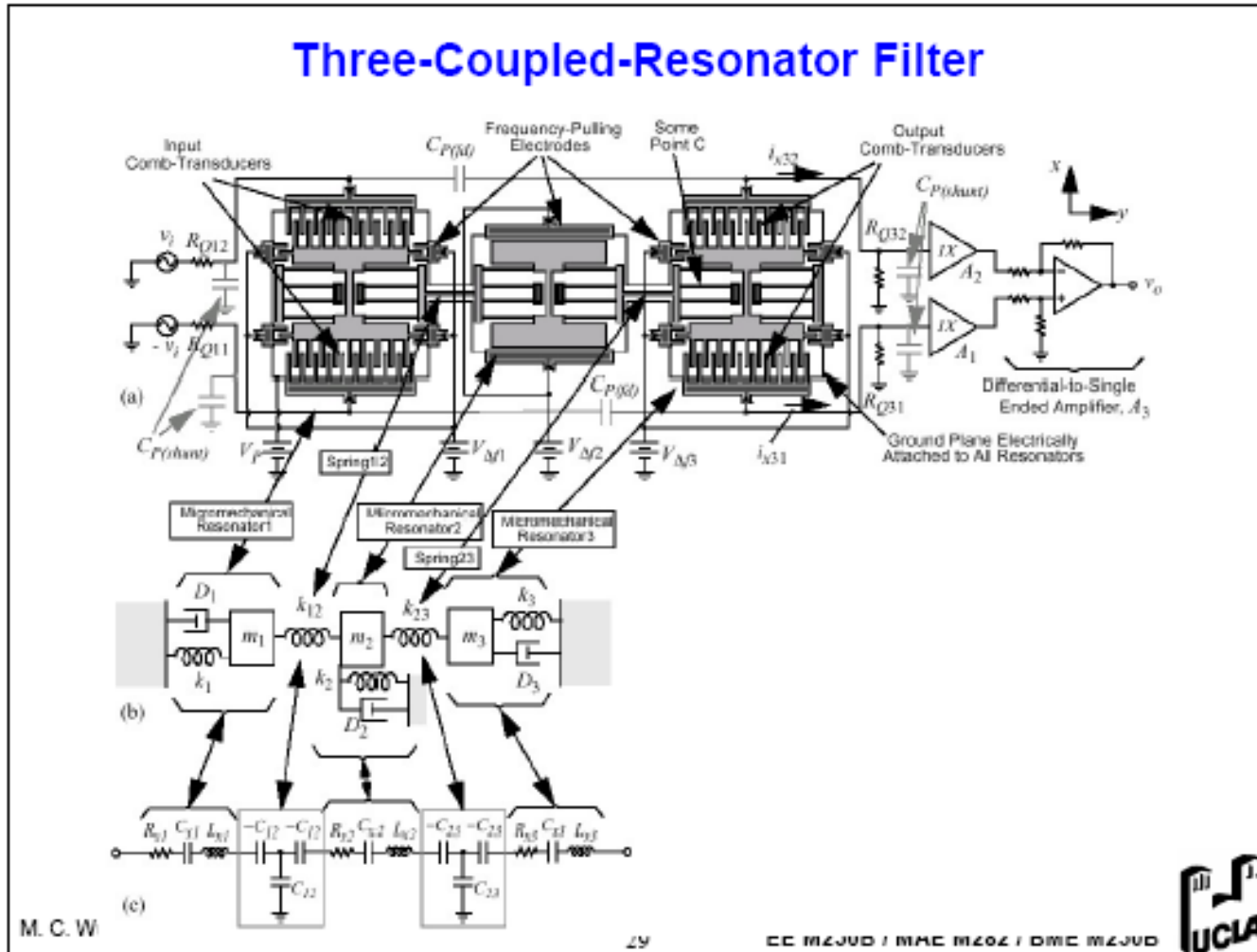

Three-Resonator Spring-Coupled Filter

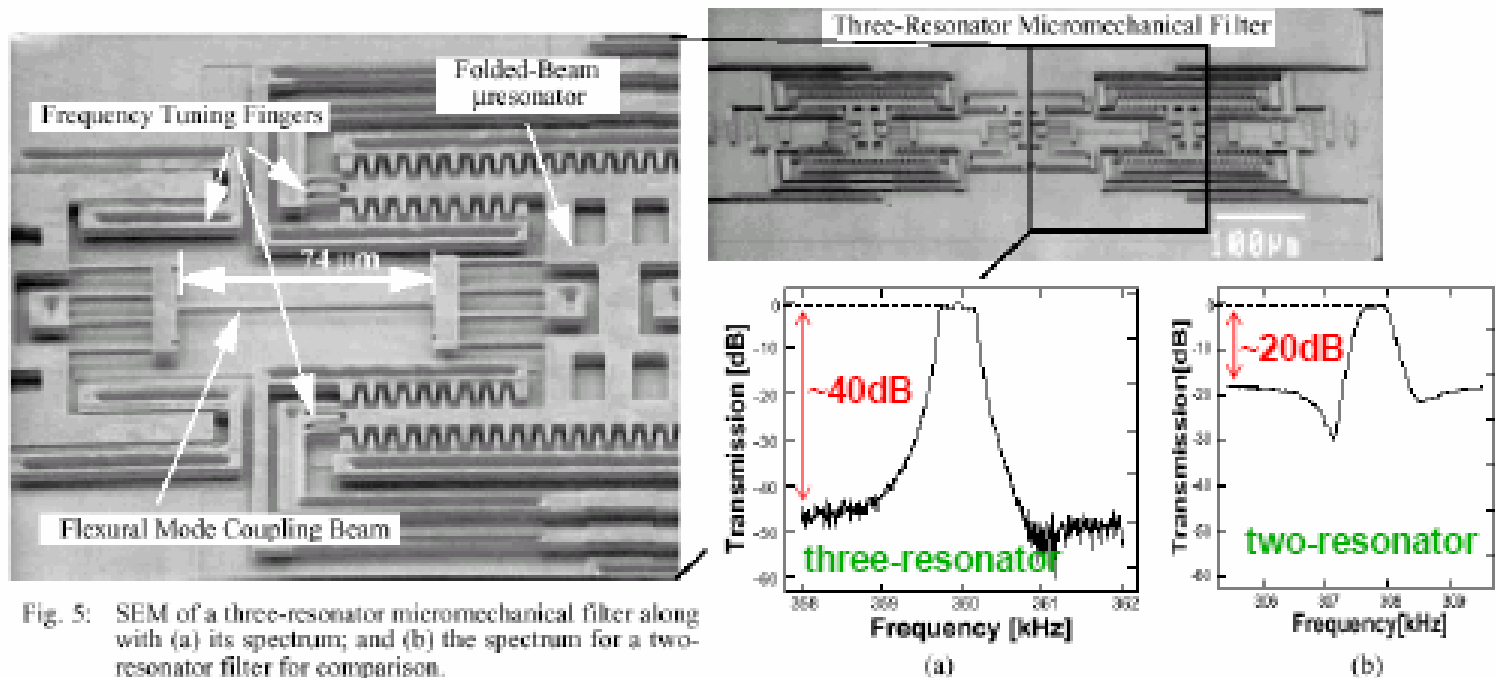
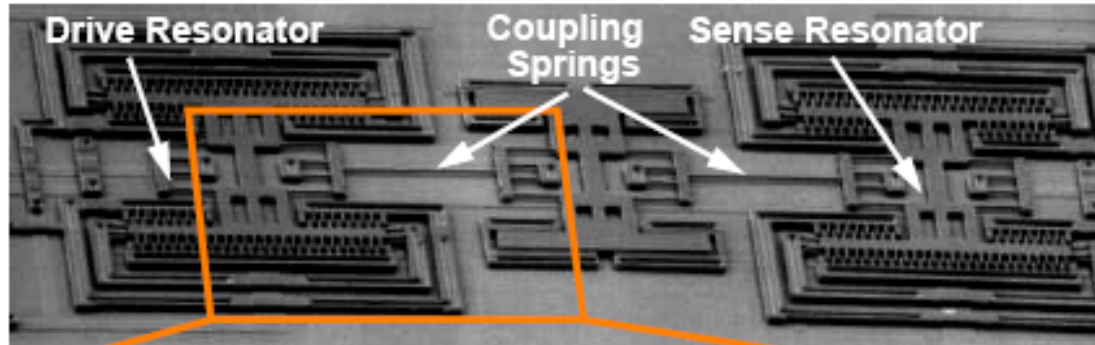
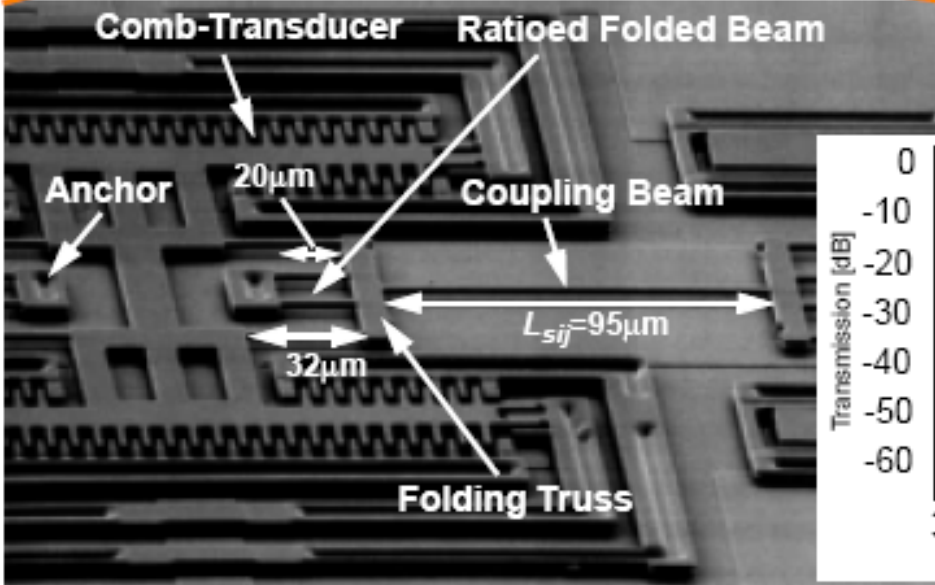

Fig. 5: SEM of a three-resonator micromechanical filter along with (a) its spectrum; and (b) the spectrum for a two-resonator filter for comparison.

High-Order μ Mechanical Filter



3-Resonator MF
(6th Order, 1/5-Velocity Coupled)
 $f_0=340\text{kHz}$
 $BW=403\text{Hz}$
 $\%BW=0.09\%$
 $\text{Stop.R.}=64\text{ dB}$
 $I.L.<0.6\text{ dB}$



[Wang, Nguyen 1997]

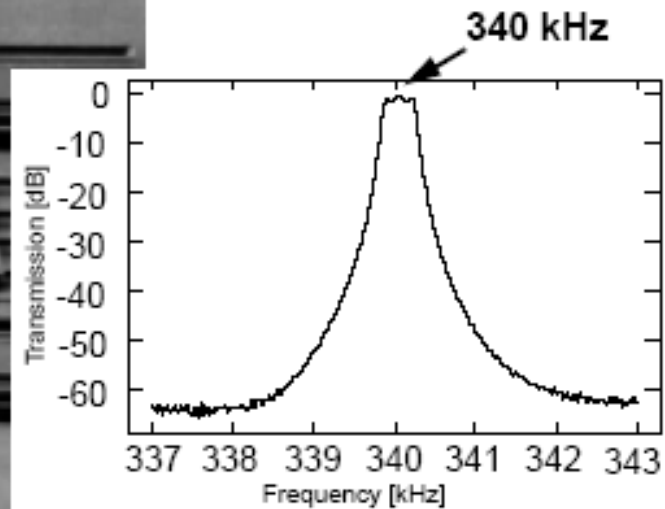

Micromechanical mixer filters

- A 2 c-c beam structure can be modified to be a **mixer**
 - Suppose input **signals** on both on v_e (electrode) and v_b (beam)
- Fig 12.18 Itoh, shows schematic for a symmetric micromechanical mixer-filter-structure →

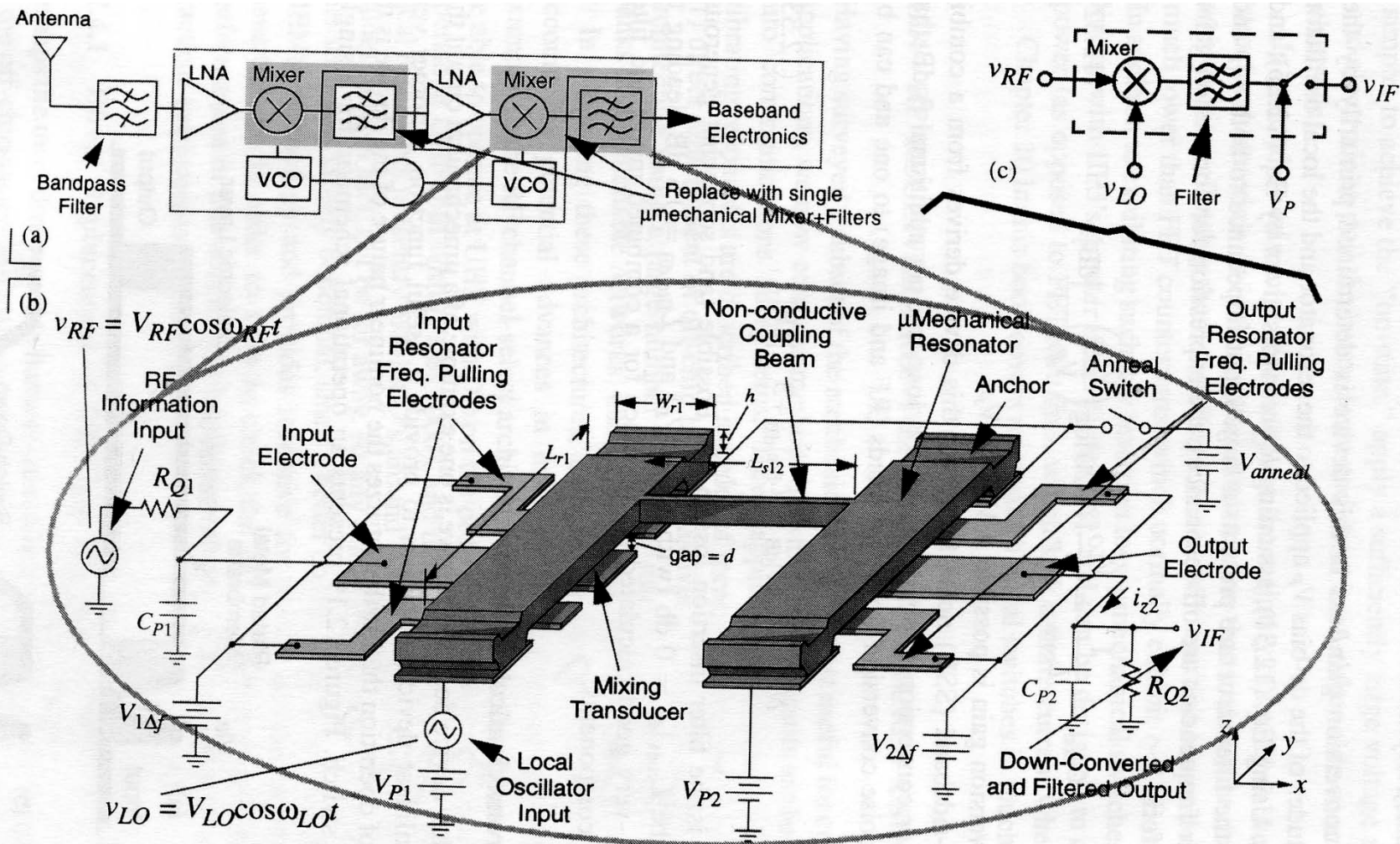

Figure 12.18. (a) Simplified block diagram of a wireless receiver, indicating (with shading) the components replaceable by mixer-filter devices. (b) Schematic diagram of the described μ mechanical mixer-filter, depicting the bias and excitation scheme needed for downconversion. (c) Equivalent block diagram of the mixer-filter scheme.

Mixer

Suppose v_{RF} on electrode

Suppose local oscillator on beam, $v_b = v_{LO}$

Force calculated:

$$F_d = \frac{1}{2}(v_e - v_b)^2 \frac{\partial C}{\partial x} = \frac{1}{2}(v_b^2 - 2v_b v_e + v_e^2) \frac{\partial C}{\partial x}$$

Suppose: $v_e = v_{RF} = V_{RF} \cos \omega_{RF} t$

$$v_b = v_{LO} = V_{LO} \cos \omega_{LO} t$$

$$F_d = \dots - \frac{1}{2} \cdot 2V_{LO} V_{RF} \frac{\partial C}{\partial x} \cdot \cos \omega_{LO} t \cdot \cos \omega_{RF} t$$

[where $2 \cos \omega_1 t \cdot \cos \omega_2 t = \cos(\omega_1 - \omega_2)t + \cos(\omega_1 + \omega_2)t$]

$$F_d = \dots - \frac{1}{2} V_{RF} V_{LO} \frac{\partial C}{\partial x} \cdot \cos(\omega_{RF} - \omega_{LO})t$$

$$F_d = \dots \dots \dots \cdot \cos \omega_{IF} t$$

Micromechanical mixer filters, contd.

- Summary of calculations
 - Start with a non-linear relationship between voltage and force: voltage/force characteristic (square)
 - Linearization: V_p suppresses non-linearity
 - Voltage signals v_{RF} and v_{LO} are mixed down to intermediate frequency (force), ω_{IF} = difference between frequencies!
- Transducer no. 1 can couple the signal into the following resonator
 - If transducer no. 2 is designed as a **micromechanical BP filter** with centre frequency ω_{IF} , we will get an effective **mixer-filter structure**

Micromechanical mixer-filter, contd.

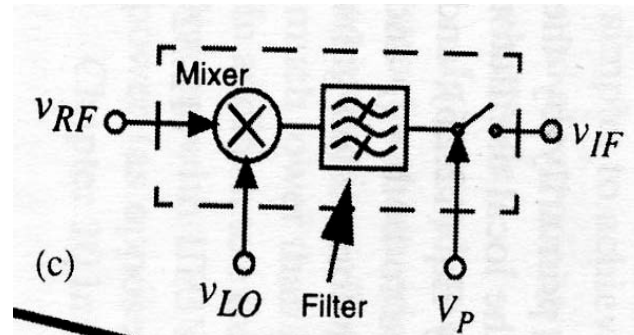

- → Mixer structure is a **functional-block in a RF-system** (future lecture)
 - This is a component that may replace present **mixer + IF-filter** (intermediate-filter)
 - Lower contact-loss between parts and ideally zero DC power consumption
 - A [non-conducting coupling beam](#) is used for isolating the IF-port (e.g. 2. beam) from LO (local oscillator)