

Lecture 6.3

Stereo processing

Trym Vegard Haavardsholm

Stereo geometry

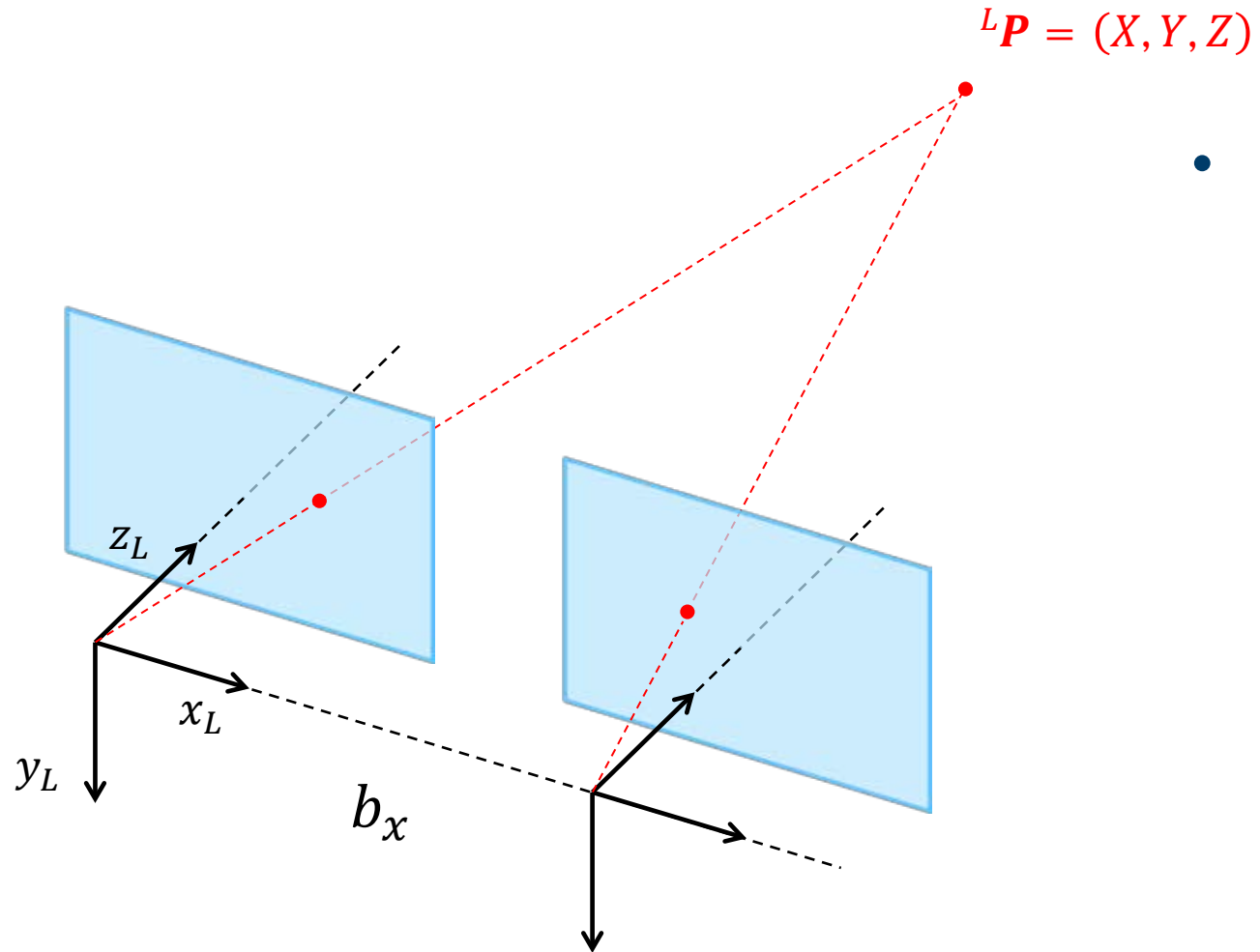

- Parallel identical cameras
 - Translated along x-axis

Stereo geometry

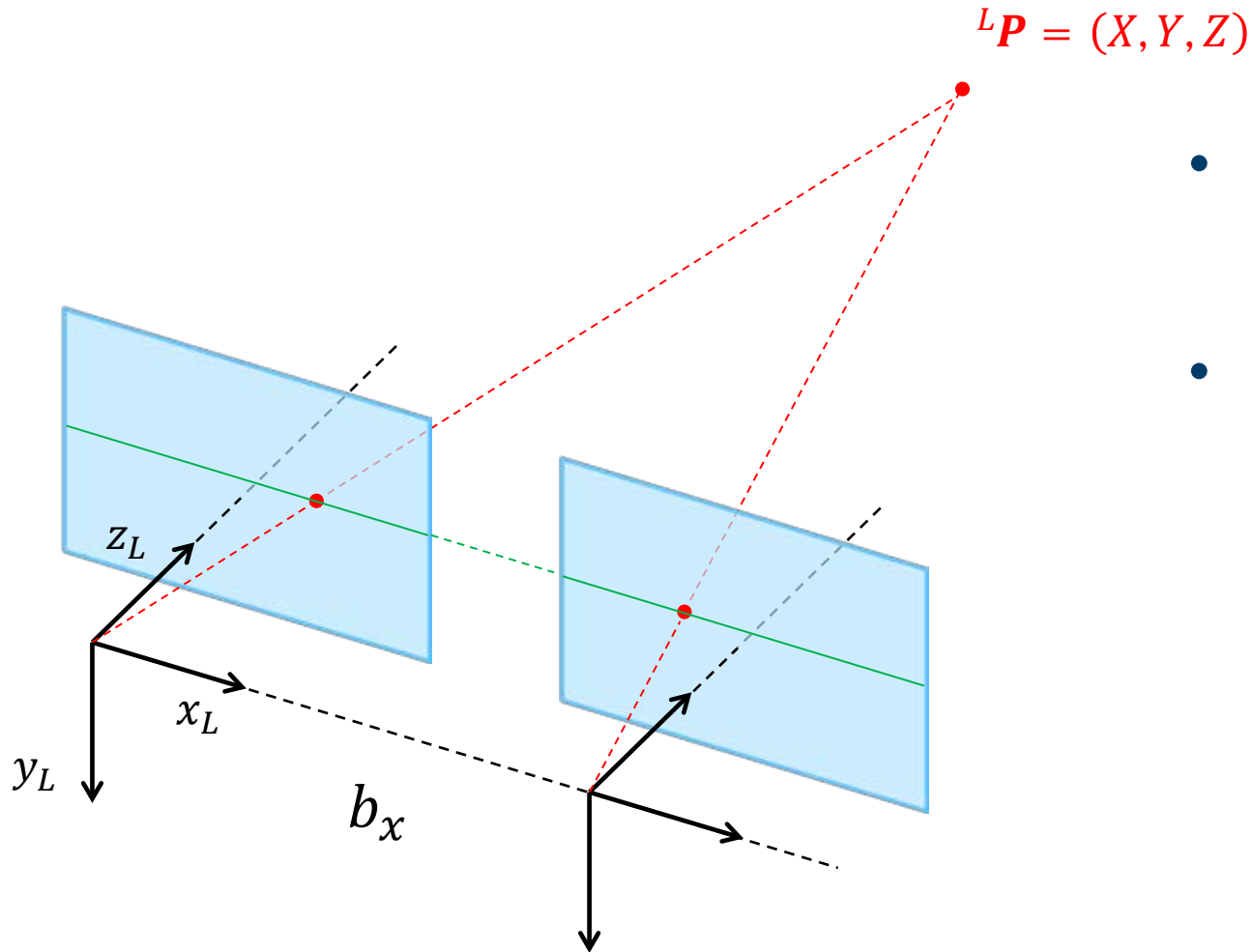

- Parallel identical cameras
 - Translated along x-axis
- Horizontal epipolar lines
 - Corresponding points lie along the same row in the two images

Stereo geometry

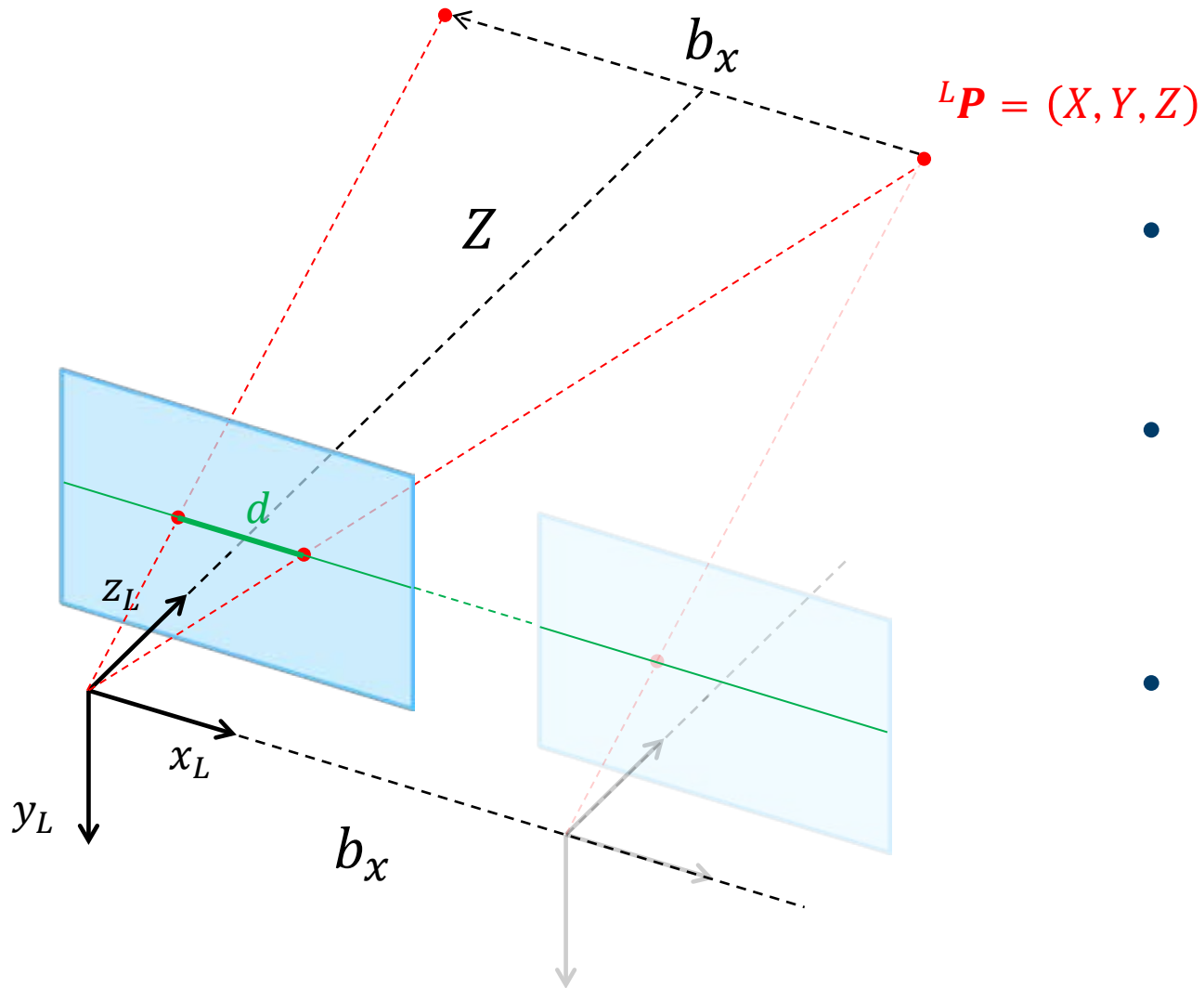

- Parallel identical cameras
 - Translated along x -axis
- Horizontal epipolar lines
 - Corresponding points lie along the same row in the two images
- Depth from disparity

$$Z = f \frac{\text{Baseline } b_x}{\text{Disparity } d}$$

Stereo geometry

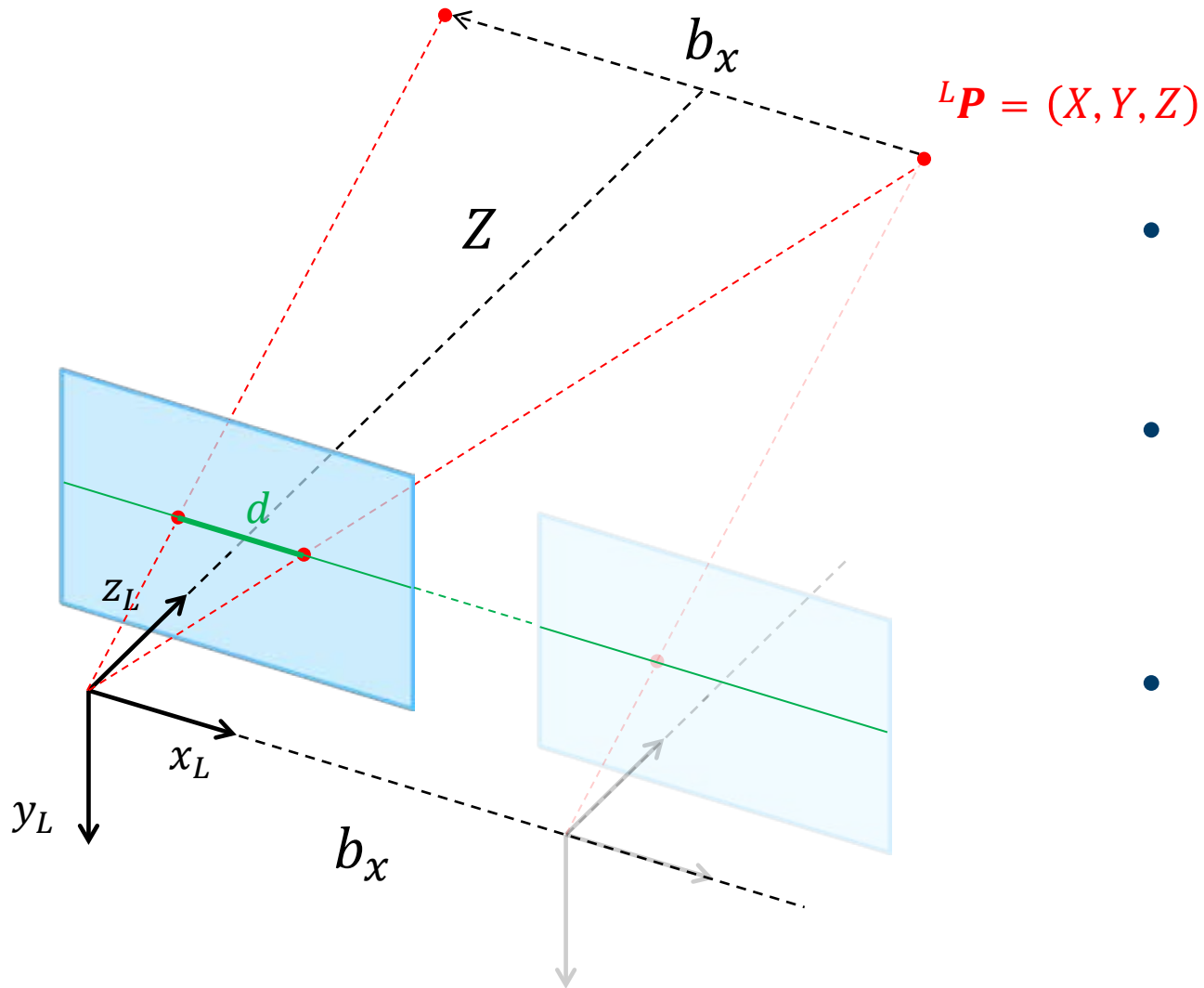

- Parallel identical cameras
 - Translated along x-axis
- Horizontal epipolar lines
 - Corresponding points lie along the same row in the two images
- 3D from disparity

$$Z = f \frac{\text{Baseline } b_x}{\text{Disparity } d} \quad X = x_L \frac{b_x}{d} \quad Y = y_L \frac{b_x}{d}$$

Stereo processing

- Sparse stereo
 - Extract keypoints
 - Match keypoints along the same row
 - Compute 3D from disparity



Sparse stereo matching

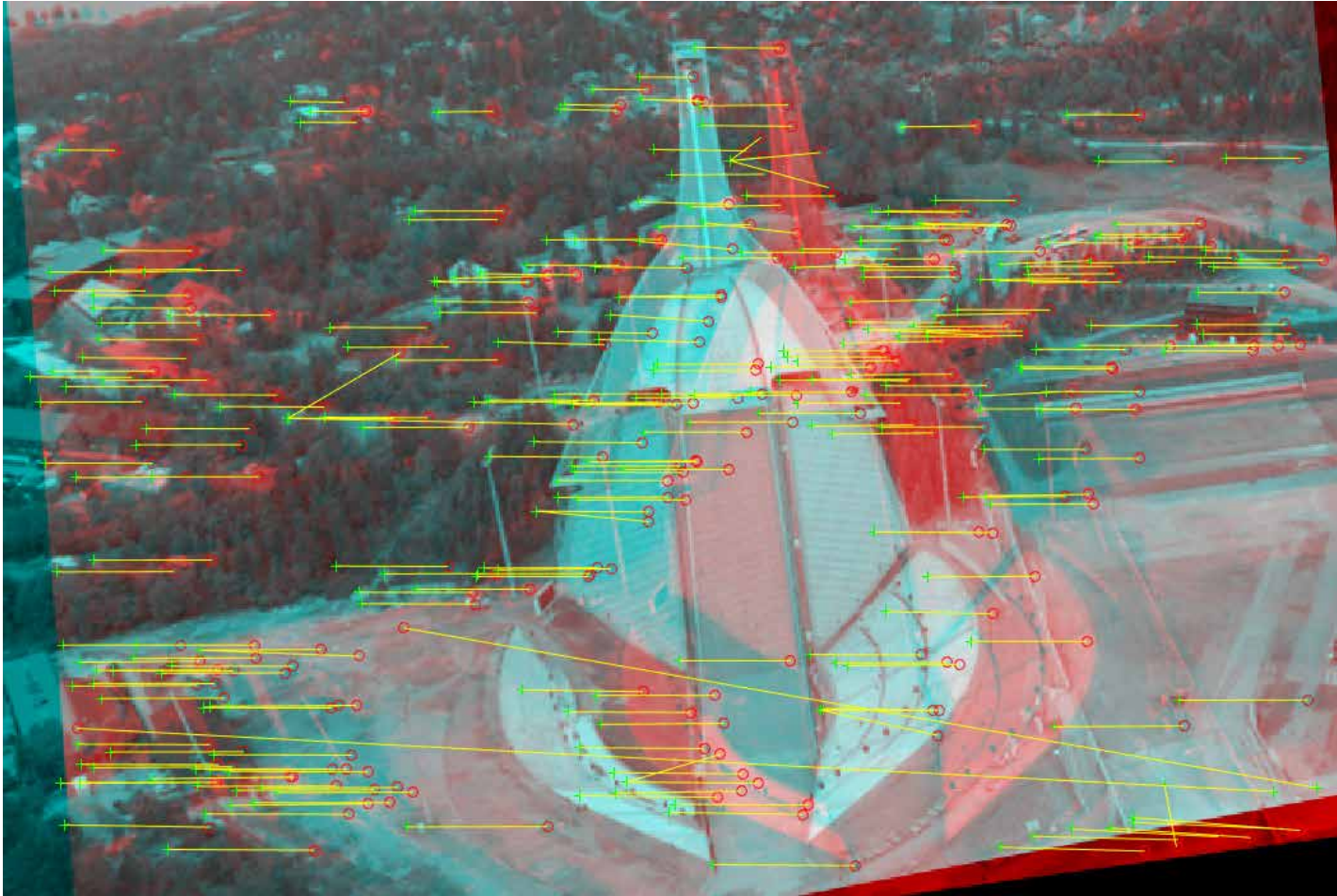

Example

- Putative matches

Sparse stereo matching

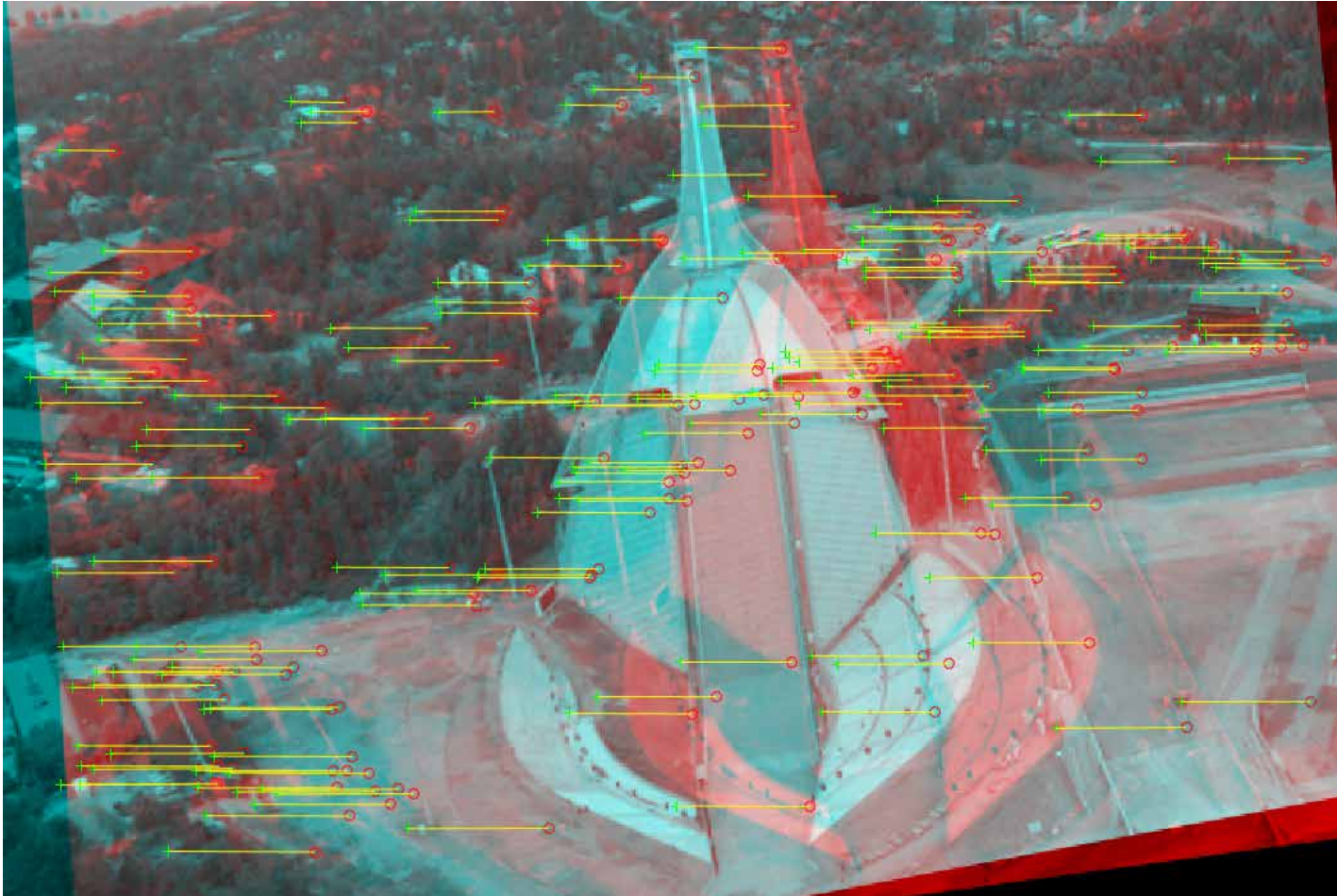

Example

- Matches consistent with epipolar line
- Length of yellow lines corresponds to disparity

Sparse stereo matching

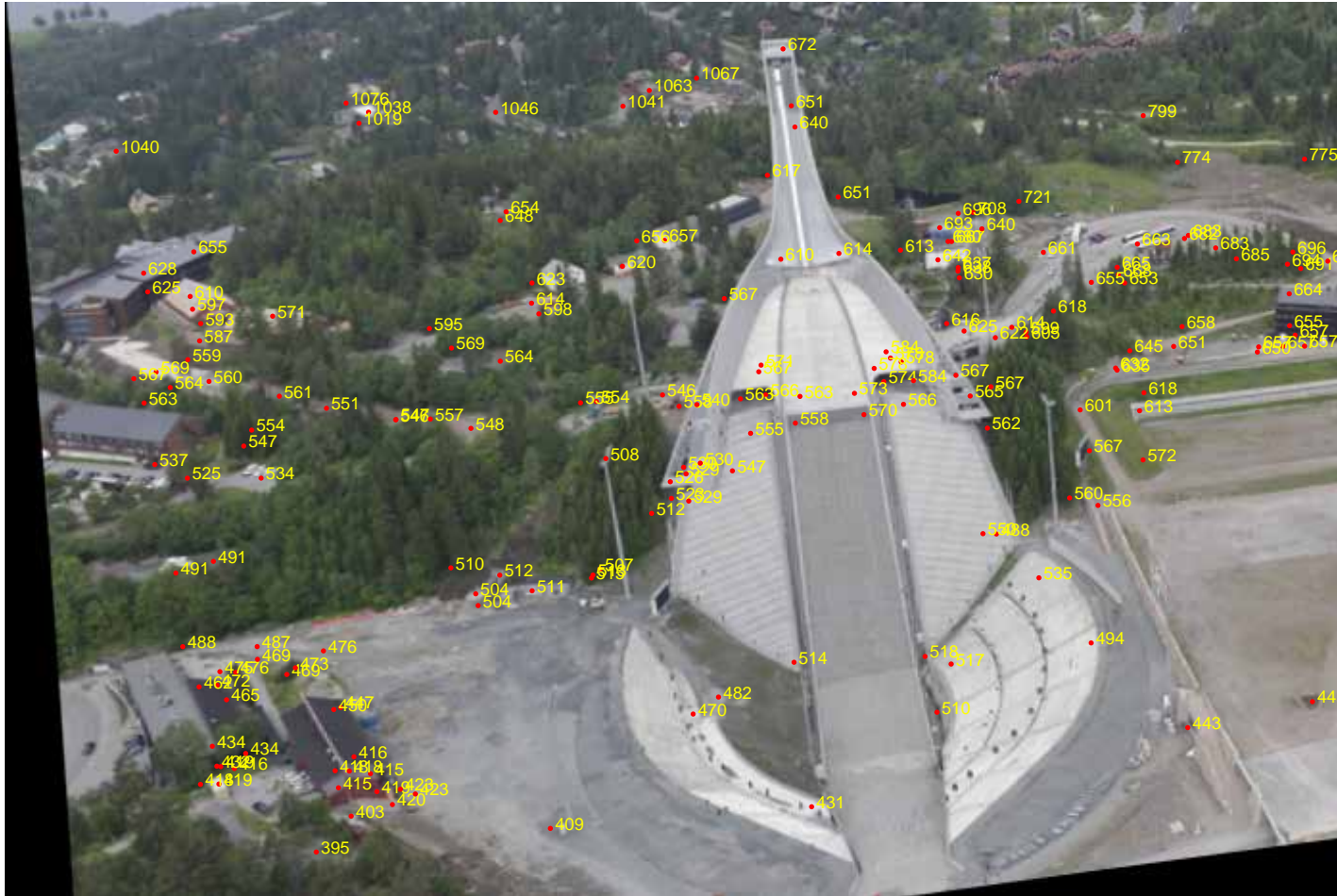

Example

- Depth in meters for each matched point
- Computed directly from disparity

Sparse stereo matching

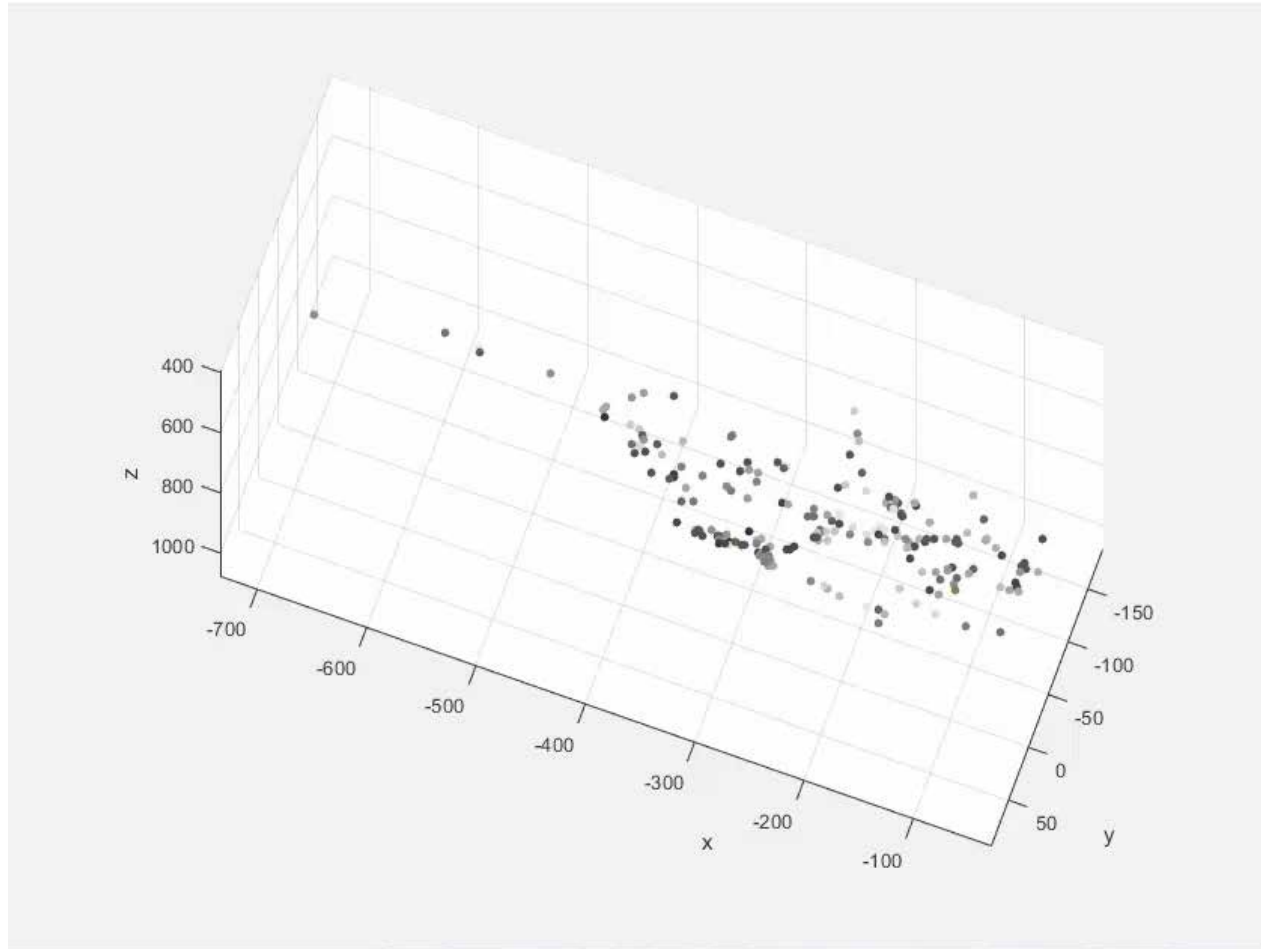

Example

- Sparse 3D point cloud
- Each point has two descriptors
 - Map for pose estimation with PnP!

Stereo processing

- Sparse stereo
 - Extract keypoints
 - Match keypoints along the same row
 - Compute 3D from disparity
- Dense stereo
 - Try to match all pixels along rows
 - Compute disparity image by finding the best disparity for each pixel
 - Refine and clean disparity image
 - Compute dense 3D point cloud or surface from disparity

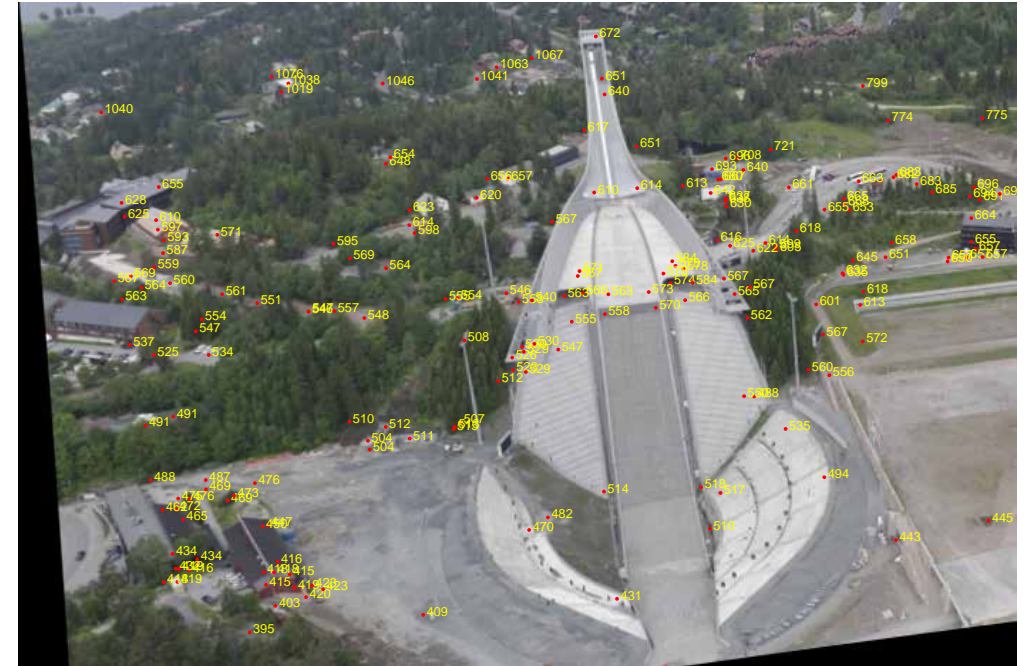

Dense stereo matching



- For a patch in the left image
 - Compare with patches along the same row in the right image

Dense stereo matching



- For a patch in the left image
 - Compare with patches along the same row in the right image

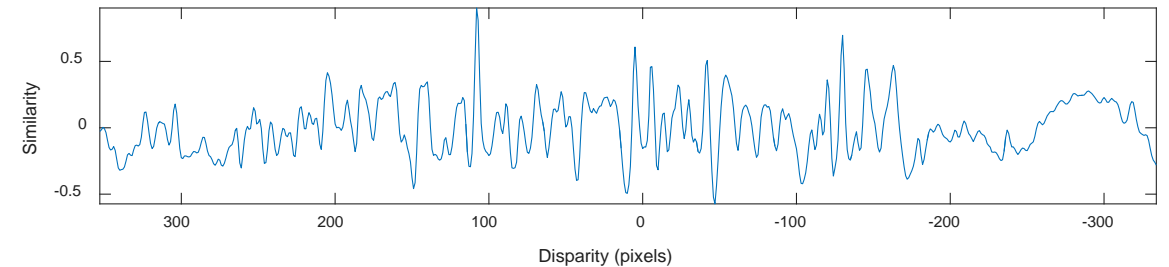

Dense stereo matching



- For a patch in the left image
 - Compare with patches along the same row in the right image
 - Select patch with highest score

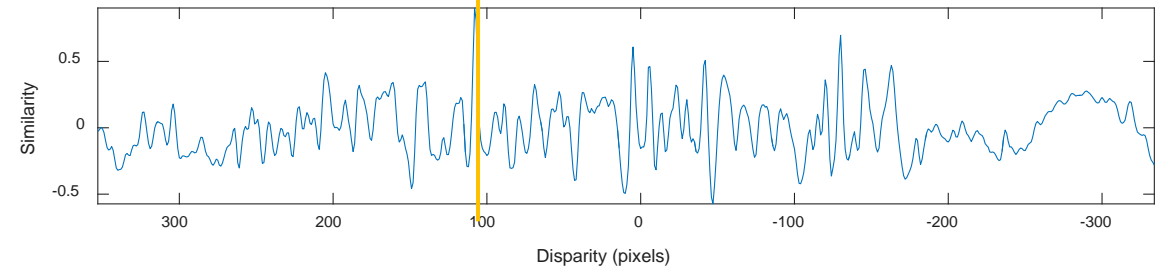

Dense stereo matching



- For a patch in the left image
 - Compare with patches along the same row in the right image
 - Select patch with highest score
- Repeat for all pixels in the left image

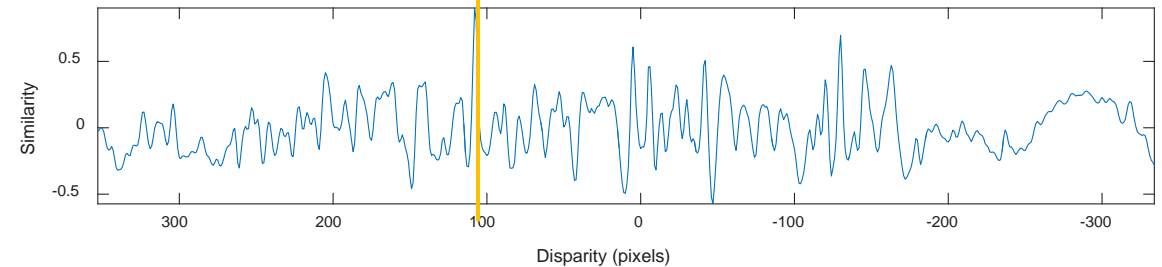

Dense stereo matching



- Computational cost
– $O(DW^2N^2)$

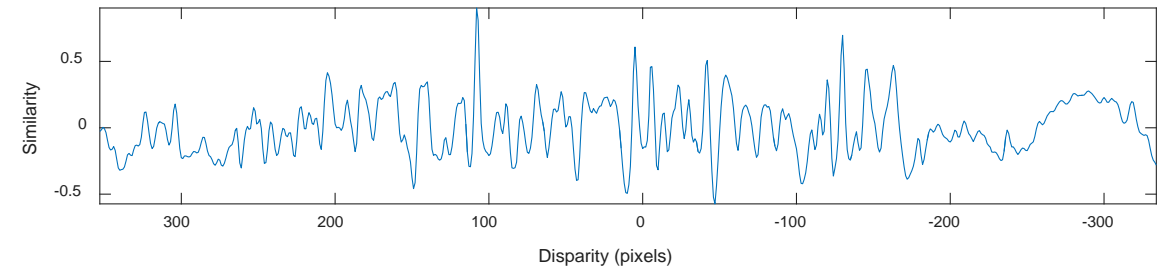

Dense stereo matching

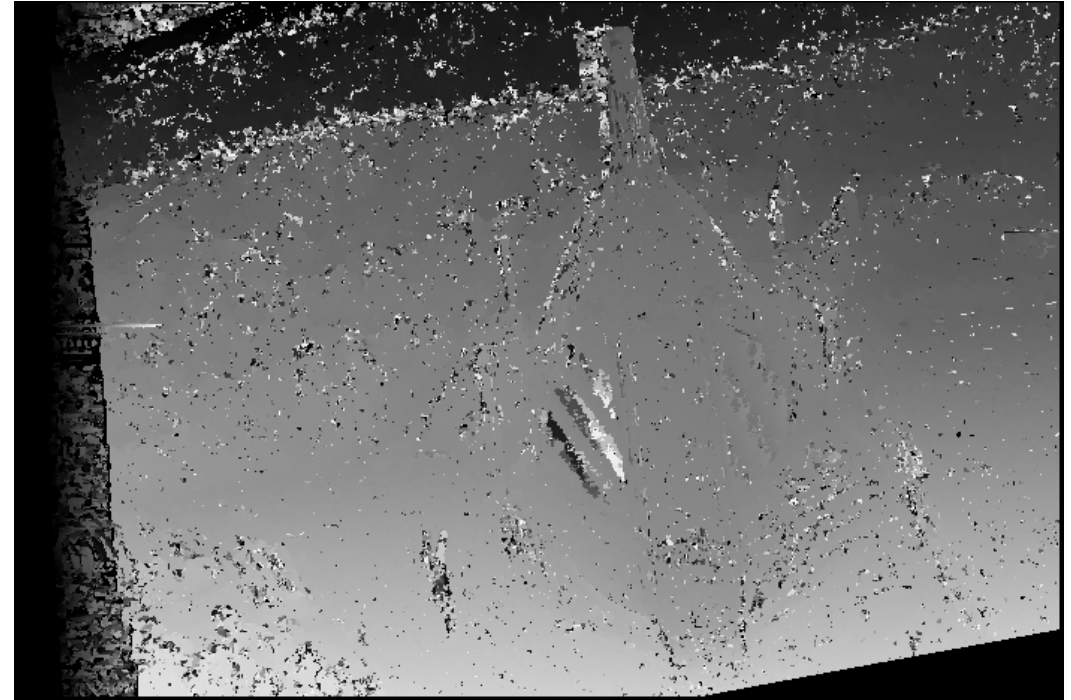

- Size of window
 - Small: More difficult to match, noisy

Dense stereo matching

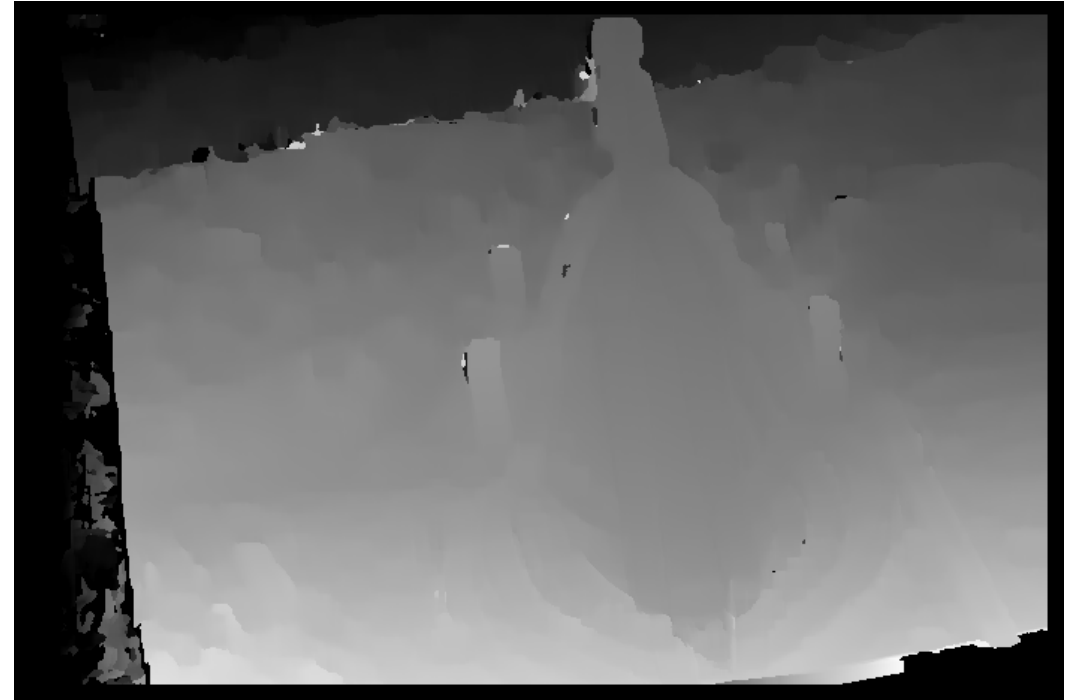

- Size of window
 - Small: More difficult to match, noisy
 - Large: Loss of detail, smooth, slow

Dense stereo matching



- Restrict disparity range
 - Less computation
 - Less memory
 - Less matching errors

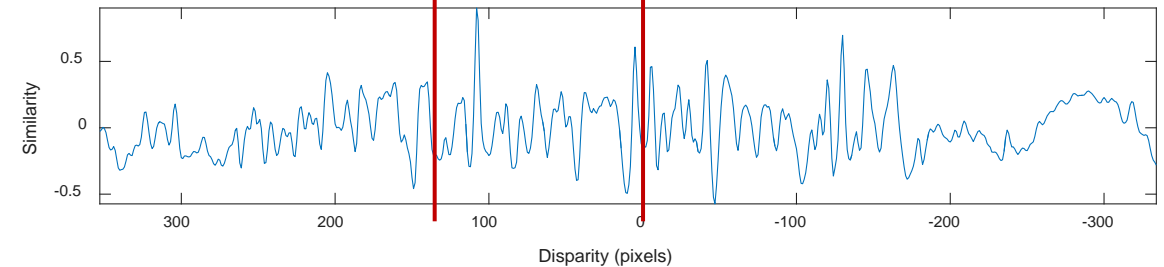

Dense stereo matching



- Restrict disparity range
 - Less computation
 - Less memory
 - Less matching errors

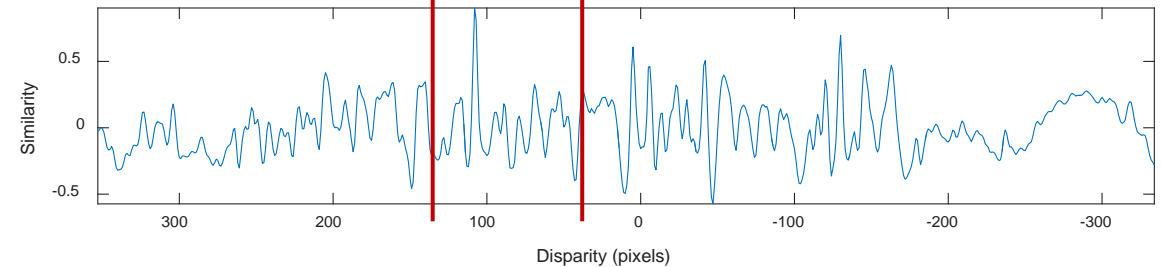

Disparity Space Image (DSI)



- The element $D(u, v, d)$ is the similarity between the support regions centered at (u_L, v_L) in the left image and $(u_L - d, v_L)$ in the right image

Disparity Space Image (DSI)

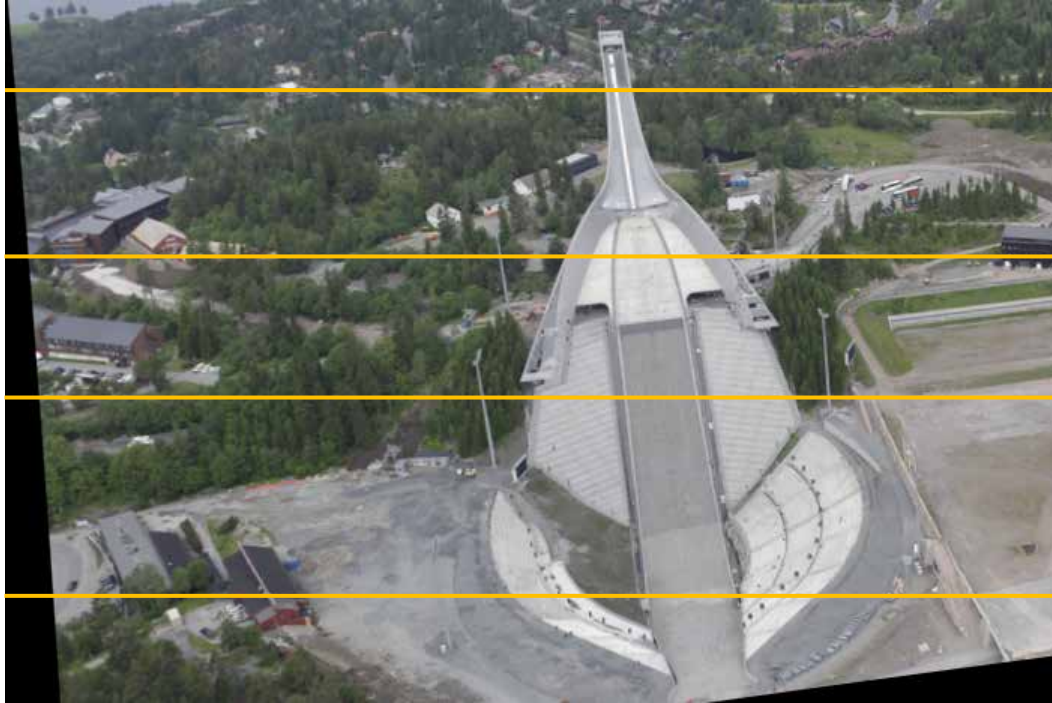

- The element $D(u, v, d)$ is the similarity between the support regions centered at (u_L, v_L) in the left image and $(u_L - d, v_L)$ in the right image

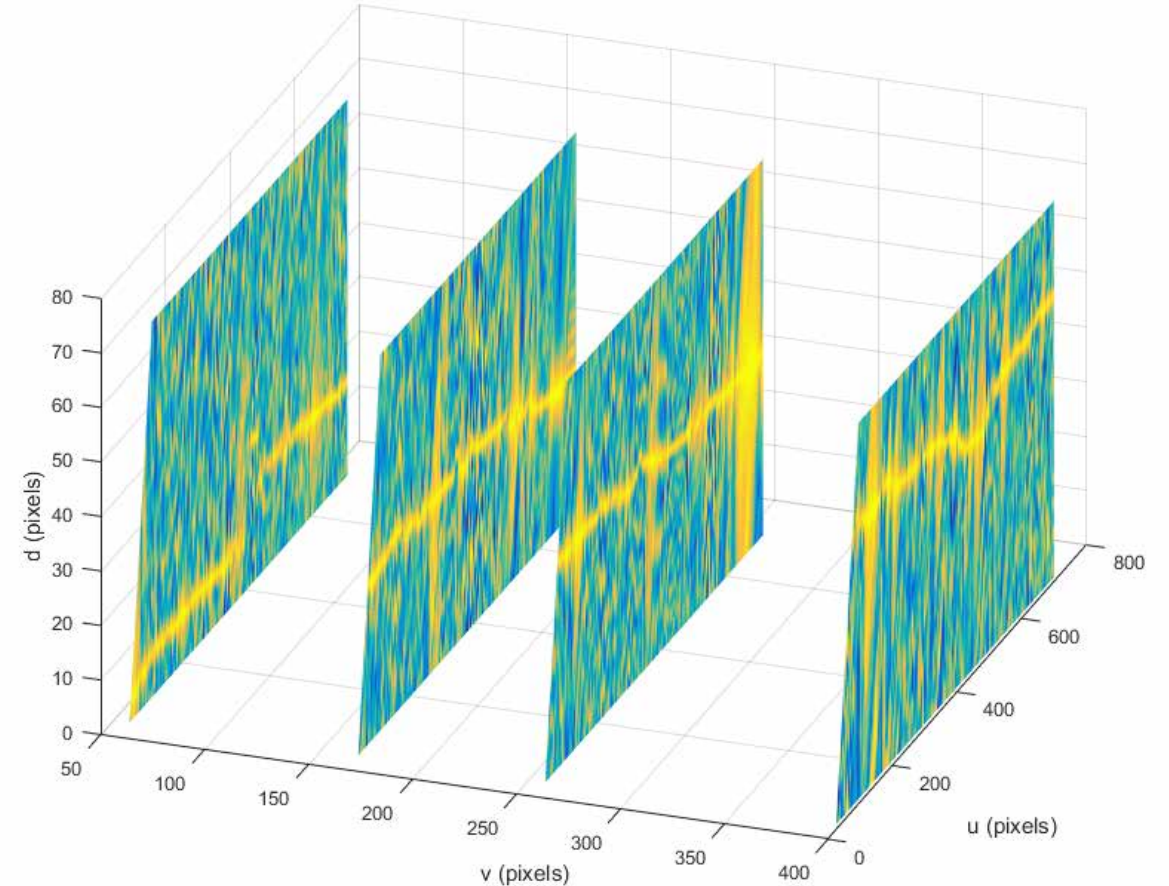

Stereo matching failures

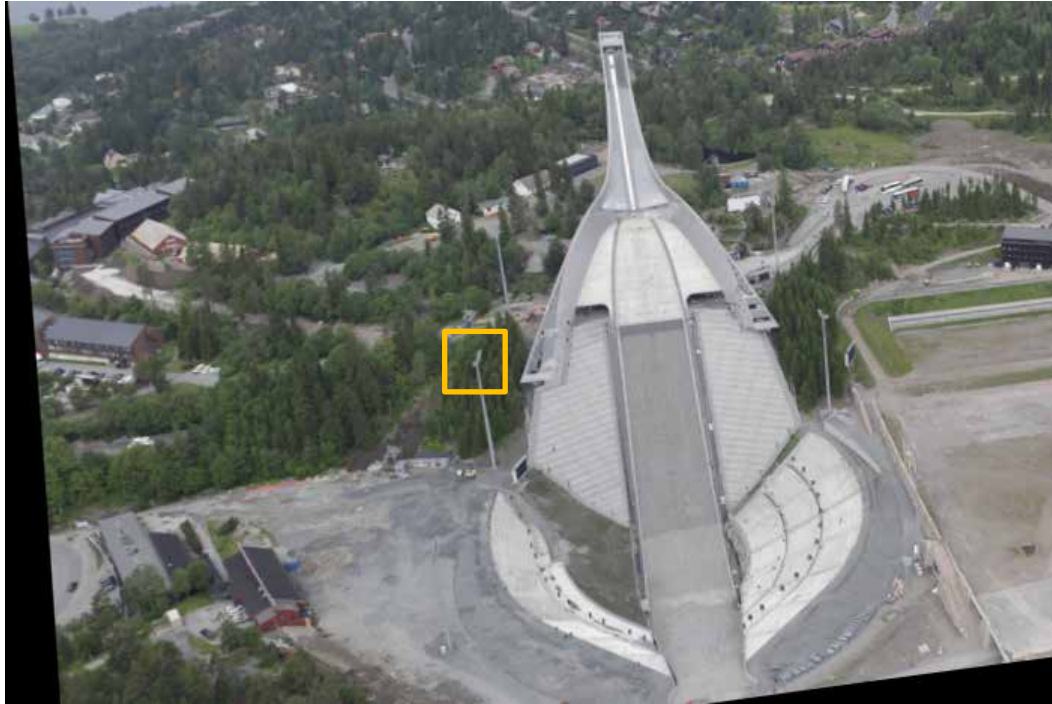

- Single strong unambiguous peak

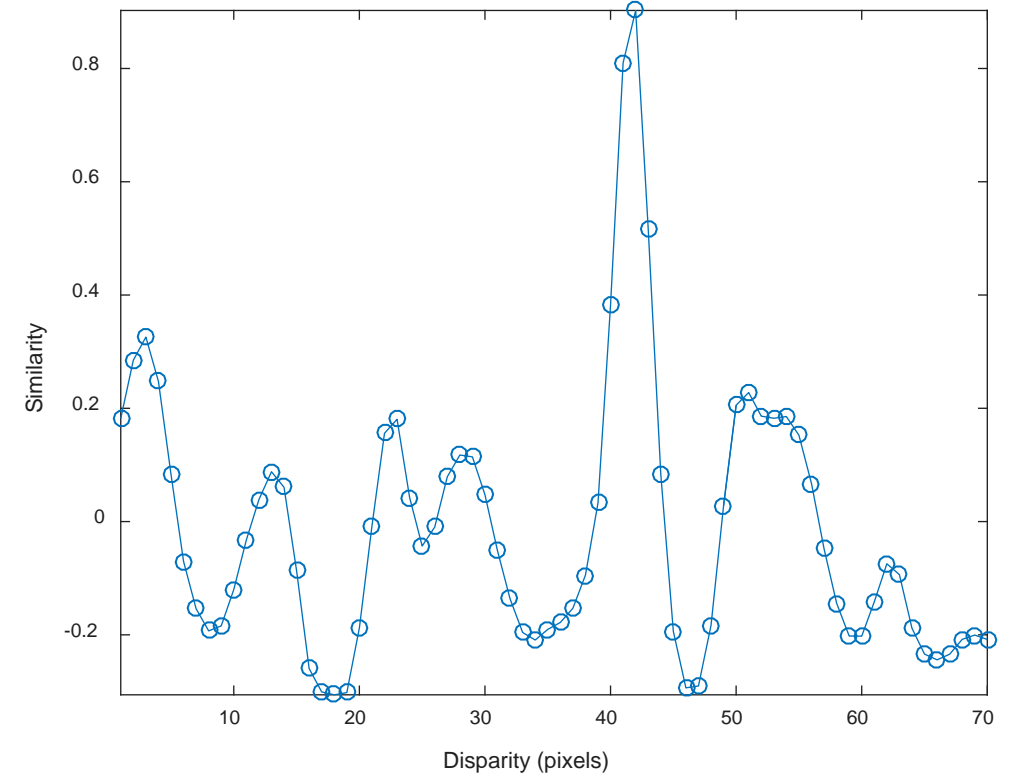

Stereo matching failures



- Several ambiguous peaks
 - Which is the correct peak?
 - Repeating patterns
 - Detect with ratio test

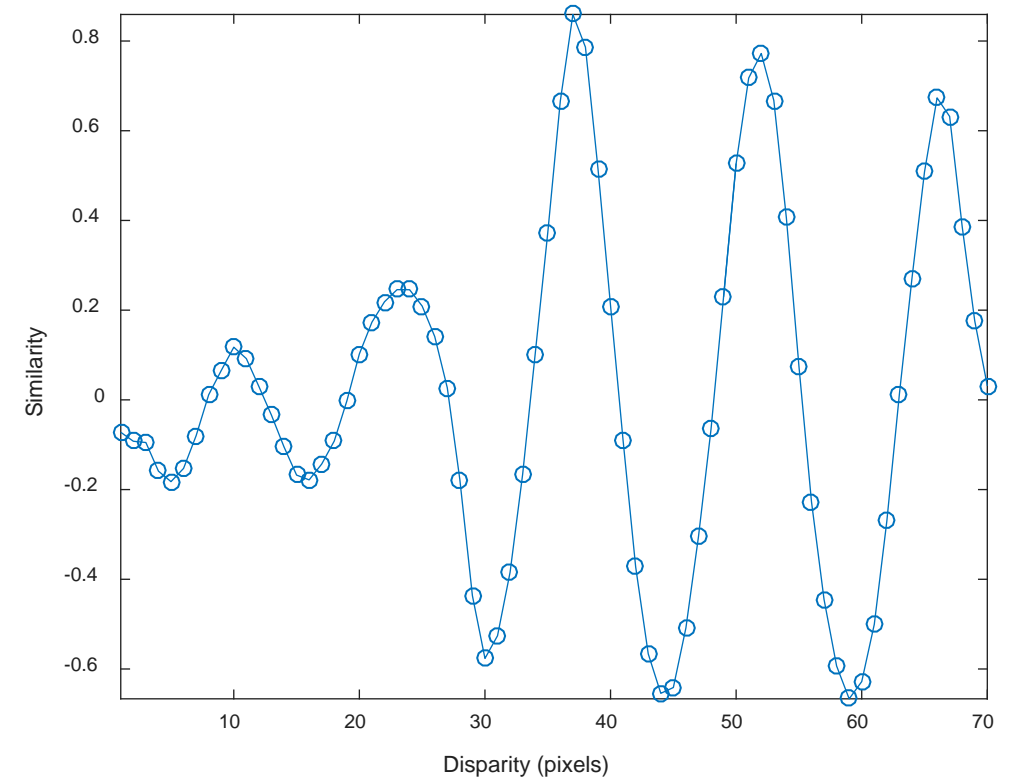

Stereo matching failures



- A weak peak
 - Often occlusion, parallax

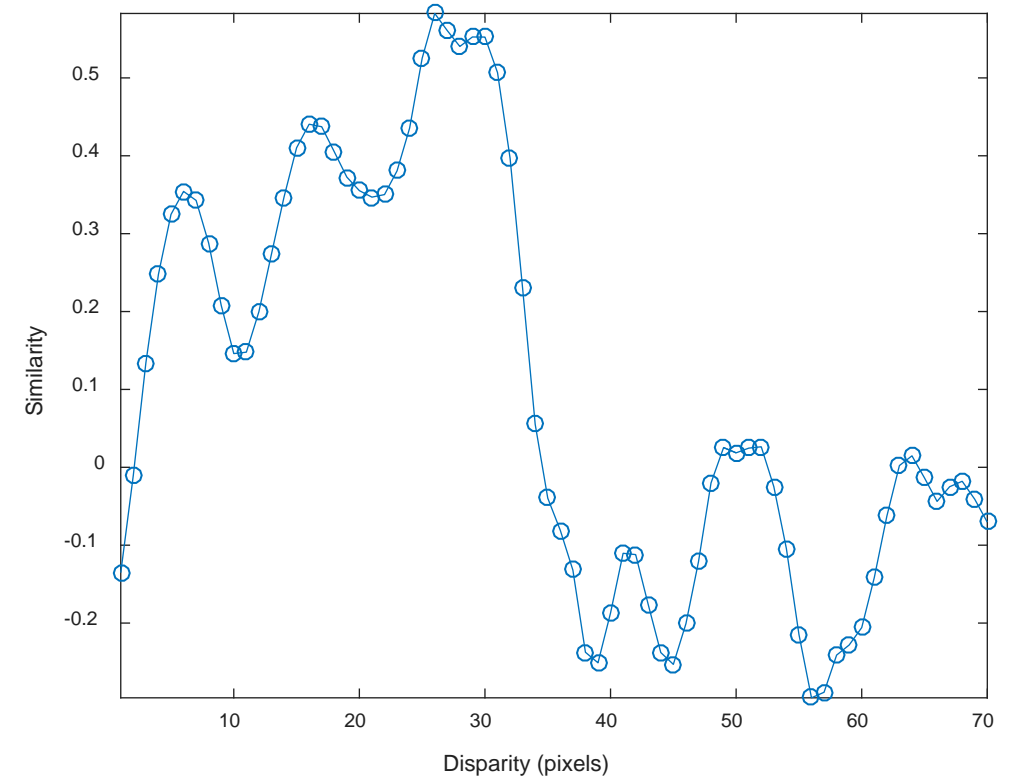

Stereo matching failures



- A weak peak
 - Often occlusion, parallax

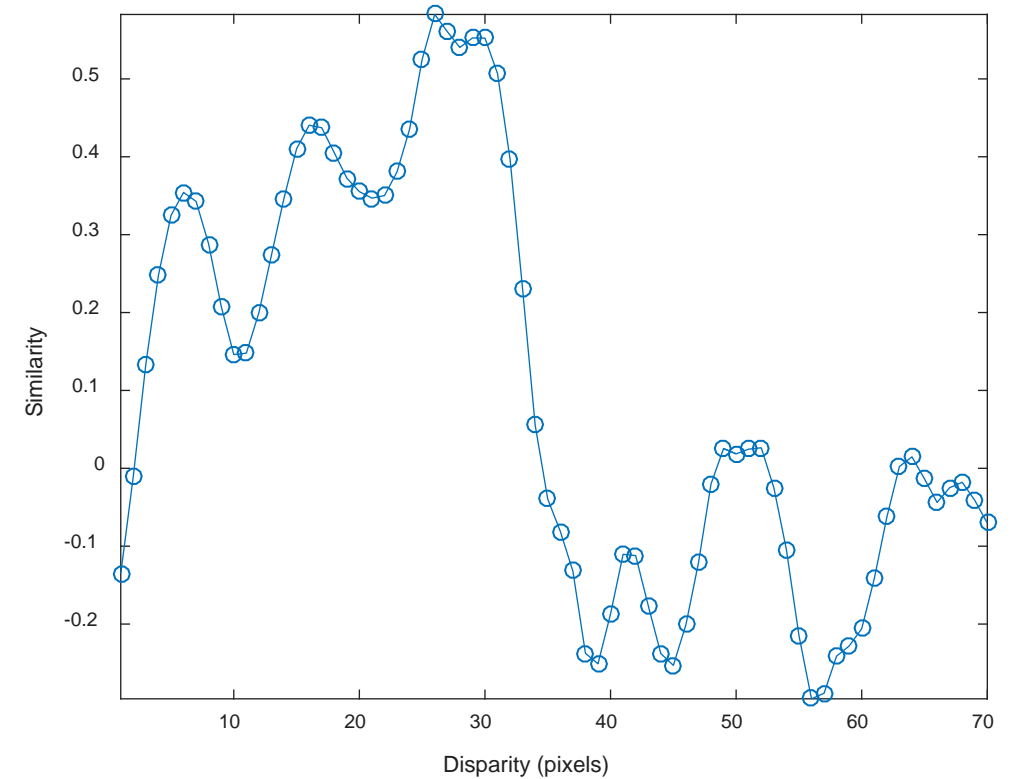

Stereo matching failures



- A weak peak
 - Often occlusion, parallax

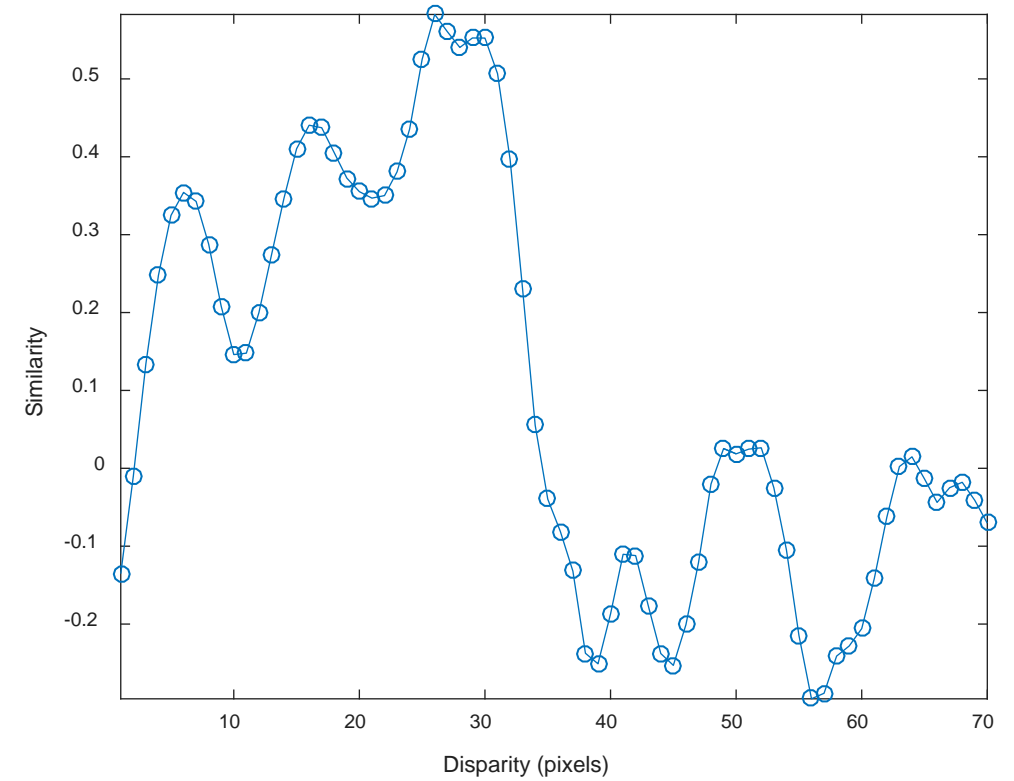

Stereo matching failures

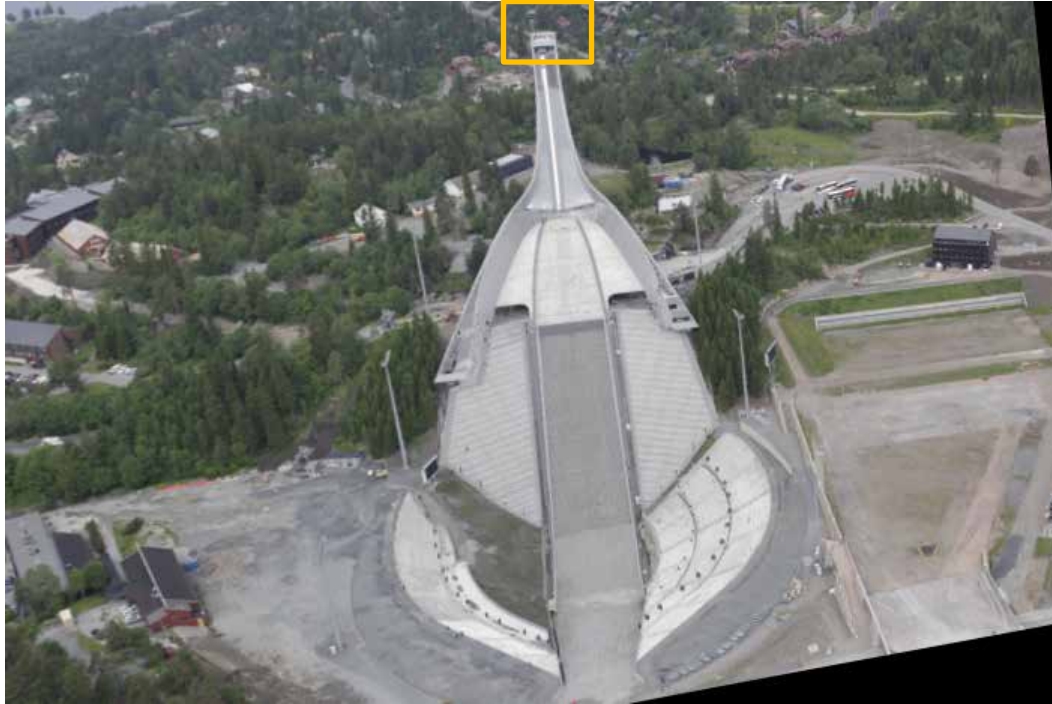

- A weak peak
 - Often occlusion, parallax
 - Worse with larger baseline
 - Detect by thresholding similarity score

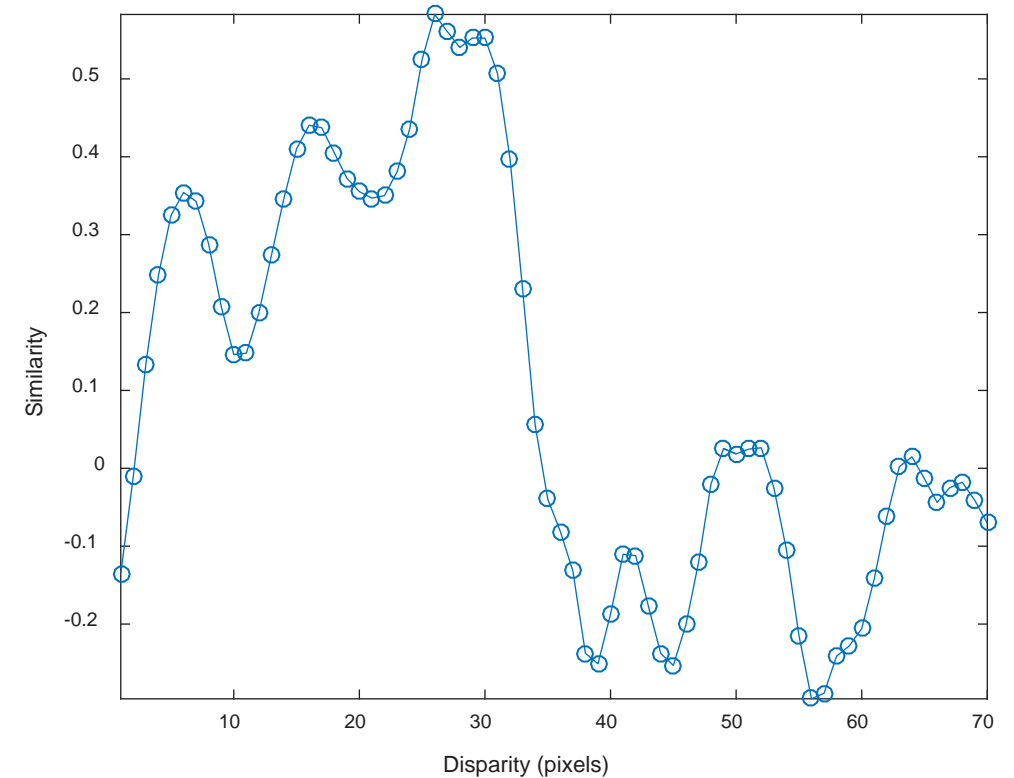

Stereo matching failures



- A weak peak
 - Often occlusion, parallax
 - Worse with larger baseline
 - Detect by thresholding similarity score

Stereo matching failures



- A broad peak
 - Little texture
 - Detect with texture metrics or from peak estimates

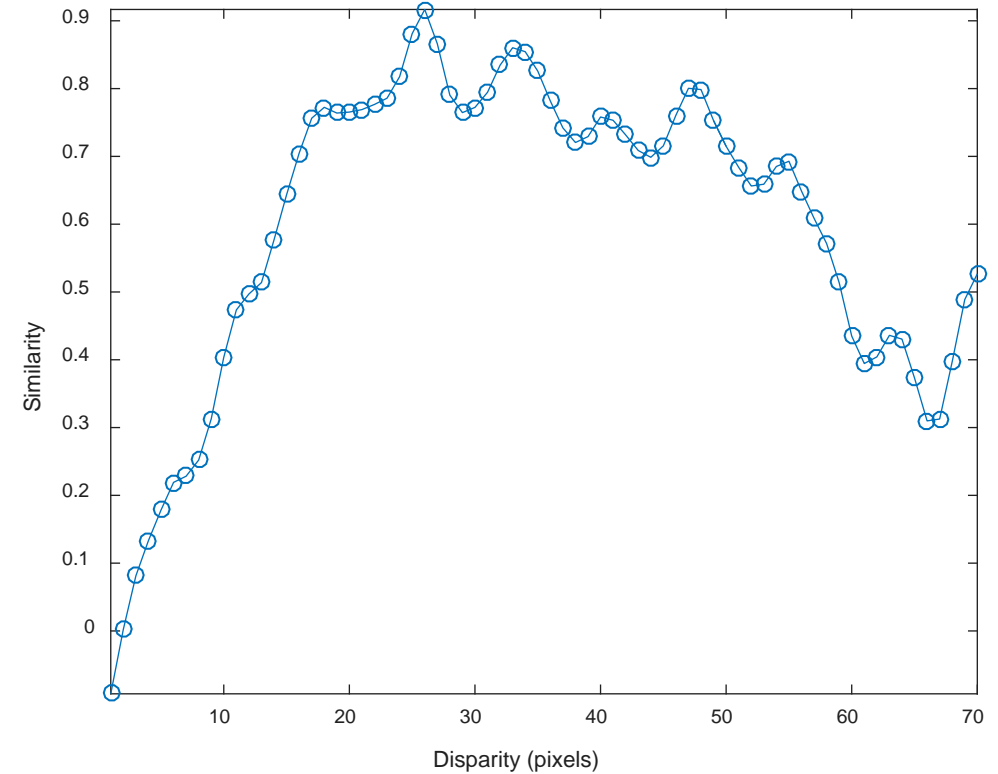

Determining position of peaks

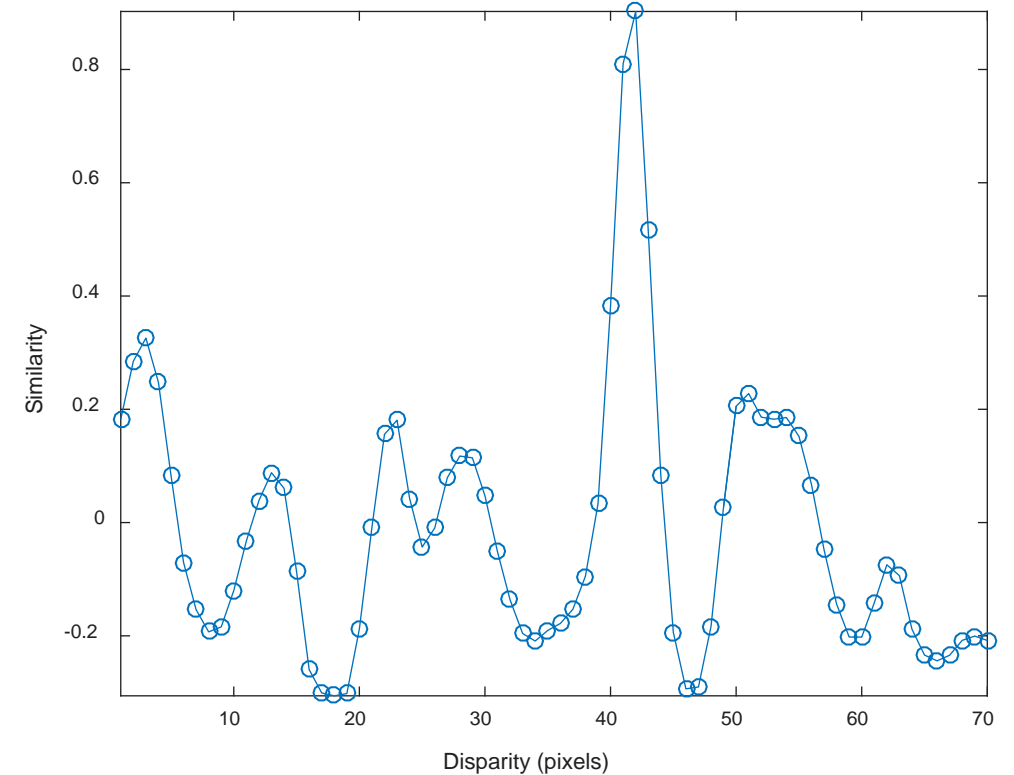
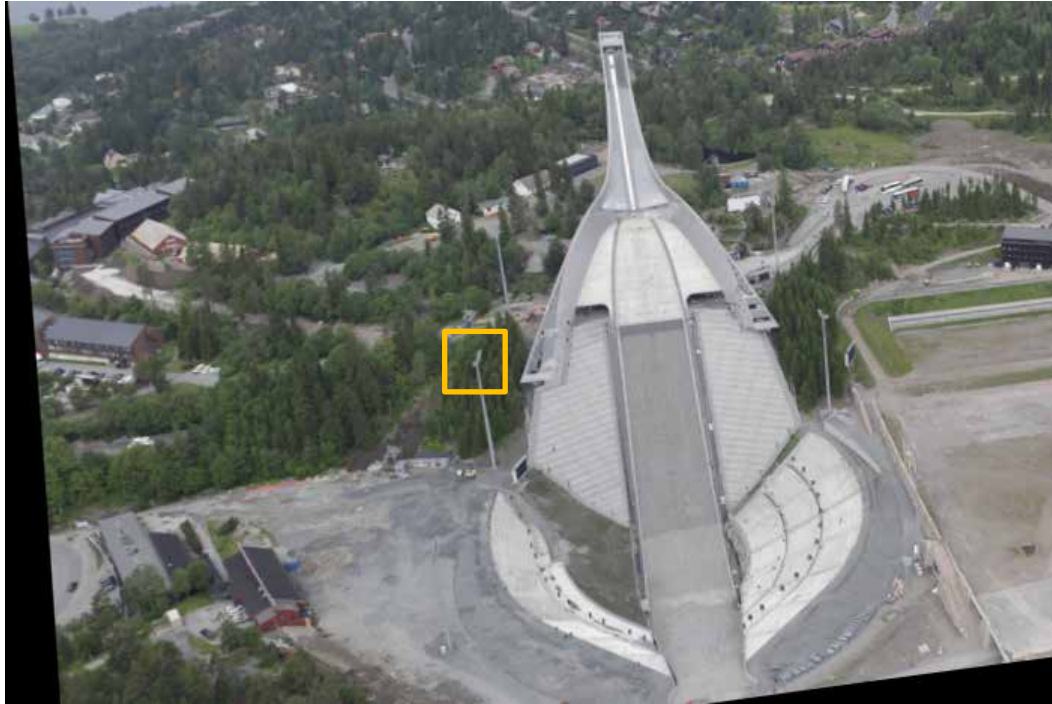

- Fit a parabola to the peak and its neighbors
 - $s = Ad^2 + Bd + C$
 - $\hat{d} = \frac{-B}{2A}$
- Avoids steps in depth

Dense stereo example



Dense stereo example

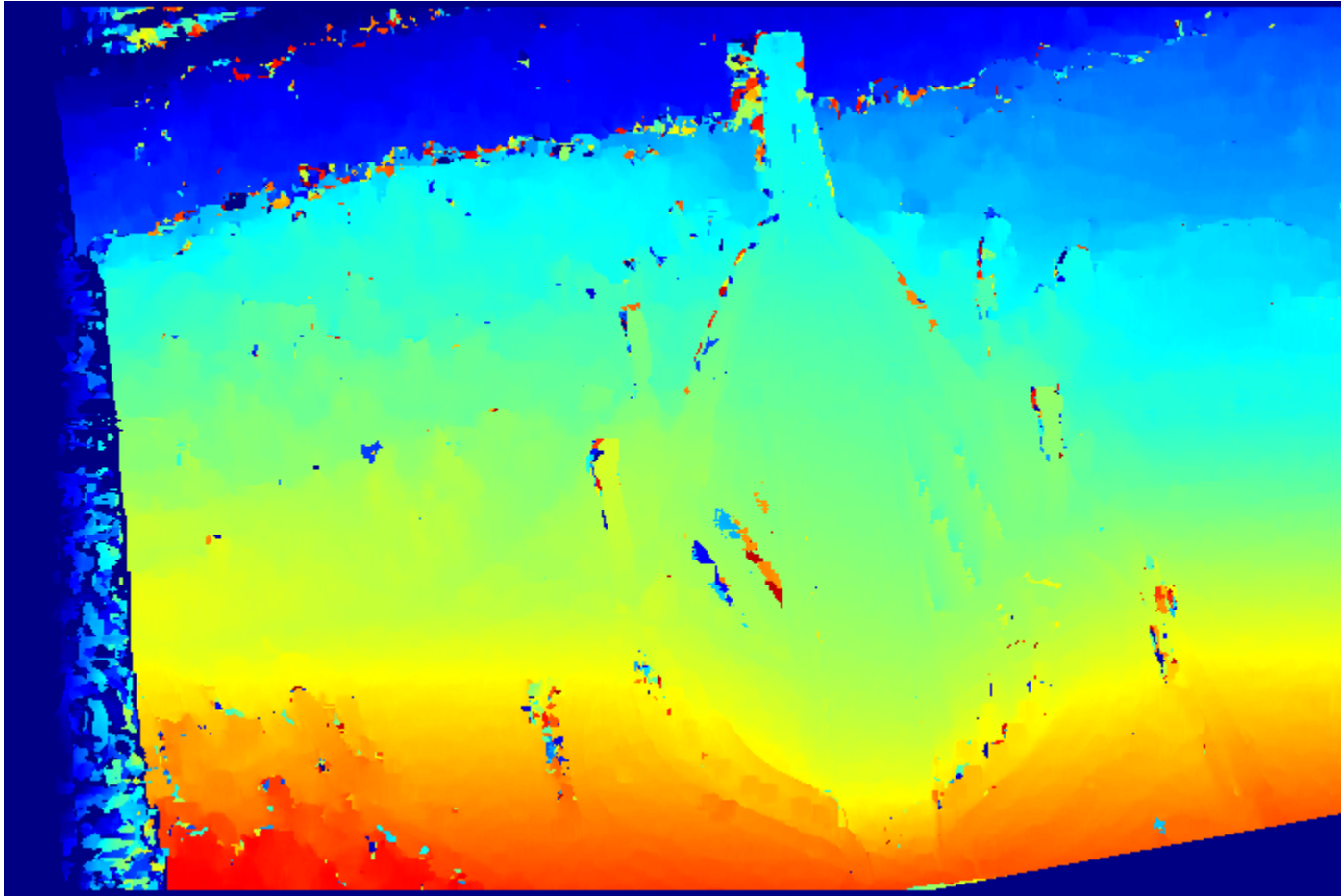

- Raw disparity image

Dense stereo example

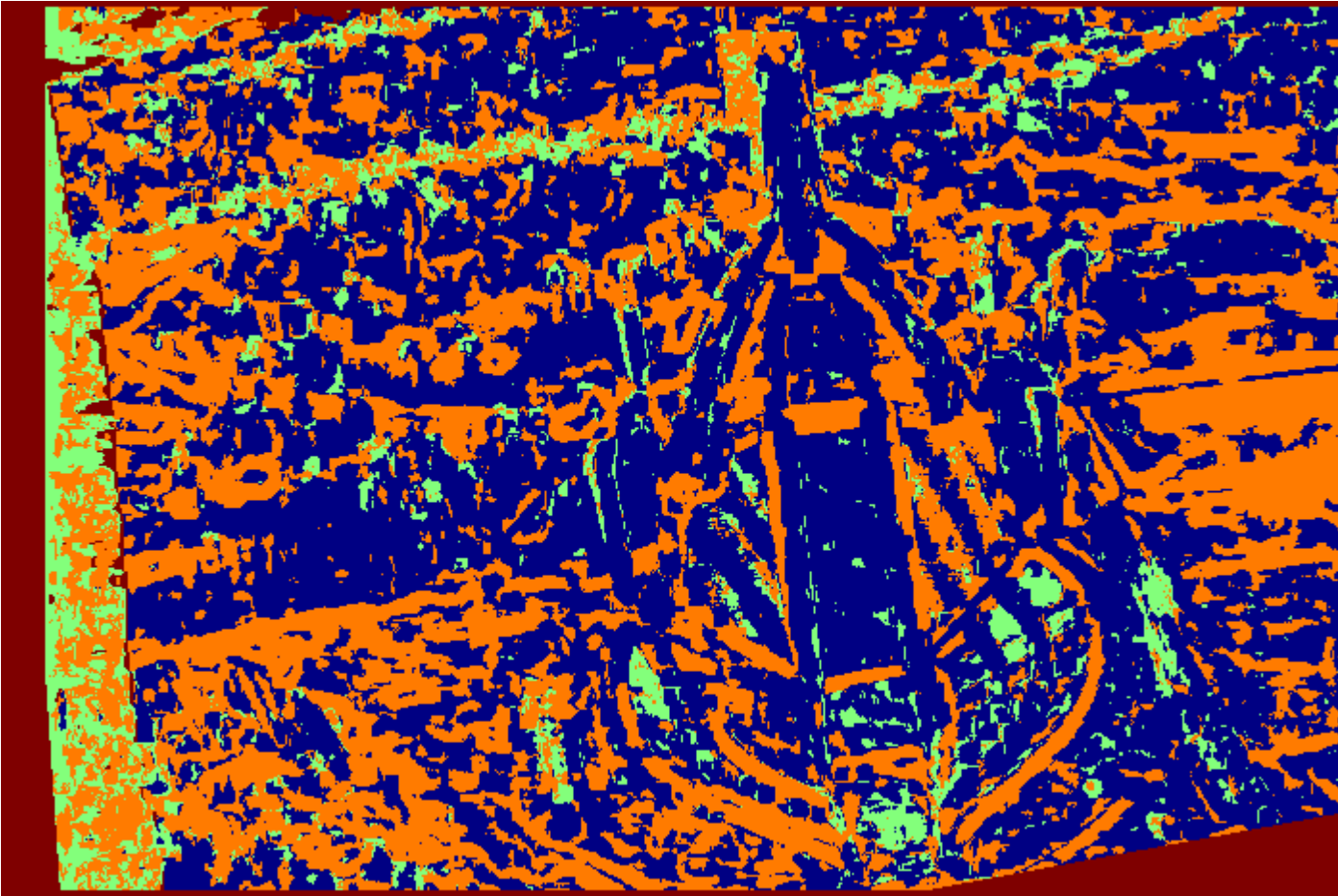

- Detection of failures
 - Blue: Ok
 - Red: Outside image
 - Orange: Broad peaks
 - Green: Low similarity
- In computer vision in general:
 - Smooth and fill holes
- In robotics:
 - Typically better to remove uncertain points

Dense stereo example

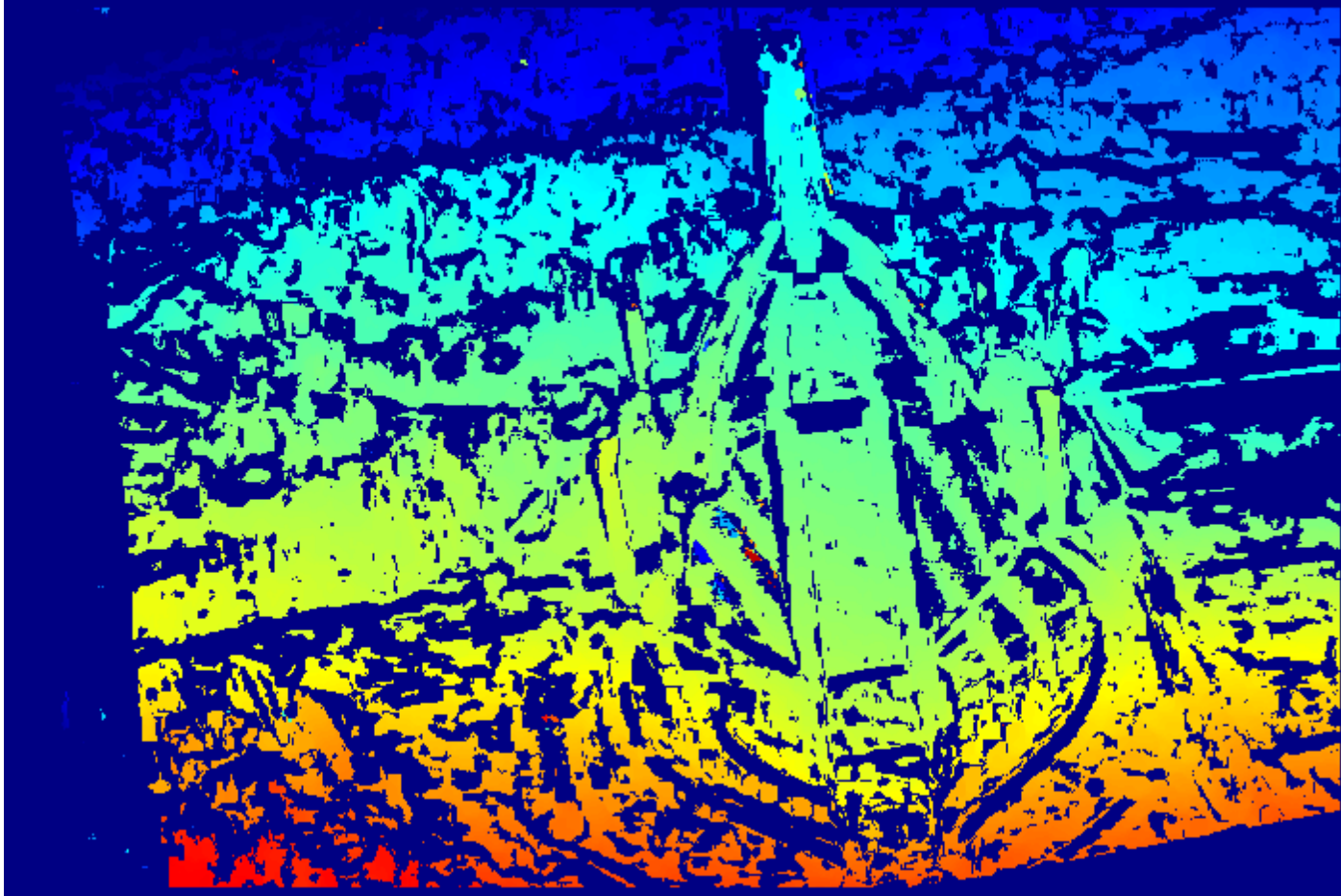

- Disparity image
 - Failures removed

Dense stereo example

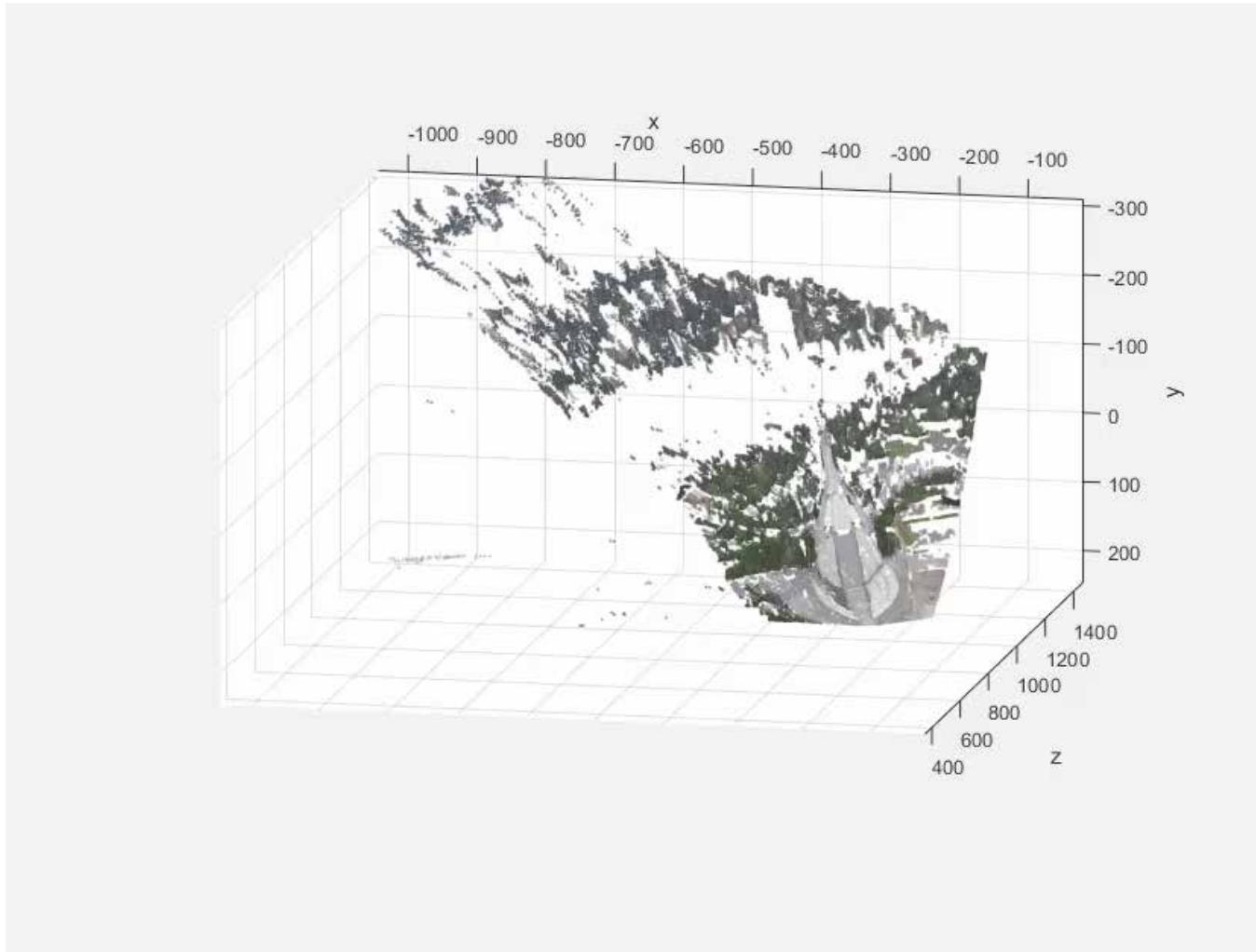

- Dense 3D point cloud

Smooth stereo: Global optimization



- Instead of finding best disparity for each pixel, find d so that global energy is minimum:

$$E(d) = E_d(d) + \lambda E_s(d)$$

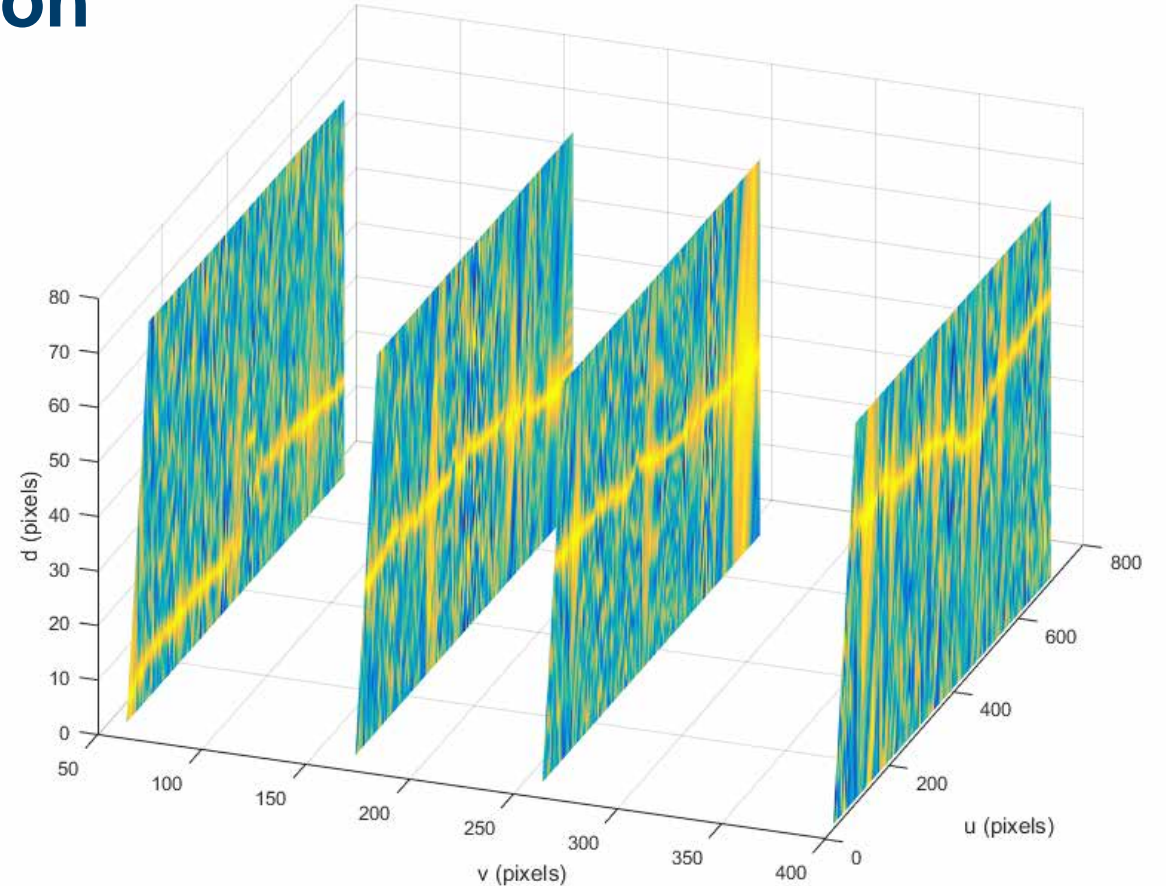

Semi Global Matching example



- SGBM
Heiko Hirschmuller, “Stereo processing by semiglobal matching and mutual information”.
Pattern Analysis and Machine Intelligence, IEEE Transactions on, 30(2):328–341, 2008

Semi Global Matching example

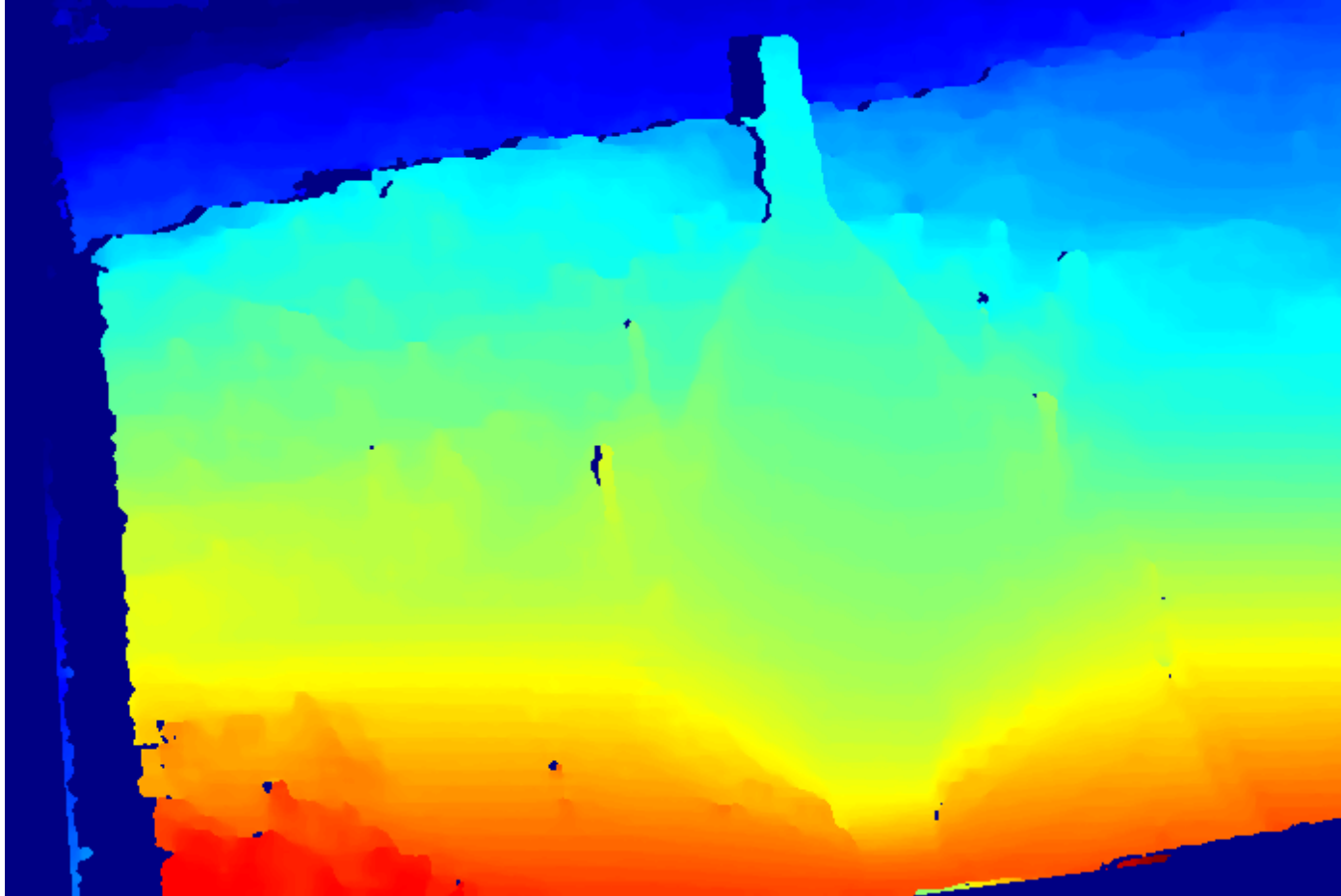

- SGBM
Heiko Hirschmuller, “Stereo processing by semiglobal matching and mutual information”.
Pattern Analysis and Machine Intelligence, IEEE Transactions on, 30(2):328–341, 2008
- Disparity image

Semi Global Matching example

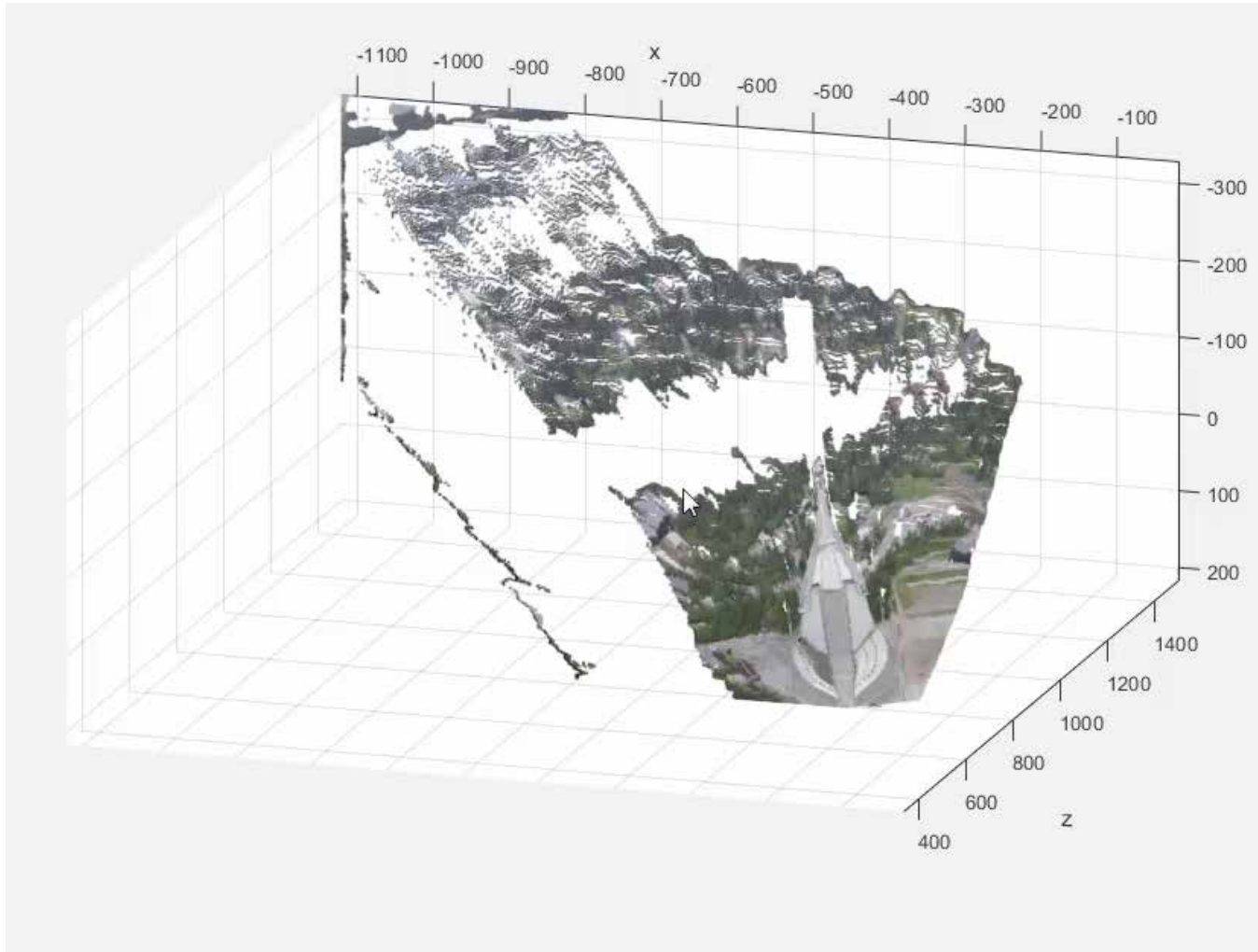

- **SGBM**
Heiko Hirschmuller, “Stereo processing by semiglobal matching and mutual information”.
Pattern Analysis and Machine Intelligence, IEEE Transactions on, 30(2):328–341, 2008
- 3D point cloud

Semi Global Matching example

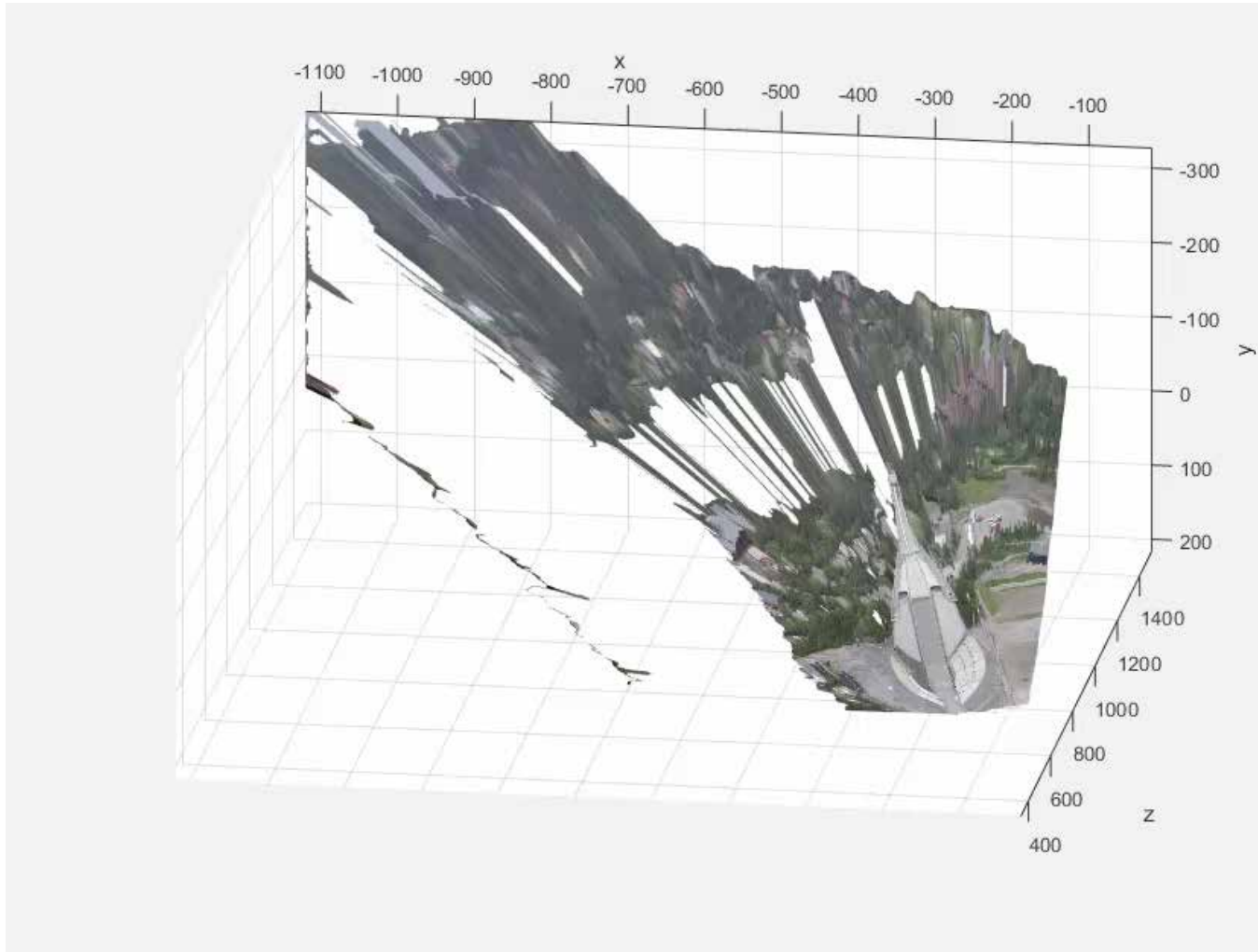

- **SGBM**
Heiko Hirschmuller, “Stereo processing by semiglobal matching and mutual information”.
Pattern Analysis and Machine Intelligence, IEEE Transactions on, 30(2):328–341, 2008
- Textured surface

Summary

- Stereo imaging
 - Horizontal epipolar lines
 - Disparity
 - 3D from disparity
 - Stereo rectification
- Stereo processing
 - Sparse vs dense matching
 - DSI
 - Typical failures
 - Removing failures vs smoothness
- Additional reading
 - Szeliski: 11.2-11.5
 - <http://vision.middlebury.edu/stereo/>
- Matlab toolkit:
 - Peter Corke's Robotics Toolbox and Machine Vision Toolbox
 - <http://www.petercorke.com/Toolboxes.html>
- Lab:
 - Make your own stereo camera!