

High temperature

High temperature is a relative term

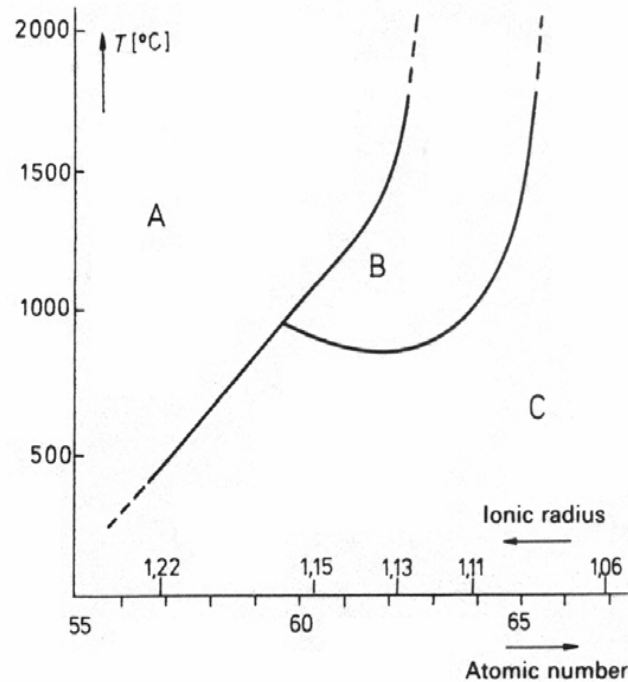

Fig. 1. Phase diagram for trivalent lanthanoid oxides, after Goldschmidt. For the A-, B-, and C-types, see text.

We use high temperature in order to reach stability areas of new phases and to increase reaction rates by increasing the mobility of atoms, ions and species...

Problems related to instrumentation and equipment increases exponentially with temperature

Methods

Mechanical processes

- Adiabatic compression ($> 10^3$ °C)
- Adiabatic shock waves ($> 10^4$ °C)

Resistance heating

- Cr/Ni (1100 °C)
- SiC (1500 °C)
- Pt/Rh (1700 °C)
- MOSi₂ (1800 °C)
- MO(H₂) (2000 °C)
- C (2500 °C)
- ZrO₂ (2500 °C)
- MO₂ + M₂O₃ (2000 °C)

Electron-beam heating

- Focal spot fusion
- Drip fusion (> 3000 °C)

Thermochemical processes

Flames

- 2H₂ + O₂ (2660 °C)
- C₂H₂ + O₂ (3100 °C)
- C₂H₂ + N₂O (> 3100 °C)
- Metal powder/O₂ flames
- "skating sun"
- (≈ 2500 — 4500 °C)

Metallothermy

- Metal oxides, sulphides, and halides + Al, Mg, Ca, Zr, etc.
- (≈ 2000 — 2500 °C)

Electrical processes

Induction heating

- Inductive heating of electrically conducting substances
- Crucible-free fusion
- Open plasma torch ($> 10^4$ °C)
- Closed plasma torch (thermal disequilibrium)
- ($\approx 10^3$ — 10^4 °C)

Electric arc

- Arc fusion (> 3000 °C)
- Electric-arc plasma torch ($> 10^4$ °C)
- Arc-transport process (≈ 2000 — 4000 °C)
- Artificial suns (≈ 2300 °C)

Natural heat sources

- Solar furnaces
- (≈ 3500 °C)

Laser

- High-power CO₂ laser (> 4000 °C)

Measuring temperature

Oscillator	150 °C
Liquid filled thermometer	400 °C
Thin film thermometer	500 °C
IR thermometer	? °C
Thermocouple	1500 °C
Optical pyrometri	2500 °C



Electron beam

Ca. 100 kVA

Vacuum ca. 10^{-3} mbar

Protected cathode

Small scale in electron
microscopes

Needs a conducting sample

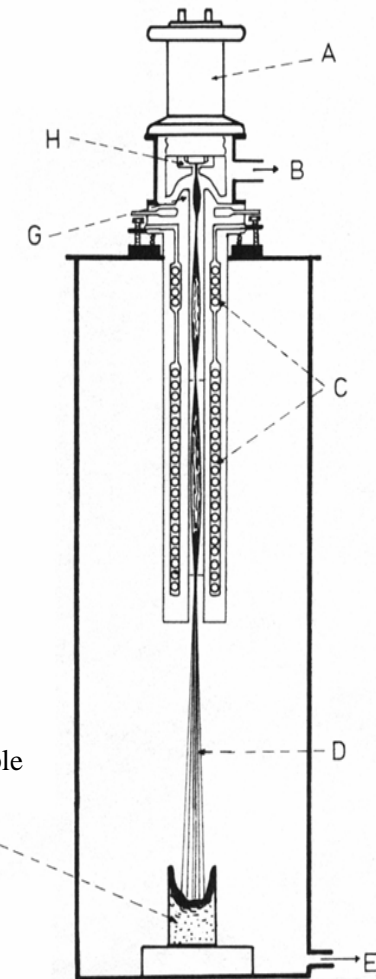

Fig. 2. Principle of an electron gun [25] for metal fusion in a field-free space. A: Insulator; B: pump for the electron gun; C: magnetic lenses; D: electron beam; E: pump for the preparation space; F: preparation; G: anode; H: cathode.

Electric arc

Up to 7000 °C

A small distance between cathode and anode makes it possible to use low voltage

The heat is generated by a large current

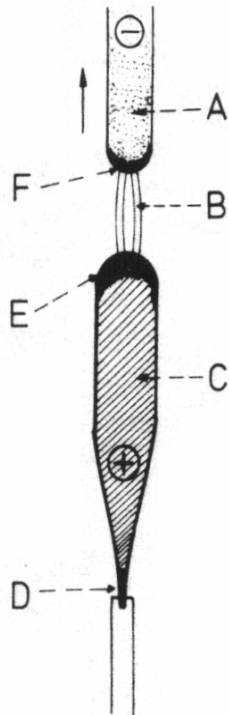

Fig. 3. Schematic representation of the arc transport process [30] for growing single crystals with transportation of the material in an arc. A: Feed electrode; B: arc; C: growing crystal; D: seed crystal; E: anode melt; F: cathode melt.

Resistance heating

Current is passed through a conducting material.

Heat is generated by the electric resistance

The atmosphere is important

e.g. super kanthal to 1800°C

Molybdenum

Graphite

May also use conducting oxides as heating elements (including transparent conducting oxides)

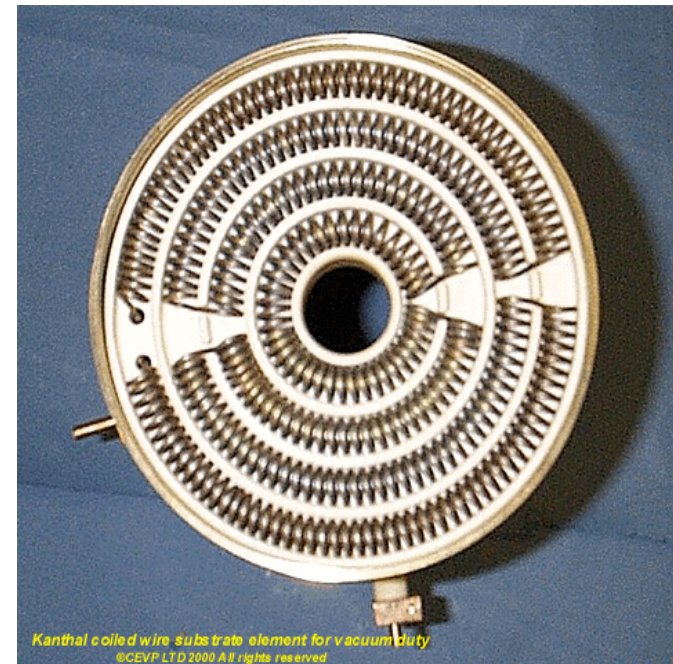

Induction heating

By sending high frequency current (AC) through a copper coil, eddy currents are created in the enclosed (conducting) material, which will heat up the material.

The copper coil is often a watercooled tube

May allow crucible-less heating of metals.



7

Sun-furnaces

Based on focused light.

Surprisingly stable temperature (2700°C, 1 hour, ± 10 °C)

The sample may be in vacuum or inert gas

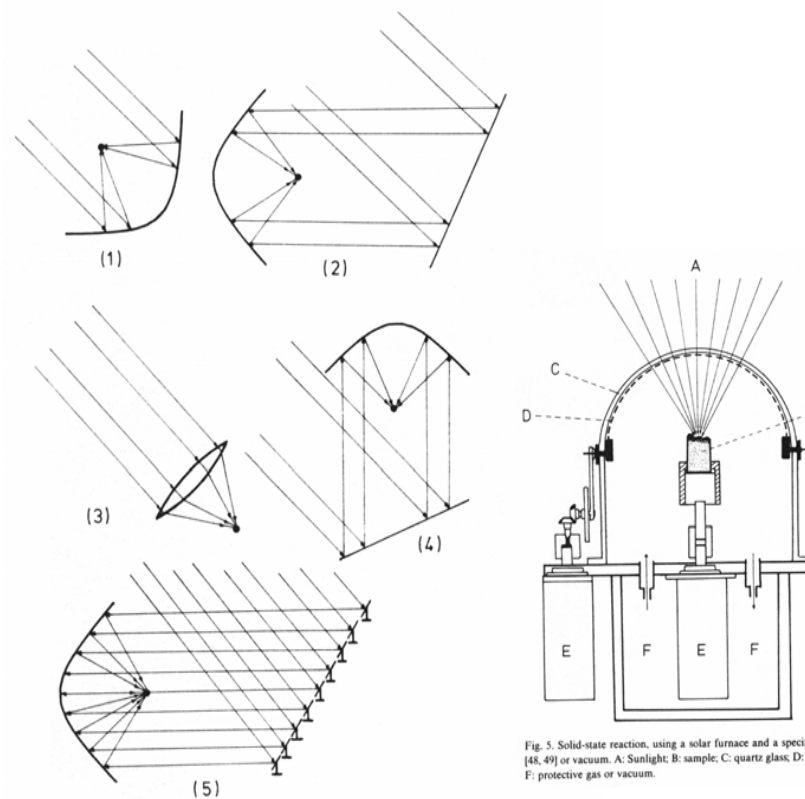

Fig. 5. Solid-state reaction, using a solar furnace and a specific gas atmosphere [48, 49] or vacuum. A: Sunlight; B: sample; C: quartz glass; D: stripper; E: motor; F: protective gas or vacuum.

Fig. 4. Types of solar furnaces: (1) direct solar furnace; (2) horizontal heliostat; (3) type with a single lens; (4) vertical heliostat; (5) large-scale horizontal heliostat with illumination of the parabolic mirror by several plane mirrors.

8

Artificial sun

An arc or lamp may be used as a light source for focused light furnaces. The temperature is not as high as by using sun light

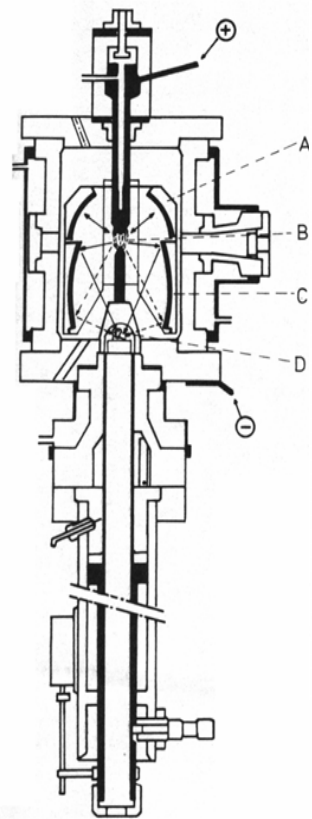

Fig. 7. Section through an electric arc furnace [52] for preparations under a specific gas atmosphere. A: Spherical mirror; B: electric arc; C: elliptical mirror; D: sample under a protective cap.

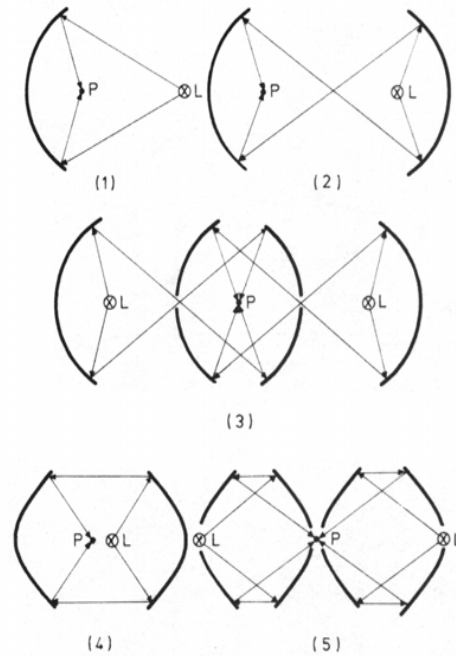

Fig. 6. Fundamental construction of optical heat sources (artificial suns). (1) Simple elliptical furnace; (2) double elliptical furnace; (3) multimirror system for two light sources with elliptical mirrors; (4) double mirror furnace with parabolic mirrors; (5) multimirror system for two light sources with parabolic mirrors (P = preparation; L = light source).

Plasma torch

Temperatures of 8000 – 50 000°C

The plasma is produced by a strong electrical field across the gas, either arc or high frequency.

A fast gas stream prevents the current reaching the electrodes.

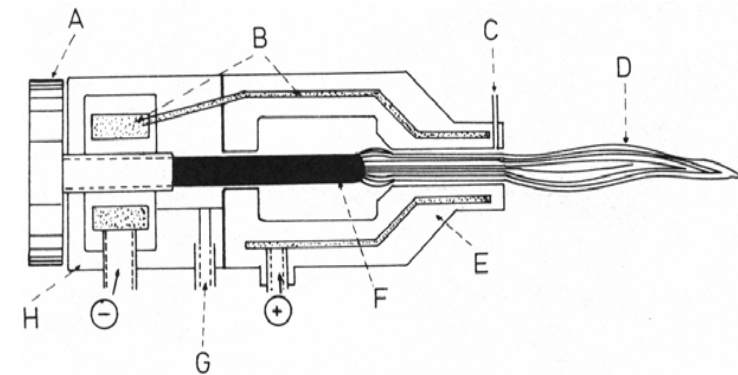

Fig. 10. Principle of an electric-arc plasma torch [78] for processing powdered materials. A: Adjustable electrode support; B: cooling; C: powder feed; D: plasma; E: anode; F: cathode; G: fuel gas supply; H: insulator.

Plasma III

It is possible to create plasma in vacuum systems (0.1 – 1 mbar)

Use RF for producing the plasma

Often used to activate complexes.

Plasma II

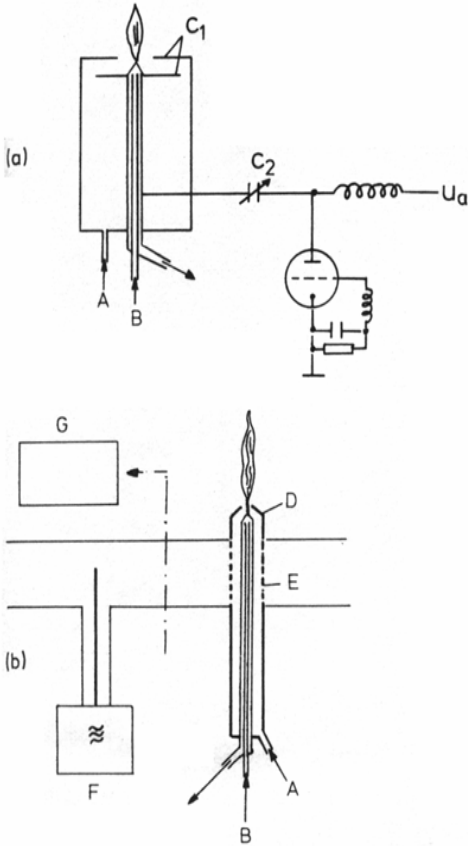

Fig. 12. Mode of operation of high frequency open plasma torches [92] (a) for several hundred MHz, (b) for 2400 MHz. A: Fuel gas; B: cooling; C₁, C₂: capacitors; D: nozzle; E: electrode; F: HF generator; G: cross section.

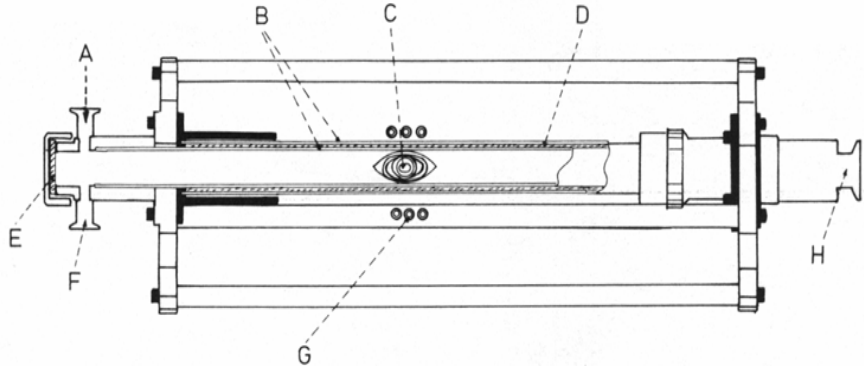

Fig. 13. Principle of a closed (low-pressure) plasma torch [100, 101] with inductive coupling of the HF energy. The torch can be displaced in a horizontal direction. The induction coil is fixed. A: Gas inlet (plasma gas); B: quartz tube; C: plasma; D: water cooling; E: window; F: pressure control; G: introduction coil; H: vacuum.

Laser

The material should absorb radiation corresponding to the wavelength of the laser in order to create heat. (CO₂ laser: 10.6 μm)

Often used in thin film methods (ablation).

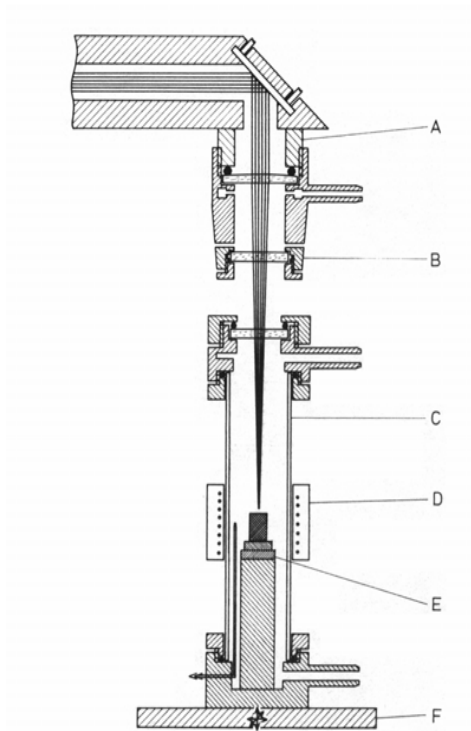

Fig. 14. Schematic representation of the performance of a high-temperature reaction with CO₂ laser energy under a specific atmosphere [121]. A: Collimator and focusing unit; B: protective window; C: sample space with the protective gas atmosphere; D: resistance heating; E: sample carrier; F: rotary, cross-slide and lifting stage.

Crucibles

Inert metal, Ni, Pt, Ir

Alumina

Zirconia

Copper cooled crucible

Centrifuged crucible

Crucible-less melting (air stream, levitation)

Possible interdiffusion with crucible material

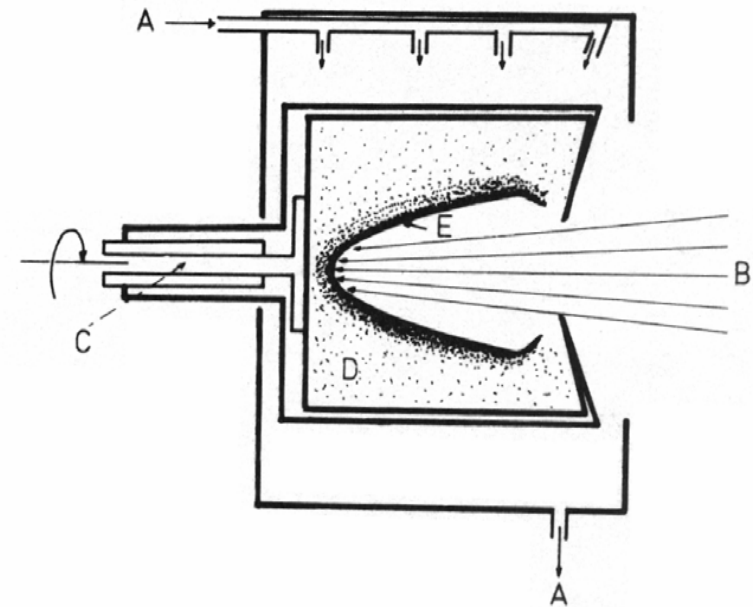

Fig. 9. Principle of the high-temperature centrifuge technique [73] for the prevention of wall reactions ("self-crucible method") in the heating of solids with radiant energy. A: Cooling; B: sunlight; C: centrifuge axis; D: solid phase; E: liquid phase.

Microwave

May be used for e.g. inorganic chalcogenides etc.

Metal must be crushed to small particles

Very fast heating (10 – 500 °C/min)

Used also for hydrothermal reactions and decomposition

