

UNIVERSITY OF OSLO
Faculty of Mathematics and Natural Sciences

Exam: MEF 3000 / MEF 4000 – Functional materials
Day/time: Friday 9. December, kl. 14.30 – 17.30
Duration: 3 hours
The set is on: 9 pages including 4 appended papers (5 tasks)
Allowed aids: Calculator, colors, ruler and similar
Language: English

Candidate number:

Note:

Write your candidate number on page 1, and control that the set is complete before you begin to answer the tasks.

All tasks require only short answers. Remember therefore to answer shortly in order to be able to complete the set.

Task 1: Structure (30%).

Given the following structural data:

Imm2

$a = 3.5024 \text{ \AA}$, $b = 5.3789 \text{ \AA}$, $c = 5.5209 \text{ \AA}$

Na	2a	$z = 0.58833$
N	2a	$z = 0.12277$
O	4c	$x = 0, y = 0.19646$

In the table for this space group the following information is given about the positions.

Positions

Multiplicity,	Wyckoff letter,	Site symmetry	Coordinates			
			(0,0,0)+	($\frac{1}{2}, \frac{1}{2}, \frac{1}{2}$)+		
8	e	1	x, y, z	-x, -y, z	x, -y, z	-x, y, z
4	d	m..	0, y, z	0, -y, z		
4	c	.m.	x, y, 0	-x, -y, 0		
2	b	mm2	0, $\frac{1}{2}$, z			
2	a	mm2	0, 0, z			

a) What type of crystal system is this? **Orthogonal**

What is the Bravais lattice of this crystal system? **Body centered**

Give the corresponding point group for the given space group. **mm2**

b) What is the chemical formula for this material? **NaNO₂**

How many formula units does the unit cell contain? **2**

c) Make a stereographic projection of this point group and note how many times a general position is repeated.

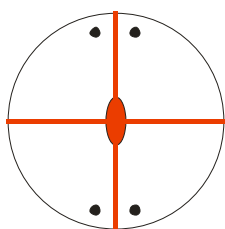

d) Draw the structure as a projection on the **bc** plane. Draw in the N–O bonds. (Feel free to use one of the appended grids for your answer).

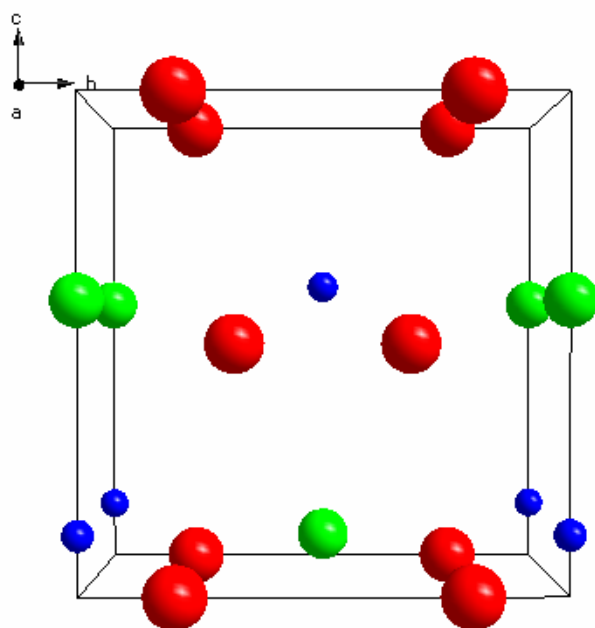

The coordinates are:

Na: (0, 0, 0.58833), (0.5, 0.5, 0.08833)

N: (0, 0, 0.12277), (0.5, 0.5, 0.62277)

O: (0, 0.19646, 0), (0, 0.80354, 0), (0.5, 0.69646, 0), (0.5, 0.30354, 0.5)

e) What is the distance between a N and one of the nearby O?

1.2554 Å

f) Can you from the stereographic projection and your structure drawing comment on whether this compound may be piezoelectric or not?

It is not centrosymmetric and contains polar NO₂ units and may thus be piezoelectric.

g) At higher temperature, a phase transition occurs that gives this compound the space group Immm. The structure can be visualized by adding the atoms:

Na 2a z = 1-0.58833 = 0.41167

N 2a z = 1-0.12277 = 0.87723

to the drawing that you did in b), do this.

In practice this is a mirroring of all the points along the c-axis.

Each atom that is mirrored will have an occupation number of 0.5. In this way there is a 50% chance to find an atom on that position or not. Also one avoids so close atomic positions that the operation otherwise would have given. Told in another way, the atoms are jumping back and forth between the two nearest positions in the structure.

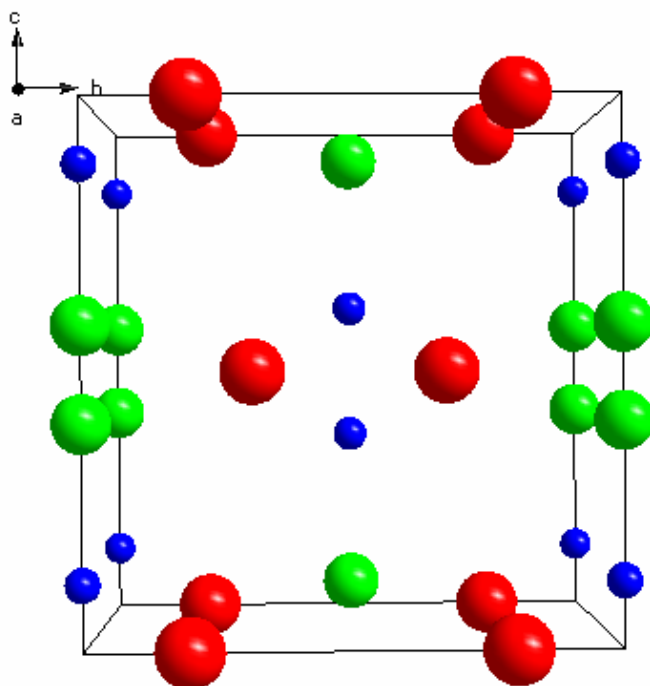

The extra coordinates are:

Na: (0, 0, 0.41167), (0.5, 0.5, 0.091167)

N: (0, 0, 0.87723), (0.5, 0.5, 0.37723)

- h) Make a stereographic projection for the corresponding point group for the space group $Immm$. Note a general position and how this is being multiplied.

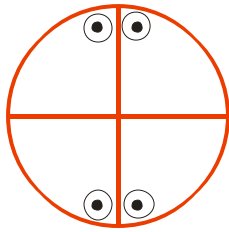

8 times.

- i) Can you on the basis of the new stereographic projection, and the new structure drawing comment on whether this compound may be piezoelectric at high temperatures or not?

The new space group is centrocymmetric and can thus not be piezoelectric.

Task 2: Phase diagrams (14%).

a) Draw schematic one or more phase diagrams that together contains at least one of each of the following reactions:

- Eutectic reaction
- Peritectic reaction
- Congruent melting
- Eutectoid reaction
- Peritectoid reaction

b) There are some errors in the phase diagram below (or rather special situations). Mark these on the figure and discuss these in the context of the phase rule. (Feel free to use one of the appended copies for your answer.)

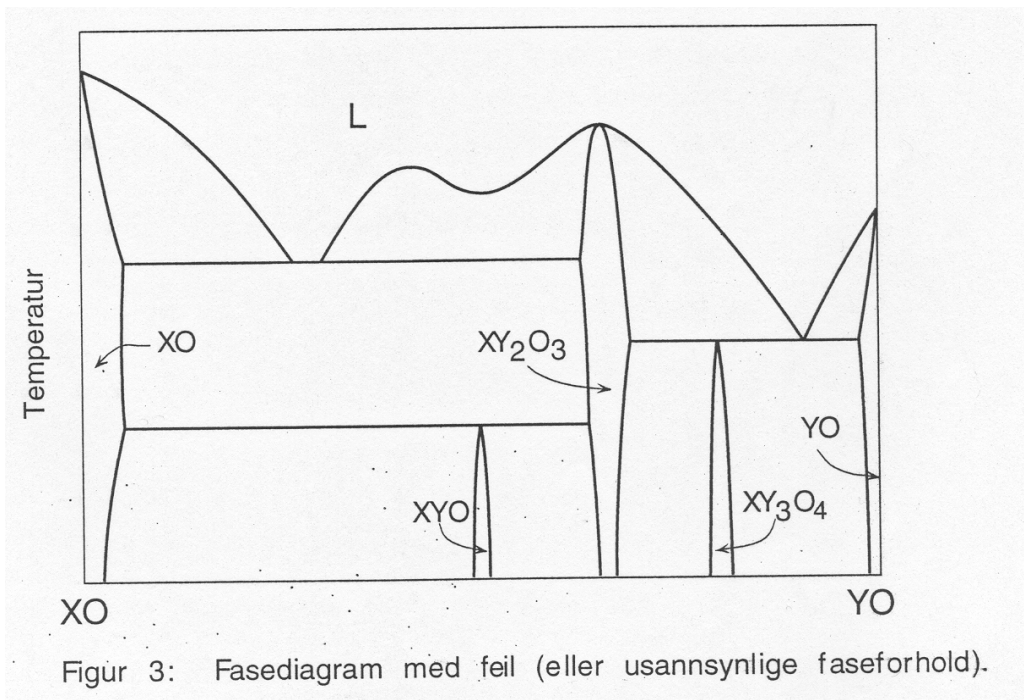

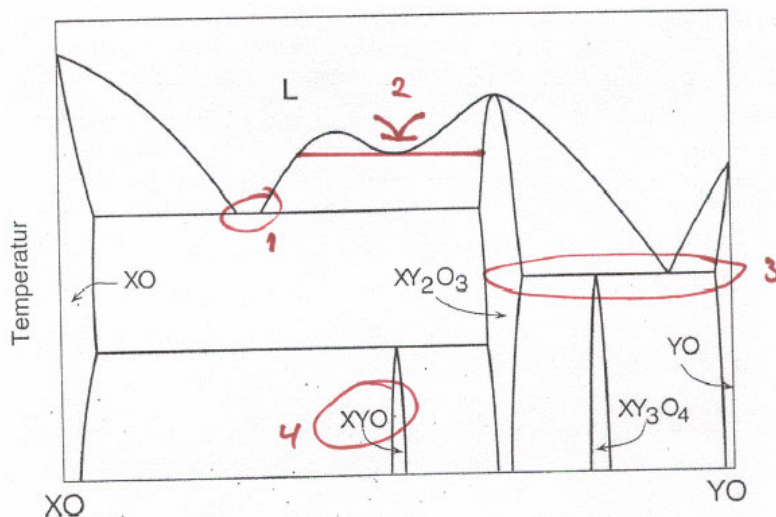

Figur 3: Fasediagram med fejl (eller usannsynlige faseforhold).

1: The liquid can not have a composition range since this is an invariant reaction according to the condensed Gibbs phase rule ($P + F = C + 1$). The number of components are 2 (XO, and YO), and the number of phases in equilibrium are 2 (XO, L, XY_2O_3).

2: There should be a horizontal line here that indicates that there is a monotectic reaction, viz. an invariant reaction. The phases that are in equilibrium are XY_2O_3 , L1 and L2.

3: This situation indicates that there are four phases in equilibrium: XY_2O_3 , XY_3O_4 , L and YO. This apparently violates the condensed Gibbs phase rule. However, if one considers the complete Gibbs phase rule ($P + F = C + 2$) and inserts $P = 4$, $C = 2$ one obtains $F = 0$ and it is possible. This situation can be considered as a very special situation and can occur if the stability of the XY_3O_4 phase or the eutecticum temperature is pressure dependent. This binary phase diagram can then be taken at the magic pressure where these four phases are in equilibrium.

4: The composition XYO can not be described from the end members XO and YO and can thus not be part of this diagram.

- c) Consider a hypothetical binary oxide system $AO_2 - B_2O_3$ with one incongruently melting phase AB_2O_5 . Assume that there is no solid solubility. Draw the phase diagram.

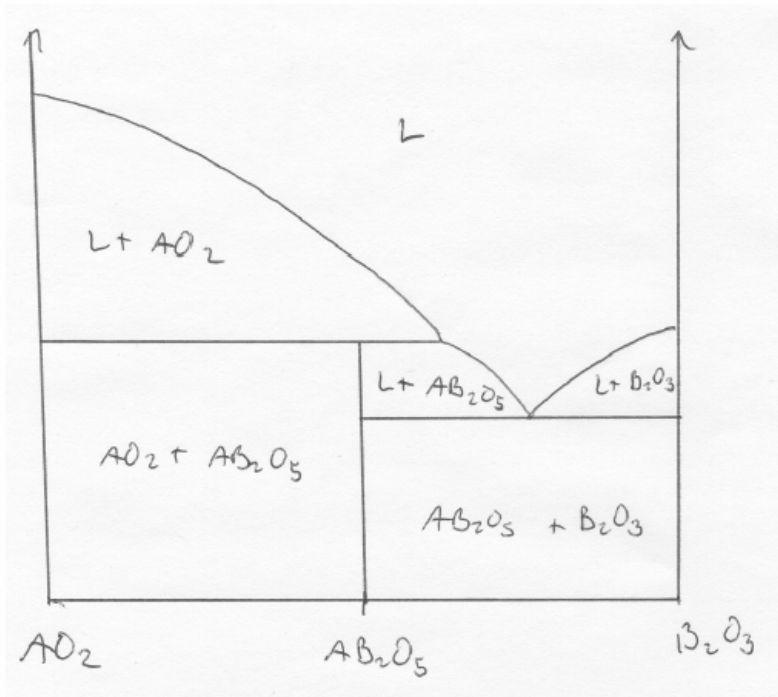

Task 3: Magnetism (13%).

a) What is magnetic susceptibility? Describe shortly.

The willingness of a material to become magnetized.

b) Write the Curie and the Curie-Weiss relationship for ferromagnetic, paramagnetic and anti-ferromagnetic materials. Draw the $1/\chi$ versus temperature (χ is magnetic susceptibility) and explain how the constant θ varies between the different types of magnetism.

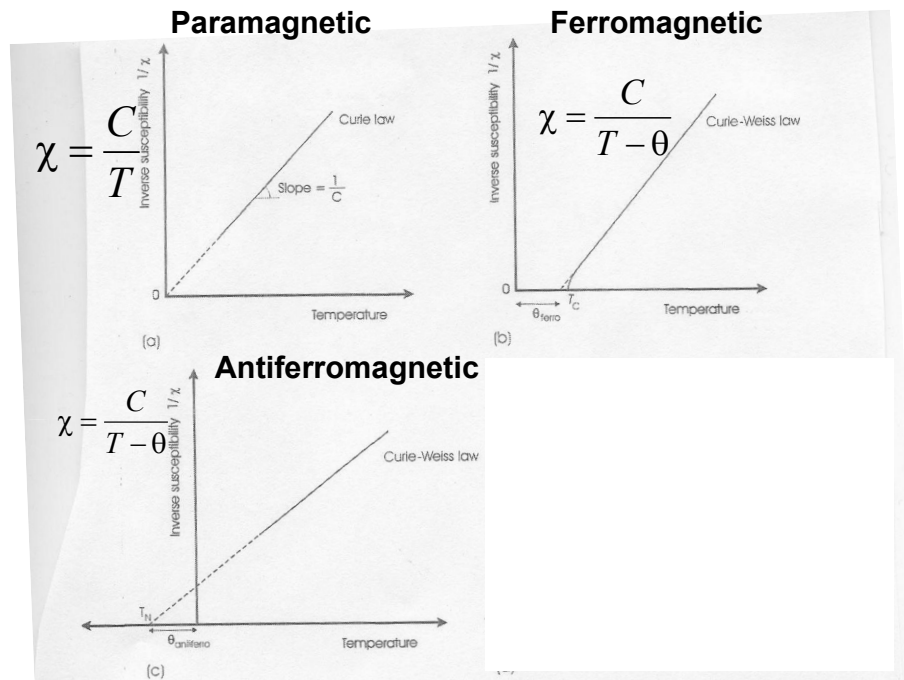
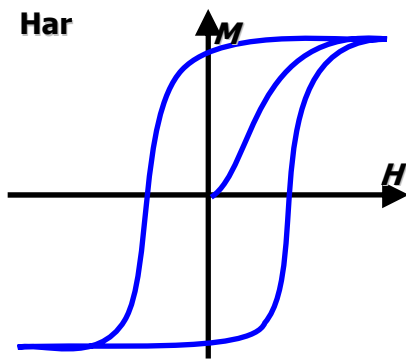
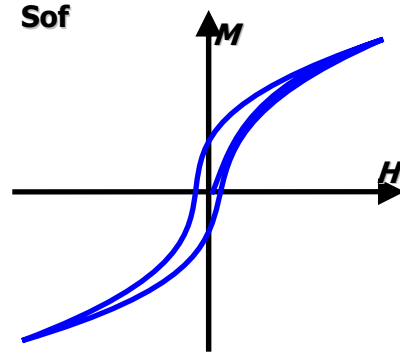

Figure 12.4 The temperature dependence of the reciprocal magnetic susceptibility: (a) Curie law behaviour of a paramagnetic solid; (b) Curie-Weiss law behaviour of a ferromagnetic solid above the Curie temperature, in the paramagnetic state; (c) Curie-Weiss law behaviour of an antiferromagnetic solid; and (d) behaviour of a ferrimagnetic solid

c) What are the characteristics of a hard and a soft magnet? Describe shortly.



Hard to to magnetize and demagnetize
 Very large remanence
 Can be made into permanent magnets
 High coercivity



Easy to magnetize and demagnetize
 Minimal remanence
 Low coercivity

- d) Consider the structural elements below for two octahedrons of MnO_6 that are connected together in their corners. If the electron spin points up for the first manganese, what is the likely orientation of the electron spin at the other manganese?

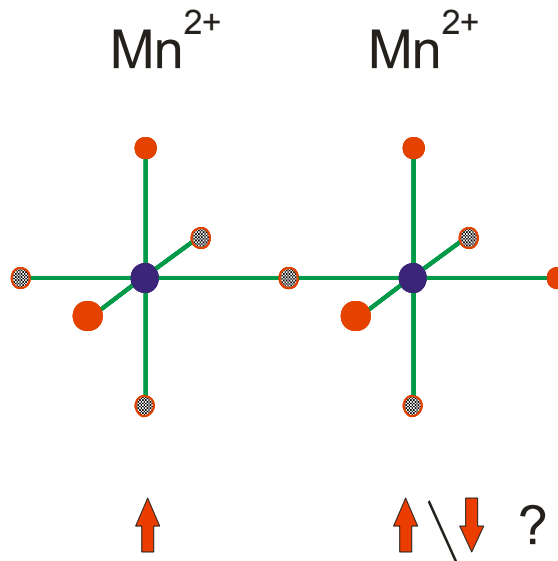

How will a tilting / rotation of these octahedrons in relation to each other affect the magnetic exchange and transition temperature?

The exchange mechanism here is super exchange with an oxygen in between and the coupling between the metal atoms should then be anti-ferro magnetic. Hence the spin should point down.

The coupling is stronger for strong chemical bonds. When the octahedrons are rotated, then the orbital overlap will be smaller and the magnetic exchange decreases. The transition temperature will also decrease.

Task 4: Dielectric materials (13%).

a) How does one classify the isolating materials in subgroups?

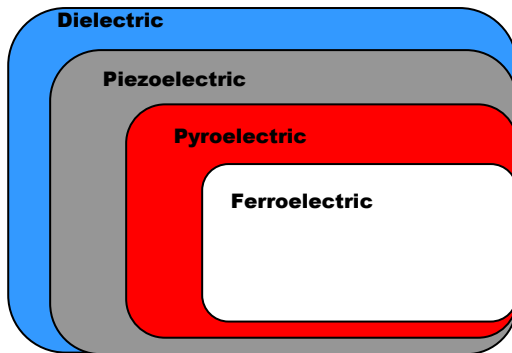

b) What is the difference between a purely piezoelectric and a ferroelectric material? Describe shortly.

A ferroelectric material maintains its electrical moments after an external electric field is switched off. A purely piezoelectric material does not.

c) What types of mechanism / effects occurs in a dielectric material when an external electric field is applied? In other words, what is being polarized in the material? Mention shortly.

- Electrons are polarised
- Ions are polarized out of their position
- Dipole molecules are rotated
- Charged species are diffused through the bulk as space charge

What is the relative importance of these effects as the frequency of the external field is varied? On other words, rate the effects to their response in time.

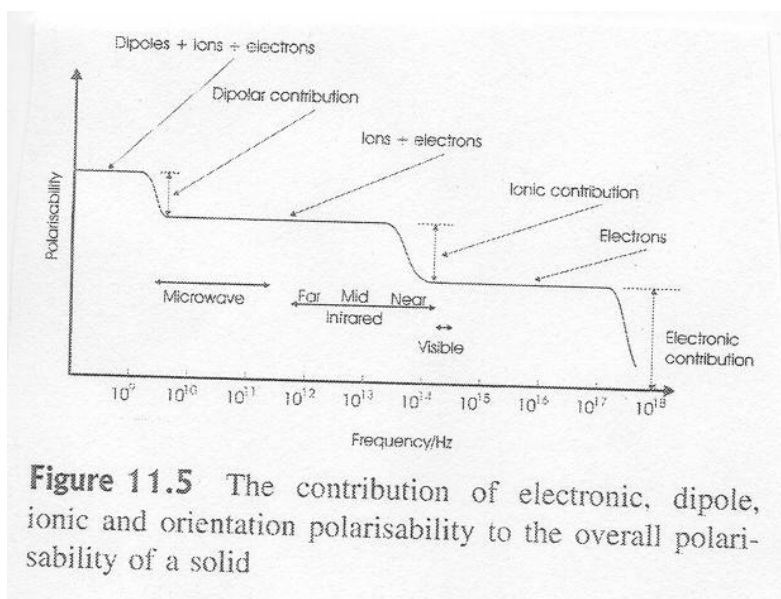

d) What is pooling of a material? Describe shortly.

Orientation of the electrical moments by application of a large external electric field. The sample is usually heated up and let cool under this external field.

Task 5: Diffusion, conduction and optical aspects (30%).

- a) Hydrogen is diffusing through a Pd:Ag membrane at 400 °C. On one side of the membrane we have a gas mixture containing H₂ at a constant pressure and composition. At the other side, H₂ is consumed by a motor running on hydrogen at constant speed, leaving the concentration on that side equal to zero. The system has been running for a long time. Below is a figure which shows four alternatives for how the concentration, C, varies through the thickness, x, of the membrane. (The stippled line indicates the extent of the membrane)

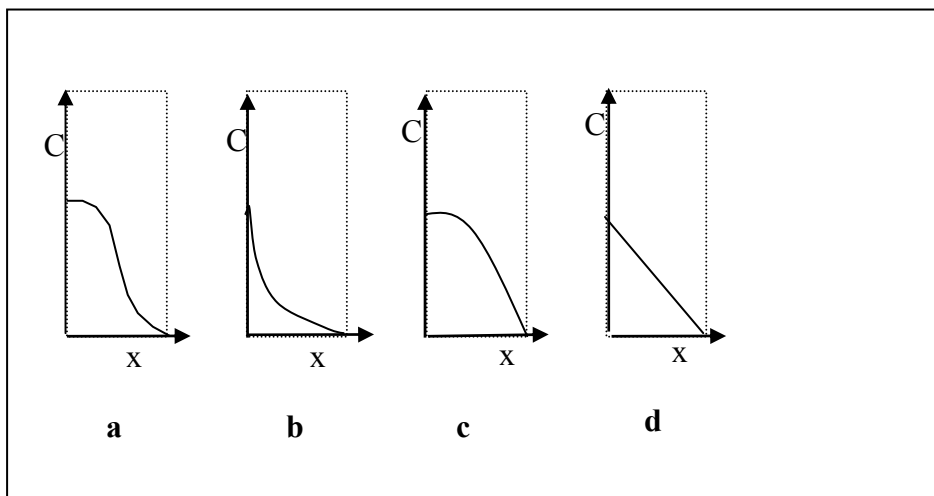

Pick the correct concentration profile and explain why you chose it.

Curve d) is correct. It is the only one that gives a flux which is independent of position, which is required for a stable steady flow situation. Since the motor is running at constant speed and has done so over a long time we have a constant flux of hydrogen. From Ficks 1st law $J = -D \frac{dC}{dx}$ we see that the flux is a constant when the concentration gradient is constant.

- b) A student wants to do an experiment with single photons to study the optical properties of a new type of material she has synthesized. She has a laser with a wavelength 435 nm and an output light power of 0.1 mW. She first needs to adjust the intensity so that she can detect single photons. She has a very sensitive detector, giving an output pulse for every photon. In order that the signals don't overlap in time and can be counted, the counting rate has to be smaller than 10 kHz. She can adjust the counting rate by letting the laser beam go through a glass material with an absorption coefficient of 10⁴ m⁻¹. How thick should the glass be?

Hint: You will need to use the physical constants of the table attached at the end of the problem set.

The single photon energy E is

$$E = h\nu = \frac{hc}{\lambda} = 2.848 \text{ eV},$$

where h is Planck's constant, λ and c the wavelength and velocity of light, respectively.

The number of photons per second the laser emits is given by

$$N_{hv_0} = \frac{I_{hv}}{E}$$

where I_{hv} is the power of the laser in [J/s] and E is the photon energy in [J]. By passing through a thickness x of the material, some of the light intensity is absorbed, i.e. some of the photons are absorbed. We let $N_{hv}(x)$ be the number of photons per unit time after the laser beam has passed through a thickness x of the material. From the definition of the absorption coefficient, α , or Lambert's law, divided by E , we have

$$N_{hv}(x) = N_{hv_0} \exp(-\alpha x)$$

The counting rate of the photons needs to be below 10 kHz, so we must have

$N_{hv}(x) \leq 10 \text{ kHz}$. Thus we must have

$$N_{hv_0} \exp(-\alpha \cdot x) \leq 10 \text{ kHz} \quad \Rightarrow \quad x \geq \frac{1}{\alpha} \ln\left(\frac{N_{hv_0}}{10 \text{ kHz}}\right)$$

Substituting numbers gives $x \geq 2.4 \times 10^{-4} \text{ m} = 240 \text{ } \mu\text{m}$

=====

- c) Describe briefly the geometric structure of amorphous silica (formulae SiO_2).

Amorphous SiO_2 has no long range order of atoms. It is described as a random network of tetrahedral units of SiO_4 . So it has short range order with a distribution of distances and angles between nearest neighbor atoms.

- d) Which are the material(s) of an optical communication fibre?

Which material parameters relate to the signal attenuation in an optical fibre, and which physical and chemical processes are important?

See the textbook page 457 for a description of optical fibers.

The material for optical fiber is silica. The core and cladding is usually Ge doped silica, SiO_2 . Then there is a plastic sleeve.

The optical fiber is a waveguide yielding total internal reflection because of. Ideally there is no loss of the light that is guided by total internal reflection. A difference in the refractive index between the core and cladding accomplishes that. (The sleeve is for protection)

In real life there is absorption and scattering in the fiber which cause a signal attenuation. Rayleigh scattering occurs from small inhomogeneities in the glass composition. Then there is absorption by phonons in the SiO_2 network. In addition there is absorption by impurities, notably hydroxyl – OH but also ppm levels or below of metallic impurities.

- e) Consider the semiconductor $\text{Si}_{0.9}\text{Ge}_{0.1}$. Draw schematically how the Fermi level will vary with temperature. Include the position of the conduction band and valence band in the diagram and comment on the low temperature and high temperature limits.

The problem does not specify if there are any impurities in the semiconducting material. It would thus suffice to describe how the Fermi level will vary for an undoped intrinsic semiconductor. Completely pure materials can not be realized in reality, so we could also specify how the Fermi level will vary for n-type and/or p-type material.

Below is sketched how the Fermi level varies with temperature. The indicated energies are E_C , E_V conduction and valence band edges, E_A and E_D acceptor and donor levels

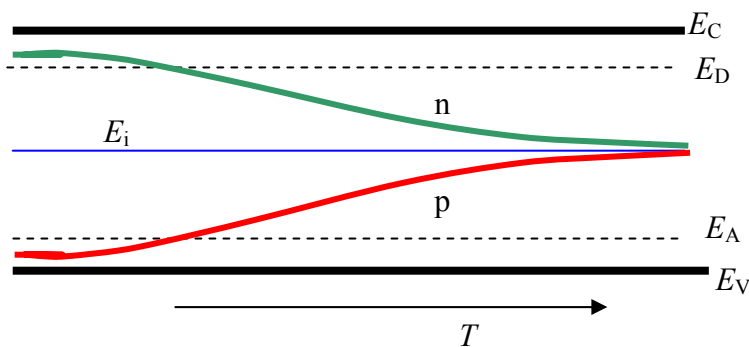

The blue curve is the intrinsic Fermi level. It varies only little with temperature, and is close to the middle of the band gap. [If we want to explain that, we can say that the number of electrons and holes are always the same in the intrinsic case and because of the symmetry property of the Fermi Dirac function; $f(E-E_F)=1-f(E_F-E)$, the intrinsic Fermi level, E_F , is close to the middle of the band gap, when the density of states in the valence band is of the same order of magnitude as that in the conduction band]

The green curve shows the situation for n-type. At $T=0$, E_F must be above the highest occupied energy level, which is at E_D . So $E_F > E_D$. Further, since there are no free electrons at $T=0$ we must have $E_F < E_C$. Upon heating, electrons are excited from the donor level and we get more free electrons as the temperature increases. At some temperature half of the donor levels are ionized. Then $E_F = E_D$ (assuming no degeneracy of the level) since $f(E_F) = 1/2$. At high temperatures electrons are excited from the valence band also and the number of holes increases. We get equal number of holes and electrons in the high temperature limit. Then the material is intrinsic and $E_F = E_i \approx E_g / 2$.

The p-type material case is drawn with red. It is analogous to that for n-type except that of course the highest level occupied at $T=0$ is the valence band maximum. At increasing temperature holes are excited.

Candidate number:

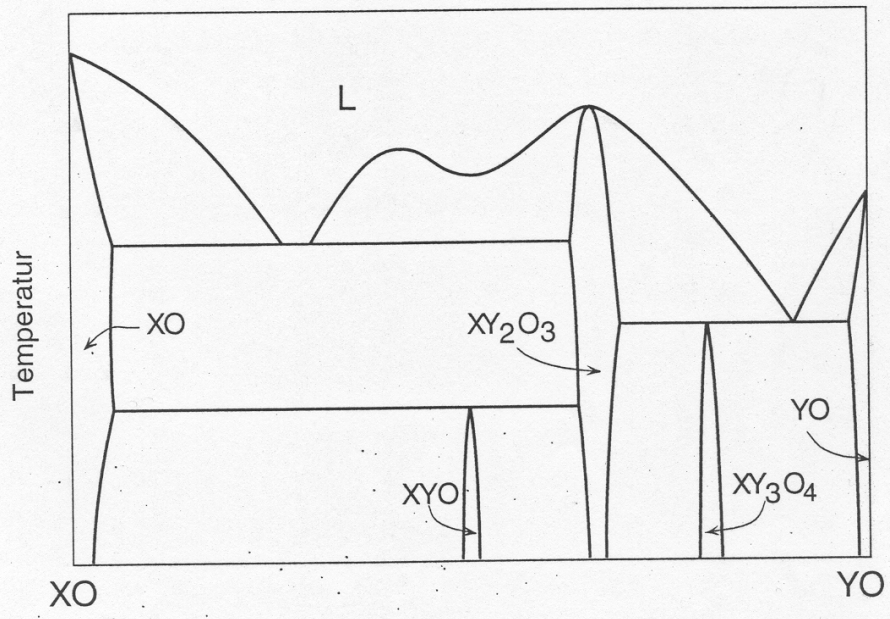

Figur 3: Fasediagram med feil (eller usannsynlige faseforhold).

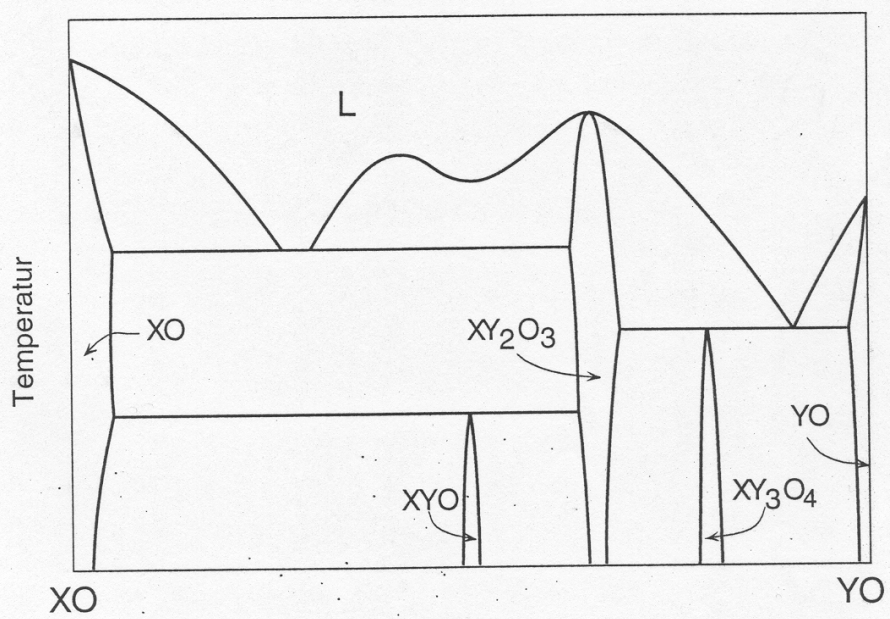

Figur 3: Fasediagram med feil (eller usannsynlige faseforhold).

Kandidatnummer:
Candidate number:

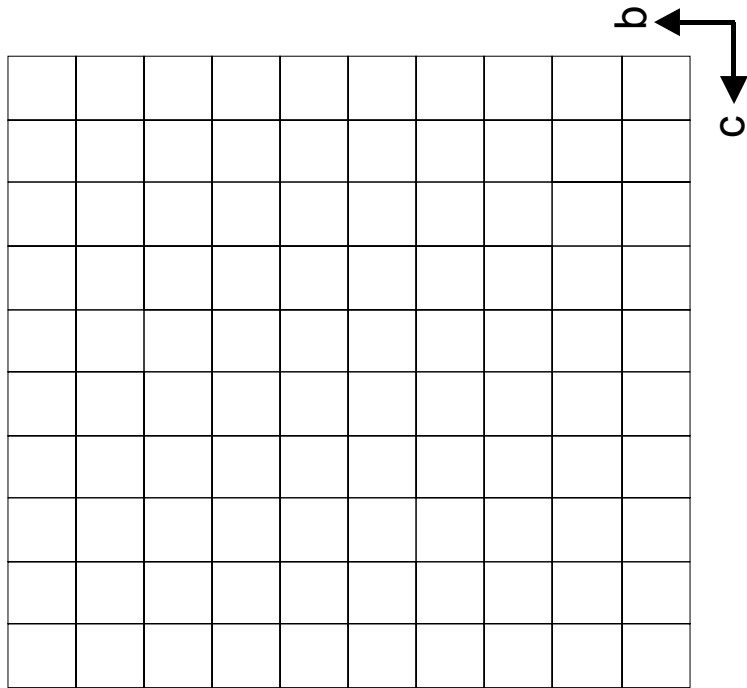
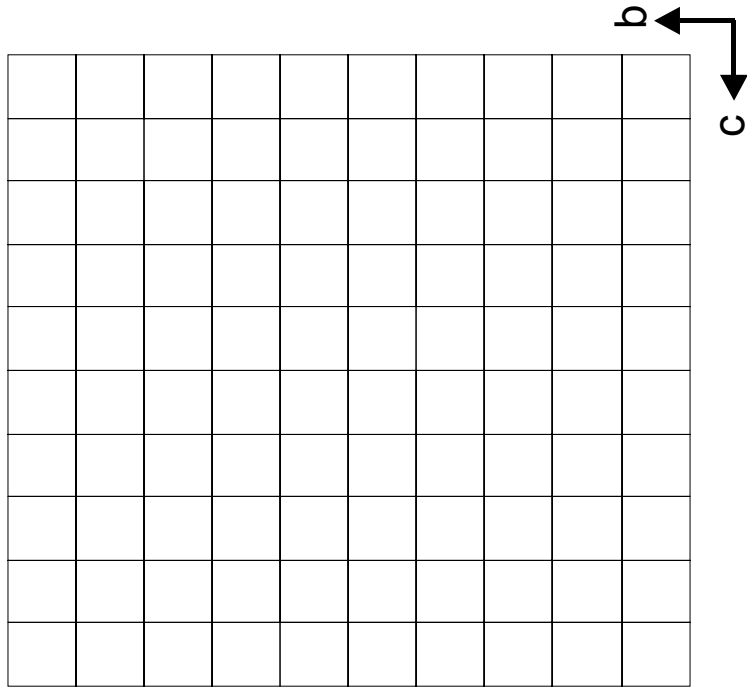

Conversion factors and other relationships

atmosphere (atm): $1(\text{atm}) = 101.325 \text{ kPa}$

electron volt (eV): $1(\text{eV}) = 96.485 \text{ kJ mol}^{-1}$
 $(\text{eV}) \times 1.60218 \times 10^{-19} \rightarrow (\text{J})$
 $(\text{J}) \times 6.24150 \times 10^{18} \rightarrow (\text{eV})$

atomic mass unit (u): $1(\text{u}) = 9.31494 \times 10^8 \text{ eV}$
 electron mass = $5.48580 \times 10^{-4} \text{ u}$
 neutron mass = 1.00866 u
 proton mass = 1.00728 u

calorie (cal): $1(\text{cal}) = 4.184 \text{ J}$

$RT = 2.4790 \text{ kJ mol}^{-1}$

$RT/F = 25.693 \text{ mV}$

$hc = 1.98645 \times 10^{-25} \text{ J m}$

Constants

Quantity	Symbol	Value	Units
atomic mass unit	$u = m[^{12}\text{C}]/12$	1.66054×10^{-27}	kg
Avogadro constant	N_A	6.02214×10^{23}	mol^{-1}
Bohr magneton	$\mu_B = eh/4\pi m_e$	9.27402×10^{-24}	J T^{-1}
Bohr radius	$a_0 = \epsilon_0 h^2 / \pi m_e e^2$	5.29177×10^{-11}	m
Boltzmann constant	k	1.38066×10^{-23}	J K^{-1}
elementary charge	e	1.60218×10^{-19}	C
electron mass	m_e	9.10939×10^{-31}	kg
Faraday constant	$F = N_A e$	9.6485×10^4	C mol^{-1}
gas constant	$R = N_A k$	8.31451	$\text{J K}^{-1} \text{ mol}^{-1}$
neutron mass	m_n	1.67493×10^{-27}	kg
Planck constant	h	6.62608×10^{-34}	J s
	$\hbar = h/2\pi$	1.05457×10^{-34}	J s
proton mass	m_p	1.67262×10^{-27}	kg
Standard acceleration due to gravity	g	9.80665	m s^{-2}
vacuum permeability	μ_0	$4\pi \times 10^{-7}$	H m^{-1}
vacuum permittivity	ϵ_0	8.85419×10^{-12}	F m^{-1}
velocity of light	c	2.99792×10^8	m s^{-1}