

Lecture Notes
Mek 4320
Hydrodynamic Wave theory

by

Bjørn Gjevik,
Geir K. Pedersen
and Karsten Trulsen

Department of Mathematics
University of Oslo
Summer 2015

Revision history:

January 1989: “Forelesninger i bølgeteori” by Bjørn Gjevik. In Norwegian.

Spring 2007: New material by Geir K. Pedersen added. Revised by Karsten Trulsen. In Norwegian.

Fall 2008: “Lecture notes MEK4320 Hydrodynamic wave theory”
Partial translation to English by Lucy Karpen, Atle Jensen and Karsten Trulsen.

Fall 2010: Additional translation to English by Atle Jensen.

Summer 2015: Revised by Karsten Trulsen.

Contents

1	INTRODUCTION	5
1.1	Characteristic models and terms	6
2	Surface waves in fluids	11
2.1	Boundary conditions at the surface of the fluid	12
2.2	Dispersion relations for linear capillary and gravity waves	16
2.3	Particle Motion in Surface Waves	19
2.4	The Mechanical Energy in Surface Waves	22
2.5	A simple kinematic interpretation of group velocity. Group velocity for surface waves.	28
2.6	The Klein-Gordon equation	33
2.7	Surface waves generated by a local disturbance in the fluid	34
2.8	Stationary phase approximation. Asymptotic expressions of the Fourier integral.	42
2.9	Asymptotic generation of the wave front	45
2.10	Long waves in shallow water	48
2.11	Derivation of nonlinear shallow water equations	57
	2.11.1 Derivation of Boussinesq equations	57
	2.11.2 Derivation of KdV-equation	60
2.12	Viskositetens innvirkning på overflatebølger	61
2.13	Svingninger i basseng	64
3	GENERAL PROPERTIES OF PERIODIC AND NEARLY PERIODIC WAVE TRAINS	69
3.1	Wave kinematics for one-dimensional wave propagation	70
3.2	Hamiltons equations. Wave-particle analogy	73
3.3	Wave kinematics for multi-dimensional wave propagation. Ray theory.	74
3.4	Eikonal-equation and equations for amplitude variation along the rays	78
3.5	Amplitude variation in nearly periodic wave trains	82

4	Trapped waves	87
4.1	Gravity waves trapped by bottom topography	87
4.2	WKB-metoden	91
4.3	Waves trapped by rotational effects. Kelvin waves	93
5	WAVES ON CURRENTS. DOWNSTREAM AND UP- STREAM WAVES. SHIPWAKES. WAVE RESISTANCE.	97
5.1	Downstream and upstream waves	98
5.2	The amplitude for two-dimensional downstream waves	99
5.3	Skipsbølgemønsteret	103
5.4	Wave resistance	113
5.5	Overflatebølger modifisert av strøm som varierer i styrke i horison- tal retning	115
6	INTERNE TYNGDEBØLGER	119
6.1	Interne bølger i inkompressible væsker hvor diffusjonsprosessen kan neglisjeres. Dispersjonsegenskaper og partikkelbevegelse.	120
6.2	Interne bølger knyttet til sprangsjiktet	124
7	NONLINEAR WAVES	129
7.1	Ikke-lineære bølger på grunt vann. Riemann's løsningsmetode. Bølgebrytning.	130
7.2	Korteweg-de Vries equation. Nonlinear waves with permanent form. Solitons.	134
7.2.1	Mer om solitoner	136
7.3	Vannstandssprang. Hydraulisk sjokk.	137
	Bibliography	141

Chapter 1

INTRODUCTION

It is difficult to give a general, and at the same time, precise definition of what wave motion is, but the following loose formulation can be a useful starting point: A wave is a disturbance that can propagate from one part of a medium to another with a characteristic speed. This requires the disturbance to be such that its position can be determined at any given time. The disturbance can change form, size, and propagation speed. Accordingly, both periodic disturbances (wave trains) and isolated disturbances (pulses) that move through the medium can be designated as waves.

Wave motion occurs in fluids, gasses, elastic media, and vacuums, but the waves can have different physical characteristics. Examples include surface waves on water caused by the forces of gravity or surface tension, inertial waves in the ocean and atmosphere caused by Earth's rotation, seismic waves caused by elastic forces, and electromagnetic waves caused by electric and magnetic forces. Even though the causes of wave propagation can be different, the different types of waves share common characteristics and a lot of the mathematical methods which are used in examinations of the various wave phenomena are the same. One can therefore correctly speak of a generic wave theory for all wave forms.

The main purpose of this lecture series is to describe important forms of wave propagation in fluids. We shall not seek to give a complete description of all wave types. Instead, we shall make the selection so that we get to common traits in different types of waves, and we seek to select them such that we get to know the essential mathematical methods in wave theory. For a more complete treatment of the field, refer to the books by Lamb (1932), Stoker (1957), Tolstoy (1973), Whitham (1974), and Lighthill (1978).

1.1 Characteristic models and terms

The simplest mathematical model for wave propagation is given by the equation

$$\frac{\partial \phi}{\partial t} + c \frac{\partial \phi}{\partial x} = 0 \quad (1.1)$$

where x is a spatial coordinate, t is time c is a constant. This equation has the solution

$$\phi = f(x - ct)$$

where f is an arbitrary function that describes a disturbance that moves along the x -axis with constant speed c .

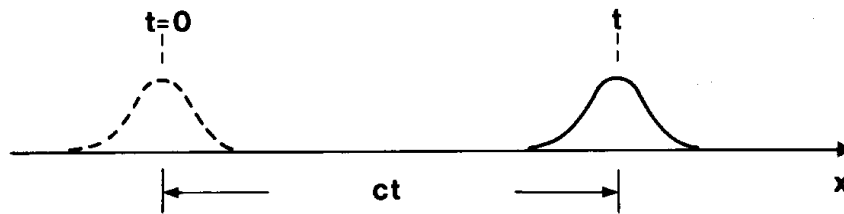

Figure 1.1: One-dimensional wave propagation.

The three-dimensional wave equation

$$\frac{\partial^2 \phi}{\partial t^2} - c^2 \nabla^2 \phi = 0 \quad (1.2)$$

can describe propagation of sound waves, seismic waves, and electromagnetic waves in a medium with constant propagation speed c .

One solution of (1.2) is the spherically symmetric wave which can be written as

$$\phi = \frac{f(r - ct)}{r} + \frac{g(r + ct)}{r} \quad (1.3)$$

where r is the distance from a fixed reference point O in space. Here f and g are arbitrary functions describing disturbances that propagate out from or toward O , respectively. Notice that this wave attenuates with a factor $1/r$ because the energy is spread over continuously larger spherical shells (spherical attenuation) as r increases.

Another solution of (1.2) is the plane wave which can be written as

$$\phi = A \exp\{i(\mathbf{k} \cdot \mathbf{r} - \omega t)\} \quad (1.4)$$

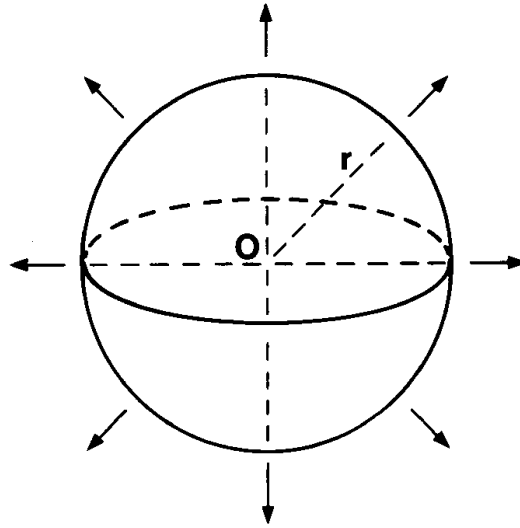

Figure 1.2: Spherically symmetric wave propagation.

where A can be called the complex wave amplitude. Sometimes we want the solution to be real, then we can write

$$\phi = \frac{A}{2} \exp\{i(\mathbf{k} \cdot \mathbf{r} - \omega t)\} + \text{c.c.} = |A| \cos(\mathbf{k} \cdot \mathbf{r} - \omega t + \arg A) \quad (1.5)$$

where A is complex and c.c. denotes “complex conjugate of the previous expression”. Here $|A|$ can be called the real wave amplitude and $\arg A$ is a phase lag.

The other two constants ω and \mathbf{k} above are related by the so-called dispersion relation, which for the wave equation (1.2) is

$$\omega^2 = (\mathbf{k}c)^2. \quad (1.6)$$

The vector \mathbf{r} is a position vector relative to the reference point O , in a Cartesian coordinate system we have $\mathbf{r} = (x, y, z)$. The scalar

$$\chi = \mathbf{k} \cdot \mathbf{r} - \omega t \quad (1.7)$$

is called the *phase function*. The equation

$$\chi = \chi_0 = \text{constant}$$

describes how locations of constant phase move through space and time. If the phase function is held constant at a given time it defines a plane that can be called a *phase plane*. A trough or a crest corresponds to fixed values of the phase

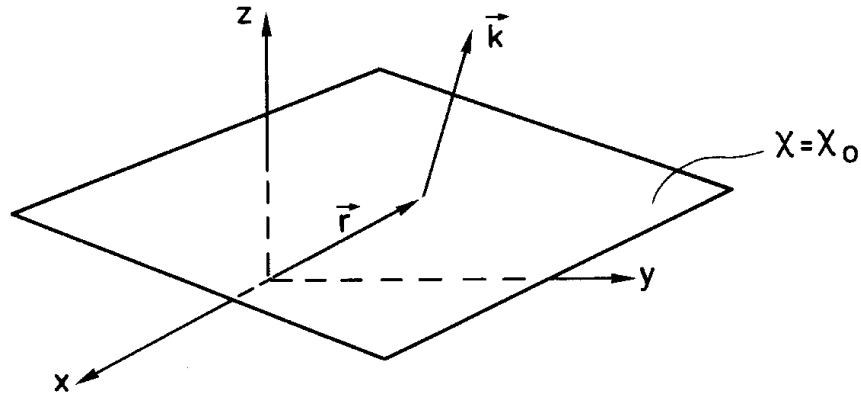

Figure 1.3: Phase plane.

function. The vector \mathbf{k} is the *wavenumber vector*, or simply the *wave vector*, and the components along the axes x , y and z are, respectively, designated k_i ($i = 1, 2, 3$) or k_x , k_y and k_z . It follows from (1.7) that

$$\mathbf{k} = \nabla\chi \quad (1.8)$$

which shows that the wave vector is orthogonal to the phase plane.

The *wavelength* λ is the distance between two phase planes for which the phase function changes by 2π . We have

$$\lambda = \frac{2\pi}{k} \quad (1.9)$$

where $k = |\mathbf{k}|$ is the *wavenumber*. The *angular frequency* is ω . The *period* T and *frequency* f are given by

$$\begin{aligned} T &= \frac{2\pi}{\omega} \\ f &= \frac{1}{T} \end{aligned} \quad (1.10)$$

The ratio between angular frequency and wavenumber

$$c = \frac{\omega}{k} \quad (1.11)$$

is known as the *phase speed*. For the wave equation (1.2) it is seen that the phase speed coincides with the speed c appearing in the equation (1.2). Since c is in this case independent of \mathbf{k} and ω , we say that these waves are *non-dispersive* or *dispersionless*.

The phase speed is the speed that the phase plane moves in the normal direction, *i.e.* in the direction of the wave vector \mathbf{k} . However, in a direction different

from \mathbf{k} the phase plane moves faster than the phase speed (see relevant exercise below). Thus the phase speed does not satisfy the principles of vector projection, it is not a vector¹ and should not be called a velocity.²

For the linear equations (1.1) and (1.2) the principle of superposition is valid: A sum of the solutions of the form (1.4) or (1.5) is also a solution of the wave equation. By means of Fourier series or Fourier transform we can derive plane waves of arbitrary form.

The wave equation (1.2) appears quite frequently upon making simplifying assumptions on the nature of wave propagation and the medium, typical assumptions are:

1. Small amplitude such that the governing equations can be linearized.
2. Wave energy is conserved.
3. The medium is homogeneous and stationary.

In many applications these assumptions will not be fulfilled. Examples are nonlinear waves and waves in inhomogeneous media — topics of great current research interest. Through examples we shall show important properties of such wave phenomena.

In elementary expositions of wave theory the impression is often given that wave propagation is limited to hyperbolic equations of the type (1.1) or (1.2). This is not correct. One of the most conspicuous forms of waves, namely surface waves on water, are not of this type. Water waves belong to the class of *dispersive waves*, and for these waves, the phase speed depends on the wavelength. Dispersive waves can be plane waves like equation (1.4), but the dispersion relation is different from equation (1.6). In the general case ω is both dependent on the magnitude and the direction of the wave vector, and we can write the *dispersion relation* as

$$\omega = \omega(\mathbf{k}). \quad (1.12)$$

In many cases the dispersion relation is *isotropic*. This entails that ω is independent of the direction of the wave vector, and depends only on the wavenumber such that

$$\omega = \omega(k). \quad (1.13)$$

With isotropic dispersion, the phase speed is independent of the orientation of the phase plane.

With *anisotropic* dispersion the phase speed will be different depending on the orientation of the phase plane. Examples of this are elastic waves in sedimentary layers and ocean surface waves that propagate in areas of non-uniform currents.

¹By *velocity* (Norwegian: *hastighet*) we mean a vector. By *speed* (Norwegian: *fart*) we mean a scalar. For a quantity to be a vector, it must satisfy the principles of vector projection.

²Despite these concerns, some authors *define* the phase velocity to be a vector with the same direction as \mathbf{k} , e.g. Whitham (1974) page 365.

Exercises

1. The dispersion relation.

Which of these equations have solutions of the form $\eta = A \exp\{i(\mathbf{k} \cdot \mathbf{r} - \omega t)\}$? Find and describe the dispersion relation, *i.e.* the relation between ω and \mathbf{k} . Which of these equations support waves?

$$(a) \quad \frac{\partial^2 \eta}{\partial t^2} = c_0^2 \frac{\partial^2 \eta}{\partial x^2}$$

$$(b) \quad \frac{\partial \eta}{\partial t} = c_0^2 \frac{\partial^2 \eta}{\partial x^2}$$

$$(c) \quad \frac{\partial \eta}{\partial t} = c_0 \frac{\partial \eta}{\partial x} + \epsilon \frac{\partial^3 \eta}{\partial x^3}$$

$$(d) \quad \frac{\partial^2 \eta}{\partial t^2} + a \frac{\partial \eta}{\partial t} = c_0^2 \frac{\partial^2 \eta}{\partial x^2}$$

$$(e) \quad \frac{\partial^4 \eta}{\partial t^4} - \frac{\partial^4 \eta}{\partial t^2 \partial x^2} + \epsilon \frac{\partial^4 \eta}{\partial x^4} = 0$$

$$(f) \quad \frac{\partial^2 \eta}{\partial t^2} = \nabla^2 \eta + \frac{\epsilon}{3} \nabla^2 \frac{\partial^2 \eta}{\partial t^2}$$

$$(g) \quad \frac{\partial^2 \eta}{\partial t^2} = \frac{\partial}{\partial x} \left(x \frac{\partial \eta}{\partial x} \right)$$

$$(h) \quad \frac{\partial}{\partial x} \left(\frac{\partial \eta}{\partial t} + \frac{\partial \eta}{\partial x} + \frac{\mu^2}{6} \frac{\partial^3 \eta}{\partial x^3} \right) + \frac{1}{2} \frac{\partial^2 \eta}{\partial y^2} = 0$$

2. Standard wave equations and initial conditions.

A function η is defined for all x and satisfies the equation given in exercise 1a. How many initial conditions are needed to ensure a unique solution? Give an example of such a set of initial conditions. Find the solution at an arbitrary later time. Repeat for 1c with $\epsilon = 0$. Discuss the case $\epsilon \neq 0$.

3. Standard wave equation in spherical coordinates.

Express the Laplace operator ∇^2 in spherical coordinates $\{r, \theta, \varphi\}$, and show that equation (1.3) is a solution of equation (1.2).

Hint: Avoid confusing the unknown ϕ and the azimuthal angle φ .

4. Practical exercise for phase speed.

Next time you go to the coast, find a long pier that does not obstruct the water surface waves below. Suppose the waves are longcrested and have wave vector pointing in the x -direction, *i.e.*, crests aligned in the y -direction. Suppose the pier is oriented at an angle θ with the x -axis. You want to run along the pier such that you follow one particular crest. Show that you need to run at a speed $c/\cos\theta$ where c is the phase speed of the waves. How fast would you have to run if the crest is parallel to the pier?

Chapter 2

Surface waves in fluids

Surface waves caused by gravity or surface tension is perhaps one of the most well recognized day to day phenomena. This form of wave motion has been described and studied in numerous scientific works, and they have shown that surface waves have a multitude of properties, which, in many cases, can be found also in other forms of wave theory. It follows that surface waves take a central place in wave theory.

Depending on whether surface tension or gravity dominates for the wave motion, we use the terms *capillary waves* or *gravity waves*. In some cases, wave motion will be influenced just as much by surface tension as by gravity. We use the term *capillary-gravity waves* for these waves. Both capillary and gravity waves will be under the influence of the viscosity in the fluid such that the shortest waves are the ones that are dampened the most by the effect of friction. For wave motion in deep water, the viscosity leads to substantial dampening only for waves with a wavelength of less than about 1 cm. Compressibility in the fluid will generally be insignificant for surface waves.

Surface waves are closely related to waves that operate on the boundary between fluids of different densities. Some examples of this will be given in the section on internal waves.

2.1 Boundary conditions at the surface of the fluid

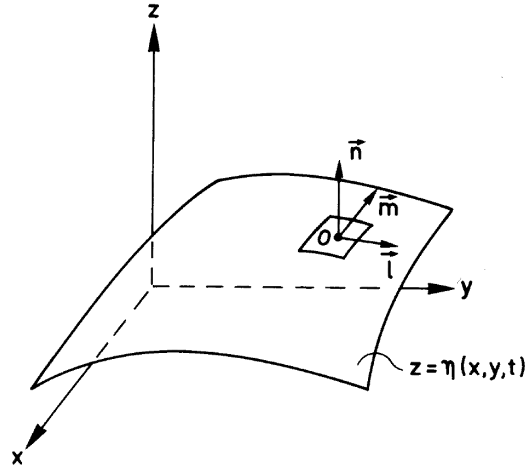

Figure 2.1: Orthogonal unit vectors on the surface

In the following, we often find use for the mathematical expression of boundary conditions at the surface of the fluid, and initially, we will derive these. Here we shall handle the case where a fluid borders an overlaying gas with much smaller density than the fluid such that one can neglect the motion in the overlaying gas. Because of that, we can expect the pressure over the fluid to be a constant isotropic pressure, which we designate as p_a .

We let $z = \eta(x, y, t)$ define the surface. The z -axis is in the vertical direction pointing up and the x - and y -axes are horizontal. We view the fluid as filling the space under the surface. When the fluid is stationary, and in equilibrium, the surface lies on the xy -plane. The unit normal vector \mathbf{n} defines the surface normal at point O . This is chosen such that the unit vector points up from the surface. The unit vectors \mathbf{l} and \mathbf{m} lay in the tangent plane at point O , and the vectors \mathbf{l} , \mathbf{m} and \mathbf{n} constitute a set of orthogonal unit vectors. Such a set is given for example by

$$\begin{aligned}
 \mathbf{l} &= (0, 1, \alpha_2) / \sqrt{1 + \alpha_2^2} \\
 \mathbf{m} &= (-\alpha_2^2 - 1, \alpha_1 \alpha_2, -\alpha_1) / \sqrt{(1 + \alpha_1^2 + \alpha_2^2)(1 + \alpha_2^2)} \\
 \mathbf{n} &= (-\alpha_1, -\alpha_2, 1) / \sqrt{1 + \alpha_1^2 + \alpha_2^2}
 \end{aligned} \tag{2.1}$$

For a simplified writing, we have introduced the notation $\alpha_i = \partial\eta/\partial x_i$, where $i = 1, 2$ designate, respectively, x and y .

Below a surface element with area dA which lies in the surface with point O at its center (see fig. 2.1), forces act due to pressure and viscous stress in the fluid. With the assumptions we have made here there is also a pressure force acting on top of the surface element. The sum of these forces can be written as

$$[(p - p_a)\mathbf{n} - \mathbf{n} \cdot \mathcal{P}]dA \quad (2.2)$$

where \mathcal{P} is the viscous stress tensor.

Along the edge of the surface element, additional forces act due to surface tension σ (force per unit of length), oriented along the tangent to the surface at the edge of the surface element. Let the point O be contained in a simply connected area Ω on the surface, limited by the edge Γ . The capillary force which acts on a linear line segment $d\mathbf{s}$ can be written as $-\sigma\mathbf{n} \times d\mathbf{s}$, where \mathbf{n} is the surface normal for the line segment $d\mathbf{s}$. The total capillary force acting on the edge Γ of the surface element is

$$\mathbf{F} = - \oint_{\Gamma} \sigma\mathbf{n} \times d\mathbf{s}.$$

In the case that σ is constant on the surface, we can with the help of Stokes theorem, and with a view that the boundary $\Omega \rightarrow dA$ shrinks in towards the point O , show that the capillary force on the surface element is in the direction of the normal vector \mathbf{n} at O , and is given by

$$d\mathbf{F} = \mathbf{n} dF_n = -\sigma\mathbf{n} \nabla \cdot \mathbf{n} dA.$$

The magnitude of the resultant capillary force can alternatively be expressed by the principal radii of curvature for the surface. In figure 2.2, the surface element is chosen such that the edges ds_1 and ds_2 fall along the principal directions of curvature for the surface. In the figure, we designate S_1 and S_2 the centers of curvature and R_1 and R_2 the principal radii of curvature for the surface. The angles $d\beta_1$ and $d\beta_2$ are given by the relations

$$d\beta_1 = \frac{ds_1}{R_1} \quad \text{and} \quad d\beta_2 = \frac{ds_2}{R_2}.$$

We find therefore that

$$F_n = -2\sigma ds_2 \frac{d\beta_1}{2} - 2\sigma ds_1 \frac{d\beta_2}{2} = -\sigma \left(\frac{1}{R_1} + \frac{1}{R_2} \right) dA \quad (2.3)$$

where R_1 and R_2 are chosen positive when the corresponding curvature centers are positioned inside the fluid. The quantity $\frac{1}{2} \left(\frac{1}{R_1} + \frac{1}{R_2} \right)$ is commonly called the mean curvature.

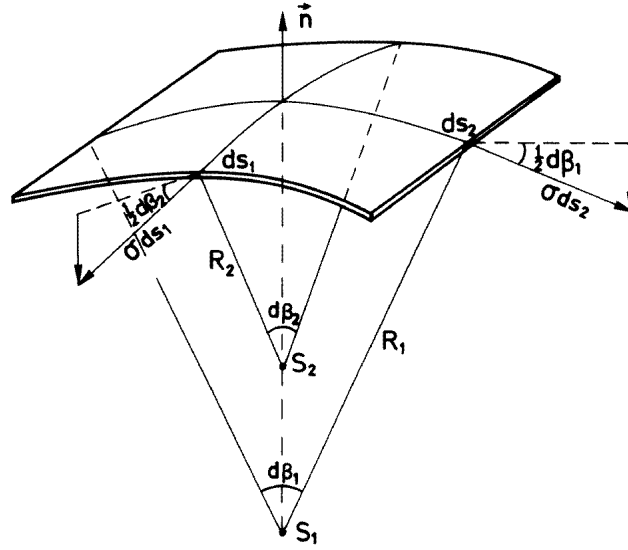

Figure 2.2: Principal radii of curvature for the surface

To avoid that the fluid particles at the surface are exposed to infinitely (or unrealistically) large accelerations, the resultant forces of the pressure and gravity must be zero. This leads to the *dynamic boundary conditions* at $z = \eta(x, y, t)$

$$\begin{aligned} p - \mathbf{n} \cdot \mathcal{P} \cdot \mathbf{n} - \sigma \nabla \cdot \mathbf{n} &= p_a \\ \mathbf{n} \cdot \mathcal{P} \cdot \mathbf{l} &= 0 \\ \mathbf{n} \cdot \mathcal{P} \cdot \mathbf{m} &= 0 \end{aligned} \quad (2.4)$$

In addition to the requirements (2.4) we impose the kinematic boundary condition at the surface. Normally, mass transport through the surface due to evaporation or diffusive processes is insignificant, and one can with good approximation assume that the fluid particles in the surface move tangentially (or are at rest) in relation to the surface. Given the vector \mathbf{v} with components u , v and w designated the velocity in the fluid, and dt a small time interval, so it follows that the fluid particles at the surface have motion such that

$$z + w dt = \eta(x + u dt, y + v dt, t + dt)$$

With Taylor expansion in powers of dt , we find the *kinematic boundary condition* at the surface.

$$w = \frac{\partial \eta}{\partial t} + \mathbf{v} \cdot \nabla \eta \quad (2.5)$$

The equations (2.4) and (2.5) are nonlinear and the variables u , v , w and η are included in a complicated fashion. We shall therefore treat some special cases and show how the boundary conditions simplify by linearization.

Given that one can assume the fluid motion is irrotational, the flow velocity can be deduced from a potential ϕ and

$$\mathbf{v} = \nabla\phi \quad (2.6)$$

If the fluid in addition is frictionless and homogeneous, the pressure in the fluid is given by Euler's pressure equation

$$p = -\rho \left(\frac{\partial\phi}{\partial t} + \frac{1}{2}\mathbf{v}^2 + gz \right) + p_a + f(t)$$

where ρ is the density of the fluid and g is the acceleration due to gravity. Here $f(t)$ is an arbitrary function of t . Looking at (2.6) it can be seen that a given velocity field \mathbf{v} can be represented by various potentials ϕ by adding an arbitrary function of time to the potential. We get rid of $f(t)$ by drawing it into ϕ without change in the velocity field. The pressure at the surface can therefore be written

$$p = -\rho \left(\frac{\partial\phi}{\partial t} + \frac{1}{2}\mathbf{v}^2 \right)_{z=\eta} - \rho g\eta + p_a \quad (2.7)$$

By Taylor expansion of the expression in parenthesis in powers of η , we get

$$p = -\rho \left[\left(\frac{\partial\phi}{\partial t} \right)_{z=0} + g\eta \right] - \rho \left[\frac{\partial^2\phi}{\partial t\partial z}\eta + \frac{1}{2}\mathbf{v}^2 \right]_{z=0} + \dots + p_a \quad (2.8)$$

where \dots designates higher order terms in the series.

Given that the wave amplitude is small enough, without us being able to define precise orders of magnitude, the terms where the flow variables (η, ϕ, \mathbf{v}) occur to quadratic or higher order may be dropped in relation to the terms which are linear in the flow variables. After we have found the wave motion that satisfies the linearized equations, we can set these linear solutions inside the nonlinear terms. From this we can find an estimate for how small the amplitude must be for the higher order terms to be dropped. We shall come back to this at a later point.

The linearized expression for pressure at $z = \eta$ can be written

$$p = -\rho \left[\left(\frac{\partial\phi}{\partial t} \right)_{z=0} + g\eta \right] + p_a \quad (2.9)$$

One can proceed similarly to linearise the terms that acts in the boundary conditions (2.4). The expression where surface tension is included can be written

$$-\sigma\nabla \cdot \mathbf{n} = \sigma \frac{\eta_{xx}(1 + \eta_y^2) + \eta_{yy}(1 + \eta_x^2) - 2\eta_x\eta_y\eta_{xy}}{(1 + \eta_x^2 + \eta_y^2)^{3/2}}$$

such that one can, by linearization find

$$-\sigma \nabla \cdot \mathbf{n} = \sigma \left(\frac{\partial^2 \eta}{\partial x^2} + \frac{\partial^2 \eta}{\partial y^2} \right). \quad (2.10)$$

Exercises

1. Consult the book or the compendium in MEK3220 to review the full expression for the viscous stress tensor \mathcal{P} .
2. Find the linear expression for the viscous stress components in (2.4). Assume Newtonian fluids.
3. Find, by expansion, the linear and quadratic terms in the kinematic boundary condition (2.5).

2.2 Dispersion relations for linear capillary and gravity waves

We shall consider two-dimensional surface waves in a frictionless, homogeneous, and incompressible fluid restricted with a flat and horizontal bottom. We place

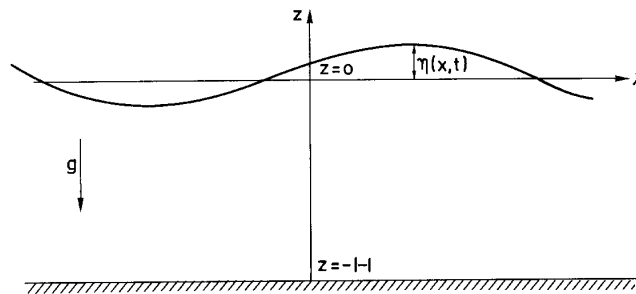

Figure 2.3: Two-dimensional wave

the axes such as is shown in figure 2.3 where the x -axis forms the surface when the fluid is at rest and equilibrium. The depth of the fluid layer is then H .

As the wave motion is supposed to be irrotational and the fluid is incompressible the velocity potential satisfies the Laplace equation

$$\nabla^2 \phi = 0. \quad (2.11)$$

For linear waves the surface boundary conditions can, in accordance with (2.4), (2.9), (2.10) and results from the exercise under point 3 above, be written

$$\begin{aligned}\frac{\partial\phi}{\partial t} + g\eta - \frac{\sigma}{\rho}\frac{\partial^2\eta}{\partial x^2} &= 0 \\ \frac{\partial\phi}{\partial z} &= \frac{\partial\eta}{\partial t}\end{aligned}\quad (2.12)$$

for $z = 0$. In addition to these conditions comes the boundary conditions on the bottom, $z = -H$

$$\frac{\partial\phi}{\partial z} = 0. \quad (2.13)$$

The monochromatic wave solution of the equations (2.11)–(2.13) can be written

$$\begin{aligned}\eta &= a \sin(kx - \omega t) \\ \phi &= -\frac{a\omega}{k \sinh kH} \cosh k(z + H) \cos(kx - \omega t)\end{aligned}\quad (2.14)$$

where a is the amplitude of the wave. The wavenumber and angular frequency are connected by the dispersion relation

$$\omega^2 = \left(gk + \frac{\sigma k^3}{\rho}\right) \tanh kH. \quad (2.15)$$

The phase speed for capillary–gravity waves is therefore given by

$$c = c_0 \left(1 + \frac{\sigma k^2}{\rho g}\right)^{\frac{1}{2}} \left(\frac{\tanh kH}{kH}\right)^{\frac{1}{2}} \quad (2.16)$$

where $c_0 = \sqrt{gH}$. The equation (2.16) is little affected by surface tension given $\frac{\sigma k^2}{\rho g} \ll 1$. This entails that the surface tension can be neglected for waves with wavelength much larger than λ_m where

$$\lambda_m = 2\pi \left(\frac{\sigma}{\rho g}\right)^{\frac{1}{2}}. \quad (2.17)$$

On the other hand, surface tension dominates wave motion when the wave length is much smaller than λ_m . For clean water at 20°C we have $\sigma = 7.4 \cdot 10^{-2}$ N/m, $\rho = 10^3$ kg/m³, and with $g = 9.81$ m/s² we have $\lambda_m = 1.73$ cm.

In this case where the wavelength is much less than H and thereby $kH \gg 1$ we can with good approximation set $\tanh kH = 1$ and we find from (2.16) that

$$c = \left(\frac{g}{k} + \frac{\sigma k}{\rho}\right)^{\frac{1}{2}}. \quad (2.18)$$

In this case the phase speed has a minimum value

$$c_m = 2^{\frac{1}{2}} \left(\frac{\sigma g}{\rho}\right)^{\frac{1}{4}}$$

for wavelength λ_m . For clean water at 20°C is $c_m = 23$ cm/s. Upon introducing the magnitudes λ_m and c_m we can write (2.18) as

$$\frac{c}{c_m} = \left[\frac{1}{2} \left(\frac{\lambda}{\lambda_m} + \frac{\lambda_m}{\lambda} \right) \right]^{\frac{1}{2}}.$$

We notice that when the wavelength is larger than λ_m , the propagation velocity is larger for long waves than it is for short, but the opposite is true for wavelength less than λ_m . Figure 2.4 shows c as a function of wavelength. Given that the wavelength is much larger than H such that $kH \ll 1$, we can set

$$\tanh kH = kH - \frac{(kH)^3}{3}$$

and we find from (2.16) that

$$c = c_0 \left[1 + \left(\frac{\sigma}{\rho g H^2} - \frac{1}{3} \right) \frac{k^2 H^2}{2} \right]. \quad (2.19)$$

If $\sigma = \frac{1}{3} \rho g H^2$, which for clean water happens for $H = 0.48$ cm, then (2.19) shows that the waves are non-dispersive, in analogy with acoustic waves. Some times, models of water waves are used in experimental studies of non-dispersive sound waves.

With the solutions of the linear equations, which we have found, we are capable of giving complete conditions for the linearization to be valid. Looking back at the solution (2.8), we see that $(\frac{\partial \phi}{\partial t})_{z=0}$ is a typical linear term and $u^2 = (\frac{\partial \phi}{\partial x})_{z=0}^2$ is a typical second order nonlinear term. If we use the solution (2.14), we find that the relation between linear and nonlinear terms is at most

$$\frac{ak}{\tanh kH}.$$

A necessary condition for justifying removal of nonlinear terms and keeping only linear terms is that this ratio be much less than 1. This implies that linearization is valid given that $a/\lambda \ll 1$ when $kH \gg 1$ and $a/H \ll 1$ when $kH \ll 1$. In both cases, linearization would also be valid when the steepness of the wave is adequately small.

Exercises

1. A plane wave has wave vector $\mathbf{k} = (k_x, k_y)$ and angular frequency ω . Give a geometrical/physical interpretation of ω/k_x and ω/k_y . Find the wavenumber, wavelength, and phase speed for a gravity wave in deep water with period 10 s. Find the wave vector when the wave propagates in a direction which is at a 30° angle with the x -axis.

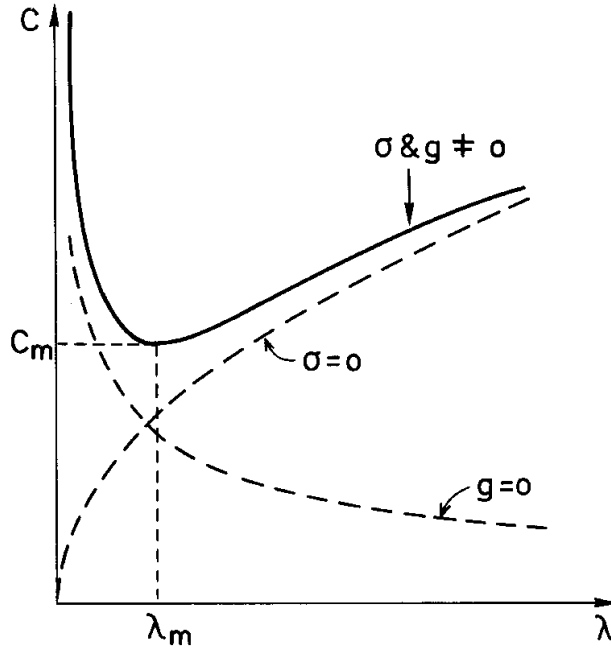

Figure 2.4: Phase speed c as a function of the wavelength λ for waves in deep water.

2. Find the pressure in the fluid for gravity–capillary waves, and determine the pressure at the bottom. How does the pressure vary with z when $kH \ll 1$? Which wave periods can be registered by a pressure sensor that lies on the bottom at 100 m depth with a sensitivity limited to 1/10000 part of the hydrostatic pressure? We let the wave steepness $2a/\lambda$ be 0.1.
3. Determine the kinetic energy density $\frac{\rho}{2}v^2$ for gravity waves in deep water. Which conditions must we set for the wave amplitude a such that the maximum value of the nonlinear term $\frac{\rho}{2}v^2$ is less than 10% of a typical linear term that occurs in Euler's pressure equation? Express this as a condition on the wave amplitude when it is required that the wavelength λ lies between 1 m and 300 m.

2.3 Particle Motion in Surface Waves

Let us at time t_0 designate the fluid particle at position \mathbf{r}_0 such that we can follow its motion. The particle has by a later time a new position \mathbf{r} . The particle velocity follows the velocity field of the fluid \mathbf{v} , and so \mathbf{r} is determined by the following integral equation:

$$\mathbf{r} - \mathbf{r}_0 = \int_{t_0}^t \mathbf{v}(\mathbf{r}, t) dt \quad (2.20)$$

We introduce the particles' displacement \mathbf{R} such that

$$\mathbf{r} = \mathbf{r}_0 + \mathbf{R}$$

and set this expression into the integrand in (2.20). Series expansion in terms of powers of \mathbf{R} gives

$$\mathbf{r} = \mathbf{r}_0 + \int_{t_0}^t \mathbf{v}(\mathbf{r}_0, t) dt + \int_{t_0}^t \mathbf{R} \cdot \nabla \mathbf{v}(\mathbf{r}_0, t) dt + \dots$$

Given that the displacement is small and the velocity gradient is small, higher order terms can be neglected. By linearization we find therefore that

$$\mathbf{R} = \mathbf{r} - \mathbf{r}_0 = \int_{t_0}^t \mathbf{v}(\mathbf{r}_0, t) dt \quad (2.21)$$

We shall use this equation to find the particle motion for two-dimensional capillary and gravity waves. The velocity components in wave motion are according to (2.6) and (2.14)

$$\begin{aligned} u &= \frac{\partial \phi}{\partial x} = \frac{a\omega}{\sinh kH} \cosh k(z+H) \sin(kx - \omega t) \\ w &= \frac{\partial \phi}{\partial z} = -\frac{a\omega}{\sinh kH} \sinh k(z+H) \cos(kx - \omega t) \end{aligned}$$

We set $\mathbf{r}_0 = (x_0, z_0)$ and $\mathbf{r} = (x, z)$, then it follows from (2.21) that

$$\begin{aligned} x - x_0 &= \frac{a}{\sinh kH} \cosh k(z_0 + H) \cos(kx_0 - \omega t) + K_1 \\ z - z_0 &= \frac{a}{\sinh kH} \sinh k(z_0 + H) \sin(kx_0 - \omega t) + K_2 \end{aligned} \quad (2.22)$$

where K_1 and K_2 are integration constants.

Both here and later we will need the time-average of a function $F(t)$, and we define this by

$$\bar{F}(t_0) = \frac{1}{T} \int_{t_0 - T/2}^{t_0 + T/2} F(t) dt, \quad (2.23)$$

where t_0 is an indefinite constant. If the function $F(t)$ is periodic with period T , the time average \bar{F} is independent of t_0 .

By time-averaging (2.22) we find, since \cos and \sin are periodic functions,

$$\begin{aligned} \bar{x} - x_0 &= K_1 \\ \bar{z} - z_0 &= K_2 \end{aligned}$$

where (\bar{x}, \bar{z}) is the average position of the particles. With the help of these relations (2.22) can be written

$$\begin{aligned} x - \bar{x} &= A \cos(kx_0 - \omega t) \\ z - \bar{z} &= B \sin(kx_0 - \omega t) \end{aligned} \quad (2.24)$$

where

$$A = a \frac{\cosh k(z_0 + H)}{\sinh kH} \quad \text{and} \quad B = a \frac{\sinh k(z_0 + H)}{\sinh kH}.$$

From (2.24) it follows that

$$\left(\frac{x - \bar{x}}{A}\right)^2 + \left(\frac{z - \bar{z}}{B}\right)^2 = 1 \tag{2.25}$$

which shows us that the water particles follow elliptical paths, and that the orbital period is the wave period $T = 2\pi/\omega$. The semi-axes of the ellipses are A and B . For particles that are near the bottom ($z_0 \rightarrow -H$) it is seen that $A \rightarrow a/\sinh kH$ and $B \rightarrow 0$, and the ellipses degenerate to straight lines. If H is much larger than the wavelength such that $kH \gg 1$, then $A = B = ae^{kz_0}$. In this case, accordingly for waves in deep water, the particle paths are circular such as what is shown in figure 2.5. The radius of the circular paths decreases deeper in the water, and at depth $z_0 = -\lambda$ the radius is a factor of $e^{-2\pi} \simeq 2 \cdot 10^{-3}$ smaller than at the surface. The orbital direction of the particle paths follows from (2.24), and for waves that propagate to the right, the orbital direction is indicated with arrows in figure 2.5. For comparison the particle paths in long waves on shallow water $H/\lambda = 0.15$ are sketched in figure 2.6.

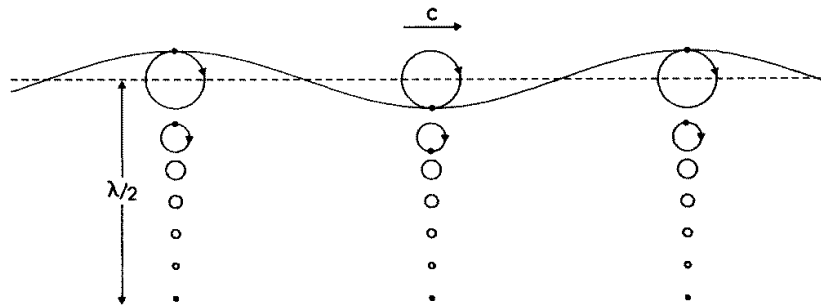

Figure 2.5: Particle paths for waves in deep water $a/\lambda = 0.06$.

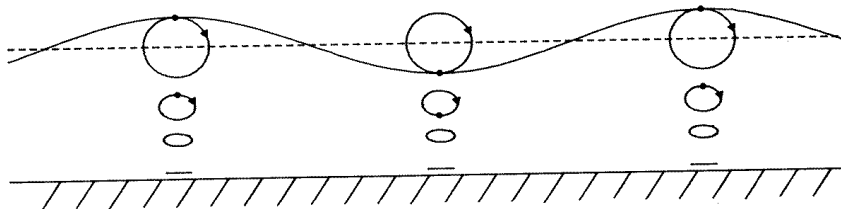

Figure 2.6: Particle paths for waves in shallow water $a/H = 0.25$.

2.4 The Mechanical Energy in Surface Waves

For periodic wave motion, periodic in time with period T , one can find a simple expression for the average mechanical energy per surface area in the horizontal plane. For surface waves, we shall use the term average *energy density* for this quantity. (Normally the term is used for energy per unit of volume.) The energy consists of kinetic and potential energy, and the potential energy in surface waves is caused by surface tension and the force of gravity. When the surface deforms, the surface tension performs work which is σ multiplied by the change in the surface area. The average potential energy per surface area caused by surface tension can therefore be written

$$E_p^k = \frac{1}{T} \int_{t_0}^{t_0+T} \sigma \left[\sqrt{1 + \left(\frac{\partial \eta}{\partial x}\right)^2 + \left(\frac{\partial \eta}{\partial y}\right)^2} - 1 \right] dt$$

Taylor expansion of the integrand gives for small values of $\frac{\partial \eta}{\partial x}$ and $\frac{\partial \eta}{\partial y}$

$$E_p^k = \frac{1}{2T} \int_{t_0}^{t_0+T} \sigma \left[\left(\frac{\partial \eta}{\partial x}\right)^2 + \left(\frac{\partial \eta}{\partial y}\right)^2 \right] dt \quad (2.26)$$

For the *potential energy* due to the force of gravity we chose the zero-level at $z = -H/2$ which is the fluid layer's average height above the bottom. Energy per volume unit is

$$e_p = \rho g \left(z + \frac{H}{2} \right)$$

and the average potential energy per surface area due to the force of gravity can therefore be written as

$$E_p^t = \frac{1}{T} \int_{t_0}^{t_0+T} \int_{-H}^{\eta} e_p dz dt = \frac{\rho g}{2T} \int_{t_0}^{t_0+T} (\eta^2 + H\eta) dt$$

Since the surface displacement η is assumed to be periodic in time, we find

$$E_p^t = \frac{\rho g}{2T} \int_{t_0}^{t_0+T} \eta^2 dt \quad (2.27)$$

The total average potential energy per surface unit for surface waves is

$$E_p = E_p^t + E_p^k \quad (2.28)$$

The *kinetic energy* per volume is

$$e_k = \frac{\rho}{2} \mathbf{v}^2$$

and the average kinetic energy per surface area is

$$E_k = \frac{1}{T} \int_{t_0}^{t_0+T} \int_{-H}^{\eta} e_k \, dz \, dt$$

By Taylor expansion in powers of η we find

$$\int_{-H}^{\eta} e_k \, dz = \int_{-H}^0 e_k \, dz + (e_k)|_{z=0} \eta + \dots$$

For waves with small amplitude it is enough to take the first term in this series expansion, and by introduction of the velocity potential, we can write

$$E_k = \frac{\rho}{2T} \int_{t_0}^{t_0+T} \int_{-H}^0 (\nabla\phi)^2 \, dz \, dt$$

With the help of Green's theorem and the boundary conditions at the bottom (2.13) the expression can be changed, and we find

$$E_k = \frac{\rho}{2T} \int_{t_0}^{t_0+T} \left(\phi \frac{\partial\phi}{\partial z} \right) \Big|_{z=0} \, dt \quad (2.29)$$

Now we set in the expressions (2.14) for velocity potential and surface displacement in (2.26)–(2.29) we find after some simple manipulations

$$\begin{aligned} E_p^k &= \frac{1}{4} \sigma k^2 a^2 \\ E_p^t &= \frac{1}{4} \rho g a^2 \\ E_p &= E_k = \frac{1}{4} \rho g a^2 \left(1 + \frac{\sigma k^2}{\rho g} \right) \end{aligned} \quad (2.30)$$

The last equation shows that the average energy densities of potential and kinetic energy are equal (*equipartition of energy*). Even if this seems to be valid for most types of linear wave motion, it is possible to find examples of wave types where one does not have equipartition of energy: Severdrup-waves, which are a type of gravity–inertia waves, is such an example.

The sum of E_p and E_k is the average mechanical energy density and

$$E = E_p + E_k = 2E_p = 2E_k \quad (2.31)$$

From the last equation in (2.30) it appears that for wavelengths $\lambda \gg \lambda_m$, where λ_m is defined in (2.17), the energy density due to surface tension is insignificant in proportion to the energy density due to gravity. We therefore have that for $\lambda \gg \lambda_m$

$$E = \frac{1}{2} \rho g a^2 \quad (2.32)$$

which is the average mechanical energy density for gravity waves. For wavelengths $\lambda \ll \lambda_m$ the energy density due to gravity is insignificant, and we find that the average mechanical energy density for capillary waves is

$$E = \frac{1}{2} \sigma k^2 a^2 \quad (2.33)$$

We also want to calculate the energy flow or *energy flux* in surface waves. Let us imagine that we limit an area at the water surface WS within a closed curve Γ . Vertically under the surface S lies a volume of water Ω , limited by the vertical wall Π . The total energy in Ω and in WS is given by the expression

$$\int_{\Omega} e_p dV + \int_{\Omega} e_k dV + \int_{WS} \sigma dS$$

where e_p is the potential gravitational energy per volume, e_k is the kinetic energy per volume, and the surface tension σ is the potential energy per surface area. Under the assumption that energy is not created or destroyed in the domain we shall set up an integrated energy equation of the form

$$\frac{d}{dt} \left\{ \int_{\Omega} e_p dV + \int_{\Omega} e_k dV + \int_{WS} \sigma dS \right\} = - \int_{\Gamma} \mathbf{q}_{\Gamma} \cdot \hat{\mathbf{n}} ds - \int_{\Pi} \mathbf{q}_{\Pi} \cdot \hat{\mathbf{n}} dS \quad (2.34)$$

where \mathbf{q}_{Γ} is the surface energy flux density along the free surface WS , \mathbf{q}_{Π} is the energy flux density in the volume Ω and $\hat{\mathbf{n}}$ is the unit normal vector to the vertical side Π .

If we had included viscous effects a dissipative term would have appeared. A nonconservative volume force would also have given rise to a source term in the form of an integral over Ω .

We need a special case of Leibniz's rule

$$\frac{d}{dt} \int_{\Omega} G dV = \int_{\Omega} \frac{\partial G}{\partial t} dV + \int_{WS} G|_{z=\eta} \frac{\partial \eta}{\partial t} dA \quad (2.35)$$

where dA is an infinitesimal element in the horizontal xy -plane, and the last term is due to time variation of the free surface. One can note that this term alone gives the contribution to the change of e_p because the gravity potential is time independent.

We now set up the equations which control the motion and which we will deduce the energy equation (2.34) from. Some of these are given earlier, but we repeat them here for the sake of overview. First we have the equation of motion for an ideal fluid

$$\frac{\partial \mathbf{v}}{\partial t} = -\nabla \left(\frac{\mathbf{v}^2}{2} \right) - \frac{1}{\rho} \nabla p - \nabla \Phi \quad (2.36)$$

where we have assumed irrotationality to restate the convective term. Instead of introducing the acceleration of gravity explicitly, we use a general force potential Φ . The fluid is incompressible and the continuity equation is then

$$\nabla \cdot \mathbf{v} = 0. \quad (2.37)$$

At the free surface we have the dynamic condition

$$p = \sigma \nabla \cdot \mathbf{n} \quad (2.38)$$

where \mathbf{n} is the unit normal vector to the free surface WS . In addition, we have the kinematic surface condition (2.5) which can be written in the form of

$$\mathbf{v} \cdot \mathbf{n} \, dS = \frac{\partial \eta}{\partial t} \, dA \quad (2.39)$$

where dA is the projection of dS down in the xy -plane.

Now following some manipulation we obtain the energy equation in the desired form. We start by taking the dot product of (2.36) with the velocity vector and integrate the result over Ω . Then we use Gauss' theorem to arrive at the equation

$$\int_{\Omega} \frac{\partial}{\partial t} \left(\frac{1}{2} \rho \mathbf{v}^2 \right) dV = - \int_{\partial\Omega} \left(p + \frac{1}{2} \rho \mathbf{v}^2 + \rho \Phi \right) \mathbf{v} \cdot \mathbf{n} \, dS \quad (2.40)$$

where $\partial\Omega$ designates the edge of Ω , i.e. the union of the free surface WS , the vertical side Π and the bottom. There is however no contribution from the bottom due to the kinematic bottom condition (2.13). The unit normal vector \mathbf{n} points outwards. We now use (2.35) to write the equation in a form which provides the time derivative of the integrated kinetic and potential energy in a gravity field. The kinematic surface condition (2.39) gives us that most of the terms in the surface integral cancel and we end up with

$$\frac{d}{dt} \left\{ \int_{\Omega} e_p \, dV + \int_{\Omega} e_k \, dV \right\} = - \int_{WS} p \mathbf{v} \cdot \mathbf{n} \, dS - \int_{\Pi} \left(p + \frac{\rho}{2} \mathbf{v}^2 + \rho \Phi \right) \mathbf{v} \cdot \hat{\mathbf{n}} \, dV \quad (2.41)$$

Now using (2.38) and (2.39) the first term in the right side in (2.41) we write

$$- \int_{WS} p \mathbf{v} \cdot \mathbf{n} \, dS = - \int_{WS} \sigma \nabla \cdot \mathbf{n} \frac{\partial \eta}{\partial t} \, dA. \quad (2.42)$$

By further using $\mathbf{n} = (\mathbf{k} - \nabla \eta) / \sqrt{1 + (\nabla \eta)^2}$ we have the identity

$$\nabla \cdot (\mathbf{n} \eta_t) = \nabla \cdot \mathbf{n} \eta_t + \mathbf{n} \cdot \nabla \eta_t = \nabla \cdot \mathbf{n} \eta_t - \frac{\nabla \eta \cdot \nabla \eta_t}{\sqrt{1 + (\nabla \eta)^2}}$$

and therefore we have, with use of both Leibnitz' rule and Gauss' theorem,

$$- \int_{WS} \sigma \nabla \cdot \mathbf{n} \frac{\partial \eta}{\partial t} \, dA = - \frac{d}{dt} \int_{WS} \sigma \, dS - \int_{\Gamma} \sigma \mathbf{n} \cdot \hat{\mathbf{n}} \frac{\partial \eta}{\partial t} \, ds \quad (2.43)$$

where $\hat{\mathbf{n}}$ is the unit normal vector to Π and \mathbf{n} is the unit normal vector to the free surface S , and ds is an infinitesimal curve element along the projection of Γ into the xy -plane. The first term on the right side is the change in total surface

energy, while the second term is the total energy flux of the surface energy (both advection of surface energy through Γ and the surface tension acting on the curve Γ).

Let us sum up everything

$$\begin{aligned} & \frac{d}{dt} \left\{ \int_{\Omega} \frac{\rho}{2} \mathbf{v}^2 dV + \int_{\Omega} \rho \Phi dV + \int_{WS} \sigma dS \right\} \\ &= - \int_{\Gamma} \sigma \hat{\mathbf{n}} \cdot \mathbf{n} \frac{\partial \eta}{\partial t} ds - \int_{\Pi} \left(p + \frac{\rho}{2} \mathbf{v}^2 + \rho \Phi \right) \mathbf{v} \cdot \hat{\mathbf{n}} dS \end{aligned} \quad (2.44)$$

where the contributions on the left side are the change in kinetic energy, the change in potential gravitational energy, and the change in surface energy. The contributions on the right side are the flux of surface energy through the curve Γ , the action of pressure on the vertical wall Π , transport of kinetic energy through Π and transport of potential gravity energy through Π . With the help of Euler's pressure formula, the three terms in the brackets can be simplified

$$\frac{d}{dt} \left\{ \int_{\Omega} \frac{\rho}{2} \mathbf{v}^2 dV + \int_{\Omega} \rho \Phi dV + \int_{WS} \sigma dS \right\} = - \int_{\Gamma} \sigma \hat{\mathbf{n}} \cdot \mathbf{n} \frac{\partial \eta}{\partial t} ds + \int_{\Pi} \rho \frac{\partial \phi}{\partial t} \mathbf{v} \cdot \hat{\mathbf{n}} dS \quad (2.45)$$

A simple illustration of the right side in (2.45) for the two-dimensional geometry is given in figure 2.7. For two-dimensional geometry $\hat{\mathbf{n}} \cdot \mathbf{n} = \sin \alpha$ where α is the slanting angle to the surface that is defined in the figure. Work per unit of time which the fluid to the left of the section A–A performs on the fluid to the right is

$$W = -\sigma \frac{\partial \eta}{\partial t} \sin \alpha - \int_{-h}^{\eta} \rho \frac{\partial \phi}{\partial t} u dz.$$

We shall now consider the energy flux density integrated in the vertical direction, \mathbf{F} , defined such that the right side of the equation (2.45) can be written in the form

$$- \int_{\Gamma} \hat{\mathbf{n}} \cdot \mathbf{F} ds$$

where the infinitesimal curve element ds is along the projection of Γ into the xy -plane. Taylor expansion of the horizontal energy flux density for small values of the derivative of η and ϕ now gives

$$\hat{\mathbf{n}} \cdot \mathbf{F} = \hat{\mathbf{n}} \cdot \left[\sigma \nabla \eta \frac{\partial \eta}{\partial t} + \int_{-h}^0 \rho \frac{\partial \phi}{\partial t} \nabla \phi dz \right].$$

In agreement with previous assumptions, only those terms for which the wave amplitude occurs to quadratic order have been included. Introducing the velocity potential and surface displacement (2.14), we therefore find, with the help of the

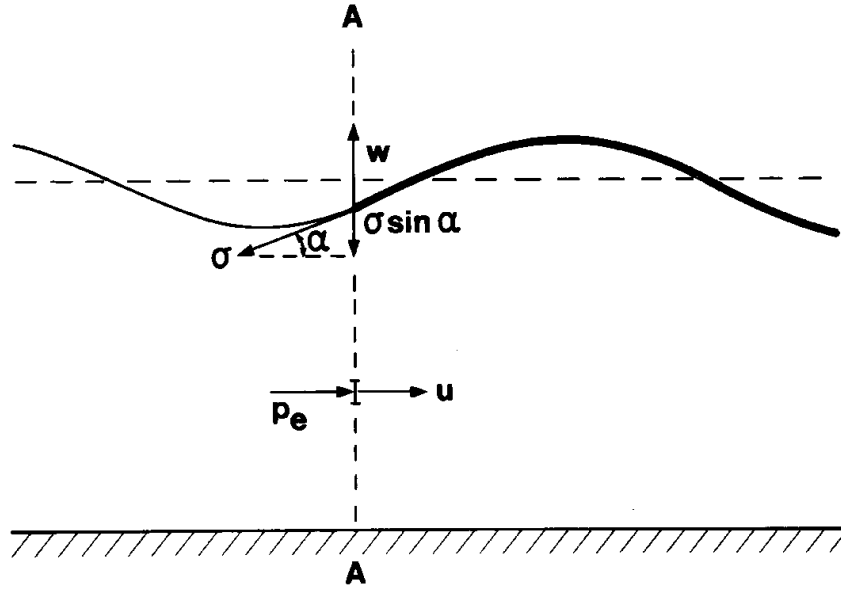

Figure 2.7: Illustration of energy flux.

relations (2.15)–(2.16) and with the time averaging (2.23) that the average energy flux density \mathbf{F} (power per length along the wave) is

$$\mathbf{F} = E\mathbf{c}_g \quad (2.46)$$

where the magnitude

$$\mathbf{c}_g = \frac{c}{2} \left[\frac{1 + \frac{3\sigma k^2}{\rho g}}{1 + \frac{\sigma k^2}{\rho g}} + \frac{2kH}{\sinh 2kH} \right] \frac{\mathbf{k}}{k} \quad (2.47)$$

is a vector in the same direction as the wave vector \mathbf{k} , and which has the same dimensions as velocity, and E is the energy density for gravity–capillary waves. By differentiation of (2.15) we find that the group velocity is

$$\mathbf{c}_g = \frac{\partial \omega}{\partial \mathbf{k}}.$$

The vector \mathbf{c}_g defines the *group velocity* and we shall discuss this quantity in the next section. So far we have noticed that the energy flux density is equal to energy density multiplied by the group velocity. This is valid for linear wave motion.

For gravity waves in deep water ($kH \gg 1$) the energy flux density (power per length along the wave crest) is

$$F = \frac{1}{4} \rho g a^2 c. \quad (2.48)$$

The table below shows the phase speed, period, and energy flux density for gravity waves with wavelengths from 1–150 m and amplitude 0.1 m. The water depth is assumed to be much larger than the wavelength such that we can employ the theory of infinitely deep water.

$\lambda(\text{m})$	$c(\text{m/s})$	$T(\text{s})$	$F(\text{W/m})$
5	2.79	1.79	69
10	3.95	2.53	97
25	6.25	4.00	153
50	8.84	5.66	217
75	10.82	6.93	265
100	12.50	8.00	307
150	15.30	9.80	375

Exercises

1. We look at a sea basin with depth 10 m and with a straight coastline. A buoy registers waves with period 7 s and amplitude 0.5 m. Assume that the coast absorbs all incoming wave energy. Estimate the importance of finite depth and/or surface tension. Compute the wavelength, phase speed, and group velocity. How much power is absorbed by a 500 m long coastline? How long a coastline would be sufficient to cover the energy needs for a household?
2. A tsunami has amplitude 2 m in 5000 m deep water. Determine the phase speed and group velocity (km/h), energy density (kWh/m²) and energy flux density (kW/m).

2.5 A simple kinematic interpretation of group velocity. Group velocity for surface waves.

In the previous section we have seen that the velocity $c_g = \frac{d\omega}{dk}$ is related to the energy flux in plane surface waves. In this section we shall give a simple kinematic interpretation of the magnitude c_g which also justifies the definition group velocity. We add up two wave components η_1 and η_2 with the same amplitude but with slightly different values for wave number and angular frequency.

$$\eta_1 = \frac{1}{2}a \sin[(k + \Delta k)x - (\omega + \Delta\omega)t]$$

and

$$\eta_2 = \frac{1}{2}a \sin[(k - \Delta k)x - (\omega - \Delta\omega)t]$$

where $2\Delta k$ and $2\Delta\omega$ are respectively different in wave number and angular frequency. With the help of the formula for the summation of two sine functions, we find

$$\eta = \eta_1 + \eta_2 = a \cos(\Delta kx - \Delta\omega t) \sin(kx - \omega t). \quad (2.49)$$

The equation (2.49) depicts a series of wave groups or wave packets where the amplitude of the individual waves within a group varies from 0 to a . Wavelength for the wave group is $\lambda_g = 2\pi/\Delta k$, and the wavelength for the individual waves in the group is $\lambda = 2\pi/k$. The individual crests propagate with phase speed $c = \omega/k$, but the wave group propagates with group velocity

$$c_g = \frac{\Delta\omega}{\Delta k} = \frac{d\omega}{dk}. \quad (2.50)$$

For wave motion in more spatial dimensions we find that the group velocity is a vector defined such that the gradient of the angular frequency ω with respect to the wave number vector \mathbf{k} , $\mathbf{c}_g = \partial\omega/\partial\mathbf{k}$. For isotropic waves, i.e., when the dispersion relation only depends on wave number and not the direction of the wave number vector, we see that the group velocity vector has the same direction as the wave number vector. With the help of the relation $\omega = ck$ we can write

$$c_g = c + k \frac{dc}{dk} = c - \lambda \frac{dc}{d\lambda} \quad (2.51)$$

which shows that for dispersive waves, the group velocity is different from the phase speed. For nondispersive waves, the group velocity is equal to the phase speed. The group velocity is larger or smaller than the phase speed depending on if the phase speed depends on if the phase speed decreases or increases with wavelength. For gravity waves $c_g < c$, but $c_g > c$ for capillary waves. Since individual waves propagate with a velocity different from the wave group's velocity, an observer following an individual wave in the group will see the wave propagate through the group with a variable amplitude. The waves will therefore be lost from sight in the leading edge or trailing edge of the group depending on whether c is larger or smaller than c_g . Because the wave amplitude is zero at the leading edge and trailing edge of every wave group, this indicates that the energy within the wave group always spreads with the group velocity. We have already seen that this interpretation is correct for surface waves.

With the help of (2.51) it is possible to find c_g graphically by drawing the tangent to the graph $c = c(\lambda)$. This method is shown in figure 2.9. Group velocity for surface waves is given by (2.47). By these expressions we see that for surface waves in deep water, $kH \gg 1$, such that

$$c_g = \frac{1}{2} c \frac{1 + \frac{3\sigma k^2}{\rho g}}{1 + \frac{\sigma k^2}{\rho g}} \quad (2.52)$$

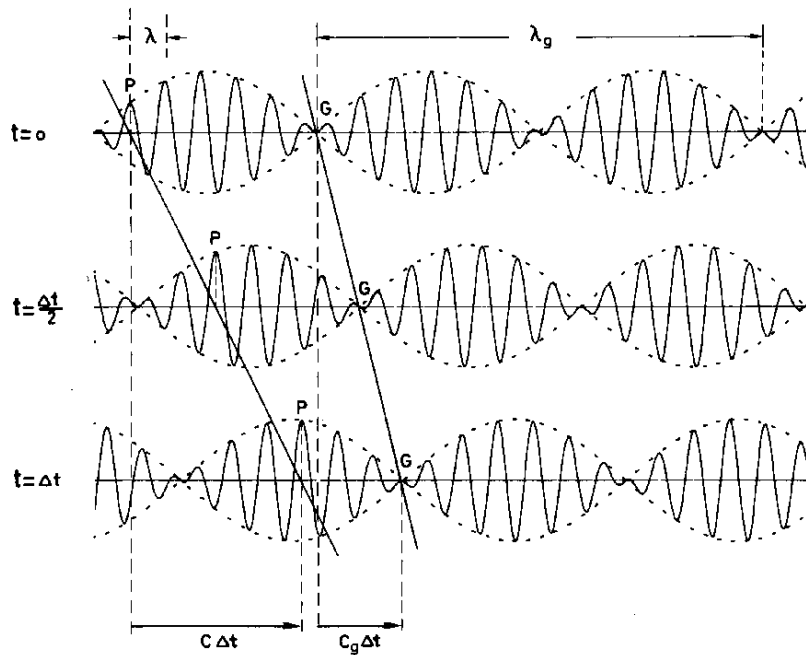

Figure 2.8: Graph of the function $\eta = a \cos(\Delta kx - \Delta \omega t) \sin(kx - \omega t)$ and with slope curve $a \cos(\Delta kx - \Delta \omega t)$ at three different times for a wave train with $c_g = c/2$. Forward movement of the wave group (G) and an individual wave (P) are marked.

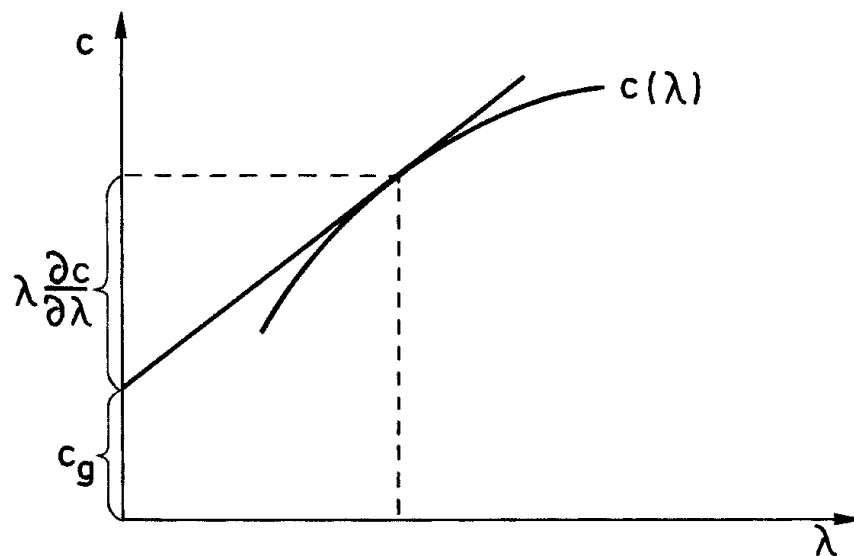

Figure 2.9: Phase speed and group velocity.

where the phase speed c is known by (2.18). Depending on if the wave length is much larger or much smaller than λ_m (see equation 2.17) we find

$$\begin{aligned} c_g &= \frac{1}{2}c & \text{when } \lambda &\gg \lambda_m \\ c_g &= \frac{3}{2}c & \text{when } \lambda &\ll \lambda_m \end{aligned} \quad (2.53)$$

These are expressions for group velocity for gravity and capillary waves respectively in deep water.

For surface waves in shallow water, $kH \ll 1$, we find from earlier methods

$$\begin{aligned} c_g &= c = c_0 & \text{when } \lambda &\gg \lambda_m \\ c_g &= 2c & \text{when } \lambda &\ll \lambda_m \end{aligned}$$

See figure 2.10 and 2.11.

In this section we have shown that a series of wave groups appear by the interference of two harmonic wave components. In the exercises with section 2.7 it will become evident that a single wave group or wave packet can be composed by a number of harmonic wave components.

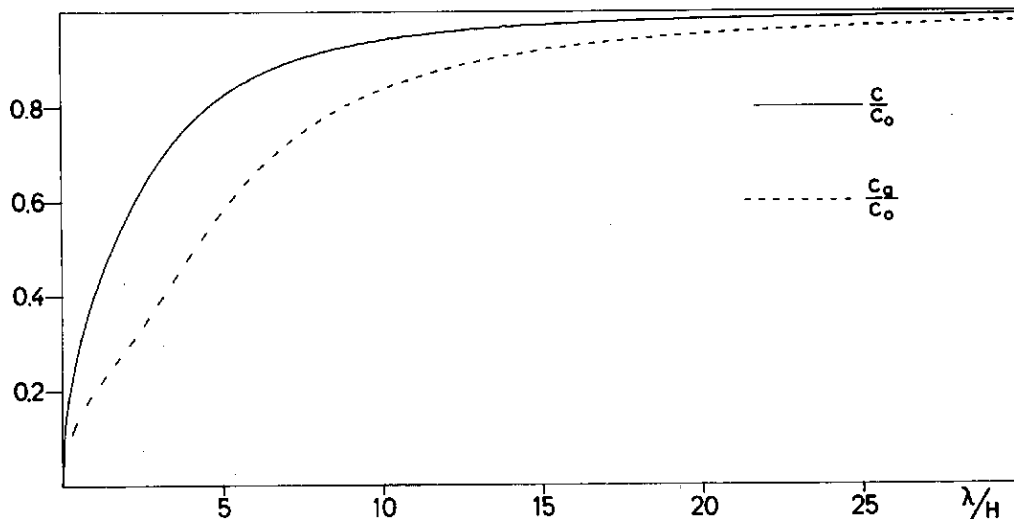

Figure 2.10: Phase speed and group velocity for gravity waves.

Wave groups often operate in nature, and a typical example of this is swells. Figure 2.12 shows wave groups registered in swells at Trænabanken. The seismograph in figure 3.1 in section 2.13 also shows wave groups.

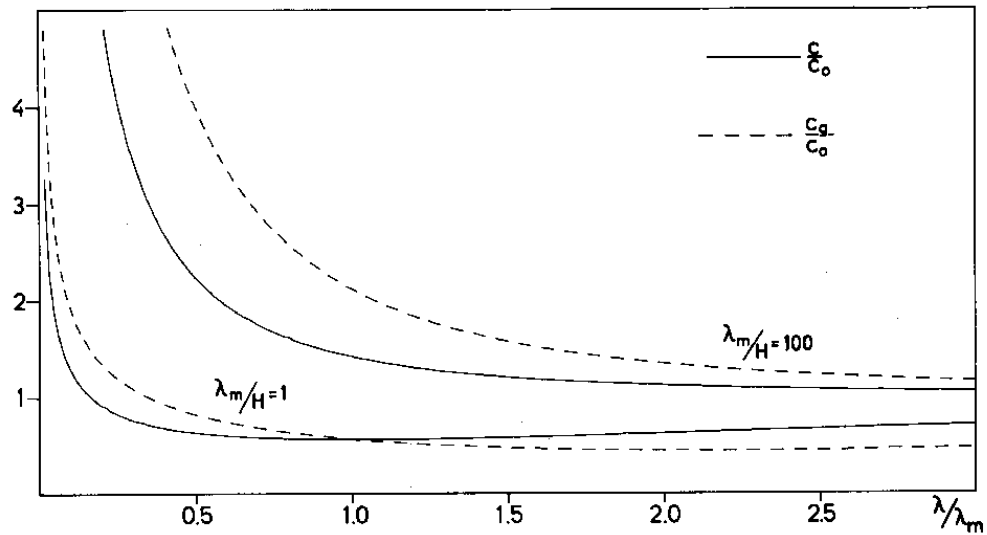

Figure 2.11: Phase speed and group velocity for gravity and capillary waves.

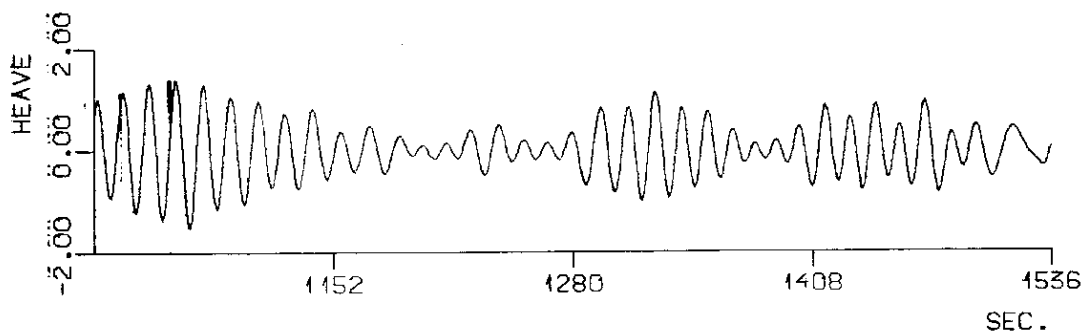

Figure 2.12: Long periodic rising and sinking of the water surface (in meters) registered on 24 January 1982 at 9 GMT by a buoy anchored at Trænabanken off the coast of Helgeland. The swells came from a storm-center in the North-Atlantic east of New-Ffoundland (Gjevik, Lygre and Krogstad, 1984).

2.6 The Klein-Gordon equation

As an example to illustrate the two previous sections we shall consider the Klein-Gordon equation

$$\frac{\partial^2 \eta}{\partial t^2} - c_0^2 \frac{\partial^2 \eta}{\partial x^2} + c_0^2 q^2 \eta = 0 \quad (2.54)$$

where c_0 and q are constant and η is a functions of x and t .

This equation describes, for example, the motion of an oscillating string where in addition to tension in the string, spring forces pull the string in towards the equilibrium position. The Klein-Gordon equation furthermore describes phenomena within relativistic quantum mechanics, and it occurs also for long gravity-inertia waves in rotating fluids.

The equation allows for waves of the form

$$\eta = a \sin k(x - ct)$$

where the phase speed is

$$c = c_0(1 + q^2/k^2)^{\frac{1}{2}}$$

The group velocity is

$$c_g = \frac{d(ck)}{dk} = \frac{c_0^2}{c}$$

The energy equation comes out by multiplying the Klein-Gordon equation by $\frac{\partial \eta}{\partial t}$, and we find after reordering

$$\frac{\partial E}{\partial t} + \frac{\partial F}{\partial x} = 0$$

where the energy density (per mass unit) is

$$E = \frac{1}{2} \left[\left(\frac{\partial \eta}{\partial t} \right)^2 + c_0^2 \left(\frac{\partial \eta}{\partial x} \right)^2 + c_0^2 q^2 \eta^2 \right]$$

and the energy flux is

$$F = -c_0^2 \frac{\partial \eta}{\partial x} \frac{\partial \eta}{\partial t}$$

With use of the wave solution we can estimate the average energy density and energy flux, and we find

$$\begin{aligned} \bar{E} &= \frac{1}{2} a^2 k^2 c^2 \\ \bar{F} &= \frac{1}{2} a^2 k^2 c_0^2 c \end{aligned}$$

The average propagation velocity for the energy is therefore

$$\frac{\bar{F}}{\bar{E}} = \frac{c_0^2}{c} = c_g$$

2.7 Surface waves generated by a local disturbance in the fluid

When a stone is cast into still and relatively deep water, a train of regular waves which propagate radially out from the point where the stone hit the surface is formed. If the stone is comparatively large, we will see long waves in the front of the wave train and gradually shorter waves in towards the center of the motion. The cause of this is that the mechanical energy which is contributed to the water by the stone will distribute itself into different wave components, which propagate out with a velocity which is dependent on wavelength. After a time, the long waves will have outran the shorter, and the original disturbance is canceled out into a regular wave train with gradually varying wavelengths. If the stone is tossed into shallow water, then all of the wave components with wavelength greater than the water's depth will move with nearly the same velocity. In this case the disturbance can extend over a long distance without noticeably altering form. If an adequately small stone is released into the water, the long waves generated will have a very small amplitude such that only the wave components with wavelength $\lambda \leq \lambda_m$ are visible. In this case, a wave train will develop with shorter waves in front and longer waves in back.

We shall now handle some of the mathematical phenomena. For simplicity's sake, we shall limit ourselves to two-dimensional wave motion which can be thought of as arising from an elongated disturbance. This case is mathematically easier to treat than the case where the waves propagate in all directions and the wave amplitude decreases because the energy associated constantly spreads out over a large area. Here we shall also handle the case where the motion starts from rest with an elevation or sinking of the surface. The initial conditions can therefore be written

$$\begin{aligned}\phi &= 0 & \text{for} & & t = 0 \\ \eta &= \eta_0(x) & \text{for} & & t = 0\end{aligned}\tag{2.55}$$

To solve the equations (2.11) with the boundary conditions (2.12)–(2.13) and the initial conditions (2.55) we introduce the Fourier transform with respect to that x which we define as

$$\tilde{f}(k) = \int_{-\infty}^{+\infty} f(x)e^{-ikx} dx\tag{2.56}$$

where $f(x)$ is a function of x such that the integral (2.56) exists. The corresponding inverse transform is

$$f(x) = \frac{1}{2\pi} \int_{-\infty}^{+\infty} \tilde{f}(k)e^{ikx} dk\tag{2.57}$$

We assume that both ϕ and the derivative η also goes to zero for $x \rightarrow \pm\infty$ and the Fourier transform of these functions exists. By integration by parts we find

that

$$\frac{\partial^n \widetilde{\phi}}{\partial x^n} = (ik)^n \widetilde{\phi} \quad \text{for} \quad (n = 1, 2, \dots)$$

From this follows that the Fourier transform of the Laplace equation (2.11) can be written

$$\frac{\partial^2 \widetilde{\phi}}{\partial z^2} - k^2 \widetilde{\phi} = 0 \quad (2.58)$$

The transform of the first of the two boundary conditions (2.12) gives

$$\widetilde{\eta} = -\frac{1}{g(1 + \frac{\sigma k^2}{\rho g})} \left(\frac{\partial \widetilde{\phi}}{\partial t} \right)_{z=0} \quad (2.59)$$

and by elimination of $\widetilde{\eta}$ with the help of the other conditions in (2.12) we find

$$\frac{\partial^2 \widetilde{\phi}}{\partial t^2} + g \left(1 + \frac{\sigma k^2}{\rho g} \right) \frac{\partial \widetilde{\phi}}{\partial z} = 0 \quad \text{for} \quad z = 0 \quad (2.60)$$

The transform of the boundary conditions (2.13) is

$$\frac{\partial \widetilde{\phi}}{\partial z} = 0 \quad \text{for} \quad z = -H \quad (2.61)$$

Finally the Fourier transform of the initial conditions (2.55)

$$\widetilde{\phi} = 0 \quad \text{og} \quad \widetilde{\eta} = \widetilde{\eta}_0 \quad \text{for} \quad t = 0 \quad (2.62)$$

A solution of (2.58) that satisfies the boundary conditions (2.61) can be written

$$\widetilde{\phi} = A(t) \cosh k(z + H) \quad (2.63)$$

where $A(t)$ is an undefined function of t .

Setting in (2.60) gives

$$\frac{d^2 A}{dt^2} = -\omega^2 A$$

where ω is given by the dispersion relation (2.15). The initial conditions (2.62) result in that $A = 0$ for $t = 0$, and the solution for the last equation can therefore be written

$$A(t) = A_0 \sin \omega t \quad (2.64)$$

where the constant A_0 is determined with the help of (2.59), (2.63) and the initial conditions (2.62) for $\widetilde{\eta}$. We find that

$$A_0 = -\frac{g(1 + \frac{\sigma k^2}{\rho g})}{\omega \cosh kH} \widetilde{\eta}_0 \quad (2.65)$$

The inverse of the transformed expression (2.63) with $A(t)$ given by (2.64) and (2.65) gives the velocity potential

$$\phi = -\frac{g}{2\pi} \int_{-\infty}^{+\infty} \frac{\sin \omega t \cosh k(z+H)}{\omega \cosh kH} \left(1 + \frac{\sigma k^2}{\rho g}\right) \tilde{\eta}_0 e^{ikx} dk \quad (2.66)$$

Setting the velocity potential (2.66) into the other condition in (2.12) we find after integration that the surface displacement can be written

$$\eta = \frac{1}{4\pi} \left(\int_{-\infty}^{+\infty} \tilde{\eta}_0 e^{i(kx+\omega t)} dk + \int_{-\infty}^{+\infty} \tilde{\eta}_0 e^{i(kx-\omega t)} dk \right) \quad (2.67)$$

To arrive at (2.67) we also have to use the dispersion relation (2.15). Since $\tilde{\eta}_0(-k)$ is the complex conjugate of $\tilde{\eta}_0(k)$ and $\omega(-k) = \omega(k)$ the integrals can be converted such that one only integrates over positive values of k . Thereby we find

$$\eta = \frac{1}{2\pi} \int_0^{\infty} |\tilde{\eta}_0(k)| (\cos(kx - \omega t + \gamma) + \cos(kx + \omega t + \gamma)) dk$$

where γ is the argument of $\tilde{\eta}_0(k)$. This expression shows that the motion can be seen as consisting of a spectrum of harmonic wave components. We see that the original disturbance splits up into wave components which move in the positive or negative x -directions. The complex Fourier transform $\tilde{\eta}_0(k)$ determines the amplitude and phase distribution for the various wave components. The modulus squared $|\tilde{\eta}_0(k)|^2$ is proportional to the so-called *wave spectrum*, which in this case is the wave number spectrum.

If the spectrum is such that only the wave components where $\lambda \gg H$ are substantial, we can, according to (2.19) with good approximation, set $\omega = c_0|k|$ and integrate over the long periodic portion of the spectrum. Fourier integral can in (2.67) can be inverted and we find

$$\eta = \frac{1}{2} \eta_0(x + c_0 t) + \frac{1}{2} \eta_0(x - c_0 t)$$

This shows that the original disturbance will split into two identical pulses which move with constant velocity and without changing form in the positive and negative x -directions respectively. The amplitude for each of the pulses is half of the amplitude for the original disturbance (see figure 2.13).

To be able to discuss the wave motion given by (2.67) in detail we shall use a value of the function $\eta_0(x)$ which leads to a relatively simple integral by setting in (2.66) or (2.67). We set

$$\eta_0(x) = \frac{Q}{2L\sqrt{\pi}} e^{-(x/2L)^2} \quad (2.68)$$

where Q and L are constants. The functions are sketched for different values of L in figure 2.14. For the function (2.68) we have that

$$\int_{-\infty}^{+\infty} \eta_0(x) dx = Q$$

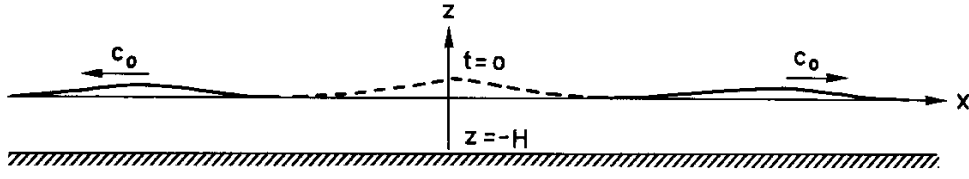

Figure 2.13: Wave motion excited from the original disturbance.

and

$$\tilde{\eta}_0(x) = Qe^{-(kL)^2} \tag{2.69}$$

The modulus $|\tilde{\eta}_0|$ is also symmetric around $k = 0$, and since $\tilde{\eta}_0$ is real, the phase is the same for all values of the wave components.

If $L \rightarrow 0$, then $\tilde{\eta}_0(x)$ degenerates to $Q\delta(x)$ where $\delta(x)$ is a delta-function with the properties

$$\int_{-\infty}^{+\infty} \delta(x) dx = 1 \quad \delta(x) = 0 \quad \text{for } x \neq 0$$

and

$$\tilde{\delta}(k) = 1$$

The delta-function also has a spectrum which gives equal amplitude for all the wave components (white spectrum).

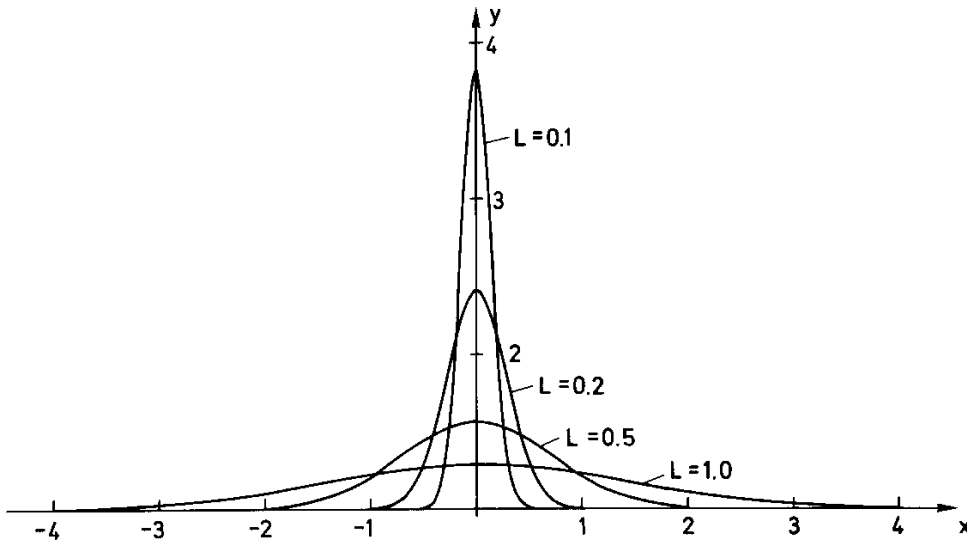

Figure 2.14: Gaussian start profile

For finite L (2.69) shows that the wave components in the spectrum with a wave number larger than $2\pi/L$ have vanishingly small amplitudes. This entails

that the substantial contribution to the integral (2.67) comes from the portion of the spectrum where the wavelength is larger than L . We see, without further ado, that a disturbance of the form (2.68) will not generate capillary waves of any significance unless $L < \lambda_m$ where λ_m is defined earlier.

When $\tilde{\eta}_0$ is given by (2.69), surface displacement is symmetric around the origin, and the surface displacement can be written

$$\eta = \frac{Q}{2\pi} \int_0^\infty e^{-(kL)^2} [\cos(kx + \omega t) + \cos(kx - \omega t)] dk \quad (2.70)$$

There are difficulties in discussing the full content of (2.70), and we shall limit the discussion here to gravity waves in deep water. In this case $\omega^2 = gk$. We introduce u which is a new variable of integration and set it in the first and second terms in the integral (2.70) respectively

$$\omega = \left(\frac{g}{x}\right)^{\frac{1}{2}}(u \mp r)$$

$$k = \frac{1}{x}(u^2 \mp 2ur + r^2)$$

$$kx \pm \omega t = u^2 - r^2$$

hvor

$$r = \left(\frac{gt^2}{4x}\right)^{\frac{1}{2}}$$

This now gives $L \rightarrow 0$

$$\eta = \frac{2Q}{\pi} \frac{r}{x} \int_0^r \cos(u^2 - r^2) du \quad (2.71)$$

The derivation of (2.71) implies some difficult boundary transitions and a few will perhaps prefer to go the route of the potential. One considers the potential around $z = 0$ and undertakes further substitutions in this expression. After one has found the converted expression for the potential, the surface displacement can be found with the help of the boundary conditions. Details are given by Lamb (1932). The equation (2.71) is an exact expression for surface displacement when the motion starts from rest, and the surface displacement at $t = 0$ has the form of a delta-function at the origin. This shows that surface displacement can be expressed by the Fresnel integrals

$$C(r) = \sqrt{\frac{2}{\pi}} \int_0^r \cos u^2 du$$

and

$$S(r) = \sqrt{\frac{2}{\pi}} \int_0^r \sin u^2 du$$

which are tabulated. Since (2.71) leads to large values for η near the origin, it is clear that the solution in this case clashes with the stipulation for linear wave theory. Far from the origin will, nevertheless, (2.71) give values of η which fulfill the requirements and which describe wave motion with a good approximation. With finite values for L , one will, on the other hand, find that the solution (2.70) gives reasonable values of η near the origin.

The surface displacement, equation (2.71), which is a function of t at a point at the distance $x = x_0$ from the origin is shown in figure 2.15. It is evident from

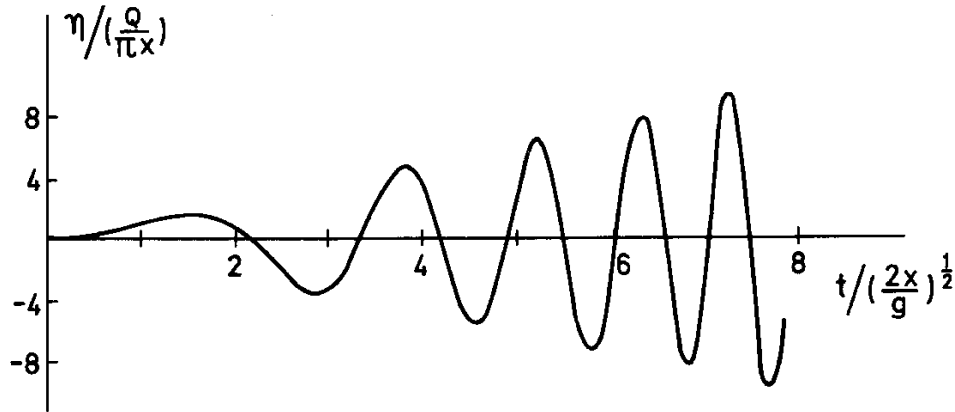

Figure 2.15: Surface displacement at a point.

the figure that the motion at every position starts with long periodic oscillations followed by oscillations with gradually shorter periods. We notice that the motion always starts at $t = 0$ even at points that are far away from the origin. This is related to the fact that in deep water, the longest gravity waves are spread with an infinitely large velocity, and the disturbance will be detected immediately in all points in the fluid. For $r \rightarrow \infty$

$$C(r) = S(r) = \frac{1}{2}$$

and it follows from (2.71) that the surface displacement can be written

$$\eta = \frac{Q}{2\sqrt{\pi}} \frac{g^{1/2} t}{x^{3/2}} \cos\left(\frac{gt^2}{4x} - \frac{\pi}{4}\right) \quad (2.72)$$

The graph for the function (2.72) at an indeterminate point in time $t = t_0$ is sketched in figure 2.16.

Let us now study the surface from a point in time t_0 , and again at point $x = x_0$. Taylor expansion of the phase function gives

$$\frac{gt_0^2}{4x} = \frac{gt_0^2}{4x_0} - \frac{gt_0^2}{4x_0} \left(\frac{x - x_0}{x_0}\right) + \dots$$

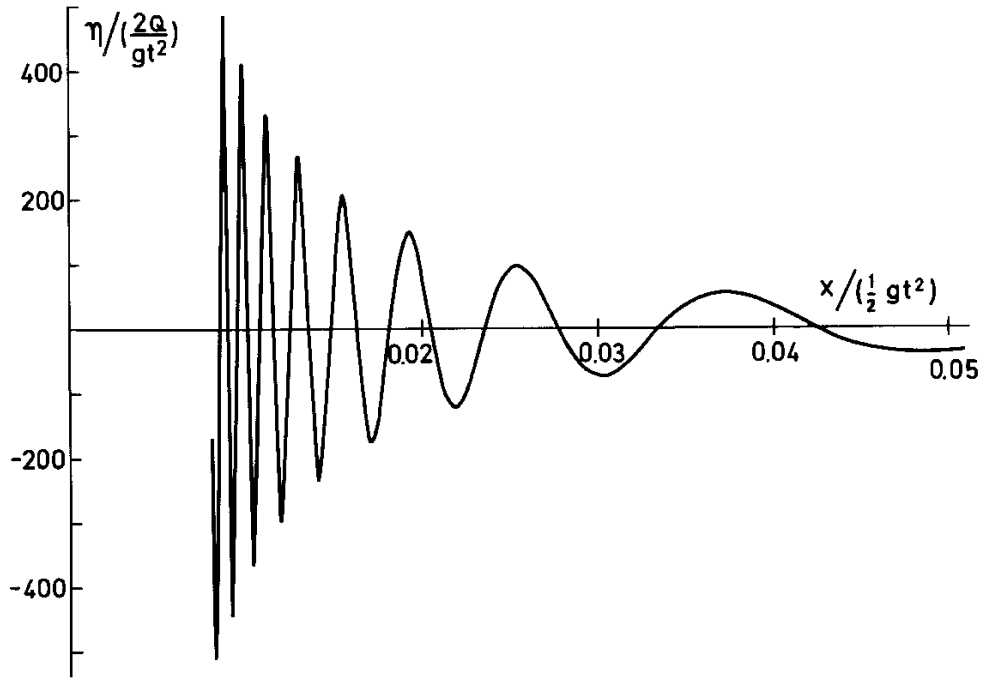

Figure 2.16: Surface displacement at an indeterminate point in time.

The wavelength λ corresponds to the change in the phase function of 2π

$$\lambda = |x - x_0| = \frac{8\pi x_0^2}{gt_0^2} \quad (2.73)$$

In the vicinity of the point $x = x_0$ the surface displacement will therefore be approximately periodic with the wavelength given above.

A fixed phase of the wave train, which may be a the zero-point $\eta = 0$, will be characterized by a fixed value for the phase function. This entails that the null points I_1, I_2 , and I_3 in figure 2.17 propagate in the x -direction such that

$$\frac{gt^2}{4x} = \text{constant}$$

This means that the points propagate with velocity

$$\dot{x} = \frac{2x}{t}$$

At a definite point in time, the velocity for I_1 is larger then for I_2 , and the velocity for I_2 is again larger then for I_3 . The waves are as such continuously extending in length.

Exercises

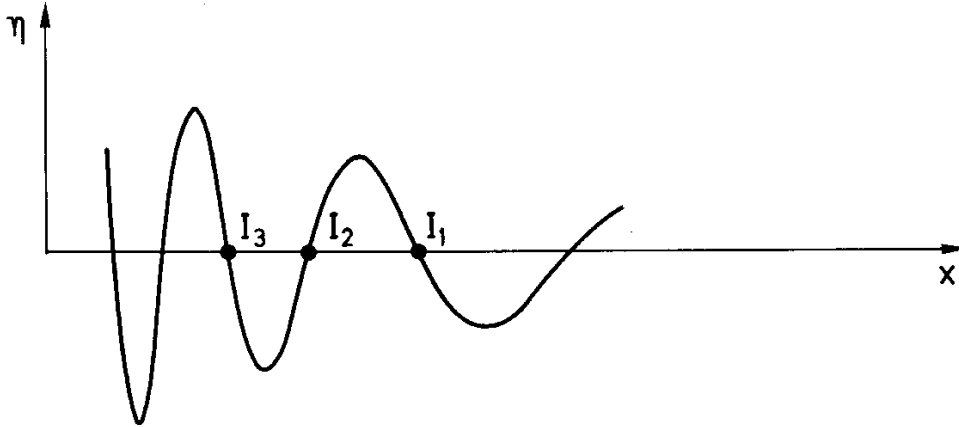

Figure 2.17: Sketch of the surface displacement.

1. The narrow band spectrum.

We write the surface displacement, which is the sum of an infinite number of harmonic wave components.

$$\eta(x, t) = \text{Re} \int_{-\infty}^{+\infty} a(k) e^{i(kx - \omega t)} dk$$

with

$$a(k) = \frac{a_0}{\kappa\sqrt{\pi}} e^{-(\frac{k-k_0}{\kappa})^2}$$

where a_0 , κ and k_0 are constants. Note that the wave number spectrum is proportional to $|a(k)|^2$. Show that at $t = 0$ the surface has the form of a Gaussian wave packet given by

$$\eta(x, t = 0) = a_0 e^{-\frac{\kappa^2 x^2}{4}} \cos k_0 x$$

We assume that the wave number spectrum is small band (κ is small) such that in the neighborhood of $k = k_0$, where we find the contributions to the integral, we can set

$$\omega(k) \simeq \omega(k_0) + \left(\frac{d\omega}{dk}\right)_{k_0} (k - k_0)$$

Show that

$$\eta(x, t) = a_0 e^{-\frac{\kappa^2(x - c_g t)^2}{4}} \cos(k_0 x - \omega(k_0)t)$$

where $c_g = \left(\frac{d\omega}{dk}\right)_{k_0}$. Sketch the surface displacement for different values of the parameters. Explain why the next term in the series expansion for ω will lead to the wave packet changing form by stretching out.

Hint: In an integral of the form $\int_{-\infty}^{+\infty} e^{-au^2 + bu} du$ substitute $u = v + b/2a$. The integral $\int_{-\infty}^{+\infty} e^{-av^2} dv = \sqrt{\frac{\pi}{a}}$.

2. Find the expression for the velocity potential ϕ and surface displacement η in the case that the fluid at $t = 0$ contributes an impulse such that $\phi(x, z = 0, t = 0) = \phi_0(x)$ while the surface $\eta(x, t = 0) = 0$.

2.8 Stationary phase approximation. Asymptotic expressions of the Fourier integral.

In the previous section we have shown that if the disturbance in the fluid is local, the velocity potential and surface displacement of the ensuing motion can be expressed with a Fourier integral of the type

$$\int_{-\infty}^{+\infty} F(k) e^{i(kx \pm \omega(k)t)} dk$$

where $F(k)$ is a function of k . It is, as we have seen, difficult to discuss the integral in general, and we shall find an asymptotic expression for the Fourier integral valid for large values of t and x . This derivation was originally done by Kelvin (1887). We shall treat the case where $t \rightarrow \infty$ but x/t has a fixed value. We let the interval of integration be arbitrary and write the integral in the form

$$I(x, t) = \int_a^b F(k) e^{it\chi(k)} dk \quad (2.74)$$

where a and b are constants and

$$\chi(k) = \frac{x}{t}k \pm \omega(k)$$

For large values of t , the principal contributions to the integral (2.74) will come from values of k in the region around the value k_0 where $k = k_0$ denotes the point where the derivative of χ with respect to k is zero. Also

$$\chi'(k_0) = \omega'(k_0) \pm \frac{x}{t} = 0$$

For other values of k the integrand will oscillate rapidly. If $F(k)$ is a comparatively slowly varying function of k , the positive and negative contributions will abolish each other. The net contribution to the integral for these values of k will therefore be negligible.

We now develop the functions $F(k)$ and $\chi(k)$ in Taylor series in the neighborhood of the point $k = k_0$. This gives

$$\begin{aligned} F(k) &\simeq F(k_0) \\ \chi(k) &\simeq \chi(k_0) + \frac{1}{2}\chi''(k_0)(k - k_0)^2 \end{aligned}$$

under the requirement that $\chi''(k_0) \neq 0$. This series expansion is set into (2.74) and we find

$$I(x, t) \simeq F(k_0)e^{it\chi(k_0)} \int_a^b e^{\frac{i}{2}t\chi''(k_0)(k-k_0)^2} dk.$$

Since the integrand in this integral oscillates rapidly for large values of $k - k_0$, we can without mentionable error expand the limit of the integral to $\pm\infty$. From known formulas we have that the integral

$$\int_{-\infty}^{+\infty} e^{\pm im^2 u^2} du = \frac{\sqrt{\pi}}{m} e^{\pm i\frac{\pi}{4}}$$

where m is a positive constant. Using this result gives

$$I(x, t) \simeq \frac{\sqrt{2\pi}F(k_0)}{\sqrt{t|\chi''(k_0)|}} e^{i(\chi(k_0)t \pm \frac{\pi}{4})} \quad (2.75)$$

where the upper or lower sign in the exponent is valid when $\chi''(k_0)$ is positive or negative. This is the stationary phase approximation for the Fourier integral. If $\chi'(k) = 0$ has several zero-points which lay sufficiently spread from each other, one will get a sum of the contributions where every single term is of the form (2.75).

If we include an additional term in the series expansion for χ ; this term will be

$$\frac{1}{6}\chi'''(k_0)(k - k_0)^3.$$

The formula (2.75) is therefore only valid when

$$|(k - k_0)\chi'''(k_0)/\chi''(k_0)| \ll 1$$

in the whole region for k which gives a contribution to the integral, that is when the integrand oscillates, see figure 2.18.

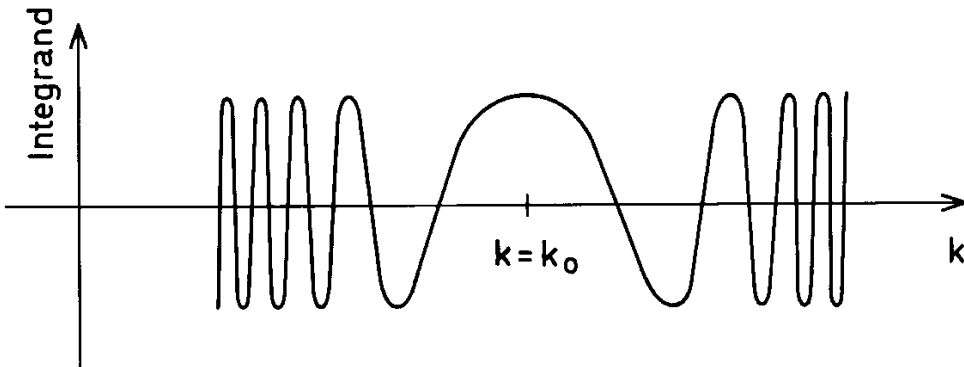

Figure 2.18: Sketch of the principle for stationary phase.

One therefore finds the contribution to the integrand for k -values where

$$t(k - k_0)^2 \chi''(k_0) \leq 2\pi n$$

where n is a small integer. These combined with the claim above give that

$$q = t^{-\frac{1}{2}} |\chi'''(k_0)| / |\chi''(k_0)|^{3/2} \ll 1$$

for that the approximation (2.75) shall be valid.

Let us now use the stationary phase approximation to find an asymptotic expression for the surface displacement for gravity waves in deep water generated by a surface displacement in the form of a delta function at the origin ($x = 0$). The motion of the surface for $x > 0$ due to waves which propagate in the x -direction, and the surface displacement for $x > 0$ can, according to the results in section 2.7 be written

$$\eta(x, t) = \frac{Q}{2\pi} \operatorname{Re} \int_0^\infty e^{i(kx - \omega t)} dk.$$

We set the following

$$\begin{aligned} F(k) &= \frac{Q}{2\pi}, \\ \chi(k) &= k \frac{x}{t} - g^{\frac{1}{2}} k^{\frac{1}{2}}. \end{aligned}$$

This gives

$$k_0 = \frac{gt^2}{4x^2}, \quad \chi'(k_0) = 0, \quad \chi(k_0) = -\frac{gt}{4x},$$

and

$$\chi''(k_0) = \frac{2x^3}{gt^3}, \quad \chi'''(k_0) = -12 \frac{x^5}{g^2 t^5}.$$

By using (2.75), we find an expression for surface displacement which is identical to the earlier expressions we found in (2.72). The magnitude q is proportional to $(2x/gt^2)^{\frac{1}{2}}$ which shows that the approach is valid given that $\frac{1}{2}gt^2 \gg x$. This is also in agreement with what we have found earlier.

Exercises

1. Use the stationary phase approximation to find the surface displacement for gravity waves in deep water when $L \neq 0$. Discuss the solution.
2. Use the stationary phase approximation to find the surface displacement for capillary waves in deep water. Let the initial disturbance have the form of a delta function. Compare with the solution for gravity waves.

3. We have given the Klein-Gordon equation in the form:

$$\frac{\partial^2 \eta}{\partial t^2} - c_0^2 \frac{\partial^2 \eta}{\partial x^2} + q\eta = 0$$

which is valid for $t > 0$ and $-\infty < x < \infty$. Waves are generated from the initial disturbance

$$\eta(x, 0) = A_0 e^{-\left(\frac{x}{t}\right)^2}, \quad \frac{\partial \eta(x, 0)}{\partial t} = 0.$$

Find an approximate solution for large x and t and discuss where this is valid.

2.9 Asymptotic generation of the wave front

If we assume infinite depth, we will not have any clear limitation of the wave train generated from an initial disturbance except that the amplitude will decrease gradually in connection with the distribution of energy in the spectrum. If we assume finite depth, we have a limitation in the velocity of gravity waves and we must expect that a clear definition for the wave train exists. This will be studied below.

The Fourier transform used for the initial value problem gives the inversion integral

$$\eta(x, t) = \frac{1}{2\pi} \operatorname{Re} \int_0^{\infty} \tilde{\eta}_0 e^{i\chi} dk; \quad \chi \equiv kx - \omega(k)t \quad (2.76)$$

for the portion of the wave train which propagates in the positive x -direction. For large values of x and t , the dominant contribution will come from the stationary point in the phase plane, k_s , where

$$\frac{d\chi(k_s)}{dk} = 0$$

which corresponds to

$$c_g(k_s) = \frac{x}{t}. \quad (2.77)$$

If we limit ourselves to gravity waves, the group velocity is confined by $c_0 = \sqrt{gH}$. We therefore find only the stationary points for $\frac{x}{t} \leq c_0$. For large values of x/t it is reasonable to assume that we have some waves — it has not had time to get there. For the condition $\frac{x}{t} = c_0$, we find a stationary point for $k_s = 0$. This is a second order stationary point in the sense that also $\chi''(k_s) = 0$. We take the third term in the Taylor series and we find

$$\chi \approx kx - c_0 \left(k - \frac{H^2}{6} k^3 \right) t \quad (2.78)$$

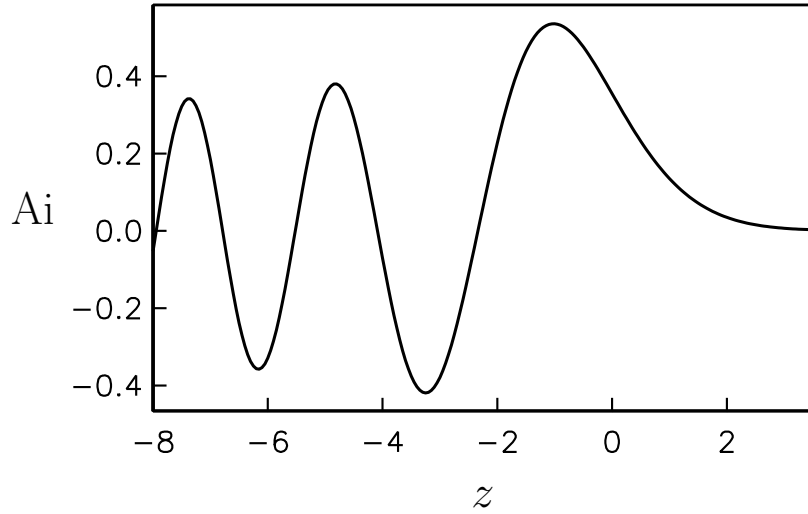

Figure 2.19: The Airy function.

and the integral

$$\eta(x, t) \approx \frac{1}{2\pi} \operatorname{Re} \int_0^{\infty} \tilde{\eta}_0(0) e^{i(kx - (c_0 k - \frac{H^2}{6} c_0 k^3)t)} dk. \quad (2.79)$$

A trivial substitution expression with the help of that integral

$$\operatorname{Ai}(z) = \frac{1}{\pi} \int_0^{\infty} \cos\left(\frac{1}{3}s^3 + zs\right) ds \quad (2.80)$$

which is an integral form of the Airy function Ai , which is a solution of Airy's equation

$$\frac{d^2 F}{dz^2} - zF = 0. \quad (2.81)$$

This plays a large roll in applied mathematics because the solutions ave an exponential variation for $z > 0$ and the trigonometric (oscillations) for $z < 0$. Therefore dips often show up in the local solution in the outer edge of the wave pattern. The Airy function is a solution of (2.81) which is exponentially decreasing when $z \rightarrow \infty$ and fulfills the normalization condition $\int_{-\infty}^{\infty} F dz = 1$. The Airy function is rendered in figure 2.19.

Near $x = c_0 t$ we find the asymptotic approximation

$$\eta \sim \frac{\frac{1}{2}\tilde{\eta}(0)}{(\frac{1}{2}c_0 H^2 t)^{\frac{1}{3}}} \operatorname{Ai}\left(\frac{x - c_0 t}{(\frac{1}{2}c_0 H^2 t)^{\frac{1}{3}}}\right) \quad (2.82)$$

where $\tilde{\eta}(0)$ is an integral of $\eta(x, 0)$.

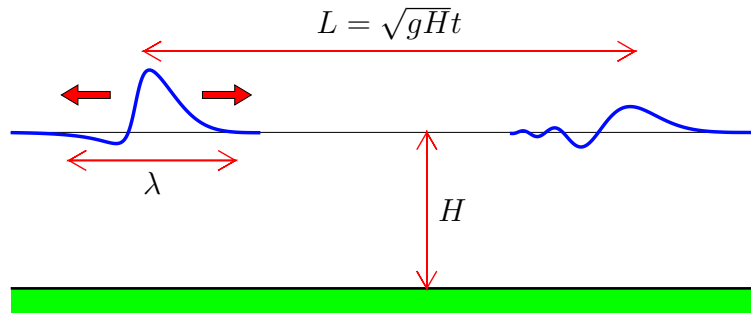

Figure 2.20: Definition sketch of initial conditions and wave spreading.

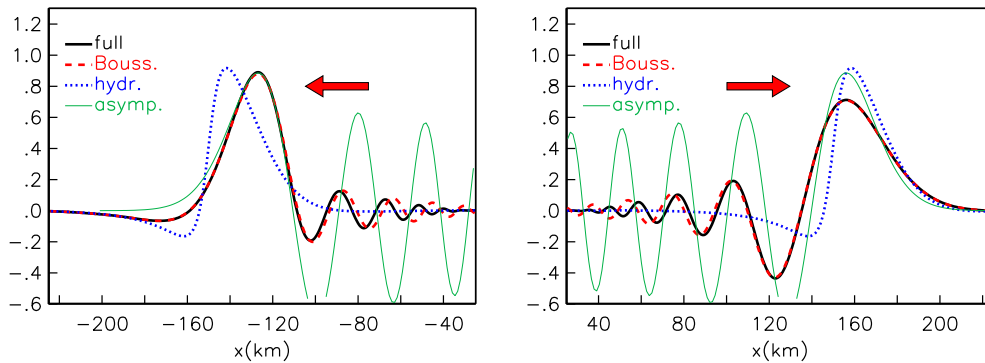

Figure 2.21: Spreading of earthquake generated surface waves (tsunami). Surface displacement (meter) is drawn after $t = 11.3$ minute which corresponds to a walkway $L = c_0 t = 150$ km when $H = 5$ km. The curve marked “full” is an exact numeric solution of the Laplace equation with boundary conditions, “Bouss.” is a solution of the Boussinesq equation, “hydr.” of the shallow water equation, while “asyp.” is the solution given by (2.82). We note that “hydr.” has results of the same form as the initial conditions, but has half the amplitude.

When $\frac{x - c_0 t}{(\frac{1}{2} c_0 H^2 t)^{\frac{1}{3}}} \rightarrow -\infty$ we can use the asymptotic expression for A_i . This can be used to match the asymptotic approximation with the normal stationary phase approximation for $x \rightarrow c_0 t^-$. We skip the details, but we see instead an example of this sort of spreading in tsunamis (figure 2.20). The extraneous mathematical solution is presented in figures 2.21 and 2.22. After theory of long waves has been worked through, it is a good idea to look closer at the relationship between the results.

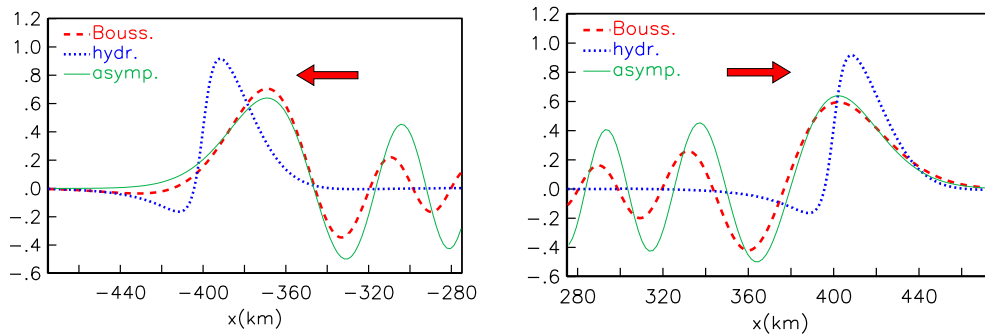

Figure 2.22: Surface displacement (m) after $t = 30$ minutes, $L = 400$ km. We note the differences between the numeric results and the asymptotic results are reduced in the second figure. 2.21.

2.10 Long waves in shallow water

If the wavelength is large comparison to the depth and the amplitude is sufficiently small, the water particles move in long funnels of elliptical paths and the horizontal velocity is much larger than the vertical velocity, then the waves are considered to be long waves in shallow water. The horizontal velocity is approximately constant as is the vertical shape, and the vertical acceleration in comparison with the acceleration due to gravity. The pressure in the fluid is therefore approximately hydrostatic and defined by the pressure of the overlaying fluid. These relationships can be exploited to derive the equation which describes the propagation of long waves in shallow water. These simplifications come from things such as the calculations of tides and maximum high tide, which is a wave phenomenon where the wavelength is much larger than half of the depth.

We introduce the horizontal volume flux

$$U = \int_{-H}^{\eta} u \, dz, \quad V = \int_{-H}^{\eta} v \, dz. \quad (2.83)$$

If the fluid is incompressible, then the net horizontal irruption in a fluid column must lead to an equivalent displacement of the surface. This can be written

$$\frac{\partial \eta}{\partial t} = -\frac{\partial U}{\partial x} - \frac{\partial V}{\partial y}. \quad (2.84)$$

This equation can also be obtained by integrating the continuity equation $\nabla \cdot \mathbf{v} = 0$ from $z = -H$ to $z = \eta$ and using the kinematic boundary conditions at the bottom and surface. We notice that linearization has not been done to arrive at equation (2.84). This is valid also in the case where the bottom is not a plane and H is a function of x and y .

Since the vertical acceleration is small given the linearized equation of motion in the vertical direction

$$\frac{\partial p}{\partial z} = -\rho g.$$

By integration we find the hydrostatic distribution of pressure which implies that the pressure in the fluid is known by the weight of the overlaying fluid. For a fluid with a uniform density

$$p = \rho g(\eta - z) + p_0$$

where p_0 designates the pressure over the fluid. By setting in the expression for p in the linearized equation of motion in the horizontal direction we find

$$\begin{aligned} \frac{\partial u}{\partial t} &= -g \frac{\partial \eta}{\partial x} \\ \frac{\partial v}{\partial t} &= -g \frac{\partial \eta}{\partial y} \end{aligned}$$

These equations show that if the approximation is valid, then u and v are independent of z . In this approximation is therefore

$$\begin{aligned} u &= U/H \\ v &= V/H \end{aligned}$$

This entails that the equation for horizontal motion can be written

$$\begin{aligned} \frac{\partial U}{\partial t} &= -c_0^2 \frac{\partial \eta}{\partial x} \\ \frac{\partial V}{\partial t} &= -c_0^2 \frac{\partial \eta}{\partial y} \end{aligned} \quad (2.85)$$

where $c_0^2 = gH$. The equations (2.84) and (2.85) are the linearized shallow water equations. The form that is written here is, on its own, very good for numerical integration. The derivation of equation (2.84) with respect to t and substituting the expressions for $\frac{\partial U}{\partial t}$ and $\frac{\partial V}{\partial t}$ from (2.85) leads to an equation for surface displacement

$$\frac{\partial^2 \eta}{\partial t^2} = \frac{\partial}{\partial x} \left(c_0^2 \frac{\partial \eta}{\partial x} \right) + \frac{\partial}{\partial y} \left(c_0^2 \frac{\partial \eta}{\partial y} \right). \quad (2.86)$$

If the bottom is a plane (c_0 independent of x and y), (2.86) reduces to the normal two-dimensional wave equation for non-dispersive waves. A wave solution of (2.84) and (2.85) can where c_0 is constant, be written

$$\begin{aligned} \eta &= a \sin k(x - c_0 t), \\ u &= \frac{a}{H} c_0 \sin k(x - c_0 t), \\ v &= 0. \end{aligned}$$

The equivalent vertical velocity is

$$w = -\frac{ka}{H}c_0(z + H) \cos k(x - c_0t).$$

One can easily introduce a correction term in the shallow water equation (2.85) which in some degree gets taken into consideration from the hydrostatic distribution of pressure. For simplicity's sake we shall see how this can be done in the case where the bottom is a plane and the motion takes place in a plane parallel with the xz -plane. This entails that the motion is independent of y and that $v = 0$. Under the requirement that the horizontal velocity is independent of z , we therefore find by integration of the continuity equation

$$w = -\frac{\partial u}{\partial x}(z + H).$$

From the linearized equation for vertical motion we find the following

$$\frac{\partial p}{\partial z} = -\rho g + \rho \frac{\partial^2 u}{\partial t \partial x}(z + H).$$

We find the pressure by integration. If only the linear term is retained, thus is

$$p = \rho g(\eta - z) + \rho \frac{\partial^2 u}{\partial t \partial x} \left(\frac{1}{2}z^2 + Hz \right) + p_0.$$

With the expression for p , the linearized equation for horizontal motion can be written

$$\frac{\partial u}{\partial t} = -g \frac{\partial \eta}{\partial x} - \frac{\partial^3 u}{\partial t \partial x^2} \left(\frac{1}{2}z^2 + Hz \right).$$

Integration of this equation in the interval from $z = -H$ to $z = 0$, gives

$$\frac{\partial U}{\partial t} = -c_0^2 \frac{\partial \eta}{\partial x} + \frac{H^2}{3} \frac{\partial^3 U}{\partial t \partial x^2} \quad (2.87)$$

where the second term in the right side of equation (2.87) represents a correction term for a deviation from the hydrostatic distribution of pressure. Equation (2.87) together with the continuity equation (2.84) (with $\frac{\partial V}{\partial y} = 0$) has a wave solution of the form

$$\begin{aligned} \eta &= a \sin k(x - ct) \\ U &= ac \sin k(x - ct) \end{aligned}$$

where the phase speed is

$$c = \frac{c_0}{\left(1 + \frac{(kH)^2}{3}\right)^{\frac{1}{2}}} \simeq c_0 \left(1 - \frac{(kH)^2}{6}\right). \quad (2.88)$$

This shows that the correction term in equation (2.87) leads to dispersive waves, and the dispersion relation (2.88) is in agreement with the one we have found earlier for long waves (equation 2.19).

The condition that $kH \ll 1$ must be met for one to be able to calculate with the hydrostatic distribution of pressure. If this requirement is fulfilled, then the term $\frac{H^2}{3} \frac{\partial^3 U}{\partial t \partial x^2}$ in equation (2.87) is much smaller than the term $\frac{\partial U}{\partial t}$. This is seen when you calculate the terms with the help of the solution of this equation.

Until now we have assumed that the amplitude is so small that the equation of motion can be linearized. With the help of the linear solutions we have already found, we can easily find the conditions for the linearized solutions to be valid. Linearization implies, for example, that the term $u \frac{\partial u}{\partial x}$ is removed in comparison with $\frac{\partial u}{\partial t}$. The relationship between the first and last of these terms is maximum at a/H . The nonlinear term can therefore be easily cut away from the relation when $a/H \ll 1$. This is in good agreement with what we have found earlier in section 2.2. The condition $a/H \ll 1$ will also entail that the nonlinear term $u \frac{\partial w}{\partial x}$ can be cut away in relation to $\frac{\partial w}{\partial t}$ in the equation for vertical motion.

If the wavelength is sufficiently larger in comparison with H , then we can set the removed term $\frac{\partial w}{\partial t}$ in the with respect to g and calculate with the hydrostatic pressure distribution for waves with comparatively large amplitudes. If the wave amplitude is so large that one must use the nonlinear term in the equation, the requirement that the distribution of pressure is hydrostatic and that the horizontal velocity is independent of z will be valid, with good approximation, for waves which are sufficiently long in comparison with the depth. If one only takes with them the dominating nonlinear term, one finds from the equation of motion for horizontal motion

$$\frac{\partial u}{\partial t} + u \frac{\partial u}{\partial x} = -g \frac{\partial \eta}{\partial x} \quad (2.89)$$

and from the continuity equation

$$\frac{\partial \eta}{\partial t} = -\frac{\partial}{\partial x} [u(H + \eta)]. \quad (2.90)$$

The equations (2.89) and (2.90) describe the motion of nonlinear plane waves in shallow water. These equations will be discussed again in section 7.1.

The correction term for the perturbation from the hydrostatic distribution of pressure (see equation 2.87) can be of the same order of magnitude as the nonlinear term $u \frac{\partial u}{\partial x}$, if the parameter $\frac{a}{H} \left(\frac{\lambda}{H}\right)^2$ is around 10. In such cases, the nonlinear and the nonhydrostatic effects are of equally large importance, and an equivalent correction term must be picked up within the nonlinear shallow water equation (2.89). For two-dimensional motion, one finds that in this case, the shallow water equation can be written

$$\frac{\partial U}{\partial t} + \frac{\partial}{\partial x} \left(\frac{U^2}{h + \eta} \right) = -g(h + \eta) \frac{\partial \eta}{\partial x} + \frac{H^2}{3} \frac{\partial^3 U}{\partial t \partial x^2}. \quad (2.91)$$

Equation (2.91) together with equation (2.84) are called Boussinesq equations. The parameter $\frac{a}{H}(\frac{\lambda}{H})^2$ plays an important role by classifying long waves, and this is called the *Ursell-parameter*.

The shallow water equation can be derived by a formal perturbation expansion where the parameters

$$\alpha = \frac{a}{H} \quad \text{og} \quad \beta = \frac{\lambda}{H}$$

act as generation parameters. This procedure is described in Whitham (1974). Here we have attempted to choose a less mathematically formal presentation. The payoff comes from the physical interpretation of the various approximations evident from the presentation. In the next chapter, we present a formal description of the Boussinesq and KdV-equations.

We shall, at the end, see how the linearized shallow water equation can be used to study the propagation of plane waves over a slanted bottom. The relative change in water depth is assumed to be small over a distance which corresponds to the wavelength. We set

$$H = \alpha x$$

where $\alpha = \tan \theta$, and θ is the bottom plate's angle of incline with the horizontal plane (x -axis).

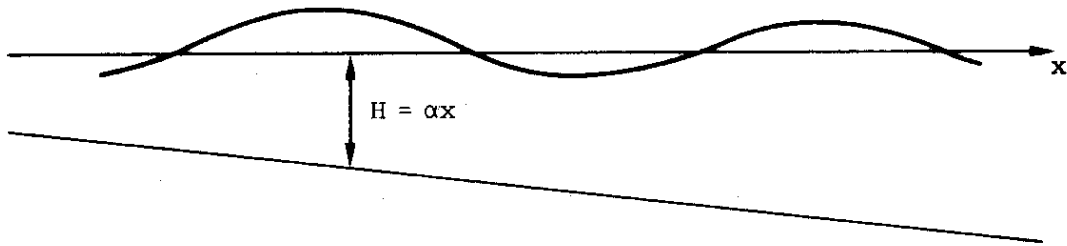

Figure 2.23: Waves on a slanted bottom.

We search for a solution of (2.86) which is periodic in t such that

$$\eta = \hat{\eta}(x) \cos \omega t.$$

Setting in (2.86) gives the following equation for $\hat{\eta}$

$$\frac{\partial}{\partial x} \left(x \frac{\partial \hat{\eta}}{\partial x} \right) + \kappa \hat{\eta} = 0 \quad (2.92)$$

where $\kappa = \omega^2/\alpha g$. This is the lesser of two strategies to solve equation (2.92). One strategy is to write $\hat{\eta}$ in a power series in x

$$\hat{\eta} = \sum_{n=0}^{\infty} a_n x^n.$$

Setting in the equation for $\hat{\eta}$ gives this, since the coefficients before every single power of x must zero for the equation to be fulfilled,

$$a_n = \frac{\kappa}{n^2} a_{n-1}.$$

The series for $\hat{\eta}$ can therefore be written

$$\hat{\eta} = a_0 \left[1 - \frac{\kappa x}{1^2} + \frac{(\kappa x)^2}{1^2 \cdot 2^2} - \dots \right].$$

This is a series for a Bessel-function J_0 of order zero and argument $2\sqrt{\kappa x}$ (see Rottmann) such that

$$\hat{\eta} = a_0 J_0(2\sqrt{\kappa x}). \tag{2.93}$$

Another strategy to find the solution to equation (2.92) is done by substituting $u = 2\sqrt{\kappa x}$. This brings the equation over to the form

$$u \frac{\partial^2 \hat{\eta}}{\partial u^2} + \frac{\partial \hat{\eta}}{\partial u} + u \hat{\eta} = 0$$

which is a Bessel equation in the standard form. Following, we have the general solution of the form

$$\hat{\eta} = a J_0(u) + b Y_0(u).$$

The graph for the function $J_0(2\sqrt{\kappa x})$ is sketched in figure 2.24.

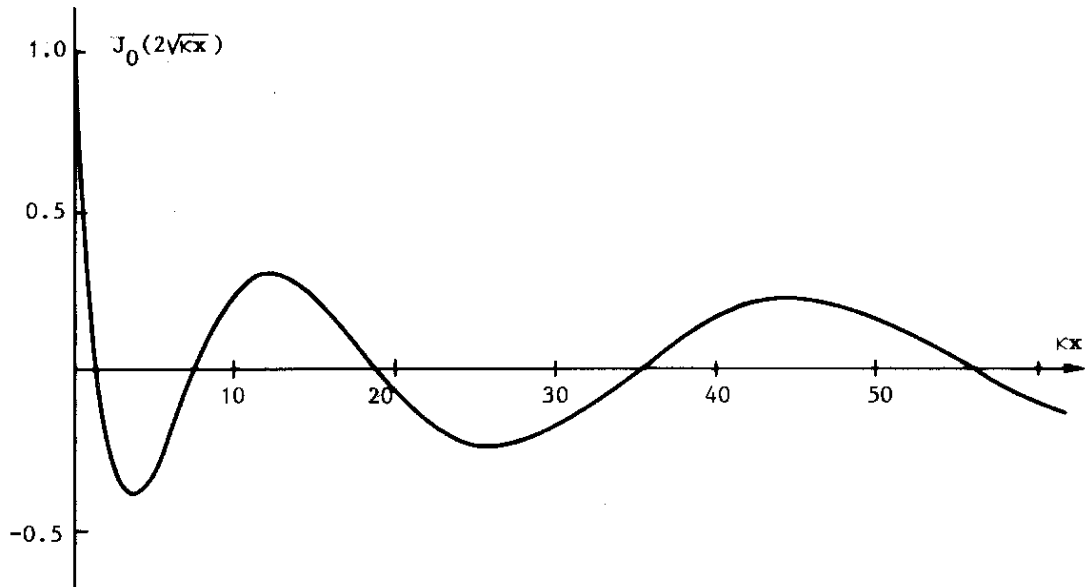

Figure 2.24: Wave profile for a slanted bottom.

For large values of the argument, z , the Bessel-function can be substituted with the first term in the asymptotic expression (see K. Rottmann 1960)

$$J_0(z) \sim \sqrt{\frac{2}{\pi z}} \cos\left(z - \frac{\pi}{4}\right).$$

We find therefore that for $\sqrt{\kappa x} \gg 1$ so is

$$\hat{\eta} = \frac{a_0}{\sqrt{\pi \kappa^{1/4} x^{1/4}}} \cos\left(2\sqrt{\kappa x} - \frac{\pi}{4}\right).$$

Thereby the surface displacement can be written

$$\eta = a(x) \cos\left(2\sqrt{\kappa x} + \omega t - \frac{\pi}{4}\right) + a(x) \cos\left(2\sqrt{\kappa x} - \omega t - \frac{\pi}{4}\right) \quad (2.94)$$

where

$$a(x) = \frac{a_0}{2\sqrt{\pi \kappa^{1/4} x^{1/4}}}.$$

The series expansion of the phase function $\chi = 2\sqrt{\kappa x} \pm \omega t - \frac{\pi}{4}$ in a power series in x (see the equivalent generation on page 39) leads to the following expression for wavelength in the region of the point $x = x_0$

$$\lambda = 2\pi \sqrt{\frac{x_0}{\kappa}}.$$

The expression (2.94) shows that the periodic motion consists of two wave components with amplitude a , which move, respectively, in the positive and negative x -directions. For the wave components which move into shallow water, the wave amplitude increases while at the same time, the wavelength decreases.

Exercises

1. Show that the linearized Boussinesq equation leads to a phase speed

$$c = \frac{c_0}{\left(1 + \frac{(kH)^2}{3}\right)^{\frac{1}{2}}}$$

Make a joint equation between the values for c intended to be a basis for these expressions and a basis for the exact expression for phase speed for gravity waves. How large must the wavelength be in comparison with the water depth for the perturbation to be less than 5%? Undertake a similarly joint equation when the phase speed is $c = c_0$.

2. In an infinitely long canal with a plane bottom and side walls which are parallel to each other, water depth is H when the water is at rest, and the width of the canal is B . We set the x -axis along the canal's middle and the

y -axis perpendicular to this at the sidewalls. Assume that $kH \ll 1$, and show that waves with surface displacement

$$\eta = \hat{\eta}(y)e^{i(kx - \omega t)}$$

are only valid under the given conditions. Determine $\hat{\eta}(y)$, and show that wave motion can be thought of the same way for waves that reflect from the side walls.

3. We assume two-dimensional wave motion in a fluid layer where the bottom is a plain and the depth is H . On the bottom there lies a submerged block with height h and length L . Towards the block a sinusoidal wave with amplitude a and wave length λ . Find the amplitude for the wave that is reflected by the block, and the wave that propagates into the area behind the block. We assume that the linearized hydrostatic shallow water theory is valid for the entire area. Find the maximum force that works on the block in the horizontal direction. Insert values characteristic for the foundation for the oil platform Statfjord C: $h = 60\text{m}$, $L = 150\text{m}$ and long period swell $\lambda = 800\text{m}$ and $a = 1\text{m}$. The water depth is $H = 150\text{m}$. Determine the force on the foundation. What are the primary reasons that this estimate must be presumed to be laden with large errors?

4. **Reflection from a shelf.**

A bottom profile is given as

$$h = \begin{cases} h_1 & x < 0 \\ h_2 & x > 0 \end{cases}$$

We assume a linear hydrostatic shallow water theory is applicable both to the right and to the left of the shelf ($x = 0$). At the shelf we assume that the surface displacement and mass flux is continuous.

A sinusoidal wave with amplitude A and frequency ω arrives towards the shelf from the left. Find the reflected and the transmitted waves.

5. **Reflection from a slanting wall.**

We have given a depth function

$$h = \begin{cases} h_1 & x < 0 \\ h_1 - \frac{x}{L}(h_1 - h_2) & 0 < x < L \\ h_2 & x > L \end{cases}$$

We assume that a linear hydrostatic shallow water theory is applicable for all x . From the area to the left of the bottom variations, $x < 0$, there

approaches a sinus formed wave with amplitude A and frequency ω . Find the resulting wave system.

You will have to derive the two linearly independent solutions of Bessels differential equations to the zeroth order:

$$\frac{\partial J_0}{\partial x} = -J_1, \quad \frac{\partial Y_0}{\partial x} = -Y_1.$$

To draft different border conditions you will need the equations

$$J_n(x) \sim \sqrt{\frac{2}{\pi x}} \cos\left(x - \frac{\pi}{4} - n\frac{\pi}{2}\right), \quad Y_n(x) \sim \sqrt{\frac{2}{\pi x}} \sin\left(x - \frac{\pi}{4} - n\frac{\pi}{2}\right),$$

for store x og

$$J_0(x) \sim 1, \quad J_1(x) \sim \frac{1}{2}x, \quad Y_0(x) \sim \frac{2}{\pi} \ln x, \quad Y_1(x) \sim -\frac{2}{\pi x},$$

for små x .

6. Reflection of a pulse from a shelf.

A bottom profile is given as

$$h = \begin{cases} h_1 & x < 0 \\ h_2 & x > 0 \end{cases}$$

We assume that linear, hydrostatic shallow water theory is applicable on both sides of the shelf ($x = 0$). A wave pulse approaches from the left and is given as

$$\eta(s) = \begin{cases} 0 & s < -L \\ A \cos^2\left(\pi \frac{s}{2L}\right) & -L < s < L \\ 0 & L < s \end{cases}$$

where $s = x - c_1 t$. We assume that the pulse, after its interaction with the shelf, is split into a transmitted and a reflected pulse. We further assume that both of the pulses have a form similar to the original pulse, but with other values for L and A . What wave lengths should these pulses have? Find the amplitudes by demanding conservation of mass and energy.

7. Energy transference in long waves on shallow water.

We shall in this exercise assume non-linear long wave theory.

- (a) Find the energy density E per horizontal surface unit by direct calculation. (Energy in vertical columns of water.)

- (b) Find the horizontal components of the energy flux \mathbf{F} integrated over the entire depth.
- (c) What relation must exist between E and \mathbf{F} ? Show by insertion that this is correct in this case.
- (d) We now assume a flat bottom, linear relations and a harmonic, progressive wave.
Show how centered versions of E and \mathbf{F} now can be related using the group velocity.

2.11 Derivation of nonlinear shallow water equations

2.11.1 Derivation of Boussinesq equations

We assume two dimensional motion with the x -axis horizontal and the z -axis vertical. The bottom is variable and described by $z^* = -h^*(x^*)$, where \star denotes magnitudes with dimension. We can make the equation dimensionless with the following points:

- A typical depth, H , is used for scaling the vertical magnitude, for which z is the vertical velocity and surface displacement.
- A typical wavelength, ℓ , is used to scale the horizontal magnitudes.
- The field dimension scales in addition with a factor, α , which is a designation for the amplitude.

Linearization assumed that when α is small, long wave generation is constructed in that

$$\epsilon \equiv \frac{H^2}{\ell^2} \quad (2.95)$$

w is small. We implement below a generation of these parameters. It is worth noting that we will not introduce formal perturbation series for the unknowns, but instead iterate in the equations.

Dimensioning makes after

$$\begin{aligned} z^* &= Hz & x^* &= \ell x & t^* &= \ell(gH)^{-\frac{1}{2}}t \\ h^* &= Hh(x) & \eta^* &= \alpha H\eta & u^* &= \alpha(gH)^{\frac{1}{2}}u \\ w^* &= \epsilon^{\frac{1}{2}}\alpha(gH)^{\frac{1}{2}}w & p^* &= \rho gHp \end{aligned}$$

The boundary conditions at $z = \alpha\eta$ can now be written

$$p = 0, \quad \eta_t + \alpha u \eta_x = w. \quad (2.96)$$

At the bottom we have the condition that for around zero fluid throughput, which gives

$$w = -h_x u. \quad (2.97)$$

In the space of the fluid we have Euler's equations of motion

$$u_t + \alpha u u_x + \alpha w u_z = -\alpha^{-1} p_x \quad (2.98)$$

$$\epsilon(w_t + \alpha w w_x + \alpha w w_z) = -\alpha^{-1}(p_z + 1) \quad (2.99)$$

and continuity equations

$$u_x + w_z = 0. \quad (2.100)$$

Eliminating all of the terms of order ϵ , we find the hydrostatic description. Eliminating all of the terms to the order ϵ^0 gives (2.99) a distribution of pressure

$$p = \alpha\eta - z + O(\alpha\epsilon) \quad (2.101)$$

which implies that $p_x = \alpha\eta_x + O(\alpha\epsilon)$, i.e. that the horizontal pressure gradient is independent of z to the order ϵ^0 . It follows that all of the particles in a section $x=\text{constant}$, have the same horizontal acceleration. They have the same horizontal velocity to the order ϵ^0 at a point in time, and this is valid for all time points. This is the case when the fluid is initially at rest. We can now write

$$u_z = O(\epsilon) \quad (2.102)$$

or $u \approx u(x, t)$. This can also be seen by using the requirements on angular frequency. Equation (2.98) gives

$$u_t + \alpha u u_x = -\eta_x + O(\epsilon). \quad (2.103)$$

We will now derive a higher order equation by assuming that both ϵ and α are small. This means that we retain the terms of order α and ϵ , but the terms which contain products of these or ϵ^2 can be dropped. We start by defining a vertical average

$$\bar{u} = (h + \alpha\eta)^{-1} \int_{-h}^{\alpha\eta} u \, dz. \quad (2.104)$$

A consequence of (2.102) is that $\bar{u}(x, t) - u(x, z, t) = O(\epsilon)$. An average depth continuity equation can now be written

$$\eta_t = -\{(h + \alpha\eta)\bar{u}\}_x. \quad (2.105)$$

This is exact and is derived and emerges from a direct volume view.

A correction to the hydrostatic pressure can be found from (2.99). We can make a correction of the order ϵ and α into the parenthesis in the left side, without

that, the pressure finds the relative corrections of the lower orders in $\alpha\epsilon$ and ϵ^2 . First we must find an expression for w . From (2.96), (2.102) og (2.100) follows

$$w = \eta_t - z\bar{u}_x + O(\alpha, \epsilon). \quad (2.106)$$

Setting these into (2.99) we find

$$p = \alpha\eta - z - \epsilon\alpha(z\eta_{tt} - \frac{1}{2}z^2\bar{u}_{xt}) + O(\alpha\epsilon^2, \alpha^2\epsilon). \quad (2.107)$$

From (2.105) we have $\eta_{tt} = -(h\bar{u})_{xt} + O(\alpha)$ which can be used to write the expressions for p . The next step is to average the horizontal components of the equation of motion, (2.98) over the fluid depth. Averaging the first term in the left side gives

$$\overline{(u_t)} = (h + \alpha\eta)^{-1} \int_{-h}^{\alpha\eta} u_t dz = \bar{u}_t + \alpha(h + \alpha\eta)^{-1}(\bar{u} - u|_{z=\alpha\eta})\eta_t. \quad (2.108)$$

Equation (2.102) now gives the last terms of order $\alpha\epsilon$ which can be dropped. For the next term in (2.98) we find equivalently

$$\overline{\left(\frac{1}{2}\alpha(u^2)_x\right)} = \alpha\frac{1}{2}\left(\overline{(u^2)}\right)_x + O(\alpha^2\epsilon). \quad (2.109)$$

A consequence of (2.102) is that we can write $u = \bar{u} + \epsilon u_1$ where u_1 is of order 1, but the average is zero. A simple calculation gives

$$\frac{1}{2}\left(\overline{(u^2)}\right)_x = \frac{1}{2}\overline{(\bar{u}^2 + 2\epsilon\bar{u}u_1)}_x + O(\epsilon^2) = \bar{u}\bar{u}_x + O(\epsilon)^2. \quad (2.110)$$

The last contribution to acceleration in (2.98) can be dropped immediately; this follows from (2.102). We set in p from (2.107) in the left side, and by averaging these we find

$$\bar{u}_t + \alpha\bar{u}\bar{u}_x = -\eta_x + \epsilon\left\{\frac{1}{2}h(h\bar{u}_t)_{xx} - \frac{1}{6}h^2\bar{u}_{xxt}\right\} + O(\epsilon^2, \alpha\epsilon). \quad (2.111)$$

These together with (2.105) constitute a set of two equations in x and t for the unknowns η and \bar{u} . The equations can be brought about by many forms of circumscription of the higher order terms or by, for example, introducing $U = (h + \alpha\eta)\bar{u}$ which is unknown. Notice that (2.111) is valid for variable depth. The new principal in (2.111) relates to hydrostatic theory in that the new term in the right side gives dispersion.

2.11.2 Derivation of KdV-equation

If waves are propagating in one direction on constant depth, the Boussinesq-equations can be replaced by the KdV (Korteweg–de Vries) equation. This equation can be derived in several ways;

1. Use a nonlinear term from hydrostatic nonlinear theory and the leading term in the dispersion from the linear dispersion relation. These can be combined directly.
2. Change the coordinate system such as it propagates with linear shallow water speed c_0 . For one-directional waves all scalars will change slowly in time in this system.
3. Find corrections for Riemann-invariants within the framework of Boussinesq-equations.

Method 1 will be scrutinized later, but here method 2 will be derived in detail.

We will do two things: description with only η as a unknown and reduce the order of the equation. First, the change of coordinates:

$$\xi = x - t, \quad \tau = \epsilon t. \quad (2.112)$$

The wave propagates towards increasing x and the small factor ϵ in front of t denotes the slowly time variation in the new coordinate system.

We could have chosen α as ϵ for rescaling of the time and these parameters are of the same order. The change of coordinates in the continuity equation, (2.105), gives

$$\epsilon\eta_\tau - \eta_\xi = -(1 + \alpha\eta)\bar{u}_\xi - \alpha\bar{u}\eta_\xi. \quad (2.113)$$

Where $h \equiv 1$. To the leading order: $\eta_\xi = \bar{u}_\xi + O(\alpha, \epsilon)$. If η and \bar{u} are equal somewhere in the medium, will they always be similar to this order. This is the case if the wave, e.g. have finite length. The equation above can therefore be rewritten within the accuracy used herein

$$\epsilon\eta_\tau - \eta_\xi = -\bar{u}_\xi - 2\alpha\eta\eta_\xi + O(\epsilon^2, \alpha\epsilon). \quad (2.114)$$

Using this, most of \bar{u} can be eliminated in the transformed equation of motion. Into (2.111), followed by rewriting will give

$$\bar{u}_\xi = \eta_\xi + \epsilon\eta_\tau + \alpha\eta\eta_\xi + \frac{1}{3}\epsilon\eta_{\xi\xi\xi} + O(\epsilon^2, \alpha\epsilon). \quad (2.115)$$

Into (2.114) and rearrange we will find a variant of the KdV equation

$$\epsilon\eta_\tau + \frac{3}{2}\alpha\eta\eta_\xi + \frac{1}{6}\epsilon\eta_{\xi\xi\xi} = O(\epsilon^2, \alpha\epsilon). \quad (2.116)$$

We should note that $O(1)$ terms are cancelled such as this equation will express directly the link between slowly time variation, non-linearity and dispersion. It should also be noted that no cross-derivation was needed to eliminate \bar{u} such as a low order will automatically be found. Introduce the coordinates x and t in (2.116) we will find

$$\eta_t + (1 + \frac{3}{2}\alpha\eta)\eta_x + \frac{1}{6}\epsilon\eta_{xxx} = O(\epsilon^2, \alpha\epsilon), \quad (2.117)$$

which is the same as will be presented later. This can be rewritten in different ways. For example we can use the leading order balance in (2.117), $\eta_t + \eta_x = O(\epsilon, \alpha)$, to rewrite the dispersion term

$$\eta_t + (1 + \frac{3}{2}\alpha\eta)\eta_x - \frac{1}{6}\epsilon\eta_{xxt} = O(\epsilon^2, \alpha\epsilon), \quad (2.118)$$

which is better to solve numerically. The different variants of the KdV equation will not give the same answer, but solutions which is consistent within the common accuracy.

It is possible to generalize the KdV - equation such as a slowly varying floor ($h_x = O(\epsilon, \alpha)$) etc. can be included, but this is not shown herein.

2.12 Viskositetens innvirkning på overflatebølger

I det foregående har vi behandlet væsken som friksjonsfri og derved neglisjert viskositetens innvirkning på bølgebevegelsen. Selv om vi kan gjøre dette med god tilnærming for mange bølgefenomener, vil viskositeten i andre tilfeller kunne ha en dominerende innflytelse på bølgebevegelsen. Det er derfor god grunn til å se nærmere på den betydningen friksjonen har for overflatebølger.

Vi skal her nøye oss med å behandle plane overflatebølger i en homogen og inkompressibel Newtonsk væske av ubegrenset dyp. De lineariserte bevegelseslikningene er

$$\frac{\partial u}{\partial t} = -\frac{1}{\rho}\frac{\partial p}{\partial x} + \nu\nabla^2 u \quad (2.119)$$

$$\frac{\partial w}{\partial t} = -\frac{1}{\rho}\frac{\partial p}{\partial z} + \nu\nabla^2 w - g \quad (2.120)$$

og kontinuitetslikningen

$$\frac{\partial u}{\partial x} + \frac{\partial w}{\partial z} = 0.$$

I disse likningene, og i følgende likninger i dette avsnittet, betegner ∇^2 den to-dimensjonale Laplace operatoren

$$\nabla^2 = \frac{\partial^2}{\partial x^2} + \frac{\partial^2}{\partial z^2}.$$

ν er den kinematiske viskositetskoeffisienten.

Vi innfører potensialene ϕ og ψ og setter

$$u = \frac{\partial\phi}{\partial x} - \frac{\partial\psi}{\partial z}, \quad w = \frac{\partial\phi}{\partial z} + \frac{\partial\psi}{\partial x}. \quad (2.121)$$

Både virvellikningen (som finnes ved å eliminere trykket fra (2.119) og (2.120)) og kontinuitetslikningen er oppfylt dersom

$$\frac{\partial\psi}{\partial t} - \nu\nabla^2\psi = 0 \quad (2.122)$$

og

$$\nabla^2\phi = 0. \quad (2.123)$$

Derved følger det fra (2.119) og (2.120) at trykket p kan skrives

$$p = -\rho\left(\frac{\partial\phi}{\partial t} + gz\right) + f(t)$$

hvor $f(t)$ er en vilkårlig funksjon av t som vi kan trekke inn i ϕ . Benytter vi så resultatene fra avsnitt 2.1, får de lineariserte grenseflatebetingelsene ved overflaten formen

$$\begin{aligned} \frac{\partial u}{\partial z} + \frac{\partial w}{\partial x} &= 0 \\ \frac{\partial\phi}{\partial t} + g\eta + 2\nu\frac{\partial w}{\partial z} - \frac{\sigma}{\rho}\frac{\partial^2}{\partial x^2} &= 0 \\ \frac{\partial\eta}{\partial t} &= w \end{aligned} \quad (2.124)$$

hvor man i alle tre likningene skal sette $z = 0$. Den første av disse likningene uttrykker at skjærspenningen er null ved overflaten, den neste likningen er betingelsen for normalspenningen og den siste er den kinematiske betingelsen. Av de to siste likningene kan overflatehevningen elimineres, og en får

$$\frac{\partial^2\phi}{\partial t^2} + gw + 2\nu\frac{\partial^2 w}{\partial z\partial t} - \frac{\sigma}{\rho}\frac{\partial^2 w}{\partial x^2} = 0 \quad (2.125)$$

for $z = 0$.

Likningene (2.122) og (2.123) har løsninger

$$\begin{aligned} \psi &= Ae^{mz}e^{i(kx-\omega t)} \\ \phi &= Be^{kz}e^{i(kx-\omega t)} \end{aligned} \quad (2.126)$$

hvor A , B , k og ω er konstanter og

$$m = \left(k^2 - \frac{i\omega}{\nu}\right)^{\frac{1}{2}}$$

λ cm	$\beta \times 10^3$	z_e cm
1	5.01	0.01
10	0.31	0.03
100	0.01	0.05
1000	0.0001	0.09

Table 2.1: Dempning ved forskjellige bølgelengder.

For at bevegelsen skal dø ut nå $z \rightarrow -\infty$ velger vi realdelen av m positiv. De tilhørende hastighetskomponenter finnes ved at uttrykkene (2.126) settes inn i (2.121). Den første grenseflatebetingelsen i (2.124) sammen med betingelsen (2.125) leder til et homogent likningssett for konstantene A og B . Skal dette settet ha ikke-trivielle løsninger for A og B , må determinanten være null, og dette medfører at følgende betingelse må være oppfylt:

$$\left(\frac{c}{c_s} + i\beta\right)^2 - 1 + \beta^{3/2}\left(\beta - 2i\frac{c}{c_s}\right)^{\frac{1}{2}} = 0 \quad (2.127)$$

hvor $c_s = \left(\frac{g}{k} + k\frac{\sigma}{\rho}\right)^{\frac{1}{2}}$ er fasehastigheten for tyngde-kapillarbølger i friksjonsfri væske ($\nu = 0$) og c betegner som før fasehastigheten ω/k .

Parameteren β som inngår i likning (2.127) er gitt ved

$$\beta = \frac{2\nu k}{c_s}.$$

For væsker med liten viskositet er β meget liten unntatt for svært korte bølgelengder. Tabell 2.1 viser noen verdier av β for rent vann ($\sigma = 7.4 \cdot 10^{-2}\text{N/m}$, $\nu = 10^{-6}\text{m}^2/\text{s}$).

Dersom man unntar de svært korte bølgelengdene, kan man sløyfe leddet som har $\beta^{3/2}$ som faktor i likning (2.127), og vi får

$$c = c_s(1 - i\beta).$$

For et reelt bølgetall er altså fasehastigheten kompleks. Realverdien av c er fasehastigheten for bølgene, mens imaginærdelen tilsvarer en eksponensiell dempning. Benytter man seg av resultatene ovenfor, kan overflatehevningen skrives

$$\eta = ae^{-2\nu k^2 t} \cos k(x - c_s t).$$

Dette uttrykket viser at forplantningshastigheten er upåvirket av friksjonen, men at friksjonen medfører en dempning av bølgeamplituden som er størst for korte bølger. e-foldingstiden for dempningen er

$$t_e = \frac{1}{2\nu k^2} = \frac{\lambda^2}{8\pi^2\nu}.$$

Siden perioden for bølgene er $T = 2\pi/kc_s$ så tilsvarer e-foldingstiden et antall perioder

$$\frac{t_e}{T} = \frac{1}{4\pi} \left(\frac{c_s}{\nu k} \right) = \frac{1}{2\pi\beta}.$$

Selv for så korte bølger som $\lambda = 1\text{cm}$ er e-foldingstiden i vann omkring 30 perioder. Med andre ord etter at bølgene har forplantet seg en strekning på 30λ er amplituden redusert med en faktor e^{-1} .

For tilstrekkelig små verdier av β er

$$m = \pm \frac{k}{\beta^{\frac{1}{2}}}(1 - i).$$

Potensialet ψ som angir hvordan det virvelfrie hastighetsfeltet blir deformert av friksjonens virkning, vil i dette tilfellet inneholde en dempningsfaktor $\exp(\frac{z}{z_e})$ hvor

$$z_e = \frac{\beta^{\frac{1}{2}}\lambda}{2\pi}.$$

Hastighetsfeltet er derfor bare merkbart påvirket av friksjonen i en tynn sone av tykkelse z_e nær overflaten. Noen tallverdier for z_e for overflatebølger i vann er gitt i tabell 2.1. Regningene ovenfor viser at friksjonen har liten betydning for lange bølger, og e-foldingstiden t_e vokser over alle grenser når $k \rightarrow 0$. Derksom væskedypet er begrenset, vil imidlertid de lengste bølgene skape betydelige hastigheter nær bunnen. På grunn av friksjonen vil det også utvikles et grensesjikt ved bunnen som får betydning for bølgenes dempning. Det er mulig å estimere virkningen av dette, men vi vil ikke gå nærmere inn på det her.

2.13 Svingninger i basseng

For lineær bølgebevegelse vil en sum av bølgekomponenter også være en mulig løsning av likningene. Stående svingninger fremkommer ved å addere bølgekomponenter som forplanter seg i motsatt retning i forhold til hverandre. Adderer man til bølgekomponenten gitt ved (2.14) en annen bølgekomponent med bølgetall $-k$ og amplitude a , får man

$$\begin{aligned} \eta &= A \cos kx \sin \omega t \\ \phi &= \frac{A\omega}{k \sinh kH} \cosh k(z + H) \cos kx \cos \omega t \end{aligned}$$

hvor $A = -2a$. Krever man så at horisontalhastigheten skal være null ved vertikale plan ved $x = 0$ og $x = L$, medfører dette at bevegelsen bare er mulig når bølgetallet har bestemte diskrete verdier k_n gitt ved

$$k_n L = n\pi$$

hvor $n = (1, 2, 3, \dots)$. Den tilhørende verdi av vinkelhastigheten ω_n finnes ved å sette $k = k_n$ i dispersjonsrelasjonen (2.15). For tyngdebølger får vi at

$$\omega_n = \left[g \frac{n\pi}{L} \tanh\left(\frac{n\pi H}{L}\right) \right]^{\frac{1}{2}}.$$

Derved kan man bestemme frekvens og periode for stående svingninger i et kar med horisontal bunn og vertikale vegger. Overflatehevingen ved tidspunktet $t = 0$ for de to laveste modene, grunntonen, $n = 1$, og overtonen, $n = 2$, er skissert på figur 2.25. Dersom $\frac{H}{L} \ll 1$, kan man for de laveste modene sette $\tanh\left(\frac{n\pi H}{L}\right) \simeq \frac{n\pi H}{L}$, og perioden for svingningen blir

$$T_n = \frac{2L}{nc_0}.$$

Dette viser at den største svingeperioden ($n = 1$) tilsvarer den tiden det tar for en bølge å gå frem og tilbake i bassenget.

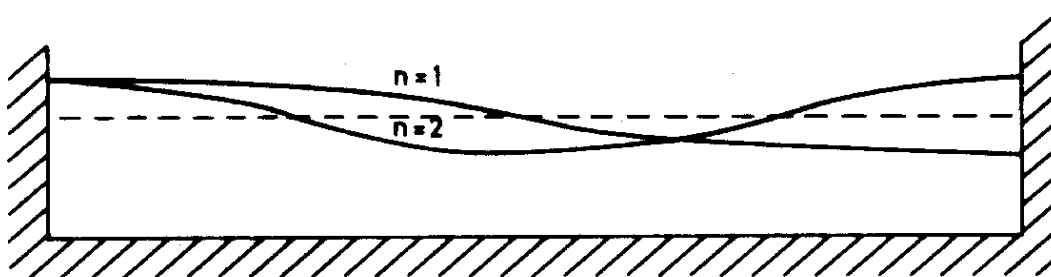

Figure 2.25: To laveste egenmoder i basseng.

Stående svingninger kan også opptre i basseng hvor dypet ikke er uniformt. Ut fra løsningene på side 54 kan man for eksempel finne perioden for stående svingninger i basseng med jevnt skrånende bunn. Det overlates til leseren å gjøre det. For mer kompliserte bassengformer kan det by på store matematiske vanskeligheter å bestemme perioden, men det finnes en rekke beregninger av perioden for forskjellige bassengformer. Interesserte henvises til en oversiktsartikkel av Miles (1974).

Stående svingninger av den arten som her er beskrevet, opptrer i innsjøer og havnebasseng. I innsjøer er det som regel vind som fører til at svingningene blir satt i gang, men ras og jordskjelv kan også være årsaken. Etter et jordskjelv i India i 1950 ble det for eksempel observert svingninger i flere norske innsjøer og fjordarmer (Kvale 1955).

For svingninger i havnebasseng kompliseres analysen ved at bassenget er åpent til havet og at en del av energien kan lekke ut gjennom åpningen. Som eksempel

på hvordan svingeperioden kan bestemmes for åpne bassenger henvises til øving-soppgave 1 under dette avsnitt. Denne type svingninger har en klar analogi i akustiske svingninger i orgelpiper.

Svingningene i havner, eller drag som sjøfolk sier, oppstår som regel under visse værforhold, og svingningen får antagelig sin energi fra periodiske forstyrrelser i havet utenfor bassenget. Svingningene innvirker på havneforholdene og har derfor betydelig praktisk interesse. Undersøkelser av svingninger i to norske havner, Sørvær i Finnmark og Sirevåg i Rogaland, er beskrevet av Viggosson og Rye (1971) og av Gjertveit (1971). I figur 2.26 er det vist registreringer av svingninger i Sørvær havn. Amplituden i svingningene er opptil 0.8m, og svingetiden er omkring 6min.

Exercises

1. En to-dimensjonal modell av en havn kan tenkes å bestå av et gruntvannsområde av lengde b og med uniformt dyp h og et ubegrenset dyphav med uniformt dyp H . Vi skal undersøke muligheten for langperiodiske svingninger i havna samtidig med at det forplanter seg bølger utover i dyphavet. Vi forutsetter at svingningene er langperiodiske og bruker den lineariserte og hydrostatiske gruntvannsteorien. I havneområdet settes overflatehevningen til

$$\eta = \hat{\eta}(x)e^{i\omega t}$$

hvor x regnes utover fra kysten og ω er vinkelhastigheten og $\hat{\eta}(x)$ er en funksjon av x . I dyphav er

$$\eta = ae^{i(kx - \omega t)}$$

hvor bølgetallet $k = \omega/c_2$ og amplituden a er bestemt av amplituden for svingningene i havna. Vis at ω er bestemt ved

$$\tan\left(\frac{\omega b}{c_1}\right) = i\frac{c_2}{c_1}$$

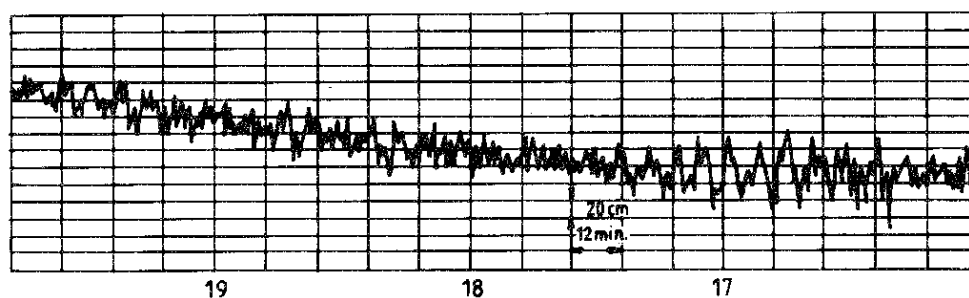

Figure 2.26: Registrering av svingninger i Sørvær havn. Avtegnet fra Viggosson og Rye.

hvor $c_1 = \sqrt{gh}$ og $c_2 = \sqrt{gH}$. Finn svingetiden når $h/H \ll 1$, og vis at man i dette tilfellet har en knute for svingningene ved utløpet av havna.

2. Vis at hastighetspotensialet

$$\phi = a[\sinh ky \sin kz + \sin ky \sinh kz] \cos \omega t$$

beskriver transversale svingninger i en kanal hvor sideveggene er rette linjer som danner en vinkel på 45° med vertikalen. Origo er lagt i kanalens dypeste punkt med y - og z -aksen henholdsvis horisontalt og vertikalt. Vis også at for grunnsvingningen er

$$\phi = ayz \cos \omega_1 t$$

og vinkelhastigheten er bestemt ved

$$\omega_1 = \sqrt{\frac{g}{H}}$$

H betegner høyde av vannspeilet over origo ved likevekt.

3. Svingninger i basseng

Et basseng har lengde L og konstant dyp h . Bølgebevegelsen i bassenget antas å være godt beskrevet ved lineær potensialteori. I bassengets endepunkter har η null normalderivert. (Hva betyr det fysisk?)

Initialbetingelsen er gitt ved

$$\eta(x, 0) = \frac{A}{f^4} (x + f)^2 (x - f)^2$$

for $-f < x < f$, $\eta(x, 0) = 0$ i resten av bassenget. Bevegelsen starter fra ro .

- Skisser initialbetingelsen og finn en passende Fourierrepresentasjon av $\eta(x, t)$. (Fourierkoeffisienter skal regnes ut).
- Sett $L = 200$ og $f = 10$. Beregn og plott overflateformene ved $t = 0.25 \frac{L}{\sqrt{gh}}$ for $h = 0.1$, $h = 1.0$, $h = 10.0$ og $h = 100.0$. Gjenta dette for $t = 0.75 \frac{L}{\sqrt{gh}}$.
- Sett $L = 0.03$, $h = 0.01$ og $f = 0.001$. Studer løsningen for ulike tidspunkter. Hvordan brytes pulsen opp?
- Kan denne løsningsmetoden generaliseres til tre dimensjoner. Forklar i så fall hvordan.

Chapter 3

GENERAL PROPERTIES OF PERIODIC AND NEARLY PERIODIC WAVE TRAINS

Previously we have seen examples of wave trains where the characteristics of the individual waves such as wavelength, frequency, and amplitude change very little from one wave to the next. The gradual changes arose from dispersion because of inhomogeneity in the medium. We have also seen that the viscosity can lead to gradual changes in the wave train.

Nearly periodic wave trains of this type often appear in nature, and these phenomena are, of course, not just tied to waves in fluids. To show this, we will look at an earthquake registered from five sensors at the seismic registration installation NORSAR (figure 3.1). The center of the installation is at Kjeller,

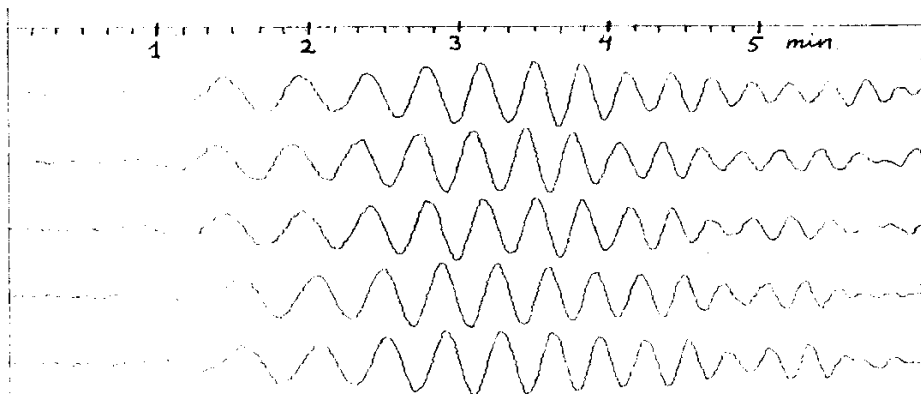

Figure 3.1: Seismograph

outside of Oslo, and the sensors were placed over the south-eastern part of Norway.

These waves are seismic waves (Rayleigh waves) which propagate along the earth's surface, and the waves, in this case, are due to an earthquake at the Azores. The regular wave train mainly arises from the dispersion.

3.1 Wave kinematics for one-dimensional wave propagation

We assume that at least one parameter (velocity, pressure, displacement, etc) which describes wave motion can be written in the form

$$A(x, t)e^{i\chi(x, t)}. \quad (3.1)$$

This implies that either the real or the imaginary parts of the equation above represent the physical magnitude. From the phase function χ we can determine k and ω by

$$k = \frac{\partial\chi}{\partial x} \quad \omega = -\frac{\partial\chi}{\partial t}. \quad (3.2)$$

k , ω and A are assumed to be slowly varying functions of x and t in the sense that they vary little over a distance comparable to a wavelength or over a time comparable to a period. k and ω thus represent local values for the wave number, angular velocity, and phase function is there for (modulus a constant) equal to

$$\chi = kx - \omega t.$$

From this, it is reasonable to assume that ω and k are locally connected by the dispersion relation. In an inhomogeneous medium where the phase speed changes slowly in the direction of wave propagation, ω will not only be dependant on k , but will also be a slowly varying function of x . If we also take into account that the properties of the medium change slowly in time, we can write

$$\omega = \omega(k, x, t).$$

For example, $\omega = k\sqrt{gH}$ is the dispersion relation for long waves in shallow water. With slowly varying water depth, $H = H(x)$, this becomes a relation of the type described above. As far as time dependence is concerned, it can appear in many forms. In section (5.5) we shall handle the case where surface waves propagate through a region that is time dependent in the tidal flow. This leads to a dispersion relation where time goes into it explicitly.

It follows from (3.2) that

$$\left(\frac{\partial k}{\partial t}\right)_x + \left(\frac{\partial \omega}{\partial x}\right)_t = 0 \quad (3.3)$$

Of reasons that will be apparent later, we have chosen to designate via indices which variables are kept constant during derivation. When $k/2\pi$ is the amount of

waves per unit of length and $\omega/2\pi$ is the amount of waves per unit of time, k and ω can be interpreted respectively as wave density and wave flux. Equation (3.3) therefore expresses that the number of waves within a certain interval changes due to the net flux of waves through the interval's end points. Taking the derivative of the dispersion relation with respect to x while holding t constant, we find

$$\left(\frac{\partial\omega}{\partial x}\right)_t = \left(\frac{\partial\omega}{\partial k}\right)_x \left(\frac{\partial k}{\partial x}\right)_t + \left(\frac{\partial\omega}{\partial x}\right)_k.$$

Setting in (3.3) gives

$$\left(\frac{\partial k}{\partial t}\right)_x + c_g \left(\frac{\partial k}{\partial x}\right)_t = -\left(\frac{\partial\omega}{\partial x}\right)_k \quad (3.4)$$

where $c_g = \frac{\partial\omega}{\partial k}$ is the group velocity.

In a homogeneous medium, the dispersion relation will not depend explicitly on x and $\frac{\partial\omega}{\partial x} = 0$. In this case, (3.4) simplifies to

$$\frac{\partial k}{\partial t} + c_g \frac{\partial k}{\partial x} = 0. \quad (3.5)$$

This shows that in a homogeneous medium, an observer that moves with group velocity will follow a wave with fixed wave number. If we consider a point with coordinate x which moves with group velocity, then

$$\frac{dx}{dt} = \frac{\partial\omega}{\partial k}. \quad (3.6)$$

Thereby (3.4) can be written

$$\frac{dk}{dt} = -\frac{\partial\omega}{\partial x} \quad (3.7)$$

which expresses the change in k with time at a point which moves with velocity c_g .

When ω is a function of k , x , and t

$$\frac{d\omega}{dt} = \left(\frac{\partial\omega}{\partial k}\right)_x \frac{dk}{dt} + \left(\frac{\partial\omega}{\partial x}\right)_k \frac{dx}{dt} + \frac{\partial\omega}{\partial t}.$$

By using (3.6) and (3.7) we find that

$$\frac{d\omega}{dt} = \frac{\partial\omega}{\partial t}.$$

In this case, it is important to underscore the differences in differential operators $\frac{d}{dt} = \frac{\partial}{\partial t} + c_g \frac{\partial}{\partial x}$ and $\frac{\partial}{\partial t}$.

If the medium does not change in time, ω is not explicitly dependent on t and $\frac{\partial\omega}{\partial t} = 0$. The equation above is found in this case in the form

$$\frac{d\omega}{dt} = 0. \quad (3.8)$$

The last equation shows that ω is constant when one moves with the group velocity. In other words: A wave with a definite period moves with a velocity that corresponds with the group velocity for this wave. This makes it feasible to determine the group velocity by observation. For the earthquake waves shown in figure 3.1, one can identify waves with periods from 15 to 35 seconds. If the occurrence time for the quake is known, the transit time, t_g , (i.e. the time the waves have used to get to the observation point from the epicenter) for the various wave periods can be determined. The waves will follow a path which lies close to a great circle through the epicenter and the observation place. If one knows the length, L , of the path, then the group velocity for the waves is

$$c_g = L/t_g.$$

It must be emphasized that since the group velocity can vary along the path, this method will find an average group velocity for the path.

We notice that equations (3.4) and (3.5) only give information on frequency and wave number, and thereby the phase function, but the wave amplitude is undetermined. For this reason, the term wave kinematics is often used for the theory and results which are attained by this method.

For a homogeneous medium where c_g is a function of k , equation (3.5) has a solution such that k is determined by

$$c_g = \frac{x}{t}. \quad (3.9)$$

This is correctly realized by differentiation of the last equations with respect to x and t such that the magnitudes $\frac{\partial k}{\partial t}$ and $\frac{\partial k}{\partial x}$ appear. The equation expresses that a wave component with a fixed wave number k which at time $t = 0$, starts from the origin $x = 0$, has propagated a distance x in the time t .

The expression (3.9) can be used to derive the results we have derived earlier after comprehensive analysis. This is valid for wave forms at a large offset from the disturbance that created the waves.

For gravity waves in deep water is

$$c_g = \frac{1}{2} \sqrt{\frac{g}{k}}$$

and with the help of (3.9), we find that

$$k = \frac{gt^2}{4x^2}.$$

The corresponding value for ω is

$$\omega = \frac{gt}{2x}.$$

This gives a phase function corresponding with what we have found for waves generated by an isolated disturbance (see equation 2.72).

With an equivalent method, we can find wave number, angular velocity, and phase function for capillary waves generated by an isolated disturbance. For capillary waves in deep water is

$$c_g = \frac{3}{2} \sqrt{\frac{\sigma k}{\rho}}$$

and (3.9) gives

$$k = \frac{4}{9} \frac{\rho}{\sigma} \frac{x^2}{t^2}.$$

It must be emphasized that this expression for k is valid when one is a long distance away from the initial disturbance.

As an example of the solution of equation (3.4) when $\frac{\partial \omega}{\partial x}$ is nonzero, we shall look at long gravity waves over a slanted bottom (see page 54). In this case is

$$\omega = \sqrt{\alpha g x} k.$$

We assume the stationary state is $\frac{\partial k}{\partial t} = 0$, and thereby is

$$\frac{\partial k}{\partial x} = -\frac{1}{2} \frac{k}{x}.$$

This equation has the solution

$$k = k_0 x^{-\frac{1}{2}}$$

where k_0 is a constant. We find that the results are in agreement with what we have found earlier.

Exercises

1. Wave generator; counting of crests

In one end of a wave tank, a wave is generated with length $\lambda = 1$ m. The wave generator has been on for 100 seconds. Estimate the number of wave crests in the channel in the three cases where the water depth is $h = 4$ m, $h = 0.5$ m and $h = 0.1$ m. Assume that the wave channel is long enough that reflection from the opposite end does not happen.

3.2 Hamiltons equations. Wave-particle analogy

Readers who have knowledge of classical mechanics will immediately recognize equations (3.6)–(3.8). The motion of a particle in a conservative field can be

described by Hamilton's equations

$$\begin{aligned}\frac{dq}{dt} &= \frac{\partial H}{\partial p} \\ \frac{dp}{dt} &= -\frac{\partial H}{\partial q} \\ \frac{dH}{dt} &= 0\end{aligned}\tag{3.10}$$

where q is the generalized coordinate, p is the generalized momentum, and H is the Hamiltonian function. In a conservative field, H is the particle's total energy. We see that the set of equations in (3.10) is of the same form as equations (3.6)–(3.8). Therefore there exists a formal analogy between particle motion and wave motion such that

x	corresponds to	q
k	corresponds to	p
ω	corresponds to	H

It was Einstein (1905) who first gave physical content to the formal analogy between particle motion and wave motion by setting the energy and quantity of motion for light particles (photons) to respectively $H = \hbar\omega$ and $p = \hbar k$ where \hbar is Planck's constant.

This is the foundation for the two complementary descriptions of light as particle motion and wave motion.

3.3 Wave kinematics for multi-dimensional wave propagation. Ray theory.

In the general case, the phase function will be dependent on the position vector \mathbf{r} such that $\chi = \chi(\mathbf{r}, t)$. In a method corresponding to what we have used in section 2.13, we can determine the local values for the wave number and angular velocity

$$\mathbf{k} = \nabla\chi \quad \text{og} \quad \omega = -\frac{\partial\chi}{\partial t}.$$

We assume that \mathbf{k} and ω are slowly varying functions of space and time coordinates. For a definite point in time the equation

$$\chi(\mathbf{r}, t) = \text{constant}$$

will represent a phase surface and the vector \mathbf{k} is normal to the surface. Because of the assumption that the functions vary slowly, the phase surface will bend faintly, see figure 3.2. The spatial curve that arises by setting

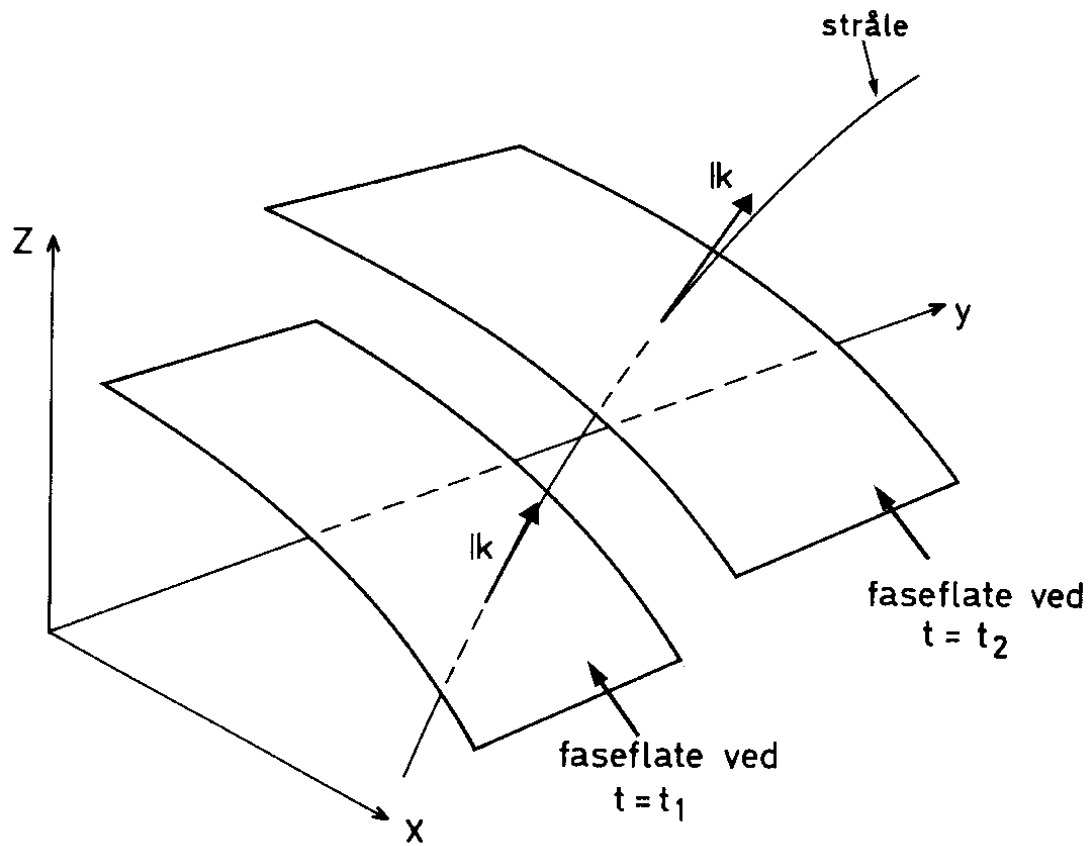

Figure 3.2: Rays and phase surface.

$$\mathbf{k} \times d\mathbf{r} = 0$$

where $d\mathbf{r}$ is a vectorial arch element for the curve, denotes a *ray*. The wave number vector is also tangent to the ray. In the one dimensional case, \mathbf{k} and ω are found by the dispersion relation, which in this case, we assume to be time independent

$$\omega = \omega(\mathbf{k}, \mathbf{r}). \quad (3.11)$$

The explicit dependence of \mathbf{r} is an expression for spatial inhomogeneity in the medium. The change over time of \mathbf{k} and ω at a point with coordinate \mathbf{r} , which moves with the group velocity, will be given by the equations for all of the coordinate directions

$$\begin{aligned} \frac{dx_i}{dt} &= \frac{\partial \omega}{\partial k_i} \\ \frac{dk_i}{dt} &= -\frac{\partial \omega}{\partial x_i} \\ \frac{d\omega}{dt} &= 0 \end{aligned} \quad (3.12)$$

where the indices $i = 1, 2, 3$ denote the vector components along the three axial directions. Equations (3.11) and (3.12) together with the initial conditions for x_i , k_i and ω designate a *wave path* (or particle path) $\mathbf{r}(t)$. The form of these equations is particularly well suited for numerical computations. In a medium with isotropic dispersion where ω is a function of $k = |\mathbf{k}|$, but not of the direction of \mathbf{k} , we find that

$$\frac{\partial \omega}{\partial k_i} = \frac{\partial \omega}{\partial k} \frac{\partial k}{\partial k_i} = \frac{\partial \omega}{\partial k} \frac{k_i}{k}.$$

This shows that for media with isotropic dispersion, the group velocity has the same direction as the wave number vector, and the wave path coincide in this case together with the rays.

We shall look at two examples in order to show explicit solutions of (3.12). The first deals with refraction of long waves in shallow water. We assume that the bathymetry is such that the water depth, H , is a function of x given by

$$c(x) = \sqrt{gH(x)}.$$

The dispersion relation can be written

$$\omega = c(x)k.$$

Since the propagation velocity depends on depth, the waves will refract. If the water depth increases with x , the rays will be as sketched in figure 3.3. We designate the wave number vector components along the x - and y -axes with k_x and k_y respectively. From equation (3.12) we find that along the ray is

$$\begin{aligned} \omega &= \text{constant} \\ k_y &= \text{constant} \\ k_x &= \pm \left(\frac{\omega^2}{c^2(x)} - k_y^2 \right)^{\frac{1}{2}} \end{aligned}$$

For this case, which is sketched in the figure, one must select the minus sign in front of the square root in the last expression.

If the angle between the x -axis and the wave number vector is designated with θ , we find

$$\frac{\sin \theta}{c} = \frac{k_y}{kc} = \frac{k_y}{\omega} = \text{constant}$$

which shows that the refraction obeys *Snell's law*. The equation for rays is

$$\frac{dy}{dx} = \frac{k_y}{k_x}.$$

For special values of the function $H(x)$, one can find simple analytic expressions for rays. With refraction of this type, one can notice when the waves propagate

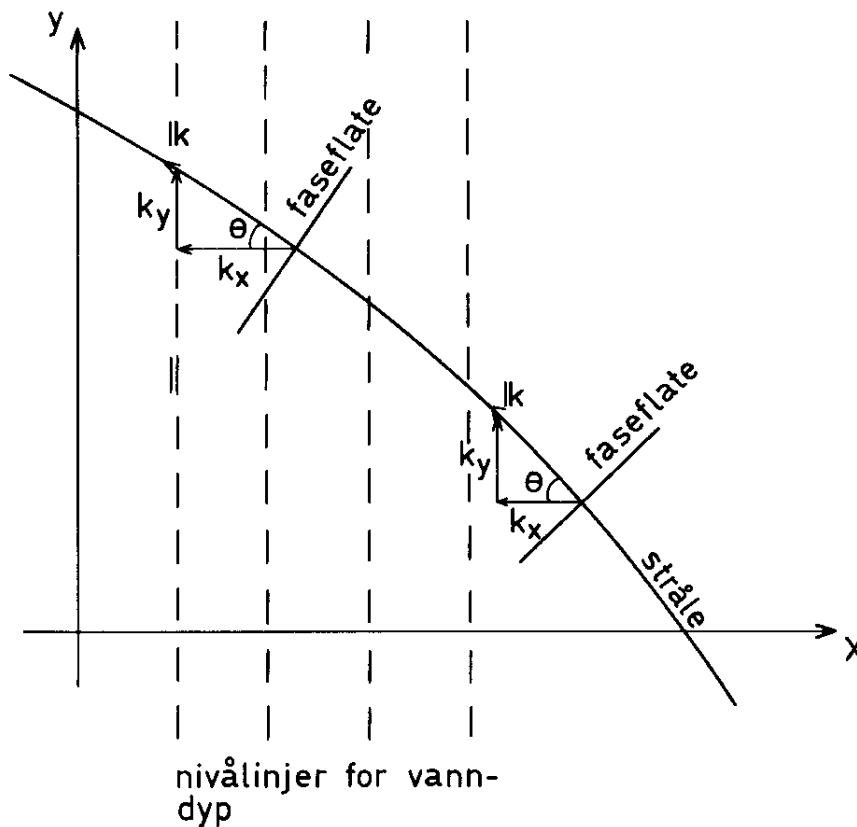

Figure 3.3: Refraction in shallow water.

in towards a straight coast with a slanted bottom. One will see that waves which come in on the slope relative to the bottom are deflected such that the crests are eventually parallel to the coast.

The next example of refraction is of seismic waves in a symmetric sphere. We assume that the velocity for the waves is a function of distance $r = |\mathbf{r}|$ from the sphere's center and that waves grow without dispersion such that

$$\omega = c(r)k.$$

This dispersion relation is valid within a good approximation for seismic waves which propagate along the earth. We find that with this dispersion relation

$$\frac{\partial \omega}{\partial x_j} = \frac{dc}{dr} \frac{x_j}{r} k, \quad \frac{\partial \omega}{\partial k_j} = c \frac{k_j}{k}.$$

From equation (3.12) it follows therefore that

$$\frac{d\mathbf{r}}{dt} = c \frac{\mathbf{k}}{k}, \quad \frac{d\mathbf{k}}{dt} = -\frac{dc}{dr} \frac{\mathbf{r}}{r} k,$$

where \mathbf{r} is the coordinate for a point which moves along the ray with velocity c . We multiply the first of these equations vectorally with \mathbf{k} and the other with \mathbf{r} , we find that

$$\frac{d}{dt}(\mathbf{r} \times \mathbf{k}) = 0.$$

This implies that

$$\mathbf{r} \times \mathbf{k} = \text{constant}$$

along the same ray. If the angle between the two vectors denotes i (see figure 3.4), we find that

$$p = \frac{r \sin i}{c} = \text{constant}$$

along the same ray. The quantity p is designated the wave parameter, and this parameter plays an important role in seismology.

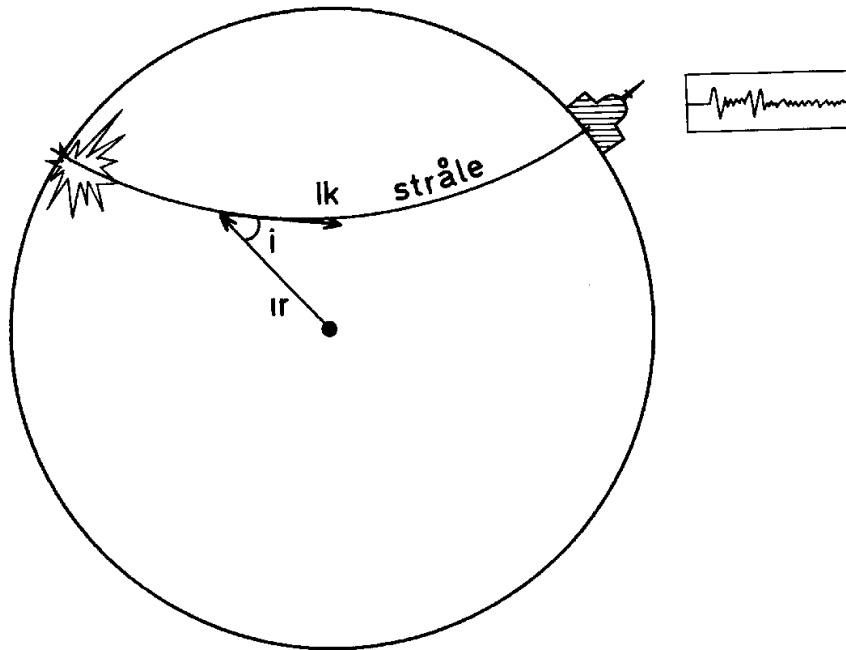

Figure 3.4: Seismic ray on a sphere.

3.4 Eikonal-equation and equations for amplitude variation along the rays

Previously we have assumed that there exists wave motion such that the wave number, wave amplitude, and angular velocity are slowly varying functions in

space and time. Under these requirements we have derived the fundamental results of wave kinematics and ray theory.

Wave motion of this type is possible in inhomogeneous or non-stationary media where the physical properties change little over a distance which corresponds to a wavelength or a time which corresponds to a wave period. One can therefore see that the requirements are fulfilled if the wavelength and period are sufficiently short.

As an example, we shall solve the wave equation (2.86) in the case that the propagation velocity, $c_0 = \sqrt{gH}$, is a function of x and y . We assume that the scale for inhomogeneity in the wave field is equal to the scale for inhomogeneity for the propagation velocity, c_0 . We assume that the solution of (2.86) can be written in the form

$$\eta = A(x, y, t)e^{i\chi(x, y, t)} \quad (3.13)$$

where the frequency and the wave vector are defined by

$$\omega = -\frac{\partial\chi}{\partial t}, \quad \mathbf{k} = \nabla\chi.$$

The presumption on slowly varying wave fields means that the relationship between the wavelength, $\lambda = 2\pi/k$, and the scale for inhomogeneity, L , must be a small number. Correspondingly the relationship between a wave period, $2\pi/\omega$, and the scale for non-stationary T must be a small number. We therefore introduce a ordering parameter such that

$$\epsilon = \frac{1}{kL} = \frac{1}{\omega T} \ll 1. \quad (3.14)$$

If we use the slowly varying scale for inhomogeneity and non-stationarity as references we can explicitly describe the rapid wave phase by the ordering parameter such that

$$\eta = A(x, y, t)e^{\epsilon^{-1}i\chi(x, y, t)}. \quad (3.15)$$

It will now be natural to assume that the amplitude, A , can be developed in a perturbation expansion with the help of the same ordering parameter

$$\eta = (A_0(x, y, t) + \epsilon A_1(x, y, t) + \epsilon^2 A_2(x, y, t) + \dots) e^{\epsilon^{-1}i\chi(x, y, t)}. \quad (3.16)$$

Taking the time derivative of the series expansion gives

$$\frac{\partial\eta}{\partial t} = \left(-i\epsilon^{-1}\omega A_0 - i\omega A_1 + \frac{\partial A_0}{\partial t} + O(\epsilon) \right) e^{\epsilon^{-1}i\chi(x, y, t)}.$$

The series expansion (3.16) shall now be substituted within (2.86). It can be realized that the complex exponential function is common for all terms and can be factored out. The expression which remains then must be fulfilled to all orders in ϵ . This gives a hierarchy of equations for the determination of χ , A_0 , etc.

The first of these equations is called *eikonal-equation*. In this case the equation is

$$\omega^2 = c_0^2 k^2 \quad (3.17)$$

where $k = |\mathbf{k}|$. We recognize this as the dispersion relation. If we can assume a stationary wave field we can write

$$\chi = S(x, y) - \omega t \quad (3.18)$$

and the phase line is determined by

$$S(x, y) - \omega t = \text{const.}$$

The wave vector

$$\mathbf{k} = \nabla \chi = \nabla S$$

is following normal to the phase line such that they scale.

The other equation is in the theory of electromagnetic waves often called the *transport equation* because it describes how the energy flux is conserved along a ray. In this case, the equation is

$$\omega \frac{\partial A_0}{\partial t} + \frac{\partial}{\partial t}(\omega A_0) + c_0^2 \mathbf{k} \cdot \nabla A_0 + \nabla \cdot (c_0^2 \mathbf{k} A_0) = 0. \quad (3.19)$$

If we multiply the equation with A_0 , and it is integrated one time we find

$$\frac{\partial}{\partial t}(\omega A_0^2) + \nabla \cdot (\mathbf{c}_g \omega A_0^2) = 0. \quad (3.20)$$

This is a conservation equation for density ωA_0^2 which is associated with group velocity $\mathbf{c}_g = c_0^2 \mathbf{k} / \omega$.

Equation (3.20) describes amplitude variation along the rays. Let us assume a stationary wave field and let us consider a domain (see figure 3.5) restricted to the rays a and b where the surfaces σ_A and σ_B are normal to the ray segments which lie between the rays. We assume that rays a and b lay so near to each other that c_0 , A_0 and ∇S can be set constant over the surfaces σ_A and σ_B . We integrate equation (3.20) over the area and use Gauss's theorem. Since the group velocity is parallel with the wave vector, the contribution to the integral disappears along the rays and we find

$$\sigma_A (c_0 A_0^2)_{\text{at A}} = \sigma_B (c_0 A_0^2)_{\text{at B}}. \quad (3.21)$$

A_0 represents the amplitude for the leading term in the series expansion (3.16), and the magnitude $c_0 A_0^2$ is therefore a measure of the energy flux. Equation (3.21) also expresses that in this case, the energy flux is constant along a ray. This is an important result, and this entails that there is no reflection of wave energy along the rays. This shows that the wave kinematics that we have developed

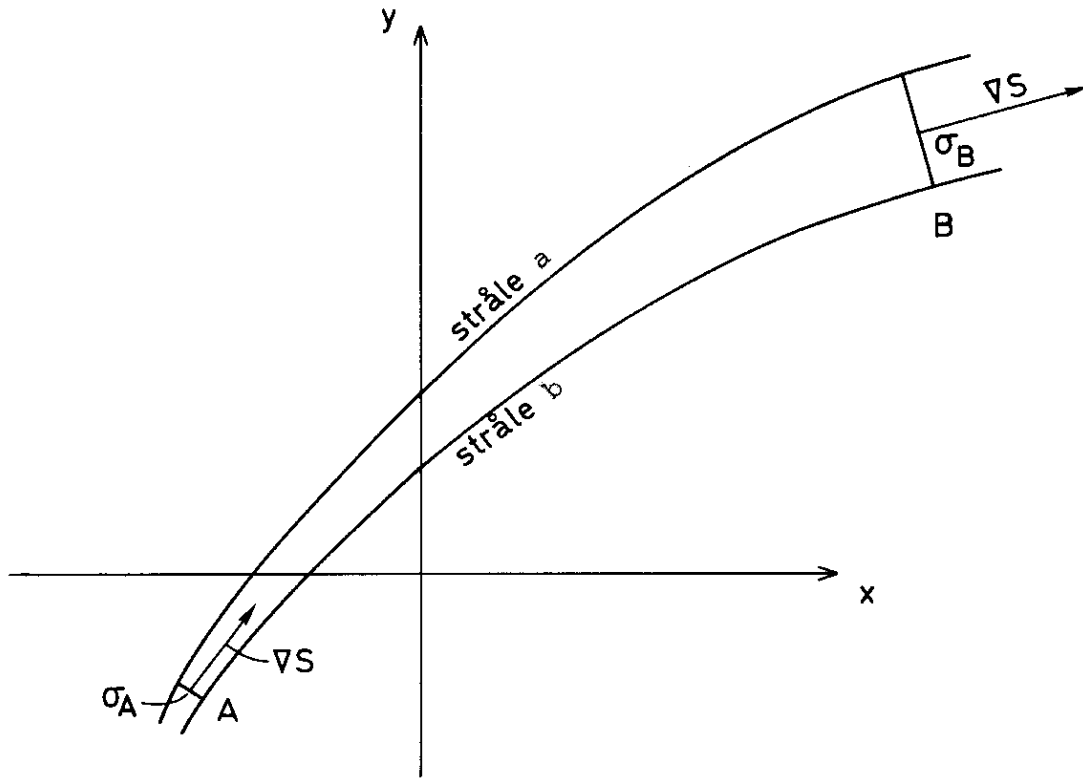

Figure 3.5: Sketch for the calculation of amplitude along a ray.

above requires that the changes in the medium are so gradual that the waves are refracted without any of the energy being reflected.

Notice that the application of Gauss's theorem was especially simple because the group velocity was parallel with the wave vector in this case, and thereby the contribution vanishes when integrating along the rays. In the case where the group velocity is not parallel with the wave vector, the contribution along the rays would be integrated. In such cases, it can be simpler to use wave paths instead of rays like those sketched in figure 3.5.

To end, we shall, by example demonstrate an application of the results from this section. We consider that along the surface waves which propagate in towards a coast where the coast line and bottom topography are sketched in figure 3.6. For a wave which has a straight phase line out in deep water, the rays are indicated in the figure. We choose a ray section $A - B$ outside of the headland and the ray section $A' - B'$ outside of the inlet such that the surface sections by A and A' are equally large. We furthermore assume that the wave amplitude is equally big for A and A' . Since the surface sections for the wave segments are smaller at B than at B' , it follows from (3.21) that the wave amplitude is larger at B than at B' . That the wave energy is focused towards the headland and spreads in the bay can be often observed in nature. This can be best seen from the air, and the

aerial photograph in figure 3.7 shows many such effects.

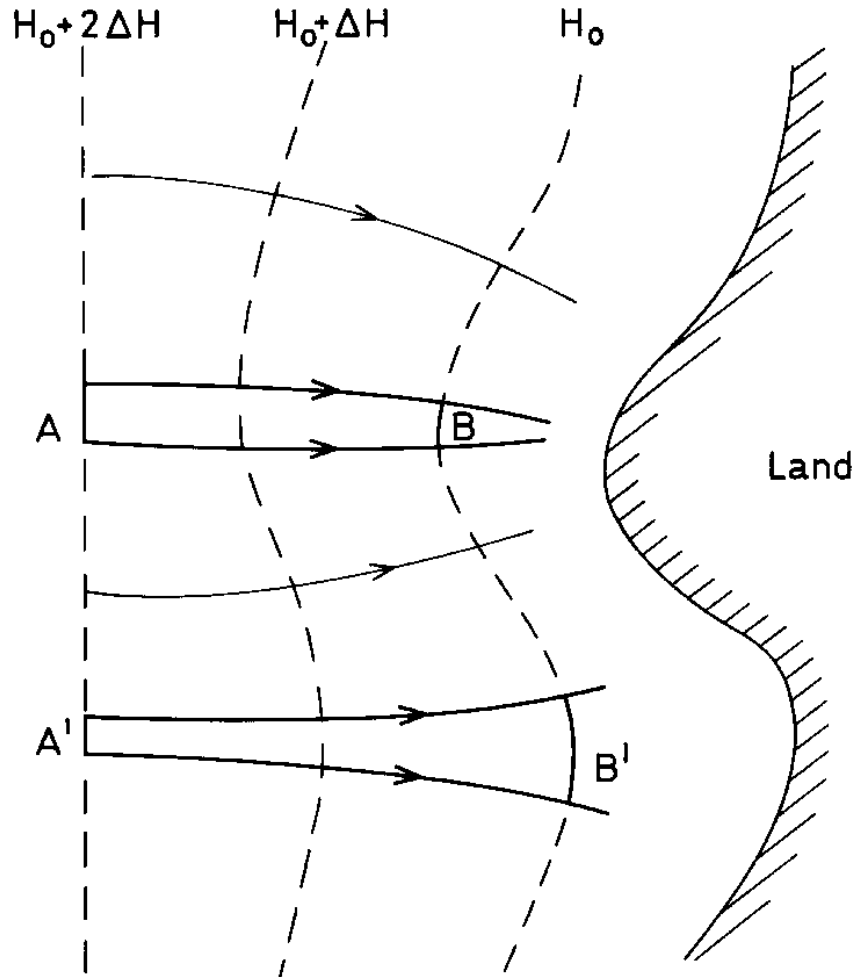

Figure 3.6: Sketch for waves approaching coast.

3.5 Amplitude variation in nearly periodic wave trains

In the previous section, we integrated (3.20) with the help of Gauss's law for waves with fixed frequency (monochromatic waves). For nearly periodic wave trains that arise from dispersion, the amplitude variation cannot be found by a simple application of Gauss's law, but rather equation (3.20) must be integrated in both space and time.



Figure 3.7: Aerial photograph from an area near Kiberg on the coast of Finnmark. The photo was taken 12. June 1976 by Fjellanger Widerøe A.S.

We know that for linear waves, the average energy flux, \mathbf{F} , is given by the average energy density, E , and the group velocity \mathbf{c}_g

$$\mathbf{F} = \mathbf{c}_g E.$$

Indeed, we have only seen this for a single wave component, but it is reasonable to assume that the same relation is valid, with a good approximation in the case of slowly varying wave trains. If there is not any energy input to the waves by outside influences such as wind or the interaction between the waves and the current, then the net energy flux into the domain correspond to the change in energy density within the same domain. For plane waves which propagate in the x -direction, this can be expressed by

$$\frac{\partial E}{\partial t} + \nabla \cdot (\mathbf{c}_g E) = 0. \quad (3.22)$$

If the average energy density is independent of time, which is valid for monochromatic waves with fixed frequency, (3.22) can be integrated with the help of Gauss's law, which we have seen earlier.

The energy equation (3.22) plays an important role in wave theory. A generalized equation containing the source term and coupling term which respectively express the generation of waves caused by wind and the interaction between waves and currents, is often used for wave forecasting (Kinsman 1965).

Now the energy density is proportional to a^2 where a is the wave amplitude, and for plane gravity waves in deep water we have $E = \frac{1}{2}\rho g a^2$. From equation (3.22) we thus find

$$\frac{\partial a^2}{\partial t} + \nabla \cdot (\mathbf{c}_g a^2) = 0. \quad (3.23)$$

We will not go further towards general solutions of the energy equation (3.22), but instead it will be illustrated by studying two simple solutions.

For long surface waves which propagate over a smooth flat bottom with slope α , the group velocity is $c_g = \sqrt{gH} = \sqrt{g\alpha x}$ (see section 2.7). If the wave train is periodic in time such that $\frac{\partial a^2}{\partial t} = 0$, it follows from (3.23) that the energy flux is constant and we therefore must have that the wave amplitude is

$$a = \text{const.} \cdot x^{-\frac{1}{4}}.$$

This is in agreement with what we have found in section 2.10.

For waves generated by a constant disturbance at $t = 0$ and $x = 0$, the group velocity will be given by

$$c_g = \frac{x}{t}$$

where t is the transit time from a point at x . The wave amplitude can be found from (3.23)

$$a = \text{const.} \cdot x^{-\frac{3}{2}} t$$

By comparisons with expression (2.72), the constant can be determined.

Exercises

1. We assume that the phase speed for seismic waves is a function of depth z , which can be written as $c(z)$. The velocity at the surface $z = 0$ is c_0 . Find the path for a wave with angular velocity ω_0 which goes out from a point O at the surface in a direction defined by an angle θ with the surface. We assume that the waves propagate towards a finite area such that the surface can be considered to be a plane. Find the distance from O to the point A where the rays come up to the surface. $c(z)$ is a monotonously increasing function of z . Determine the transit time as a function of the distance OA , and find the deepest point of the rays.

Figure 3.8: The figure is so far missing!

2. In a sea with uniform depth H_0 , there are shoals with a depth given by

$$H = H_0(1 - \alpha e^{-\frac{x^2+y^2}{L^2}})$$

where α and L are constants. Find the rays for plane waves with wavelength $\lambda = \beta L$ (where β is a constant) which come in towards the shoals along the x -direction.

3. **Self-focusing wave generator**

In one end of a wave channel, a wave is generated with frequency $f(t)$. The frequency is 10 Hz when the wave generator is turned on, and it is turned off 100 seconds later. We wish to concentrate as much wave energy as possible at a prescribed point in the wave channel. Use ray theory to find the optimal form of $f(t)$. Find the point where the energy concentrates and the time when this happens. Assume that the channel is long enough that there is no reflection from the opposite end and that it is much deeper than it is wide.

Does ray theory work well here? What method would work best if the water depth is much smaller than the length of the waves that are generated?

4. Waves over a parabolic bottom

A bottom topography (bathymetry) is given by $h(x) = h_0(\frac{x}{l})^2$. We assume that linear, hydrostatic shallow water theory is valid and that the waves are monochromatic in time (only one frequency).

- (a) Use ray theory to determine the phase function χ .
- (b) Give an interpretation of the expression $\frac{1}{c} \frac{\partial c}{\partial x} \lambda$. Which requirement must we impose on $\frac{\omega l}{\sqrt{gh_0}}$ for ray theory to be valid?
- (c) Find a solution of the shallow water equation of the form $\eta = e^{i\omega t} x^q$. Compare this with the results we found with the help of ray theory.

5. Slowly varying wave sources

We consider plane, nearly periodic waves in a homogeneous medium. We assume linear conditions, and the waves propagate in the positive x -direction. The dispersion relation is given by $\omega = \frac{1}{3}k^3$. At $t = 0$ the local wave length is given by $\lambda = a(2 + \tanh(bx))$.

- (a) We shall use ray theory, which conditions must then be imposed on the parameters a and b ?
- (b) Use ray theory and the method of characteristics to estimate the local wave length for all x at a later time. A difficult algebraic equation will pop up here, and this should not be solved.

6. Waves with slanted incidence

The given depth is independent of the y -direction, i.e. depth $h = h(x)$. We shall study how long harmonic waves behave over this bottom. The waves shall have a slanted incidence, which means that the wave number has a component in the y -direction.

- a Find the amplitude varies according to physical optics (the transport equation). Is it correct that a wave will always be amplified when it comes into shallower water?
- b Discuss what happens with the amplitude when the wave propagates into deeper water.

7. Waves from an initial disturbance 2.

We consider again the Klein-Gordon equation given in the exercise in the previous chapter. At $t = 0$, assume a point disturbance at $x = 0$. Use ray theory to determine the phase function at large x and x . Compare with the answer of the exercise in the previous chapter.

Chapter 4

Trapped waves

The motion of gravity waves decay quite fast downwards. For a depth that is comparable with a wavelength or more the motion is neglectible. The wave energy is then connected to a zone close to the surface and the energy is bound to this area while the waves are propagating forward. The wave is then trapped to the surface and the surface is then a wave-guide. Trapped waves and wave-guides play an important role in wave motion. In the ocean and in the atmosphere the density layers can contain horizontal layers with low sound speed. Furthermore, this layer will then act as a wave-guide and sound with special frequencies will be able to propagate over long distances with small attenuation.

4.1 Gravity waves trapped by bottom topography

Waves will be refracted when they propagate on changing water depth. This is caused by the difference in speed for long gravity waves on deep water compared to shallow water. At a straight coastline where the water depth is linearly increasing outwards, waves that propagates towards the coast will be refracted this line. If the waves are reflected at the shore, the waves will be refracted on it's way out and the refraction will be so great that they will turn and propagate towards the coast again. After a new reflection this phenomena will of course happen again, and if this is periodic the waves are trapped. A sketch of the wave rays are shown in figure 4.1.

There is a simple solution of Laplace equation (2.11) with boundary conditions (2.12) (with $\sigma = 0$) that describes trapped gravity waves along a coastline where the depth increase linearly with the distance from the coast. The bottom topography and the choice of coordinate system is shown in figure 4.2.

Together with the boundary conditions (2.12) at the free surface there is also

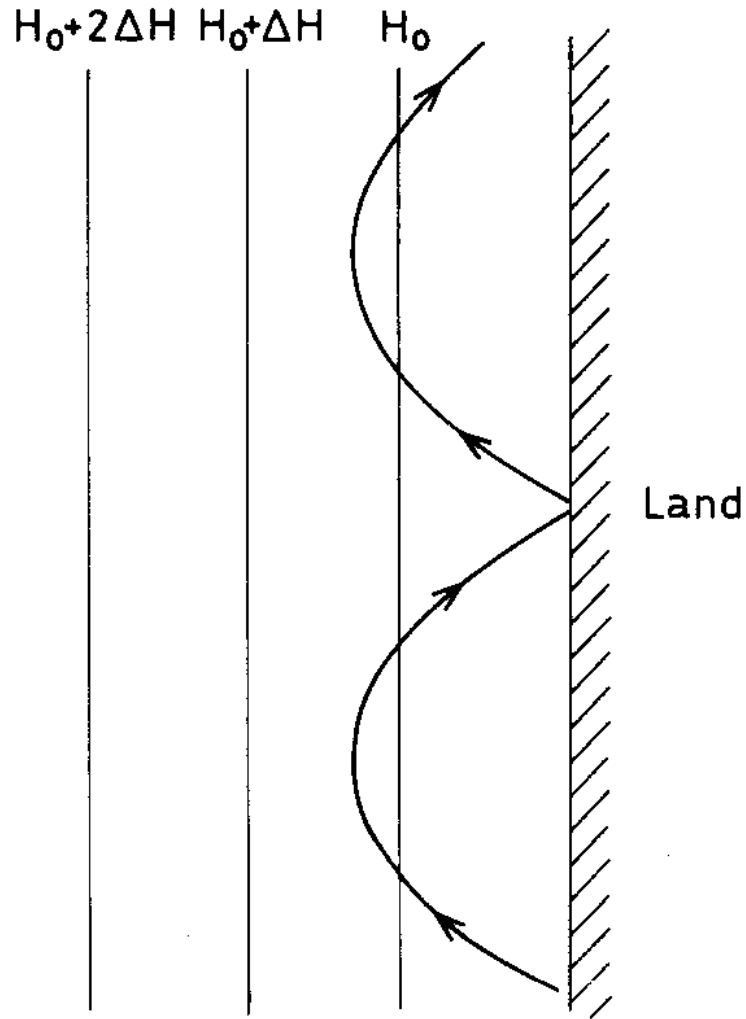

Figure 4.1: Rays for trapped waves.

the kinematic condition

$$\frac{\partial \phi}{\partial x} \tan \theta + \frac{\partial \phi}{\partial z} = 0$$

at the sea floor $z = -x \tan \theta$. Velocity potential is

$$\phi = -\frac{ag}{kc} e^{-k(x \cos \theta - z \sin \theta)} \cos k(y - ct) \quad (4.1)$$

and

$$c = \pm \left(\frac{g}{k} \sin \theta \right)^{\frac{1}{2}}.$$

The corresponding elevation is

$$\eta = ae^{-kx \cos \theta} \sin k(y - ct).$$

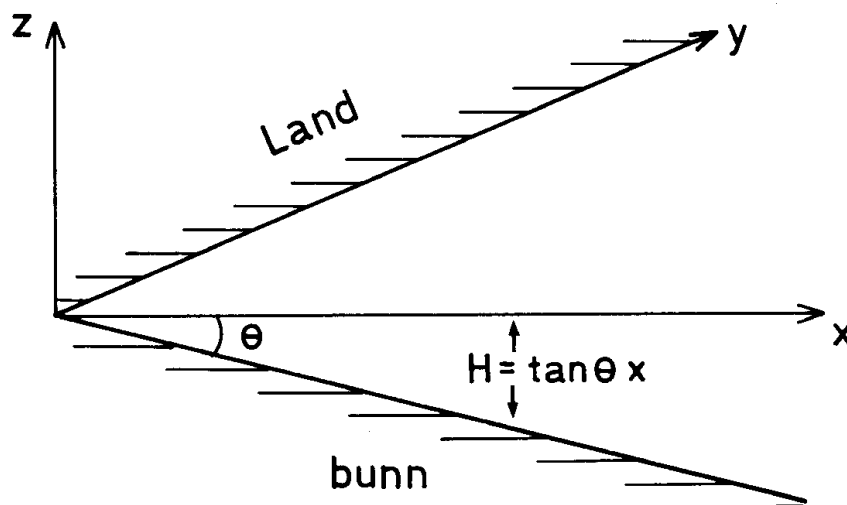

Figure 4.2: Geometry of the coast.

We see that the waves propagate along the coast with a speed that is dependent of the inclination of the sea floor and that the amplitude decays exponential from the coast. The wave will be able to propagate both directions since the phase speed can have the value \pm . The coast and the bottom topography creates here a two-way wave guide. This type of waves can be observed for example in a channel with steep inclination. The waves are called edge-waves and the solution (4.1) represent the first mode in several solutions (Ursell 1952). Corresponding simple solutions is not known.

Når vi skal studere fenomenet mer inngående, skal vi forutsette at bølgene er så lange at vi kan benytte gruntvannstilmærmelsen. Vi legger koordinataksene som på figur 4.1, og lar vanndypet H være en monotont økende funksjon av x . Ved land tenker vi oss at det er en vertikal vegg og at vanndypet er vesentlig større enn bølgeamplituden. Overflatehevningen η skriver vi på formen

$$\eta = \hat{\eta}(x) \sin k(y - ct)$$

hvor $\hat{\eta}(x)$ er en funksjon av x som skal bestemmes. Fra (2.86) får vi så

$$\frac{d}{dx} \left(H \frac{d\hat{\eta}}{dx} \right) = k^2 \left(H - \frac{c^2}{g} \right) \hat{\eta}. \quad (4.2)$$

Ved kystlinjen $x = 0$ er volumfluksen i x -retning null, og dette innebærer

$$\frac{d\hat{\eta}}{dx} = 0 \quad \text{for} \quad x = 0. \quad (4.3)$$

For fangede bølger må dessuten

$$\hat{\eta} \rightarrow 0 \quad \text{når} \quad x \rightarrow \infty. \quad (4.4)$$

Likningen (4.2) med randbetingelse (4.3) og (4.4) er et egenverdiproblem av kjent type som for valgte k gir bestemte tillatte verdier av c .

Vi innfører

$$\hat{\eta} = H^{-\frac{1}{2}}\psi$$

og substituerer i (4.2). Dette gir

$$\frac{d^2\psi}{dx^2} = -k^2(W(x) - 1)\psi \quad (4.5)$$

hvor

$$W(x) = \frac{c^2}{gH} + \frac{1}{4} \frac{H'^2 - 2HH''}{(kH)^2}.$$

Her betyr ' derivasjon med hensyn på x . Grenseflatebetingelse for ψ blir

$$\begin{aligned} \frac{d\psi}{dx} &= \frac{1}{2} \frac{\psi}{H} \frac{dH}{dx} & \text{for } x = 0 \\ \psi &\rightarrow 0 & \text{for } x \rightarrow \infty. \end{aligned} \quad (4.6)$$

Dette viser at egenverdiproblemet er av tilsvarende type som det som fremkommer ved løsning av Schrödinger-likningen i kvantemekanikk. Dersom H er en langsomt varierende funksjon av x , så kan W tilnærmet settes

$$W = \frac{c^2}{gH}. \quad (4.7)$$

Siden faktoren $1/(kH)^2$ inngår i leddet som sløyfes, venter vi at tilnærmelsen blir bedre dess kortere bølgelengden er. I samsvar med denne tilnærmelsen modifiseres den første av grenseflatebetingelsene (4.6) til

$$\frac{d\psi}{dx} = 0 \quad \text{for } x = 0. \quad (4.8)$$

Løsningen av (4.5) skifter karakter i henhold til om $W > 1$ eller $W < 1$. For $W > 1$ (dvs. $H < \frac{c^2}{g}$) kan ψ ha karakter av svingninger, mens for $W < 1$ (dvs. $H > \frac{c^2}{g}$) kan løsningen være eksponensielt dempet.

Vi betrakter nå tilfellet hvor H er en monotont økende funksjon av x , og H går mot en konstant verdi for $x \rightarrow \infty$ slik at $W > 1$ for $0 < x < x_0$, og $W < 1$ for $x > x_0$. For visse verdier av k og c kan vi derfor ha løsninger for ψ som har karakter av fangede bølger hvor bevegelsen er eksponensielt dempet for $x > x_0$. Avhengig av antallet knutepunkter for svingningene i området $x < x_0$ vil man kunne ha forskjellige moder for bølgebevegelsen. I figur 4.3 er $\psi(x)$ skissert for 1. og 2. mode.

Fenomenet med fangede bølger i havet er særlig viktig for lange bølger. Årsaken til det er at de lange bølgene med bølgelengde 100 km og mer, vil være mer eller mindre upåvirket av små ujevnheter i bunn og kystlinje og mer styrt av de storstilte endringene i bunnforholdene. Derfor kommer de enkle modellene vi har behandlet her ofte til anvendelse.

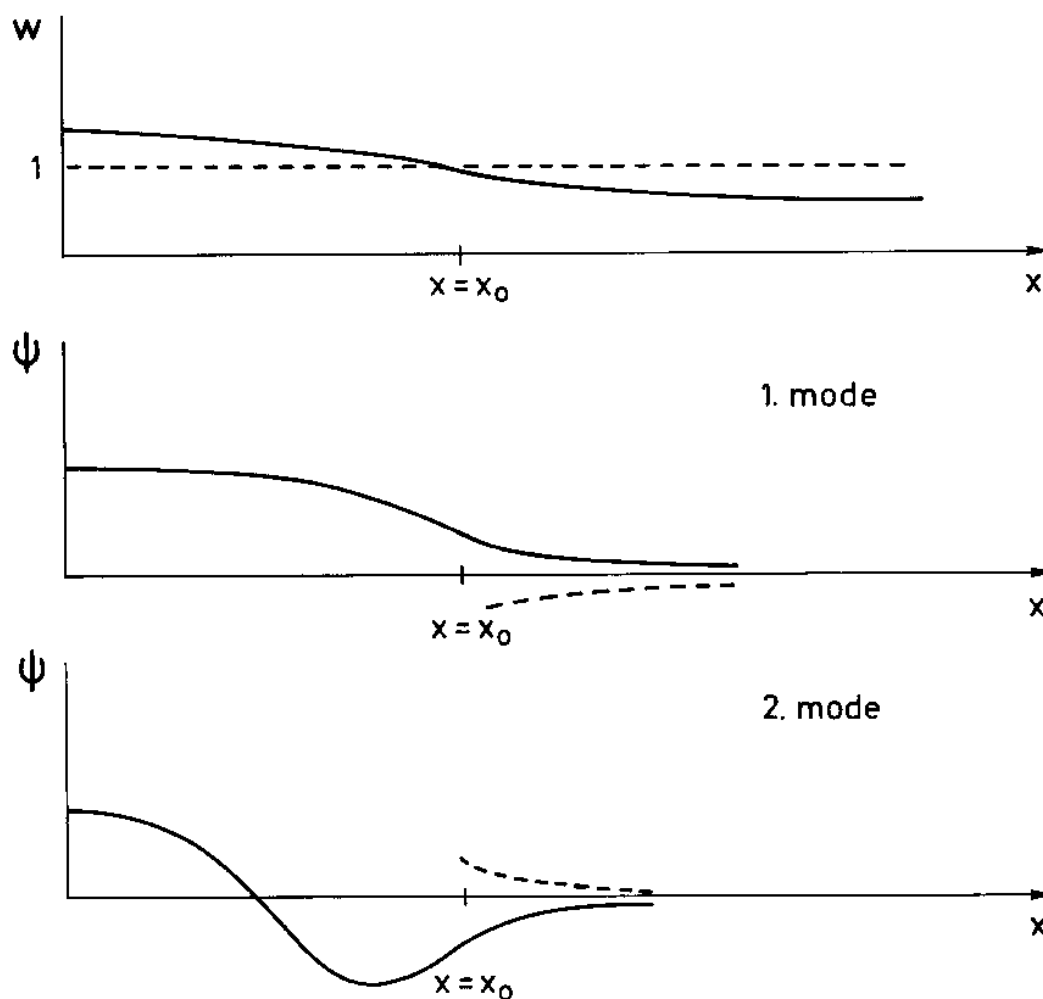

Figure 4.3: De to laveste fangede modene.

4.2 WKB-metoden

Uten å måtte ty til numeriske metoder kan det være vanskelig å bestemme løsningene av (4.5) som tilfredsstiller grenseflatebetingelsene. Vi skal her vise en metode til å finne en tilnærmet løsning. Vi setter

$$f(x) = W(x) - 1$$

hvor W er gitt ved (4.7). Likningen (4.5) kan derved skrives

$$\frac{d^2\psi}{dx^2} = -k^2 f(x)\psi. \quad (4.9)$$

For enkelthets skyld forutsetter vi som før at H er en monotont økende funksjon av x og at H går mot en konstant verdi for $x \rightarrow \infty$. For store verdier av k kan

vi finne en tilnærmet løsning av (4.9) ved å benytte samme metode som i punkt (3.4). Vi skriver følgelig ψ ved en rekkeutvikling

$$\psi = e^{ikS} \left[P_0(x) + \frac{P_1(x)}{ik} + \dots \right]$$

hvor S , P_0 og P_1 er funksjoner av x . Rekkeutviklingen settes inn i (4.9), og koeffisienten foran hvert ledd i den rekken som fremkommer kreves lik null. Derved får man

$$\left(\frac{dS}{dx} \right)^2 = f(x),$$

$$\frac{d}{dx} \left(P_0^2 \frac{dS}{dx} \right) = 0.$$

Dette leder til

$$S = \pm \int f D^{\frac{1}{2}} dx$$

og

$$P_0 = \text{konst.} / f^{\frac{1}{4}}.$$

Tar man hensyn bare til det ledende leddet i rekkeutviklingen kan ψ derfor skrives

$$\psi = A f^{-\frac{1}{4}} \sin \left(k \int f^{\frac{1}{2}} dx \right) + B f^{-\frac{1}{4}} \cos \left(k \int f^{\frac{1}{2}} dx \right). \quad (4.10)$$

hvor A og B er konstanter. Løsningen (4.10) er kjent som WKB-løsningen, hvor navnet er formet ved initialene til Wentzel, Kramers og Brillouin som fant løsningen uavhengig av hverandre omkring 1926. Det er åpenbart at (4.10) ikke er gyldig i nærheten av og i punktet $x = x_0$ hvor $f = 0$. En løsning av (4.9) som er gyldig i dette området finner vi ved å gå frem på følgende måte. Vi skriver

$$f(x) \simeq -|f'(x_0)|(x - x_0) \quad (4.11)$$

hvor $f'(x_0)$ betegner den deriverte av f i punktet $x \simeq x_0$, og vi innfører ξ som ny variabel slik at

$$x - x_0 = k^{-\frac{2}{3}} |f'(x_0)|^{-\frac{1}{3}} \xi.$$

Likningen (4.9) kan derved skrives på formen

$$\frac{d^2 \psi}{d\xi^2} = \xi \psi. \quad (4.12)$$

Dette er Airy's differensiallikning som ved en spesiell transformasjon kan bringes over til Bessels likning. Airy's likning har to lineært uavhengige løsninger $\text{Ai}(\xi)$ og $\text{Bi}(\xi)$ som betegnes Airys funksjoner. Den ene funksjonen, $\text{Ai}(\xi)$, har karakter av svingninger for $\xi < 0$, mens for $\xi > 0$ er funksjonen eksponensielt dempet slik at $\text{Ai}(\xi) \rightarrow 0$ for $\xi \rightarrow \infty$. (Se Abramowitz og Stegun 1972). Vi legger merke til at siden k er forutsatt å være stor, så vil $|\xi|$ kunne være stor selv om $|x - x_0|$ er

så liten at rekkeutviklingen (4.11) er gyldig. Siden vi forutsetter at $\psi \rightarrow 0$ for $x \rightarrow \infty$, må vi som løsning av (4.12) velge

$$\psi = D\text{Ai}(\xi) \quad (4.13)$$

hvor D er en konstant. For store verdier av ξ gjelder følgende assymptotiske uttrykk for $\text{Ai}(\xi)$

$$\text{Ai}(\xi) \simeq \frac{1}{2\sqrt{\pi}} \xi^{-\frac{1}{4}} e^{-\frac{2}{3}\xi^{\frac{3}{2}}} \quad \text{for} \quad \xi > 0$$

og

$$\text{Ai}(\xi) \simeq \frac{1}{\sqrt{\pi}} |\xi|^{-\frac{1}{4}} \sin\left(\frac{2}{3}|\xi|^{\frac{3}{2}} + \frac{\pi}{4}\right) \quad \text{for} \quad \xi < 0.$$

Skal uttrykkene (4.10) og (4.13) for ψ falle sammen for store verdier av $|\xi|$, medfører dette at $A = B$ og at $k \int f^{\frac{1}{2}} dx = \frac{2}{3}|\xi|^{\frac{3}{2}}$. Dette fører til at WKB-løsningen for $x < x_0$ kan skrives

$$\psi = A f^{-\frac{1}{4}} \sin\left(k \int_x^{x_0} f^{\frac{1}{2}} dx + \frac{\pi}{4}\right) \quad (4.14)$$

hvor A er en vilkårlig konstant.

Siden f er forutsatt å være en langsomt varierende funksjon av x , så er

$$\frac{d\psi}{dx} = -A k f^{\frac{1}{4}} \cos\left(k \int_x^{x_0} f^{\frac{1}{2}} dx + \frac{\pi}{4}\right)$$

i den tilnærming vi her regner. Grenseflatebetingelsen ved $x = 0$ gitt ved (4.8) medfører at

$$k \int_x^{x_0} f^{\frac{1}{2}} dx + \frac{\pi}{4} = (2n + 1) \frac{\pi}{2} \quad (4.15)$$

hvor $n = 0, 1, 2$. Likningene (4.15) bestemmer egenverdiene for k eller c . Det viser seg at WKB-metoden ofte gir egenverdiene med god tilnærming selv for moderate eller endog små verdier av k . En er fristet til å nevne et sitat fra en kjent anvendt matematiker: En god formel kjennetegnes ved at den kan brukes langt utenfor sitt gyldighetsområde.

4.3 Waves trapped by rotational effects. Kelvin waves

The Coriolis force is not neglectible for very long gravity waves and this force will modify the wave motion. These waves are called gravity-inertia waves and have other properties than ordinary gravity waves. In this section we will study how the Coriolis force is able to trap waves even if they propagate on constant

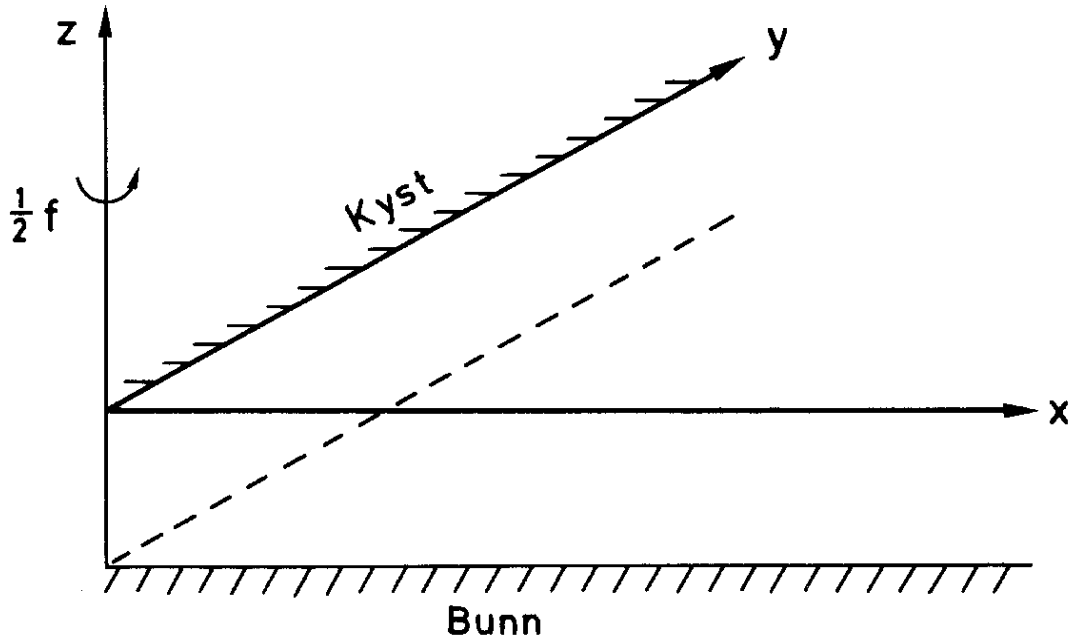

Figure 4.4: Kystgeometri.

depth. We will investigate the wave motion in a fluid layer limited by a horizontal $z = -H$ and a straight coastline $x = 0$. (See figure 4.4).

The fluid layer rotate with a constant angular velocity $\frac{1}{2}f$ around the vertical axis. For long waves, with hydrostatic pressure, the wave motion is described by the equation similar to (2.84) and (2.85). However, the Coriolis force is included in the eq. of motion together with the pressure force. If the elevation and volume flux in x - and y -direction still are denoted η , U and V , then we get the following equations:

$$\begin{aligned}\frac{\partial \eta}{\partial t} &= -\frac{\partial U}{\partial x} - \frac{\partial V}{\partial y} \\ \frac{\partial U}{\partial t} - fV &= -c_0^2 \frac{\partial \eta}{\partial x} \\ \frac{\partial V}{\partial t} + fU &= -c_0^2 \frac{\partial \eta}{\partial y}\end{aligned}$$

These equation has a solution on the form

$$\begin{aligned}\eta &= ae^{-\frac{f}{c_0}x} \sin k(y + c_0t) \\ U &= 0 \\ V &= -c_0ae^{-\frac{f}{c_0}x} \sin k(y + c_0t)\end{aligned}$$

This is a wave with amplitude a and wave number k that propagates in negative y -direction. The motion decay exponentially from the coast. Waves of this type is named *Kelvin waves*. Note that with a choice of direction of rotation that is done here, (see figure 4.4), the Kelvin waves only propagate such that the coast is to the right compared to the direction of propagation. Furthermore, the coast is a one-way wave guide for the Kelvin waves.

The tidal waves close to the coast is usually Kelvin waves, but in this case the wave motion is often modified by the shape of the coast and bottom topography. The simple model we have studied has only the purpose to illustrate the physical principles of this wave motion. The trapped waves discussed in the two last sections has many applications; e.g. tidal motion, flood waves and Tsunamis caused by earthquake. For further reading see Mysak and Le Blond (1978) and Gill (1982). Kelvin and edge waves and their importance for flooding and tide along the Norwegian coast are discussed in Martinsen, Gjevik and Røed (1979).

Chapter 5

WAVES ON CURRENTS. DOWNSTREAM AND UPSTREAM WAVES. SHIPWAKES. WAVE RESISTANCE.

In applications one often encounters the situation that the wave motion occurs at the same time as there is a current in the liquid. The wave motion can in such cases be modified by the current, and current can give rise to special wave phenomena.

A stationary current past some kind of obstacle, for example a rock on the bottom of a river, can give rise to stationary wave patterns on the downstream or upstream side of the obstacle. These stationary wave patterns are called downstream waves or upstream waves. Similar wave phenomena can occur when a disturbance, for example a ship or an insect, is moving with constant velocity along the liquid surface. In the following we shall treat down- and upstream waves in the case that the current is uniform and stationary. In that case there is a direct analogy between the wave pattern generated by a fixed obstacle in the current and the waves generated by a disturbance that moves with constant velocity along the water surface.

In those cases where the current is not stationary or uniform, the current alone can modify the wave motion. Waves that propagate into a region with horizontal shear currents can for example have their wave length and amplitude modified due to the effects of the current. This phenomenon can often be observed for example near river estuaries. Similarly, vertical shear currents can modify wave motion, and the effect will depend on the wave length. Wave motion that is affected by non-uniform currents is difficult to treat mathematically, and we shall in the following suffice by studying a simple example. The effect of currents on waves

motion is currently a field of active research. Peregrine (1976) has in a review article given a good introduction to mathematical methods and problems within this field.

5.1 Downstream and upstream waves

For simplicity we start by considering two-dimensional wave motion generated by some disturbance that moves along the surface with constant speed U . Similar wave patterns will arise if the liquid moved with uniform and stationary speed U past a fixed obstacle.

The dispersive properties of gravity–capillary waves on deep water can be summarized in the following diagram (figure 5.1) where c_m is the smallest phase velocity that can occur and λ_m the corresponding wave length (see section 2.2). If $U > c_m$ then we have two wave components with wave lengths λ_k and λ_t , respectively, and phase velocity $c = U$. These wave components can therefore compose a stationary wave pattern in front of or behind the disturbance. We know that for wave lengths greater than λ_m the group velocity is less than the phase velocity ($c_g < c$), but the opposite ($c_g > c$) is the case for wave lengths shorter than λ_m . We also know that the energy of the waves propagates with

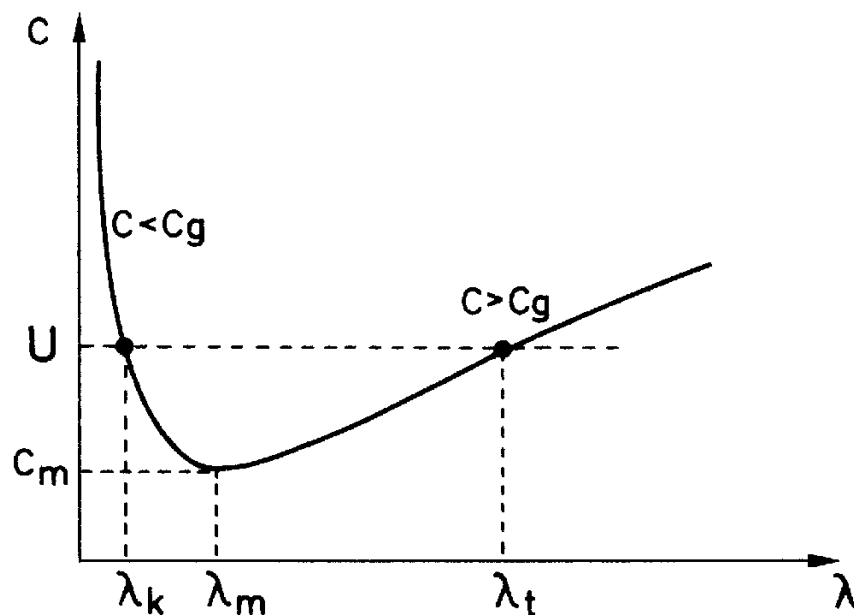

Figure 5.1: Dispersive properties for gravity–capillary waves.

the group velocity. The wave energy for waves with length $\lambda_t > \lambda_m$ will therefore not keep up with the disturbance, while wave energy for waves with length $\lambda_k < \lambda_m$ will run away from the disturbance. We will therefore get two stationary

wave trains as shown in figure 5.2, gravity waves with waven length λ_t behind the disturbance (downstream waves), and capillary waves with wave length λ_k in front of the disturbance (upstream waves). If $U < c_m$ then no waves can follow the disturbance, and in this case we will not have either downstream or upstream waves associated with the disturbance. Similarly, downstream waves will not exist if U exceeds the velocity \sqrt{gH} where H is the water depth. The amplitudes for downstream and upstream waves will depend on the disturbance. Even though both types of waves may be possible, it may occur that some disturbance only provokes one type with appreciable amplitude while the other type has insignificant amplitude.

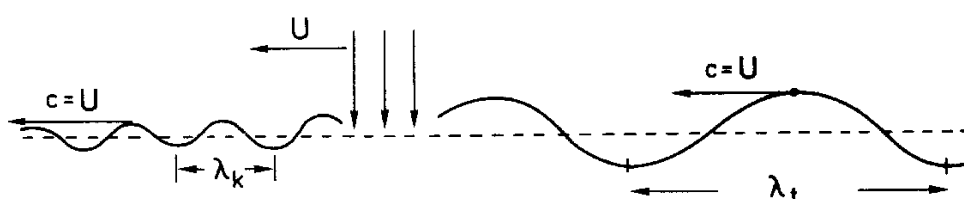

Figure 5.2: Downstream and upstream waves.

5.2 The amplitude for two-dimensional downstream waves

Når man skal beregne amplituden for le- eller lo-bølger, vil man kunne komme opp i matematiske vanskeligheter om man direkte søker den stasjonære bevegelsen. Likningene for den stasjonære bølgebevegelsen vil i alminnelighet lede til en flertydighet, slik at det ikke umiddelbart fremgår av regningene hvilke bølger som skal ligge på le- eller lo-siden av forstyrrelsen. Lar man bølgebevegelsen fremkomme ved at forstyrrelsen utvikler seg gradvis frem mot en stasjonær tilstand, vil man kunne unngå denne vanskeligheten. Her skal vi for enkelthets skyld gjennomføre regningene når forstyrrelsen utvikler seg på en spesiell måte (Whitham 1974). Vi betrakter en trykkforstyrrelse

$$p_0(x, t) = f(x)e^{\varepsilon t} \quad \varepsilon > 0 \quad (5.1)$$

på overflaten av et væskelag med tykkelse H , som strømmer med uniform og stasjonær hastighet U i x -aksens retning over en plan horisontal bunn $z = -H$, se figur 5.3.

Vi tenker oss at trykkforstyrrelsen er konsentrert omkring $x = 0$ slik at $p_0 \rightarrow 0$ for $x \rightarrow \pm\infty$, og at trykket har utviklet seg fra null ved $t = -\infty$ henimot en verdi av p_0 ved $t = 0$. Etter en viss tid $t > 0$ er det klart at vi vil få et urealistisk høyt

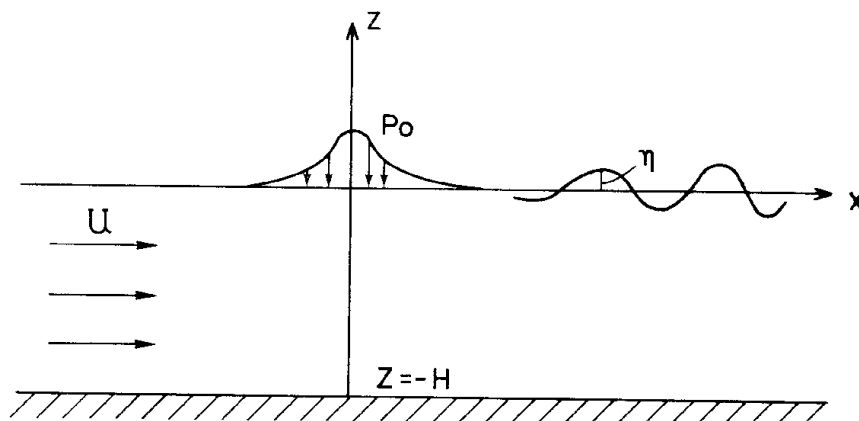

Figure 5.3: Le-bølger.

trykk slik at de lineariseringer vi skal gjøre vil bli ugyldige. For tilstrekkelig små verdier av p_0 vil imidlertid løsningen være gyldig i et begrenset tidsrom $t = O(\frac{1}{\varepsilon})$ etter tidspunktet $t = 0$. Ved å la $\varepsilon \rightarrow 0$, vil vi så kunne finne den stasjonære bølgebevegelsen som settes opp av trykkforstyrrelsen p_0 .

Vi antar at væsken er friksjonsfri, homogen og inkompressibel og at bevegelsen som settes opp av trykkforstyrrelsen er virvelfri. Vi skal videre neglisjere overflate-spenningen slik at vi begrenser oss til å betrakte le-bølger. Hastighetspotensialet ϕ for bevegelsen tilfredsstiller Laplace likningen

$$\nabla^2 \phi = 0.$$

De lineariserte grenseflatebetingelser ved overflaten kan skrives

$$\begin{aligned} \frac{\partial \eta}{\partial t} + U \frac{\partial \eta}{\partial x} &= \frac{\partial \Phi}{\partial z} \\ \frac{\partial \Phi}{\partial t} + U \frac{\partial \Phi}{\partial x} + g\eta &= -\frac{p_0}{\rho} \end{aligned} \quad (5.2)$$

for $z = 0$. Vi har her på vanlig måte redefinert potensialet slik at konstanten $\frac{\rho}{2}U^2$ i Eulers trykklikning trekkes inn i potensialet sammen med funksjonen $f(t)$ (se avsnitt 2.1). Videre er grenseflatebetingelsene ved bunnen $z = -H$

$$\frac{\partial \Phi}{\partial z} = 0.$$

Vi søker en løsning av disse likningene av formen

$$\begin{aligned} \Phi(x, z, t) &= \phi(x, z)e^{\varepsilon t} \\ \eta(x, z) &= \eta_0(x)e^{\varepsilon t} \end{aligned} \quad (5.3)$$

Setter man disse uttrykkene inn i Laplace-likningen og grenseflatebetingelsene (5.2), kan faktoren $e^{\varepsilon t}$ forkortes, og man står igjen med et sett av likninger for ϕ og η_0 . Vi forutsetter at den Fourier transformerte i x for funksjonene $f(x)$, $\phi(x, z)$ og $\eta_0(x)$ eksisterer, og vi betegner disse ved \tilde{f} , $\tilde{\phi}$ og $\tilde{\eta}_0$ (se avsnitt 2.7). På tilsvarende måte kan vi så finne likninger for ϕ og η_0 , og løsningen av disse gir at

$$\tilde{\eta}_0 = \frac{\tilde{f} k \tanh kH}{\rho[(kU - i\varepsilon)^2 - gk \tanh kH]}.$$

Ved å benytte inversjonsteoremet (2.57) finner vi at overflate deformasjonen på grunn av trykkforstyrrelsen kan skrives

$$\eta(x, t) = \frac{e^{\varepsilon t}}{2\pi\rho} \int_{-\infty}^{\infty} \frac{\tilde{f} k \tanh kH e^{ikx}}{(kU - i\varepsilon)^2 - gk \tanh kH} dk. \quad (5.4)$$

Vi skal beregne integralet (5.4) i det spesielle tilfellet at vanddyppet er uendelig stort, og vi har at

$$k \tanh kH \rightarrow |k|$$

for $H \rightarrow \infty$. Vi skal dessuten for enkelthets skyld velge en trykkforstyrrelse slik at

$$f(x) = Q\delta(x)$$

hvor $\delta(x)$ er delta-funksjonen som tidligere er blitt behandlet i avsnitt 2.7, og Q er konstant. Dette medfører at

$$\tilde{f}(k) = Q$$

slik at \tilde{f} kan settes utenfor integraltegnet i (5.4). Under disse forutsetninger kan vi skrive integralet i (5.4) som en sum av to integraler slik at

$$\eta(x, t) = \frac{Qe^{\varepsilon t}}{2\pi\rho} [I_1 + I_2] \quad (5.5)$$

hvor

$$I_{1,2} = \int_0^{\infty} \frac{e^{\pm ikx}}{kU^2 \mp 2i\varepsilon U - g} dk.$$

Indeks 1 og 2 tilsvarer her henholdsvis øvre og nedre fortegnvalg i integranden. Under forutsetning av at ε er en liten størrelse har vi nå sløffet ε^2 . I det komplekse k -planet har således integralene $I_{1,2}$ poler for

$$k_{1,2} = \frac{g}{U^2} \pm \frac{2\varepsilon}{U}i$$

henholdsvis.

Skal vi for eksempel beregne integralet I_1 må vi skille mellom tilfellene $x > 0$ og $x < 0$. I det første tilfellet ($x > 0$) integrerer vi langs den reelle k -aksen til $k = \infty$, deretter langs en sirkelbane i det uendelig fjerne hvor integranden

$\rightarrow 0$, til den imaginære akse, og så tilbake til origo langs den sistnevnte akse (se figur 5.3). Denne lukkede kurven omslutter polen, og integralet langs kurven er derfor lik $2\pi i$ ganger residuet. I det andre tilfellet $x < 0$, velger vi en tilsvarende integrasjonskurve i 4. kvadrant. Denne vil følgelig ikke omslutte polen. I figur 5.4 er polene avmerket, og de to forskjellige integrasjonsveiene for I_1 skissert. På tilsvarende måte kan man gå frem når man skal beregne integralet I_2 bare med den forskjell at man må velge integrasjonsveien i 1. kvadrant for $x < 0$ og i 4. kvadrant for $x > 0$.

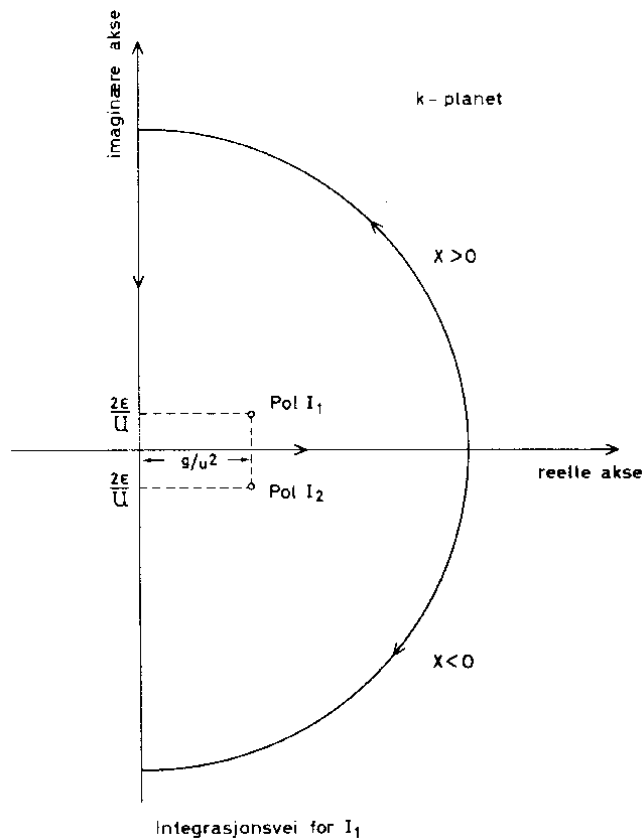

Figure 5.4: Integrasjonskontur.

Resultatet av disse beregningene gir for $\varepsilon \rightarrow 0$

$$I_1 + I_2 = -\frac{4\pi}{U^2} \sin k_s x + \frac{2}{U^2} \int_0^\infty \frac{k e^{-kx}}{k^2 + k_s^2} dk \quad x > 0$$

og

$$I_1 + I_2 = \frac{2}{U^2} \int_0^\infty \frac{k e^{kx}}{k^2 + k_s^2} dk \quad x < 0$$

hvor bølgetallet $k_s = g/U^2$. Vi legger merke til at denne bølgen har fasehastighet $c = U$ slik at den er stasjonær i forhold til forstyrrelsen. Går vi langt bort fra

forstyrrelsen vil integralene i uttrykket for $I_1 + I_2$ bare gi små bidrag, og vi vil ha en stasjonær overflateform $\eta = \eta_s(x)$ som med god tilnærming kan skrives

$$\begin{aligned}\eta_s(x) &= -\frac{2Q}{\rho U^2} \sin k_s x & x > 0 \\ \eta_s(x) &\simeq 0 & x < 0\end{aligned}\quad (5.6)$$

Vi legger til slutt merke til at innføringen av størrelsen ε var påkrevet for å få et entydig svar for $\varepsilon \rightarrow 0$. Hadde vi satt $\varepsilon = 0$ i (5.5), ville polene blitt liggende på integrasjonsveien og følgelig ført til en flertydighet i løsningen. Denne flertydigheten hadde gitt seg utslag i at den stasjonære bølgen kunne ligge oppstrøms og nedstrøms for forstyrrelsen. Det finnes også andre måter for å unngå flertydigheten, blant annet kan man innføre en liten kunstig friksjon proporsjonal med hastigheten (Lamb 1932, s. 242). Problemene med flertydighet er diskutert av Palm (1953) i et arbeid om le-bølger i atmosfæren.

Exercises

1. Bestem den stasjonære overflateformen forårsaket av en punktformet trykkforstyrrelse i det tilfellet at H er endelig. Diskuter spesielt tilfellene $U < \sqrt{gH}$ og $U > \sqrt{gH}$.
2. Bestem på tilsvarende måte den stasjonære overflateformen for kapillarbølger på dypt vann.

5.3 Skipsbølgeomønstret

Til nå har vi studert bølgeomønstret fremkommet av forstyrrelser som har hatt uendelig utstrekning på tvers av strømretning. Dersom forstyrrelsen har en endelig utstrekning, vil det utvikle seg et to-dimensjonalt bølgeomønstre på overflaten. Slike stasjonære bølgeomønstre kan en for eksempel iaktta bak skip som beveger seg med jevn fart (figur 5.5), eller i tilknytning til en kvist som berører overflaten i en bekk hvor vannet renner med jevn fart. Satelittbilder har vist at tilsvarende bølgeomønstre opptrer i atmosfæren når luften strømmer forbi en isolert fjelltopp. Det er nylig blitt kjent at Beerenberg på Jan Mayen skaper slike bølgeomønstre (figur 5.6).

Det mest karakteristiske trekk ved skipsbølgeomønstret er at bølgebevegelsen bare forekommer innenfor en viss sektor som stråler ut fra skipet. Dersom skipet beveger seg over dypt vann, er sektorens vinkel 39° , og den er uavhengig av skipets fart.

Vi antar at et skip seiler med konstant fart U langs en rett kurs. I løpet av en tid t har skipet beveget seg en distanse Ut fra posisjon B til posisjon A (se figur 5.7). På hvert sted langs ruten skaper skipet bølger som brer seg utover i alle



Figure 5.5: Skipsbølgeomønstre i Geirangerfjorden. (Foto Røstad).

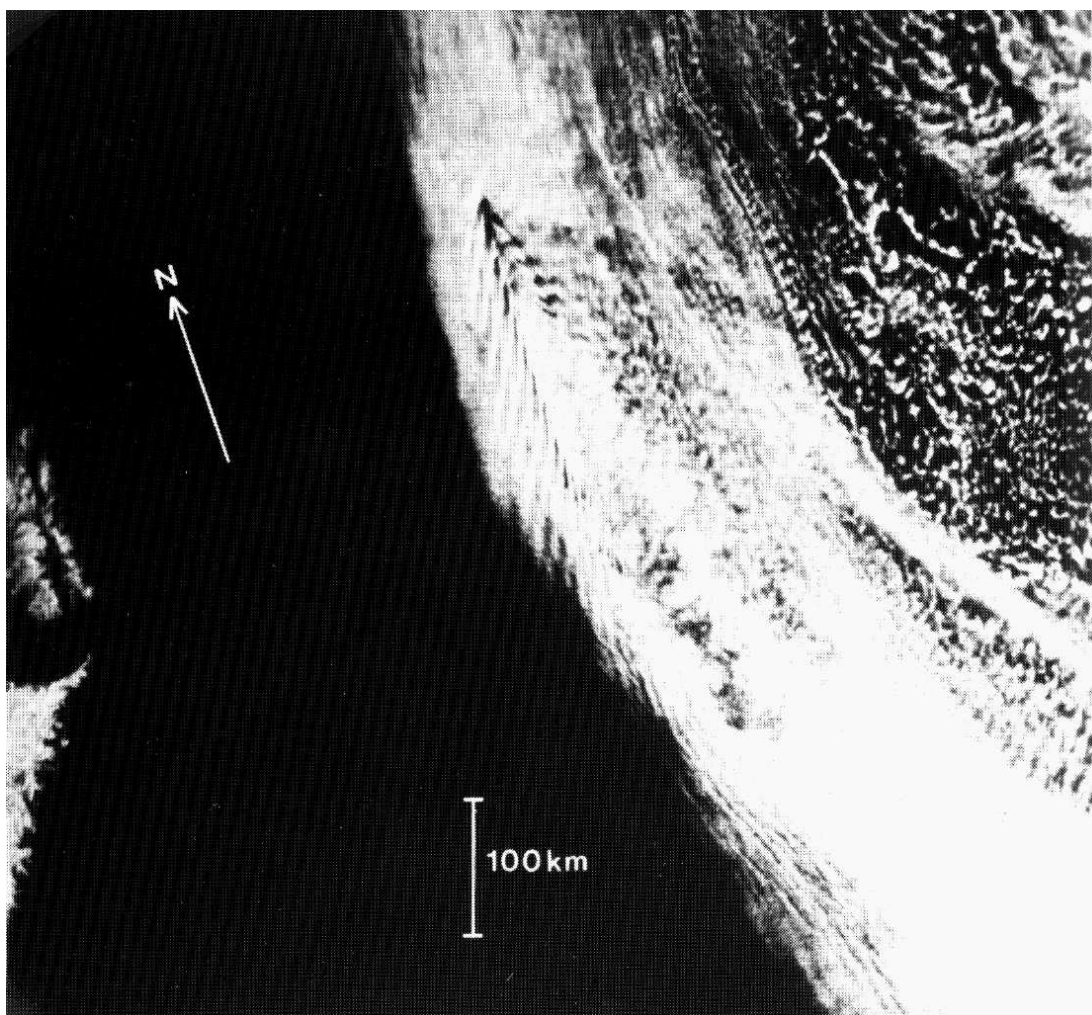

Figure 5.6: Satellittbilde som viser “skipsbølgeomønstret” i skydekket ved Jan Mayen 1. september 1976.

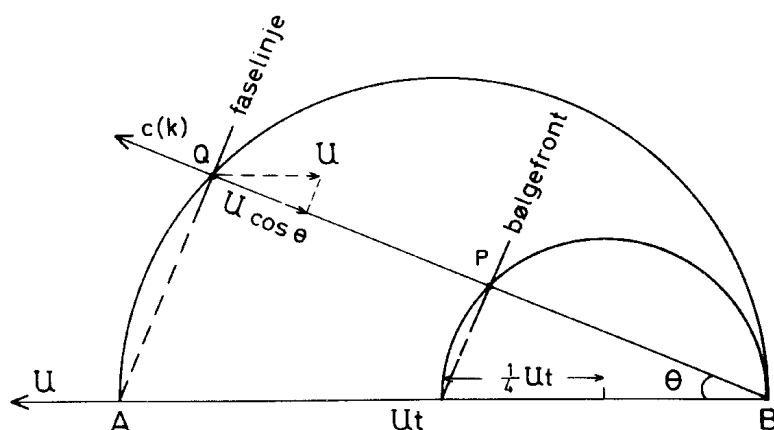

Figure 5.7:

retninger og interfererer med hverandre. Vi skal søke de bølgene som holder seg stasjonære i forhold til skipet. Vi betrakter derfor bølger som ble sendt ut mens skipet var i B langs en stråle BQ som danner en vinkel θ med AB . Betingelsen for at disse bølgene skal være stasjonære er at

$$c(k) = U \cos \theta \quad (5.7)$$

hvor $c(k)$ er fasehastigheten for en bølgekomponent med bølgetall k . Nå forplanter bølgeenergien seg med gruppehastigheten c_g , og for tyngdebølger er $c_g \leq c$. Overflateformen for bølgene som ble sendt ut i B langs strålen BQ er derfor å finne et sted på strålen mellom punktene B og Q . For tyngdebølger på dypt vann er $c_g = \frac{1}{2}c$, og bølgene er derfor kommet frem til et punkt P midtveis mellom Q og B . De stasjonære bølgene som ble sendt ut i B , vil derfor ligge på en sirkel gjennom P og B med radius $\frac{1}{4}Ut$.

Vi kan konstruere tilsvarende sirkler som angir bølgefronten for stasjonære bølger som ble sendt ut i punkter langs AB . Dette er skissert på figur 5.8. Sirklene avgrensner en sektor hvor den halve åpningsvinkelen θ_s er bestemt ved

$$\sin \theta_s = \frac{\frac{1}{4}Ut}{\frac{3}{4}Ut} = \frac{1}{3}.$$

Det stasjonære bølgemønsteret bak et skip som beveger seg med konstant fart over dypt vann, vil følgelig ligge innenfor en sektor med åpningsvinkel $2\theta_s = 39^\circ$. Dersom skipet beveger seg over grunt vann, så vil

$$\frac{1}{2}c < c_g < c$$

og dette medfører at vinkelen θ_s får en verdi mellom 19.5° og 90° slik at $\theta_s \rightarrow 90^\circ$ når $c_g \rightarrow c$.

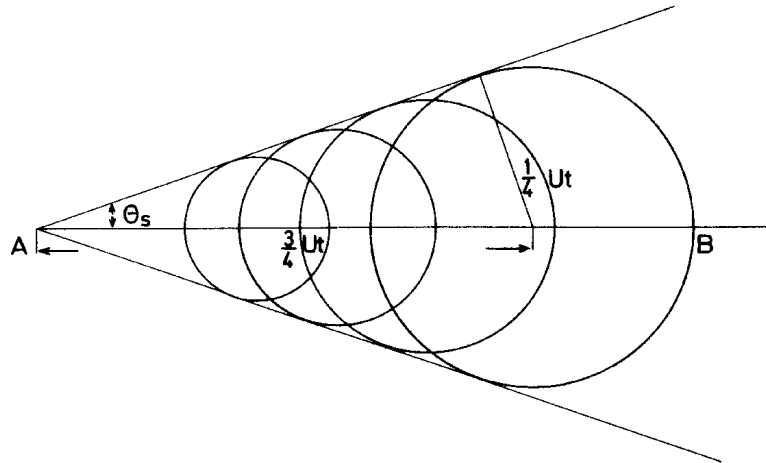

Figure 5.8:

Dette enkle resonementet som vi har gjennomført her, gir oss ingen informasjon om bølgeomønstrets utseende og bølgenes amplitude. Det er faktisk en formidabel oppgave å bestemme dette for et skipsskrog av vilkårlig form, og den oppgaven er ennå ikke løst i sin alminnelighet. Her skal vi begrense oss til å bestemme bølgeomønstret i det tilfellet at skipet erstattes med en punktformet forstyrrelse på overflaten. I det følgende presenteres to mulige framgangsmåter, og for øvrig henvises til Newman (1977).

Framgangsmåte I

La oss for enkelthets skyld tenke oss at forstyrrelsen (S) står stille og at vannet beveger seg med konstant hastighet U i x -retning (figur 5.9). Bølgeformen tenkes beskrevet med en fasefunksjon ϕ hvor faselinjen $\phi = \text{konstant}$ angir for eksempel en bølgetopp. Bølgetallsvektoren er da

$$\mathbf{k} = \nabla \phi. \tag{5.8}$$

En bølgekomponent som i stillestående vann forplanter seg med fasehastighet $c_0(k)$ vil føres med strømmen slik at fasehastigheten i forhold til et fast aksekors blir

$$c = c_0(k) + \mathbf{U} \cdot \frac{\mathbf{k}}{k}. \tag{5.9}$$

For stasjonære bølger er $c = 0$, og ved å sette (5.8) inn i (5.9) fremkommer det en differensiallikning for ϕ . Vi skal løse denne differensiallikningen ved å innføre karakteristikk slik at bølgetallsvektorene $k_x = \frac{\partial \phi}{\partial x}$ og $k_y = \frac{\partial \phi}{\partial y}$ er konstante langs disse linjene. Denne metoden er beskrevet av Whitham (1974). Med $c = 0$

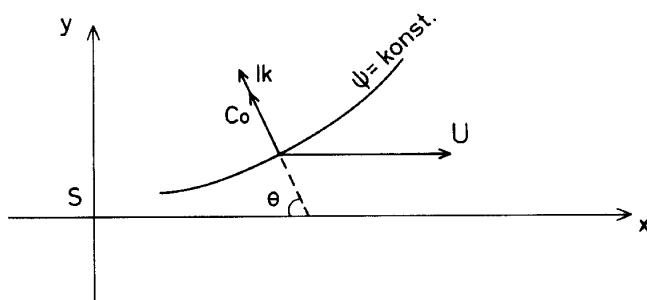

Figure 5.9:

er (5.9) en likning for k_x og k_y som vi kan skrive

$$F(k_x, k_y) = 0 \quad (5.10)$$

hvor F betegner en funksjon av bølgetallskomponentene. Dette betyr at k_x kan uttrykkes ved en funksjon av k_y , og vi skriver

$$k_x = f(k_y). \quad (5.11)$$

Fra likning (5.8) følger at $\nabla \times \mathbf{k} = 0$ slik at

$$\frac{\partial k_y}{\partial x} - \frac{\partial k_x}{\partial y} = 0.$$

Setter vi inn for k_x fra (5.11) kan den siste likningen skrives

$$\left(\frac{\partial}{\partial x} - f'(k_y) \frac{\partial}{\partial y} \right) k_y = 0.$$

Dette betyr at k_y er konstant på en linje eller karakteristikk $y = y(x)$ slik at

$$\frac{dy}{dx} = -f'(k_y).$$

Det følger fra (5.11) at også k_x er konstant langs denne linjen. Vi integrerer siste likning og velger integrasjonskonstanten slik at karakteristikken går gjennom origo

$$y = -f'(k_y)x. \quad (5.12)$$

Ved å derivere (5.10) med hensyn på k_y finner vi

$$\frac{\partial F}{\partial k_y} + \frac{\partial F}{\partial k_x} f'(k_y) = 0$$

slik at (5.12) kan skrives

$$\frac{y}{x} = \frac{\partial F}{\partial k_y} / \frac{\partial F}{\partial k_x}. \quad (5.13)$$

Ved hjelp av (5.10) kan vi finne k_x og k_y som funksjoner av x og y . Ved å integrere $\nabla\phi$ langs karakteristikken hvor k_x og k_y er konstant, får vi at fasefunksjonen $\phi = k_x x + k_y y$. Linjer med konstant fase er derved gitt ved

$$\phi = k_x x + k_y y = -A \quad (5.14)$$

hvor A er en konstant. Fortegnssvalget av A sammen med fortegnet på k_x avgjør bølgeomønstrets plassering på lo- eller le-siden.

Som eksempel på hvordan den foregående teorien kan benyttes, skal vi bestemme faselinjene for tyngdebølger på dypt vann. I dette tilfellet kan vi skrive

$$F(k_x, k_y) = U k_x + \sqrt{gk} = 0.$$

Vi innfører nå vinkelen θ (se figur 5.8) definert ved

$$\cos \theta = -\frac{k_x}{k} \quad \sin \theta = -\frac{k_y}{k}$$

og velger $-\frac{\pi}{2} < \theta < \frac{\pi}{2}$. Derved finner vi at

$$k = \frac{g}{U^2 \cos^2 \theta}$$

og

$$\frac{\partial F}{\partial k_x} = U \left(1 - \frac{1}{2} \cos^2 \theta\right), \quad \frac{\partial F}{\partial k_y} = \frac{U}{2} \sin \theta \cos \theta.$$

Ved innsetning i (5.13) og (5.14) finner vi en parameterfremstilling for linjene med konstant fase

$$\begin{aligned} x &= A \frac{U^2}{g} \cos \theta (1 + \sin^2 \theta) \\ y &= A \frac{U^2}{g} \cos^2 \theta (1 + \sin \theta) \end{aligned} \quad (5.15)$$

hvor A er en konstant. Velger man for eksempel $A = 2\pi n$ hvor $n = 1, 2, \dots$, finner man en skare med faselinjer bak skipet med avstand fra hverandre som tilsvarer den lokale bølgelengden. Et slikt sett av faselinjer er tegnet i figur 5.10. Faselinjene ender i en spiss for verdier av θ slik at y , for en gitt A , har et maksimum eller minimum. I disse punktene er $\sin^2 \theta = \frac{1}{3}$, og derved er

$$\left|\frac{y}{x}\right| = \frac{1}{4}\sqrt{2}.$$

Siden $\arctan\left(\frac{1}{4}\sqrt{2}\right) = 19.5^\circ$, viser dette at faselinjene ligger innenfor en sektor med åpningsvinkel 39° .

Bølgeomønstret består av to bølgesystemer. Det ene har bølgekammer som ligger på tvers av skipets bevegelsesretning. Disse kalles tverrbølger eller hekkbølger.

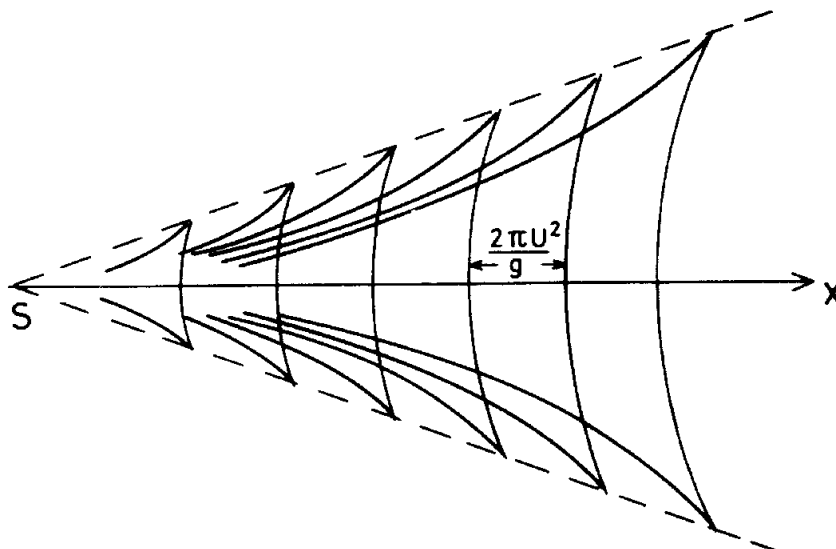

Figure 5.10:

Bølgelengden for hekkbølgene bak skipet er $\lambda = 2\pi U^2/g$. Bølgekammene for det andre bølgesystemet danner en vifte som sprer seg ut fra skipet. Disse bølgene kalles divergerende bølger eller baugbølger.

Metoden som vi har benyttet til å beregne faselinjene for skipsbølgeomønsteret er generell og kan anvendes for andre bølgetyper. Gjevik og Marthinsen (1978) beregnet for eksempel med samme metoden faselinjer for le-bølger i atmosfæren. De fant god overensstemmelse ved sammenlikning med bølgeomønstre på satellittbilder (figur 5.6).

For en punktformet forstyrrelse er det også mulig med relativt enkle metoder å bestemme amplituden for bølgene, og slike beregninger for skipsbølger er beskrevet blant annet av Lamb (1932) og Newman (1977).

Framgangsmåte II

Vi antar at en punktforstyrrelse som beveger seg i overflaten med hastighet $-\mathbf{U} = -U\mathbf{i}$ genererer et stasjonært og langsomt varierende bølgetog. Dette kan behandles med bølgekinematikk som beskrevet i kap. 3. Regnet i forhold til væsken har vi en isotrop dispersjonsrelasjon som gir en fasehastighet $c = c_0(k)$ der k er absoluttverdien av bølgetallsvektoren \mathbf{k} . Vi bytter nå koordinatsystem slik at forstyrrelsen blir liggende i ro. Vi får da frekvensen

$$\omega = c_0(k)k + \mathbf{U} \cdot \mathbf{k} \equiv W(k_x, k_y) \quad (5.16)$$

der k_x og k_y er komponentene av bølgetallsvektoren. W definert som ovenfor tilsvarer F tidligere. Vi merker oss at (5.16) gir *anisotrop* dispersjon pga. det

siste leddet som ofte betegnes Doppler-skift. At bølgeomønstret er stasjonært betyr i dette koordinatsystemet at $\omega = 0$. Dispersjonsrelasjonen (5.16) gir da umiddelbart en likning for k_x og k_y

$$W(k_x, k_y) = 0. \quad (5.17)$$

Gruppephasigheten er nå gitt ved

$$\mathbf{c}_g = \frac{\partial W}{\partial k_x} \mathbf{i} + \frac{\partial W}{\partial k_y} \mathbf{j}. \quad (5.18)$$

Da mediet er uniformt gir strålelikningene

$$\frac{d\mathbf{k}}{dt} = 0, \quad \frac{d\mathbf{r}}{dt} = \mathbf{c}_g \quad (5.19)$$

der

$$\frac{d}{dt} \equiv \frac{\partial}{\partial t} + \mathbf{c}_g \cdot \nabla. \quad (5.20)$$

Det følger umiddelbart at \mathbf{k} og derved \mathbf{c}_g er konstante langs karakteristikkene, slik at disse blir rette linjer. Bare de karakteristikkene kan bære energi som går gjennom forstyrrelsen, som vi uten tap av generalitet kan plassere i origo. Hvert forhold y/x svarer derfor til en karakteristikk og overalt i mediet har vi likningen

$$\frac{y}{x} = \frac{\frac{\partial W}{\partial k_y}}{\frac{\partial W}{\partial k_x}} \quad (5.21)$$

som sammen med (5.17) implisitt definerer k_x og k_y som funksjon av x og y . For å finne eksplisitte uttrykk kan fortsette på ulike vis. En mulighet er å benytte (5.17) til å uttrykke komponentene av bølgetallsvektoren vha. c_0 . Innsetting i (5.21) gir da en bikvadratisk likning for c_0 . En annen mulighet er å innføre vinkelen, θ , mellom \mathbf{k} og den negative x -retningen. Vi kan da sette

$$k_x = -k \cos \theta, \quad k_y = k \sin \theta. \quad (5.22)$$

Fra (5.17) følger da umiddelbart

$$k = \frac{g}{U^2 \cos^2 \theta}. \quad (5.23)$$

Vi merker oss at dette er en omskrivning av $U = c_0 / \cos \theta$. Innsetting i (5.21) fulgt av eliminering av k gir da

$$\frac{y}{x} = \frac{\cos \theta \sin \theta}{1 + \sin^2 \theta} \equiv f(\theta). \quad (5.24)$$

Høyresiden, $f(\theta)$, har maksimum for $\sin \theta = \sqrt{1/3}$, dvs $\theta = \theta_c \approx 35.3^\circ$. Dette svarer til $y/x = \sqrt{2}/4$ som er identisk med den ytterbegrensning av bølgeomønstret

som er funnet tidligere. For $y/x < \sqrt{2}/4$ finner vi to løsninger for θ , en som er mindre enn θ_c og en som er større. Disse to grenene definerer hver sin fasefunksjon og derved hvert sitt bølgefelt. Den første definerer de såkalte *hekkbølger*, mens det andre gir *baugbølger*. Likning (5.24) kan lett omskrives til en bikvadratisk likning for $\sin \theta$,

$$\left(1 + \left(\frac{y}{x}\right)^2\right) \sin^4 \theta + \left(2 \left(\frac{y}{x}\right)^2 - 1\right) \sin^2 \theta + \left(\frac{y}{x}\right)^2 = 0, \quad (5.25)$$

som har fire løsninger for $(y/x)^2 < 1/8$, tilsvarende de to bølgefeltene definert for positive og negative y .

For fasefunksjonen kan vi sette opp integralet

$$\chi(\mathbf{r}) = \chi_0 + \int_{C(\mathbf{r})} \mathbf{k} \cdot d\mathbf{r} \quad (5.26)$$

der χ_0 er fasen i origo og $C(\mathbf{r})$ betegner en hvilken som helst kurve som starter i origo og slutter i \mathbf{r} . I dette tilfellet får vi triviell regning dersom vi integrerer langs karakteristikkene

$$\chi(\mathbf{r}) = \chi_0 + k_x x + k_y y \quad (5.27)$$

der k_x og k_y jo er kjente som funksjoner av x og y . Hver verdi av χ definerer en faselinje. Vi uttrykker bølgetallskomponentene vha. θ også i (5.27). Likningene (5.21) og (5.27) kan så løses mhp. x og y og vi finner en parameterisering av faselinjene ($\chi = -A = \text{konstant}$)

$$x = \frac{(A + \chi_0)U^2}{g} \cos \theta (1 + \sin^2 \theta), \quad (5.28)$$

$$y = \frac{(A + \chi_0)U^2}{g} \cos^2 \theta \sin \theta. \quad (5.29)$$

For $|\theta| < \theta_c$ beskriver disse faselinjer for hekkbølger, mens de for $|\theta| > \theta_c$ gir faselinjer for baugbølger, eller divergerende bølger. Siden disse to feltene er uavhengig behøver de ikke ha samme χ_0 . Stråleteorien bryter sammen i ytterkant av bølgemønstret, for $\theta \approx \pm \theta_c$.

Ved stråleteori får vi ikke bestemt fasen χ_0 . For en punktforstyrrelse kan det vises, f.eks. ved bruk av stasjonær fase etter Fourier transform, at $\chi_0 = \frac{1}{4}\pi, -\frac{1}{4}\pi$ for henholdsvis hekk- og baugbølger (se f.eks. Newman (1977)). Disse verdiene er brukt i figure 5.11. I figur 5.12 har vi også tegnet inn den geometriske stedet som nåes ved gruppehastighet fra et valgt punkt. Figuren viser også "energi-transportbanene" fram til krysningspunktene med faselinjer.

Exercises

1. Bestem faselinjene for stasjonære kapillarbølger på dypt vann generert av en punktformet forstyrrelse som beveger seg med konstant fart.

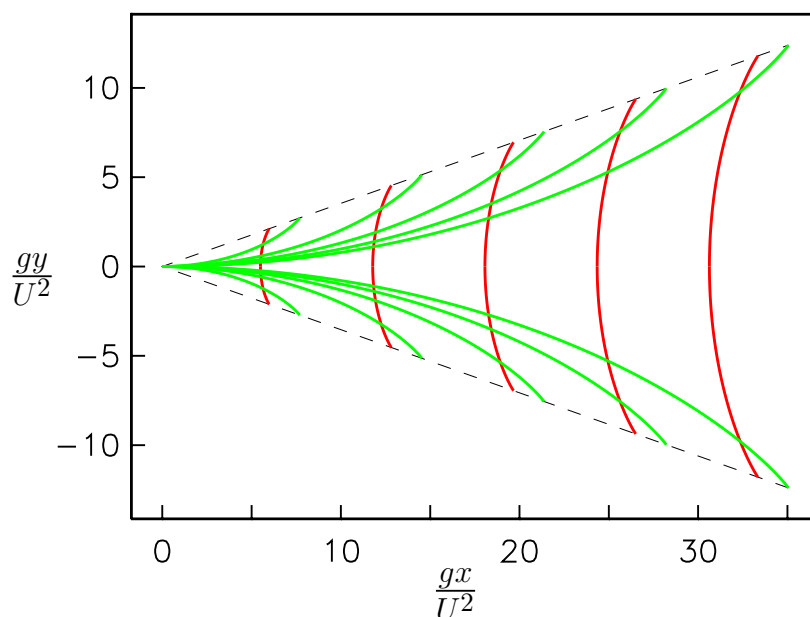

Figure 5.11: Fase-diagram for de to bølgesystemene bak en punktforstyrrelse på uendelig dyp. Vi har tegnet faselinjer som svarer til $\chi = -2n\pi$, $n = 1, 2, \dots, 5$.

- Bestem faselinjene for tyngdebølger på vann av endelig dyp generert av en punktformet forstyrrelse som beveger seg med konstant fart. Tegn opp faselinjene i to tilfeller $U < \sqrt{gH}$ og $U > \sqrt{gH}$.

5.4 Wave resistance

When a disturbance moves along the surface such that a stationary wave pattern arises, then the water will be constantly added energy in such a way that the size of the region affected by the wave motion increases. This energy must be transferred by the work done by the disturbance, and this has the consequence that one has to exert a force R to move the disturbance with constant velocity. This force is denoted *wave resistance*. We shall find an expression for this force for plane (two-dimensional) wave motion behind a disturbance that moves with constant velocity U . The stationary wave pattern has amplitude a , and according to (2.32) the average wave energy for gravity waves per unit of length along the surface is

$$E = \frac{1}{2} \rho g a^2$$

where ρ is the water density. In front of and behind the disturbance we construct vertical control planes, respectively I and II (figure 5.13). We then look at the increase in energy within the liquid volume delimited by the planes I and II

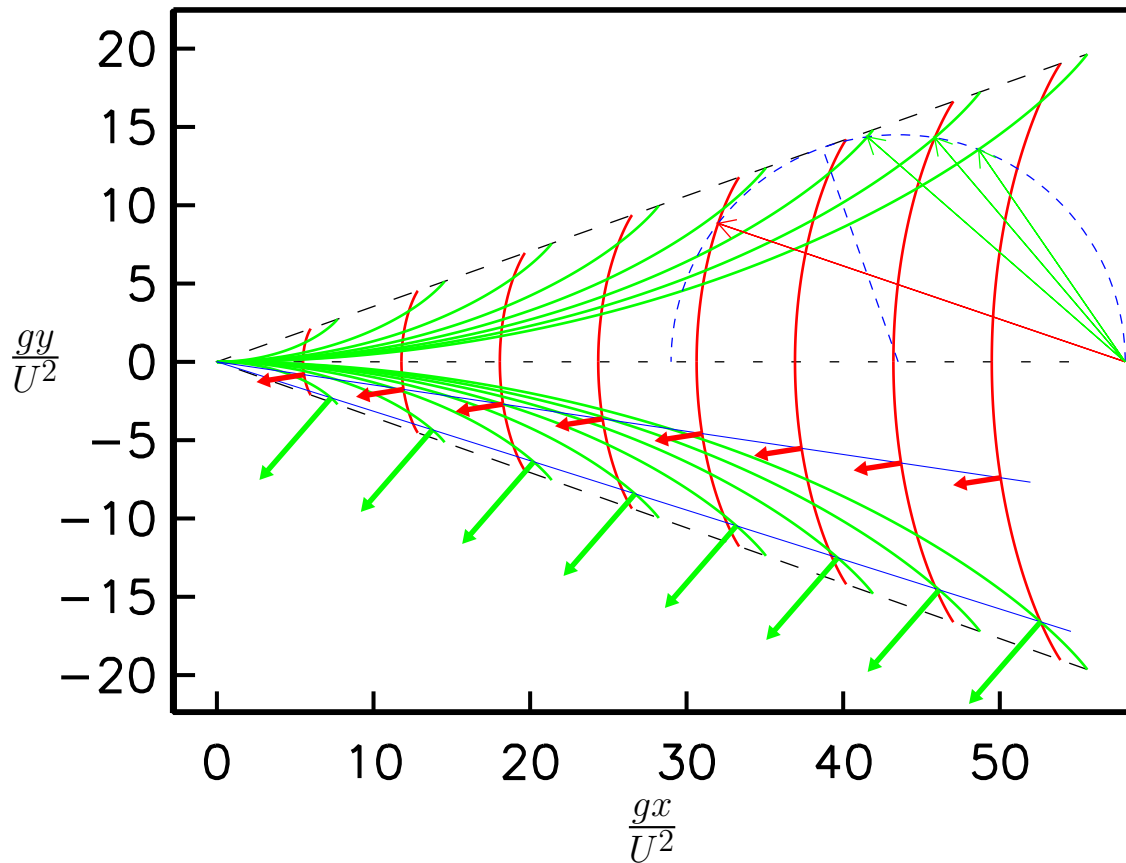

Figure 5.12: Fasediagram for Kelvin's skipsbølgeomønster. Den stiplede halvsirkelen angir de geografiske steder dit gruppehastigheten bringer oss fra stedet der halvsirkelen krysser x -aksen til høyre. Dette betyr at energien som forstyrrelsen tilførte det stasjonære bølgesystemet da den passerte dette punktet nå befinner langs den stiplede sirkelen (og dens speilbilde under y -aksen). Pilene fra punktet og til bølgetoppenes skjæring med sirkelen svarer da til bølgebaner i det koordinatsystemet der forstyrrelsen beveger seg. Vi merker oss at bølgebanene er vinkelrette på kammene.

I det nedre halvplanet er to karakteristikkert inntegnet. Langs den øverste (skalerte) bølgetallsvektorer tilhørende hekkbølger inntegnet, mens langs den nedre har vi tegnet inn bølgetallsvektorene for baugbølger.

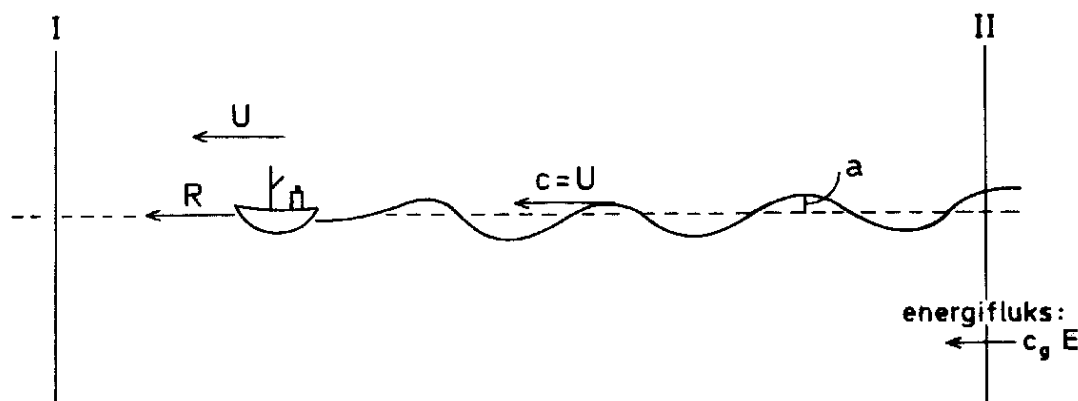

Figure 5.13:

within a time interval Δt . The work done by the propulsion force R is $RU\Delta t$. The increase in wave energy within the liquid volume due to the wave train becoming longer, is $Ec\Delta t$. There is also a flux of wave energy $c_g E\Delta t$ into the volume at the plane II . The energy balance for the liquid volume within the control planes is therefore

$$RU\Delta t + c_g E\Delta t = Ec\Delta t.$$

Thereby we find that the wave resistance on the disturbance can be written

$$R = \frac{c - c_g}{c} E.$$

For gravity waves on deep water $c_g = \frac{1}{2}c$ and

$$R = \frac{1}{4} \rho g a^2.$$

If one uses the computed amplitude for a stationary wave behind a point pressure disturbance (section 5.2), we find that in this case the wave resistance decreases with increasing velocity.

Methods for computing wave resistance when one accounts for the three-dimensional structure of the ship wake pattern are described by Newman (1977).

5.5 Overflatebølger modifisert av strøm som varierer i styrke i horisontal retning

Vi skal her kort vise hvordan overflatebølger blir modifisert når de forplanter seg inn i et område med gradvise endringer i strømhastigheten i horisontal retning.

Dette fenomenet kan iakttas i naturen hvor bunntopografien eller utstrømning av vann fra elveutløp fører til horisontale variasjoner i strømhastigheten. Vi begrenser oss til plane bølger som forplanter seg i x -aksens retning mot en strøm med hastighet $U(x)$ som er en funksjon av x , se figur 5.14. Vi antar at strømmen

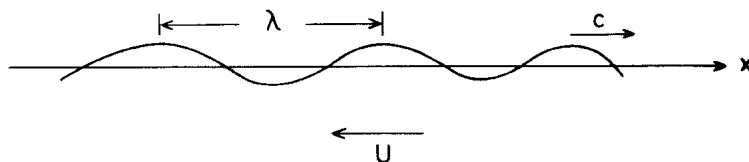

Figure 5.14:

er langsomt varierende slik at

$$\left| \frac{\lambda}{U} \frac{dU}{dx} \right| \ll 1$$

hvor λ er bølgelengde. Lokalt vil derfor bølgene være tilnærmet upåvirket av endringene i strømmen. På hvert enkelt sted kan vi da regne som om bølgene forplanter seg på en uniform strøm. Med de definerte retninger kan fasehastighet i forhold til et fast aksekors skrives

$$c = c_0 - U$$

hvor $c_0 = \sqrt{g/k}$ er fasehastighet for tyngdebølger på dypt vann. Betrakter vi periodisk bevegelse med fast frekvens ω_0 , så har vi følgelig at

$$ck = \sqrt{gk} - Uk = \omega_0.$$

Deriverer vi den siste likningen med hensyn på x får vi

$$\frac{dk}{dx} = \frac{2 \frac{dU}{dx} k}{c_0 - 2U}.$$

Dette viser at for $c_0 > 2U$ så vil bølgetallet øke og bølgelengden avta når bølgene forplanter seg mot en strøm av økende styrke. Dersom strømvariasjonen er så stor at U nærmer seg $c_0/2$, så vil endringen i bølgelengde bli så stor at forutsetningene for denne teorien ikke er oppfylt. Grenseverdien $U = c_0/2$ tilsvarer at bølgenes gruppehastighet blir lik strømhastigheten. Energien i bølgebevegelsen kan da ikke lenger forplante seg opp mot strømmen, og dette leder til en opphopning av bølgeenergi. Vi har sett at bølgelengden avtar mot null inn mot det området hvor $U = c_0/2$. Med konstant energiflukt forventer vi at bølgeamplituden øker over alle grenser. De kraftige effektene som er beskrevet her vil opptre i områder med sterk strøm og for korte bølgelengder hvor fasehastigheten er relativt liten. Svak

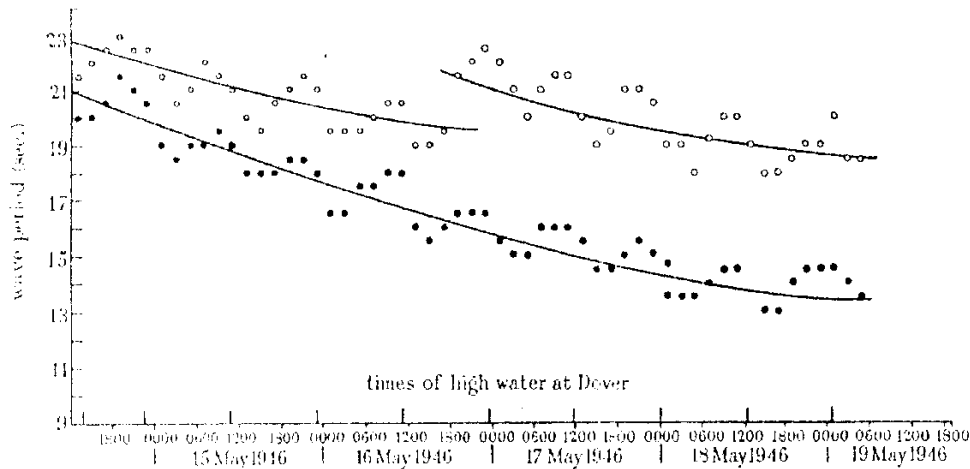

Figure 5.15: Modulasjoner av perioden for dønning forårsaket av tidevannsstrømmen. Tre episoder observert ved kysten av Cornwall, England. (Etter Barber 1949)

frekvensmodulasjon av langeperiodiske dønninger på grunn av tidsvarierende tidevannsstrøm har også blitt observert, se figur 5.15.

Exercises

- Bestem frekvensmodulasjonen for tyngdebølger på dypt vann som forplanter seg mot en uniform strøm $U(t) = U_0 \sin \Omega t$. Perioden $2\pi/\Omega$ antas å være mye lenger enn middelperioden T_0 for bølgene. Finn et enkelt uttrykk for perioden når strømhastigheten U_0 er mye mindre enn fasehastigheten c_0 for bølgene i rolig vann. Benytt dataene i figur 5.15 til å estimere tidevannsstrømmens styrke.
- For bølger på en langsomt varierende grunnstrøm, U , kan vi anta en dispersjonsrelasjon på formen

$$\omega = \sigma + \mathbf{k} \cdot \mathbf{U}$$

der σ er frekvensen vi ville hatt uten strøm, på engelsk kalt *intrinsic frequency*. Det siste leddet kalles Doppler-skiftet.

I denne oppgaven ser vi på lange, lineære overflatebølger på grunt vann og antar at grunnstrømmen er gitt ved $U \equiv -U(x)\mathbf{j}$ der \mathbf{j} er enhetsvektoren i y -retning. Videre antas at U har en klokkefasong

$$U = U_m e^{-\frac{x^2}{l^2}}$$

I en slik strøm kan vi ha fangede bølger.

- a Gi en fysisk redegjørelse for fangningsmekanismen.
- b Anta at vi har et gitt bølgetall i y -retning. Finn begrensninger på mulige ω for fangede moder ved stråleteori.
- c Sett opp det fulle lineære egenverdi-problemet som bestemmer egenmodene.
3. Fra forrige oppgave punkt (c) har vi at bølgebevegelsen i en planparallel grunnstrøm er styrt av likningen

$$\left(\frac{\hat{\eta}_x}{P}\right)_x + \left(1 - \frac{k_y^2}{P}\right)\hat{\eta} = 0; \quad P \equiv (\omega + Uk_y)^2/(gh)$$

der grunnstrømmen U varierer med x og $\hat{\eta}$ relaterer seg til overflaten i henhold til

$$\eta(x, y, t) = \text{Re} \left(\hat{\eta}(x) e^{i(k_y y - \omega t)} \right)$$

Benytt WKBJ metoden til å finne tilnærmelser til $\hat{\eta}$. Hvor er de gyldige? Svarer resultatet til energikonservering i bølgebevegelsen?

Chapter 6

INTERNE TYNGDEBØLGER

Interne tyngdebølger kan opptre i atmosfæren, havet og innsjøer og skyldes oppdriftskraften på grunn av den vertikale tetthetssjiktningen. Selv om tetthetssjiktningen kan ha forskjellige årsaker, såsom variasjoner i temperatur, saltholdighet, eller konsentrasjoner av andre oppløste stoffer, så er mange egenskaper ved bølgebevegelsen like. Den primære årsaken til de interne bølgene er oppdriftskraften, men bølgebevegelsen vil i mange tilfeller være modifisert av forskjellige andre årsaker, i første rekke kompressibilitet og diffusjonsprosesser. Langperiodiske interne bølger i naturen vil dessuten ofte være betydelig påvirket av Corioliskraften. For relativt kortperiodiske interne bølger i vann eller hav kan væsken regnes som inkompressibel, og dessuten vil bølgebevegelsen være tilnærmet upåvirket av endringer i tetthet som følge av langsom diffusjon av varme eller salt.

Det er i særdeleshet én parameter som har fundamental betydning når man skal beskrive interne bølger. Dette er oppdriftsfrekvensen eller Väisälä–Brunt frekvensen. Vi skal innledningsvis definere denne størrelsen og gi den en enkel fysikalsk tolkning. Ved likevekt er tettheten ρ_0 konstant langs horisontale flater, og ρ_0 er en funksjon av den vertikale koordinaten z som for eksempel kan stå for dypet.

En væskepartikkel som føres i vertikal retning en avstand Δz ut fra likevektsstillingen, se figur 6.1, vil være påvirket av en oppdriftskraft pr. volumenhet

$$-g[\rho_0(z + \Delta z) - \rho_0(z)] \simeq -g \frac{d\rho_0}{dz} \Delta z$$

som søker å føre partikkelen tilbake til likevektsstillingen. Partikkelens masse pr. volumenhet ganget med akselerasjonen er

$$\rho_0 \frac{d^2}{dt^2}(\Delta z).$$

Dersom vi neglisjerer trykk-kraften, kan bevegelseslikningen for partikkelen skrives

$$\frac{d^2}{dt^2}(\Delta z) = -N^2 \Delta z \quad (6.1)$$

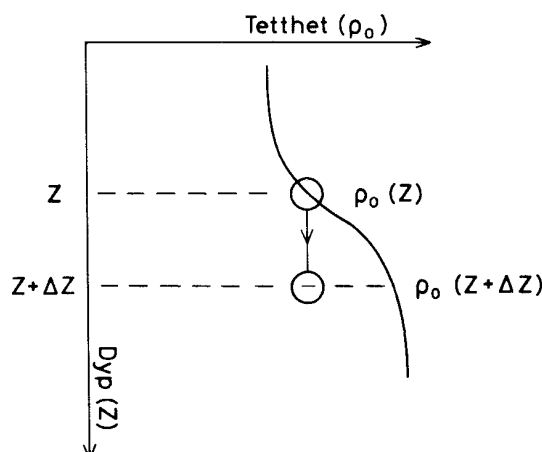

Figure 6.1:

hvor størrelsen

$$N = \left(\frac{g}{\rho_0} \frac{d\rho_0}{dz} \right)^{\frac{1}{2}} \quad (6.2)$$

er *oppdriftsfrekvensen*. Likning (6.1) sier at væskepartikkelen utfører vertikale svingninger med frekvens N . Utenom dette gir denne enkle modellen hvor trykkkreftene er neglisjert, ingen informasjon om egenskapene ved bølgebevegelsen.

6.1 Interne bølger i inkompressible væsker hvor diffusjonsprosessen kan neglisjeres. Dispersjonsegenskaper og partikkelbevegelse.

Bølgebevegelsen fører til hastighetsperturbasjoner som kan uttrykkes ved vektoren \mathbf{v} som har komponenter u , v og w henholdsvis langs x -, y - og z -aksen. De to førstnevnte aksene ligger i horisontalplanet, og z -aksen angir som før dypet. Bevegelsen medfører at tettheten endres i forhold til den verdien tettheten har ved likevekt. Vi betegner tetthetsendringen med ρ , og den totale tetthet på et bestemt sted er $\rho_0 + \rho$. Vi antar at tetthetsendringene utelukkende skyldes forflytning av væskepartikler med bølgebevegelsen, og vi neglisjerer således tetthetsendringer på grunn av diffusjonsprosesser. Vi antar videre at bølgeamplituden er så liten at vi kan linearisere de likningene som beskriver bevegelsen. Siden ρ avhenger av bølgeamplituden, omfatter lineariseringen også at vi sløyfer produkter hvor for eksempel ρ og \mathbf{v} inngår. Under disse forutsetninger kan bevegelseslikningen, tilstandslikningen og kontinuitetslikningen skrives

$$\frac{\partial \mathbf{v}}{\partial t} = -\frac{1}{\rho_0} \nabla p + \frac{\rho}{\rho_0} \mathbf{g} \quad (6.3)$$

$$\frac{\partial \rho}{\partial t} = -w \frac{d\rho_0}{dz} \quad (6.4)$$

$$\nabla \cdot \mathbf{v} = 0 \quad (6.5)$$

hvor p er trykkendringen på grunn av bølgebevegelsen, og vektoren \mathbf{g} som er rettet i z -aksens retning betegner tyngdens akselerasjon.

Av likningene (6.3)–(6.5) kan vi eliminere p , u , v og ρ slik at vi blir stående igjen med en likning for vertikalhastigheten

$$\frac{\partial^2}{\partial t^2}(\nabla^2 w) + \frac{1}{\rho_0} \frac{d\rho_0}{dz} \frac{\partial^3 w}{\partial t^2 \partial z} = -N^2 \nabla_h^2 w \quad (6.6)$$

hvor

$$\nabla_h^2 \equiv \frac{\partial^2}{\partial x^2} + \frac{\partial^2}{\partial y^2}.$$

For å utlede (6.6) kan vi gå frem på følgende måte: Vektorlikningen (6.3) gir tre likninger for hastighetskomponentene

$$\begin{aligned} \frac{\partial u}{\partial t} &= -\frac{1}{\rho_0} \frac{\partial p}{\partial x} \\ \frac{\partial v}{\partial t} &= -\frac{1}{\rho_0} \frac{\partial p}{\partial y} \\ \frac{\partial w}{\partial t} &= -\frac{1}{\rho_0} \frac{\partial p}{\partial z} + \frac{\rho}{\rho_0} g \end{aligned}$$

Ved å derivere de to første av disse likningene henholdsvis med hensyn på x og y og addere får vi

$$\frac{\partial}{\partial t} \left(\frac{\partial u}{\partial x} + \frac{\partial v}{\partial y} \right) = -\frac{1}{\rho_0} \nabla_h^2 p.$$

På grunn av (6.5) kan dette skrives

$$\frac{\partial}{\partial t} \left(\frac{\partial w}{\partial z} \right) = \frac{1}{\rho_0} \nabla_h^2 p.$$

Derivasjon med hensyn på z gir

$$\frac{\partial}{\partial t} \left(\frac{\partial^2 w}{\partial z^2} \right) = -\frac{1}{\rho_0} \nabla_h^2 p \left(\frac{1}{\rho_0} \frac{d\rho_0}{dz} \right) + \frac{1}{\rho_0} \nabla_h^2 \frac{\partial p}{\partial z}.$$

Anvender vi nå operatoren ∇_h^2 på den siste av de tre komponentlikningene, kan vi eliminere trykket fra likningen ovenfor slik at vi får en likning hvor bare w og ρ inngår. Ved å bruke (6.4) kan vi også eliminere ρ . Derved fremkommer likningen (6.6).

Vi forventer at den viktigste effekten av tetthetssjiktningen er knyttet til oppdriftskraften som er representert ved leddet på høyre side i likning (6.6). Når

tetthetsendringene ved likevekt er små kan andre leddet på venstre side i den samme likningen sløyfes. Dette tilsvarer at man beholder den dynamiske effekten av tetthetssjiktningen, men sløyfer den kinematiske. Approksimasjonen betegnes Boussinesq-antagelsen, og den representerer i mange tilfeller en god tilnærmelse. Gyldigheten er diskutert senere i dette avsnittet. I lys av dette kan vi derfor skrive (6.6)

$$\frac{\partial^2}{\partial t^2}(\nabla^2 w) = -N^2 \nabla_h^2 w. \quad (6.7)$$

For konstant N søker vi bølgeløsning av formen

$$w = A \sin(\mathbf{k} \cdot \mathbf{x} - \omega t) \quad (6.8)$$

hvor A er en konstant. De tilhørende hastighetskomponenter i horisontalretningen er

$$u = -\frac{k_x k_z}{k_x^2 + k_y^2} A \sin(\mathbf{k} \cdot \mathbf{x} - \omega t)$$

og

$$v = -\frac{k_y k_z}{k_x^2 + k_y^2} A \sin(\mathbf{k} \cdot \mathbf{x} - \omega t)$$

hvor k_x , k_y og k_z betegner henholdsvis x -, y - og z -komponenten av bølgetallsvektoren.

Ved å sette uttrykket i (6.8) inn i likning (6.7) finner vi dispersjonsrelasjonen

$$\omega^2 = N^2 \frac{k_x^2 + k_y^2}{k^2} \quad (6.9)$$

Dette viser at interne tyngdebølger av formen (6.8) har vinkelfrekvens

$$\omega \leq N$$

og at oppdriftsfrekvensen er en øvre grense for de frekvenser som kan forekomme. Settes $\omega = N$ medfører det at bølgebevegelsen er uavhengig av z og at den vertikale komponenten av bølgetallsvektoren $k_z = 0$. Væskepartiklene beveger seg i dette tilfellet i vertikale plan ($u = v = 0$), og svingetiden er i samsvar med det vi fant innledningsvis. For gitte verdier av ω og N danner bølgetallsvektoren vinkelen

$$\theta = \arcsin\left(\frac{\omega}{N}\right)$$

med vertikalen. Når bevegelsen er periodisk i x , y og z , følger det fra kontinuitetslikningen (6.5) at

$$\mathbf{k} \cdot \mathbf{v} = 0$$

Dette viser at partikkelbevegelsen for de interne bølgene er rettet normalt til bølgetallsvektoren. Partikkelbevegelsen foregår følgelig i plan som er parallelle med faseflatene, se figur 6.2.

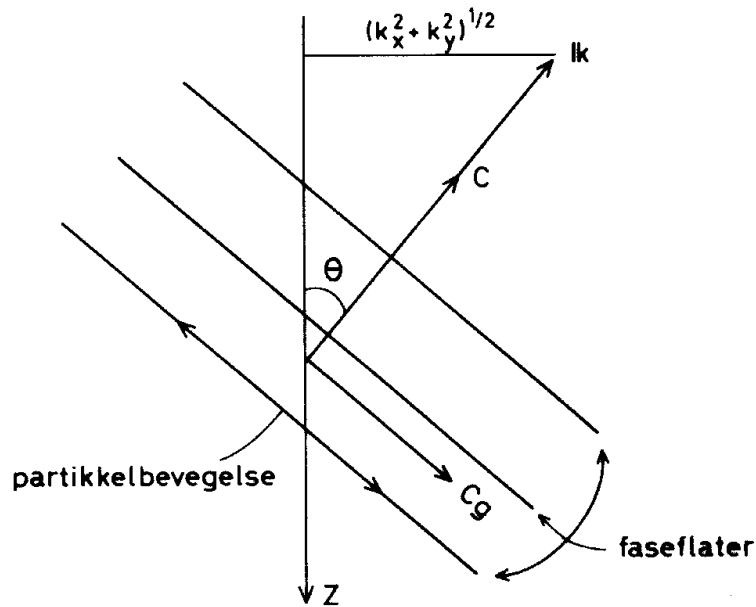

Figure 6.2:

I dispersjonsrelasjonen (6.9) inngår bølgetallsvektorens komponenter såvel som bølgetallsvektorens størrelse. Det betyr at vi har anisotrop dispersjon og at forplantningshastigheten er retningsavhengig. Ved anisotrop dispersjon faller ikke gruppehastigheten langs bølgetallsvektorens retning, og for interne tyngdebølger som følger dispersjonsrelasjonen (6.9), er gruppehastigheten rettet langs faseflatene. Gruppehastigheten har komponenter

$$\mathbf{c}_g = \left(\frac{\partial \omega}{\partial k_x}, \frac{\partial \omega}{\partial k_y}, \frac{\partial \omega}{\partial k_z} \right)$$

henholdsvis langs de tre koordinatretningene x , y og z . Med relasjonen (6.9) finner vi

$$\mathbf{c}_g = \frac{c}{k} \{ k_x \cot^2 \theta, k_y \cot^2 \theta, -k_z \} \quad (6.10)$$

Enkel regning gir at

$$\mathbf{c}_g \cdot \mathbf{k} = 0.$$

Dette viser at gruppehastigheten er rettet normalt på bølgetallsvektoren. Av (6.10) ser vi at horisontalkomponenten av \mathbf{c}_g og \mathbf{k} har samme retning og at vertikalkomponentene er motsatt rettet. Dette betyr at den vertikale energitransporten ved interne tyngdebølger er rettet i motsatt retning av den vertikale forflytning av faseflatene. På figur 6.2 er samhoørende retninger for bølgetallsvektor, gruppehastighet og partikkelbevegelse skissert.

Vi er nå istand til å angi under hvilke betingelser vi kan sløyfe andre leddet på venstre side av likning 6.6. Ved hjelp av 6.8 finner vi at forholdet mellom

andre og første ledd i likningen er

$$\left| \frac{1}{\rho_0} \frac{d\rho_0}{dz} \frac{k_z}{k^2} \right|$$

Dette viser at andre leddet kan sløyfes i forhold til det første når den relative tetthetsvariasjonen over en distanse tilsvarende k_z/k^2 er tilstrekkelig liten.

6.2 Interne bølger knyttet til sprangsjiktet

I havet og i innsjøer opptrer det ofte situasjoner med lagdeling av vannmassene i overflatelag og bunnlag hvor tettheten er tilnærmet uniform i hvert av lagene. I et tynt sjikt mellom lagene endrer tettheten seg forholdsvis raskt i vertikal retning. Dette sjiktet blir betegnet *sprangsjiktet*, og det oppstår ved blanding av vannmassene fra overflatelaget og bunnlaget. Tetthetsvariasjonen i sprangsjiktet skyldes forskjeller i saltholdighet eller temperatur. I fjorder opptrer det ofte et sprangsjikt i situasjoner med stor tilførsel av ferskvann som legger seg i overflaten, og i innsjøer opptrer sprangsjiktet som følge av oppvarming av overflatelaget.

Figur 6.3 viser en karakteristisk temperaturfordeling i øvre delen av en dyp innsjø i sommerhalvåret. Temperaturen fremstilt på figuren er middelveien for en angitt tidsperiode. Vi ser at overflatelaget er 15–20 m tykt og at temperaturen er omkring 14° . Sprangsjiktet strekker seg fra 20 til 30 meters dyp, og vannet under sprangsjiktet viser liten temperaturvariasjon med dypet. På grunnlag av temperatur-observasjonene kan man beregne tettheten ρ_0 , oppdriftsfrekvensen N og perioden $2\pi/N$. De to sistnevnte størrelsene er også fremstilt som funksjon av dypet i figur 6.3. I overflatelaget og bunnlaget er oppdriftsfrekvensen liten, mens sprangsjiktet er karakterisert med en stor verdi av N . Under slike forhold vil kraftig vind i innsjøens lengderetning transportere det varme overflatelaget i vindens retning slik at sprangsjiktet løftes i opp-vinds enden og senkes i ned-vinds enden. Når vinden løyer, vil hevingen og senkningen av sprangsjiktet forplante seg som indre bølger. Observasjoner av slike bølger i Mjøsa er beskrevet av Mørk, Gjevik og Holte (1980). Liknende fenomen er kjent fra mange andre innsjøer, blant annet Loch Ness i Skottland (Thorpe *et al.* 1972).

I fjorder vil skiftninger i tidevannsstrømmen over fjordterskler ofte gi opphav til indre bølger. Ved målinger i Herdlefjorden vest for Bergen ble dette påvist av Fjeldstad allerede i 30-årene. Observasjonene er senere publisert i et arbeid fra 1964 (Fjeldstad 1964). Indre tidevannsbølger har blitt påvist mange steder og under forskjellige forhold. Se for eksempel en oversiktsartikkel av Farmer og Freeland (1983). Stigebrand (1979) har funnet at slike bølger genereres ved Drøbak-terskelen i Oslofjorden.

I atmosfæren vil det under visse vær-situasjoner oppstå temperaturinversjoner eller isoterme lag, mens lagene over og under er i nær nøytral likevekt. Oppdriftsfrekvens som funksjon av høyden over bakken endrer seg under slike forhold

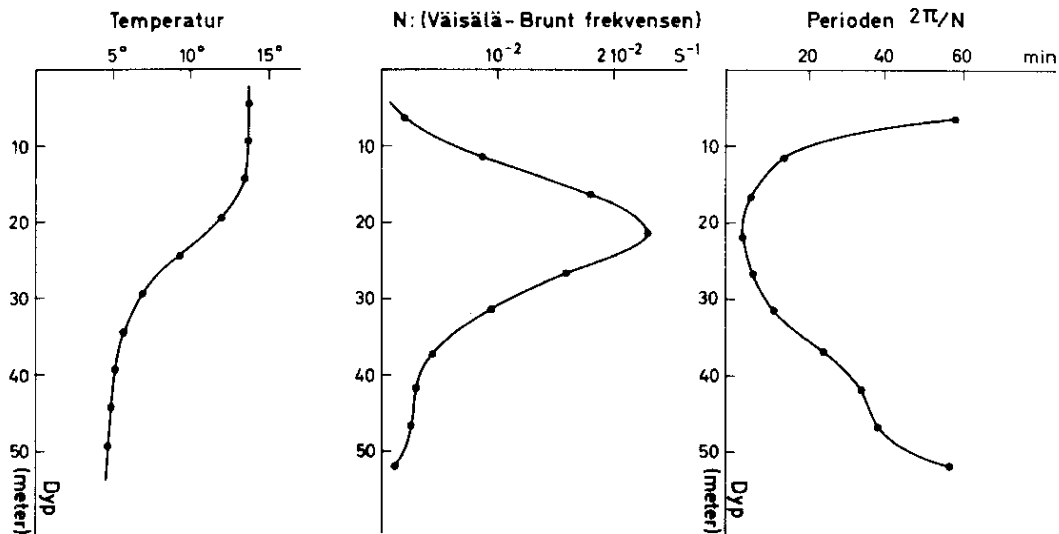

Figure 6.3: Målinger fra Hamarbukta i Mjøsa 4–9 september 1974.

på tilsvarende måte som i sprangsjiktet i havet. Dette kan gi opphav til indre tyngdebølger, og skipsbølgemønsteret ved Jan Mayen (figur 5.6) oppstår gjerne i slike situasjoner. I atmosfæren må man også ta hensyn til luftens kompressibilitet og vindvariasjonen i høyden. Disse problemene er inngående behandlet av Miles (1969), Gill (1983) og i GARP publication series (1980).

Vi skal her vise noen karakteristiske egenskaper for indre bølger knyttet til sprangsjiktet. Vi antar at N er en funksjon av z og søker løsninger av (6.7) som beskriver plane bølger som forplanter seg horisontalt

$$w(x, z, t) = \hat{w}(z) \sin(kx - \omega t) \quad (6.11)$$

og ved innsetting finner vi

$$\frac{d^2 \hat{w}}{dz^2} = -k^2 \left(\frac{N^2}{\omega^2} - 1 \right) \hat{w}. \quad (6.12)$$

Løsninger av denne likningen for forskjellige modeller av sprangsjiktet er beskrevet av Krauss (1966) og Roberts (1975). Likningen er av samme form som (4.5), og for store k kan for eksempel WKB-metoden benyttes til å finne tilnærmede løsninger. For $\omega < N$ har løsningen av (6.12) karakter tilsvarende harmoniske svingninger, mens for $\omega > N$ vil løsningen tilsvare en eksponensiell demping (eller økning). I sprangsjiktet kan vi derfor ha bølgebevegelse med vertikalhastighet som antydnet i figur 6.4.

De høyere moder (mode 3, 4 osv.) er karakterisert med flere svingninger innen området hvor $\omega < N$. For en bestemt verdi av ω hører en bestemt verdi av bølgetallet (egenverdi) slik at den laveste mode har det minste bølgetallet og den

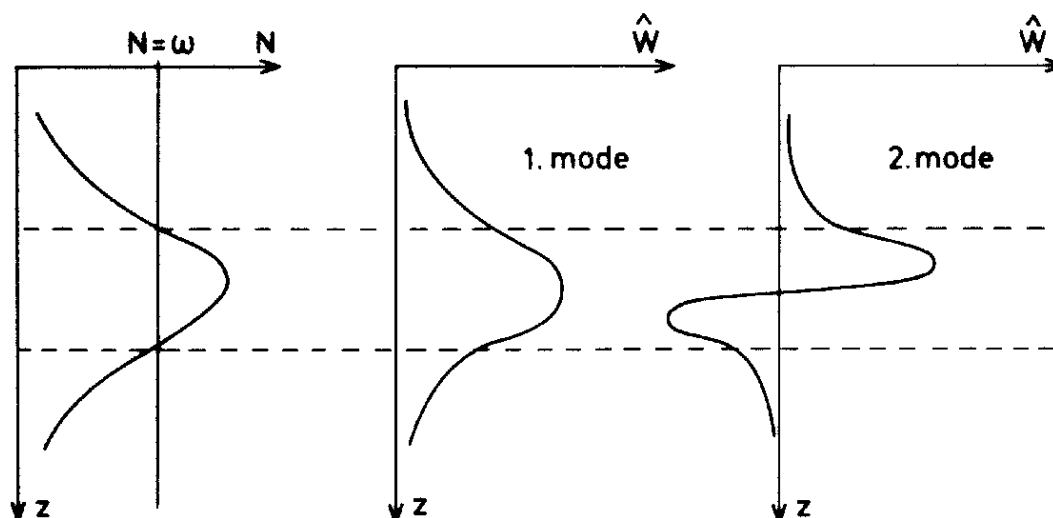

Figure 6.4:

største bølgelengde. Bølgelengden avtar gradvis for de øvrige modene. Bølger i mode 1 har den største forplantningshastigheten i horisontalretning. Til mode 1 og 2 tilsvarer en deformasjon av sprangsjiktet som antydnet i figur (6.5).

De største vertikalhastighetene i bølgebevegelsen finner en i nærheten av sprangsjiktet, og vertikalhastigheten er ubetydelig ved overflaten. Hevning eller senkning av overflaten vil derfor være ubetydelig selv om hevingen av sprangsjiktet kan være flere meter.

I tilfeller med et grunt sprangsjikt kan indre bølger fremkalle relativt store strømvariasjoner på overflaten. Strømsetningene vil virke inn på korte overflatebølger, med den følge at under lette vindforhold vil små bølger ha en tendens til å samles i bånd som altså avspeiler de indre bølger. Disse båndene kan noen ganger være synlig med det blotte øye. Siden refleksjon av radarbølger fra overflaten avhenger sterkt av overflatens ruhet, kan båndene bli ekstra godt synlig med radar. Et eksempel på et slikt “radar-bilde” av indre bølger er vist på figur (6.6).

Exercises

1. I tilfeller med markert sprangsjikt av liten vertikal utstrekning, kan sjiktningen tilnærmes ved en 2-lags modell med uniform tetthet $\rho_0 - \Delta\rho_0$ og ρ_0 henholdsvis i øvre og nedre lag. Tykkelsen av øvre og nedre lag betegnes henholdsvis med h og H . Bestem dispersjonsrelasjonen og hastighetsfeltet for plane bølger i denne modellen, og vis at bevegelsen har to moder; en overflatebølge-mode og en intern mode knyttet til skilleflaten. Vis at for lange bølger så er fasehastigheten for overflate-moden og den interne moden

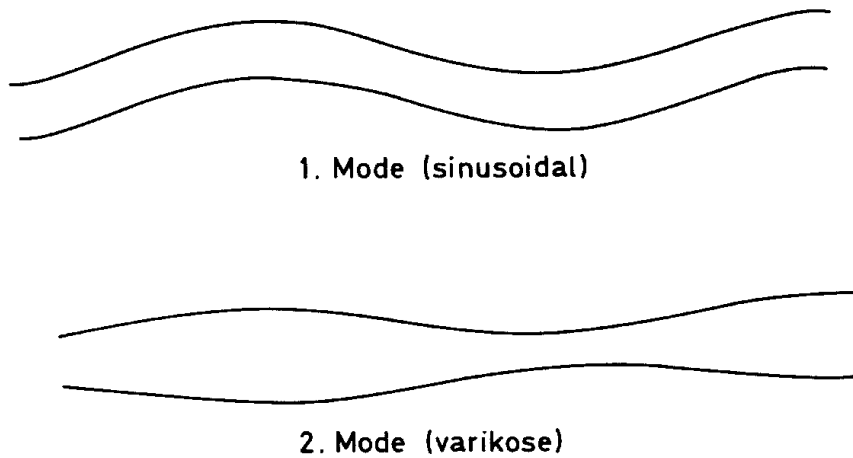

Figure 6.5:

henholdsvis

$$c = \sqrt{g(H+h)} \quad \text{og} \quad c = \sqrt{\frac{g^* H h}{H+h}}$$

hvor

$$g^* = \frac{\Delta\rho}{\rho_0} g$$

2. Bestem vertikalhastighet, og finn dispersjonsrelasjonen for indre tyngdebølger i et horisontalt væskelag med uniform dybde H . Tettheten ved likevekt øker eksponensielt med dypet (z)

$$\rho_0(z) = \rho_s e^{-\beta z}$$

hvor ρ_s er tettheten ved overflaten. Vi antar at vertikalhastigheten er null både ved overflaten og ved bunnen.

3. Lange bølger på et sprangsjikt

Vi har en friksjonsfri væske med to lag som ikke er blandbare. Videre antar vi at trykket i væsken er hydrostatisk, med null trykk på fri overflate og at bevegelsen foregår i et vertikalt plan. Ved $t = 0$ er horisontalkomponenten av hastigheten uavhengig av den vertikale koordinaten. Vi lar h_1 og h_2 være tykkelsene av øvre og nedre lag ved likevekt. η_1 og η_2 er vertikalforskyvningene av fri overflate og skilleflaten, og u_1 og u_2 er horisontalkomponentene av hastighetene i øvre og nedre lag. Tyngdens akselerasjon er g , og den relative tetthetsforskjellen mellom lagene er $\epsilon = \frac{\rho_2 - \rho_1}{\rho_2}$. Bevegelsen vil da

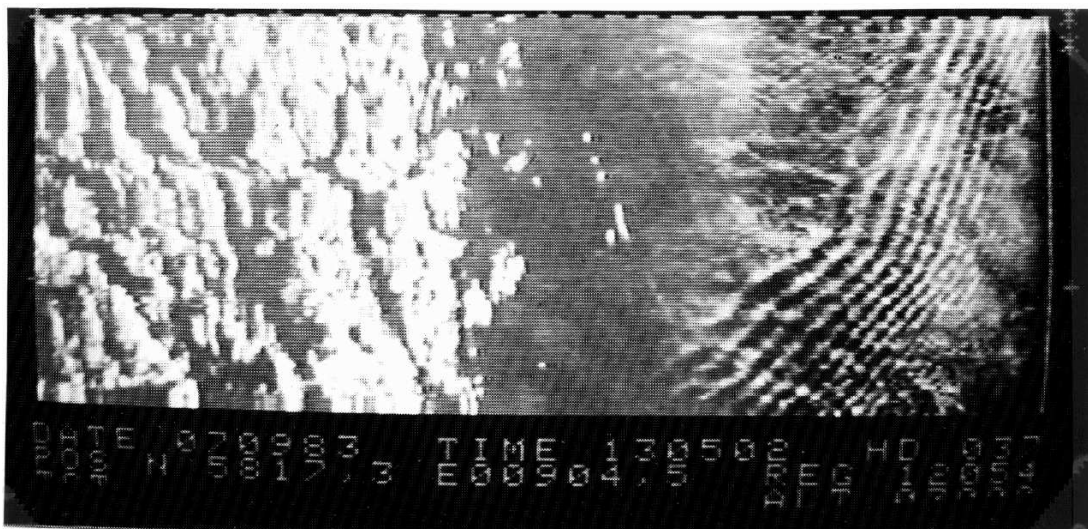

Figure 6.6: Radar-ekko fra havoverflaten i et område 10–15 km fra land sør-øst for Ryvingen mellom Grimstad og Arendal. Bildet ble tatt den 7. september 1983 av et fly som brukes i oljevernberedskaper. Båndstrukturen gjenspeiler indre bølger med bølgelengder fra 0.5–1 km. Nærmere analyse finnes i en artikkel av Gjevik og Høst (1984). (Foto Fjellanger Widerøe A/S).

være styrt av følgende ligninger:

$$\begin{aligned}\frac{\partial u_1}{\partial t} + u_1 \frac{\partial u_1}{\partial x} &= -g \frac{\partial \eta_1}{\partial x}, \\ \frac{\partial u_2}{\partial t} + u_2 \frac{\partial u_2}{\partial x} &= -g(1 - \epsilon) \frac{\partial \eta_1}{\partial x} - g\epsilon \frac{\partial \eta_2}{\partial x}, \\ \frac{\partial}{\partial t}(\eta_1 - \eta_2) &= -\frac{\partial}{\partial x}((h_1 + \eta_1 - \eta_2)u_1), \\ \frac{\partial \eta_2}{\partial t} &= -\frac{\partial}{\partial x}((h_2 + \eta_2)u_2).\end{aligned}$$

- (a) Utled disse ligningene. Hva innebærer antagelsen om hydrostatisk trykk?

Anta i resten av oppgaven at vi har flat bunn og små utslag fra likevekt.

- (b) Finn de harmoniske bølgeløsningene ligningssettet har. Vis at de faller i to klasser, og diskuter egenskapene de to modene har.
- (c) Ligningssettet har løsninger i form av pulser som går med uendret form. Vis at vi har to moder av disse pulsene, som tilsvarer modene i (b). Vis ved hjelp av noen enkle skisser hvordan forskyvningen av overflaten og skilleflaten avhenger av parametrene i problemet. Illustrerer også grafisk hvordan bølgehastigheten avhenger av disse parametrene.

Chapter 7

NONLINEAR WAVES

Vi har til nå hovedsaklig behandlet lineære bølger som er bølgebevegelse beskrevet ved lineære differensiallikninger. Disse likningene er som regel fremkommet ved at de ikke-lineære leddene i grunnlikningene er sløyfet. Dette kan gjøres under forutsetning av at bølgeamplituden er tilstrekkelig liten. Ved å bruke relasjoner som gjelder for de lineære bølgene har vi estimert størrelsen av de ikke-lineære leddene og funnet betingelser for når disse leddene kan sløyfes i forhold til de lineære ledd i likningene. I avsnitt 2.2 fant vi at for bølger på dypt vann kan de ikke-lineære leddene sløyfes dersom $a/H \ll 1$. Her betegner a , H og λ som før henholdsvis bølgeamplitude, midlere vanddyb og bølgelengde.

Vi skal nå se litt nærmere på bølgebevegelse hvor amplituden er så stor at de ikke-lineære leddene må beholdes i de likninger som beskriver bølgebevegelsen. Vi skal betegne slike bølger *ikke-lineære bølger*. Ikke-lineære bølger har på mange måter andre egenskaper enn lineære bølger. For ikke-lineære bølger gjelder:

1. Bølgehastigheten avhenger av amplituden.
2. Bølgebrytning kan inntreffe, og bølger med steil front (sjokkbølger) kan oppstå.
3. Bølgebevegelse kan sette opp en svak strøm i bølgenes forplantningsretning.
4. Forskjellige bølgekomponenter som samtidig forplanter seg gjennom samme område, vil påvirke hverandre. Superposisjonsprinsippet gjelder vanligvis ikke for ikke-lineære bølger.

Gjennom en del eksempler skal vi demonstrere disse effektene, og vi skal dessuten studere noen ikke-lineære bølgetyper som kan forplante seg med uendret form.

7.1 Ikke-lineære bølger på grunt vann. Riemann's løsningsmetode. Bølgebrytning.

Det følger av diskusjonen i avsnitt 2.10 at dersom Ursell-parameteren $\frac{u}{H}(\frac{\lambda}{H})^2 \gg 10$, så kan man regne trykkfordelingen i lange bølger på grunt vann som hydrostatisk. Dersom man bare tar med de dominerende ikke-lineære ledd i bevegelseslikningen, får man at likningene (2.89) og (2.90) beskriver plane ikke-lineære bølger på grunt vann. I disse likningene inngår bare horisontalhastigheten u og overflatehevingen η som ukjente.

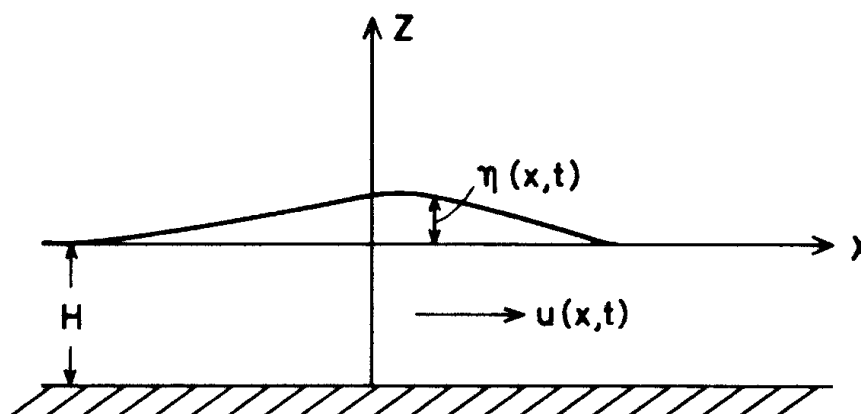

Figure 7.1:

Vi regner altså her med hydrostatisk trykkfordeling slik at hastigheten u kan betraktes som konstant gjennom væskelaget. Derved er u bare funksjon av x og t . Vi innfører nå størrelsen

$$c^2 = g(H + \eta) \quad (7.1)$$

og ved å eliminere η fra (2.89) og (2.90) får vi følgende likninger

$$\frac{\partial u}{\partial t} + u \frac{\partial u}{\partial x} = -2c \frac{\partial c}{\partial x},$$

$$\frac{\partial}{\partial t}(2c) + c \frac{\partial u}{\partial x} + u \frac{\partial}{\partial x}(2c) = 0.$$

Ved addisjon og substraksjon av disse to likningene finner vi

$$\left[\frac{\partial}{\partial t} + (c + u) \frac{\partial}{\partial x} \right] (2c + u) = 0 \quad (7.2)$$

$$\left[\frac{\partial}{\partial t} - (c - u) \frac{\partial}{\partial x} \right] (2c - u) = 0 \quad (7.3)$$

De opprinnelige likningene er derved brakt over på en form slik at likningene kan løses ved hjelp av karakteristikk. Dette går under navnet Riemann's metode

fordi Riemann (1892) foretok en liknende transformasjon av likningene for ikke-lineære lydbølger i en gass slik at han kunne diskutere løsningen av likningene. Likningene for ikke-lineære lydbølger kan nemlig skrives på tilsvarende form som (7.2) og (7.3), slik at det er en direkte analogi mellom ikke-lineære lydbølger og ikke-lineære vannbølger på grunt vann.

Likningen (7.2) viser at størrelsen

$$P = 2c + u = \text{konstant} \quad (7.4)$$

langs kurver (karakteristikker) i (x,t) -planet hvor vinkelkoeffisienten til kurvene er bestemt ved

$$\frac{dx}{dt} = c + u. \quad (7.5)$$

Vi betegner disse kurvene med C^+ . Likeledes viser (7.3) at størrelsen

$$Q = 2c - u = \text{konstant} \quad (7.6)$$

langs kurver med vinkelkoeffisient

$$\frac{dx}{dt} = -(c - u) \quad (7.7)$$

og vi betegner disse kurvene med C^- .

La oss anta at ved $t = 0$ er u og c spesifisert som funksjon av x . I et hvert punkt på x -aksen bestemmer da (7.5) og (7.7) vinkelkoeffisienten for to kurver C^+ og C^- . Langs disse kurvene er henholdsvis størrelsene P og Q bevart. Velger man

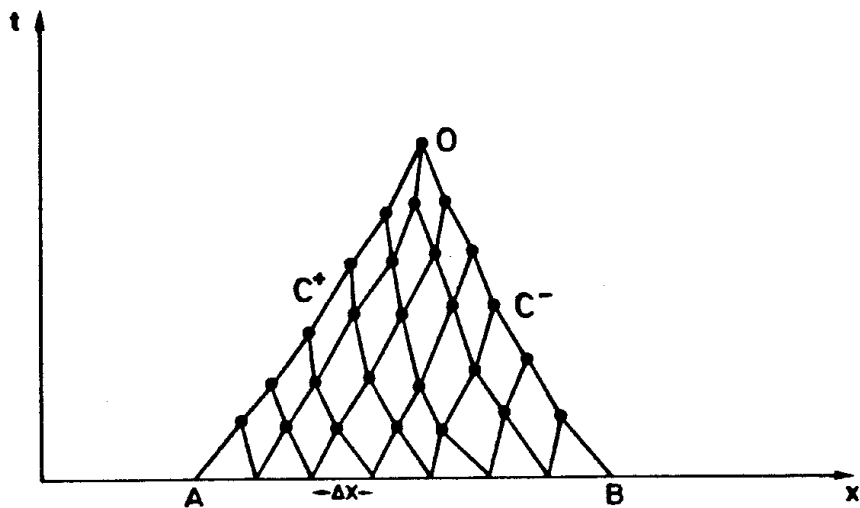

Figure 7.2:

punkter på x -aksen som ligger i en tilstrekkelig liten avstand Δx fra hverandre, kan kurvene approksimeres med rette linjer i tangentretningene. I skjæringspunktene for C^+ og C^- linjene kan man så bestemme verdiene av u og c . Derved kan man bestemme vinkelkoeffisienten for kurvene i skjæringspunktene slik at disse igjen kan tjene som utgangspunkter for beregningen av u og c i nye punkt. Gridnettet ved en slik numerisk integrasjon er skissert på figur 7.2. Gjennom ethvert punkt er det bare tegnet to karakteristikk fordi vi forutsetter her at u og c skal være entydige i punktene. På figuren skjærer C^+ karakteristikken gjennom A og C^- karakteristikken gjennom B hverandre i punktet O . Verdien av u og c i punktet O er således bare bestemt av den initielle forstyrrelse i området AB på x -aksen. Vi sier at O har AB som avhengighetsområde.

La oss anta at ved tiden $t = 0$ er overflaten som følge av en eller annen forstyrrelse løftet over likevektsstillingen innenfor et område AB og at væskelaget er i ro og den øvrige delen av overflaten er uforstyrret. I (x, t) -planet vil karakteristikkene i dette tilfellet gå som antydnet på figur 7.3. For enkelthets skyld har vi her bare tegnet de karakteristikkene som går gjennom A og B som i dette tilfellet vil være rette linjer. I et visst tidsrom avhengig av formen på forstyrrelsen, vil karakteristikkene gjennom A og B begrense knippene av C^+ og C^- karakteristikker som stråler ut fra området AB .

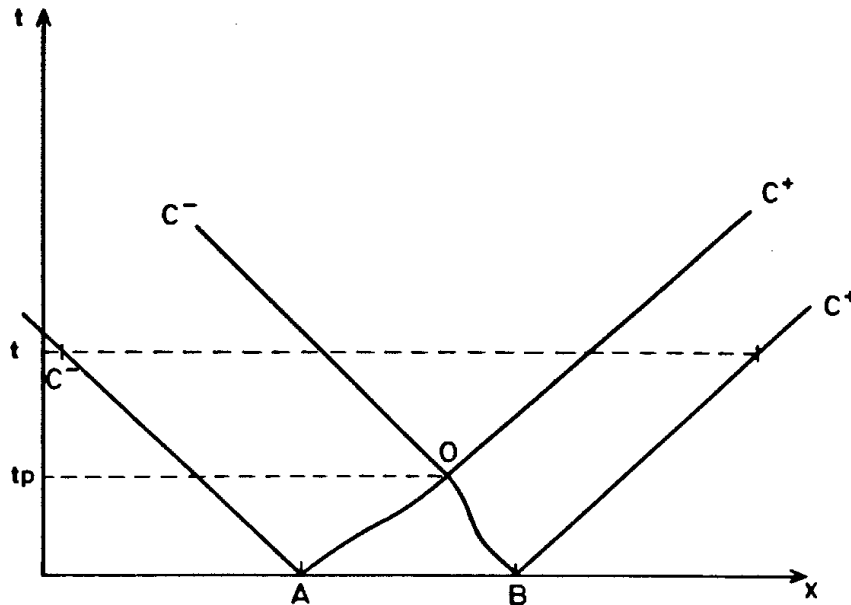

Figure 7.3:

Etter et tidsrom t_p skjærer C^- karakteristikken gjennom B og C^+ karakteristikken gjennom A hverandre i punktet O . Ved et senere tidspunkt $t > t_p$ er knippene av C^+ og C^- karakteristikker adskilt. Dette betyr at den opprinnelige

forstyrrelsen ved $t = 0$ er splittet opp i to adskilte bølger som beveger seg henholdsvis mot høyre og venstre. Mellom de to bølgene er væsken i ro, og overflaten er plan.

For $t > t_p$ skjærer knippet av C^+ karakteristikk fra AB C^- karakteristikk som kommer fra området utenfor AB . Innenfor det knippet som representerer bølgen som beveger seg mot høyre er følgende

$$Q = 2c - u = 2c_0 \quad (7.8)$$

hvor $c_0 = \sqrt{gH}$. Punktet på bølgen beveger seg mot høyre med hastighet

$$c_f = c + u.$$

Ved hjelp av (7.8) og (7.1) kan vi skrive

$$c_f = 3c - 2c_0 = c_0[3\sqrt{1 + \eta/H} - 2]. \quad (7.9)$$

Dersom $\eta/H \ll 1$, har vi at

$$c_f \simeq c_0[1 + \frac{3}{2}\frac{\eta}{H}]. \quad (7.10)$$

Uttrykkene (7.9) og (7.10) viser at bølgen beveger seg med en hastighet avhengig av den relative bølgeamplituden η/H . I dette tilfellet hvor $\eta/H > 0$, vil bølgetoppen bevege seg raskere enn resten av bølgen. Dette vil medføre at bølgen etterhvert utvikler en bratt front slik som skissert i figur 7.4.

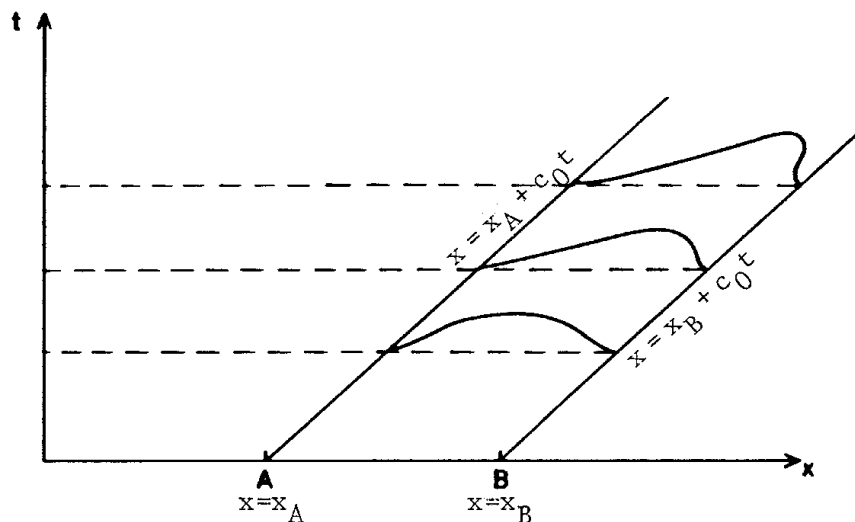

Figure 7.4:

Etter en viss tid t_b vil bølgefronten være steil med vertikal tangent, og etter dette vil bølgen bryte. Ved brytning vil bølgeformen være en flertydig funksjon av

x , og matematisk gir dette seg utslag i at flere karakteristikk skjærer hverandre i et punkt. Forutsetningen om at bare to karakteristikk, en C^+ og en C^- karakteristikk skjærer hverandre i hvert punkt i (x, t) -planet, innebærer derfor at vi betrakter bølgebevegelse før brytning inntreffer. I avsnitt 7.3 skal vi se nærmere på bølgeformer som kan oppstå etter at brytning har inntruffet.

7.2 Korteweg-de Vries equation. Nonlinear waves with permanent form. Solitons.

A portion of the important properties of long waves in shallow water can be summed up by three simple model equations. We choose to look at waves which propagate in the x -axis direction. Then the equation

$$\frac{\partial \eta}{\partial t} + c_0 \frac{\partial \eta}{\partial x} = 0 \quad (7.11)$$

where $c_0 = \sqrt{gH}$, describes linear non-dispersive waves. The equation has the solution $\eta = f(x - c_0 t)$ where f is an arbitrary function. The wave moves with constant velocity and unchanging form. The equation

$$\frac{\partial \eta}{\partial t} + c_0 \frac{\partial \eta}{\partial x} + \frac{c_0 H^2}{6} \frac{\partial^3 \eta}{\partial x^3} = 0 \quad (7.12)$$

describes in the first approximation, linear dispersive waves. The equation has the solution $\eta = A e^{ik(x-ct)}$ where $c = c_0(1 - \frac{(kH)^2}{6})$. This is in agreement with what we have found in section 2.1 for long waves in shallow water after having corrected for the deviation from the hydrostatic pressure distribution. Further, the equation

$$\frac{\partial \eta}{\partial t} + c_0(1 + \frac{3}{2} \frac{\eta}{H}) \frac{\partial \eta}{\partial x} = 0 \quad (7.13)$$

will in the first approximation describe nonlinear waves which propagate with a velocity which depends on amplitude in correspondence with what we have found in section 7.1. Equation (7.13) expresses therefore that the wave form changes and develops a steep front if $\eta/H > 0$. By combining equations (7.12) and (7.13), in the first approximation, one gets an equation that incorporates both dispersion and non-linear effects. This is the Korteweg-de Vries equation (KdV equation).

$$\frac{\partial \eta}{\partial t} + c_0(1 + \frac{3}{2} \frac{\eta}{H}) \frac{\partial \eta}{\partial x} + \frac{c_0 H^2}{6} \frac{\partial^3 \eta}{\partial x^3} = 0. \quad (7.14)$$

The KdV equation can be derived from the equations of motion by a formal series expansion where the parameters a/H and $(H/\lambda)^2$ contain the generation parameters. Here we shall suffice with the intuitive and minimally stringent derivation which is described above. By this method we find that nevertheless

emphasize an important thing. A differential equation of the KdV type will be valid for all wave types where nonlinearity and dispersion are of the special form described here. The KdV equation for waves in shallow water was first derived by Korteweg and de Vries (1895). It has been also shown that the equations can emerge from long waves in other media such as plasma in a magnetic field.

In section 2.10 we found that the dispersion term which comes from deviations from the hydrostatic pressure distribution is of the same order of magnitude as the dominant nonlinear term if the Ursell parameter $\frac{a}{H}(\frac{\lambda}{H})^2$ is around 10. In this case, we can expect that nonlinearity and dispersion will balance each other such that nonlinear waves will arise which propagate with constant velocity and unchanging form. To investigate this we seek a solution of the KdV equation of the form

$$\eta = H\zeta(\psi)$$

where ζ is a function of $\psi = (x - Ut)/H$. Setting into the KdV equation we find

$$\zeta''' + [6(1 - \frac{U}{c_0}) + 9\zeta]\zeta' = 0$$

where the mark ' denotes the derivation with respect to ψ . By integrating

$$\zeta'' + 6(1 - \frac{U}{c_0})\zeta + \frac{9}{2}\zeta^2 = \text{konstant.}$$

we shall now assume that ζ , ζ' and $\zeta'' \rightarrow 0$ for $\psi \rightarrow \infty$. The constant of integration can be set to zero, and by multiplying the last equation with ζ' and integrating we find

$$\zeta'^2 = 3\zeta^2(\alpha - \zeta) \quad (7.15)$$

where

$$\alpha = 2(\frac{U}{c_0} - 1) \quad (7.16)$$

Equation (7.15) has the solution

$$\zeta = \alpha \operatorname{sech}^2[(\frac{3\alpha}{4})^{\frac{1}{2}}\psi] \quad (7.17)$$

where $\operatorname{sech} z = 1/\cosh z$. The surface displacement which corresponds to (7.17) is sketched in figure 7.5 for $\alpha = 0.5$. The figure shows a symmetric wave form established by a single wave crest. The wave has the amplitude αH , and moves with velocity

$$U = c_0(1 + \frac{\alpha}{2}).$$

Because of this, waves of this form are called *solitary waves*. They can be generated in a wave channel, propagate unchanging for long distances, and reflect from the end wall in the channel. The KdV equation also has a solution

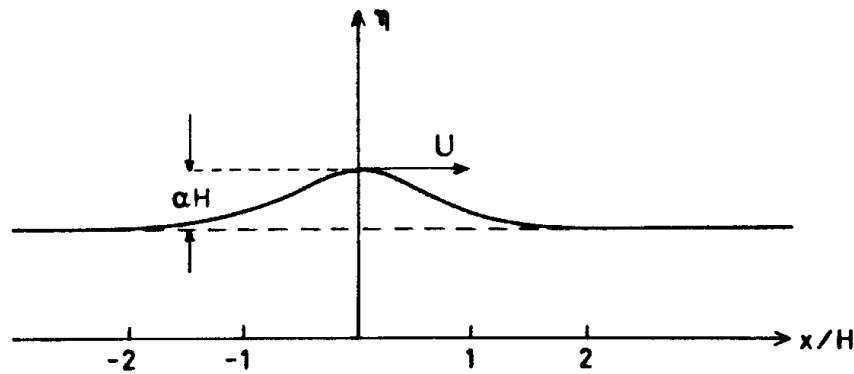

Figure 7.5:

which corresponds to periodic waves which propagate with unchanging form and constant velocity. These waves are called *cnoidal waves*. They consist of steep wave crests separated by extended wave troughs.

The solitary wave and the cnoidal wave have been known for a long time, both of which have solutions from the KdV equation and from experiment. In recent times, there has been a series of discoveries that have renewed the interest in these wave phenomena. Through theoretical work, the KdV equation has been successfully transformed into a form which makes it possible to discuss other solutions of the equation. One has, amongst another discoveries, that two solitary waves that propagate towards each other will collide and then reappear as solitary waves moving from each other. There are other important wave phenomena which are also described by the KdV equation such as in quantum mechanics, optics, and in crystal lattices. Even if the base equation is different from the KdV equation, one has found solutions with properties equivalent to the solitary wave. The common designation for waves of this description is *soliton*.

7.2.1 Mer om solitoner

Enkle og idealiserte bølgeløsninger spiller en stor rolle i bølgeteori. Delevis skyldes dette at disse løsninger ofte kan sees som deler av mer komplekse bølgemønstre. En annen viktig grunn er at studiet av spesielle løsninger kan gi generell innsikt i oppførselen til bølger og de fysiske mekanismene som er involvert.

I litteraturen er bølger av *permanent form* viktige. Som navnet antyder er dette bølger som forplanter seg med uendret form og konstant hastighet. Naturligvis opptrer slike løsninger eksakt bare for uniforme medier, men ofte vil de også gi en god tilnærming når mediet varierer langsomt. Det enkleste, og viktigste, eksemplet på bølger av permanent form er den enkle harmoniske moden (“sinusbølge”) som vi finner i lineær bølgeteori. Det finnes også en del ikke-lineære bølger av permanent form, bl.a.: Stokes-bølgen som er en generalis-

ering av den harmoniske moden, sjokk av endelig utstrekning i diffusive media og solitære bølger som vi skal omtale her. Som navnet antyder består en solitær bølge av en enkelt bølgetopp. I streng forstand har den ikke endelig utstrekning, men styrken (avviket fra likevekt) forsvinner når vi fjerner oss fra toppen. Dersom solitærbølger oppfyller bestemte interaksjonsrelasjoner kalles de solitoner. Grovt sagt kreves et at de overlever kollisjoner uten tap av identitet eller samlet energi etc.

Solitære bølger ble, sammen med mange andre bølgefenomener, først beskrevet av J. Scott Russel i hans banebrytende arbeid "Report on Waves" som ble forfattet på oppdrag fra The Royal Society in London i 1842. Scott Russel var britisk vannveis-ingeniør og gjorde mange observasjoner av bølger i kanaler, deriblandt av en enkelt (solitær) bølgetopp som forplantet seg over lange avstander uten merkbar formendring eller oppsplitting. Han klarte også å gjenskape en slik bølge i laboratoriet og målte dens hastighet til å være $\sqrt{g(h+A)}$ der g er tyngdens akselerasjon, h dypet ved likevekt og A amplituden.

Den første som ga en komplett teoretisk beskrivelse av solitærbølgen var J. Boussinesq i 1871. Det var i forbindelse med dette arbeidet han utledet den opprinnelige Boussinesq likningen. Senere har mer nøyaktige uttrykk for solitærbølgen blitt funnet fra perturbasjonsutviklinger anvendt direkte på det fulle likningsettet for en ideell væske. En har også funnet helt andre typer av solitærbølger. De solitærbølger som er av samme natur som den lange overflatebølgen kalles i dag ofte for Boussinesq-soliton.

Forskning på solitærbølger kom svært i skuddet på 60-tallet. Basert på den enkle KdV likningen ble det utviklet en omfattende teori omkring disse bølgene. En fant forbløffende interaksjonsegenskaper mellom solitærbølger som er analoge til støt mellom partikler, noe som ga en forbindelse over til kvantefysikken. Ved den såkalte inverse spredningsteorien kunne man forutsi mye om hvordan solitoner kan utvikle seg fra initialbetingelser av generell form. Senere har man funnet en del andre spesielle fenomener der solitærbølger er, eller kan være, involvert. Disse skal vi la ligge og heller konsentrere oss om de sidene ved solitærbølgen som allerede er nevnt.

7.3 Vannstandssprang. Hydraulisk sjokk.

Dersom dispersjonen er for svak til å forhindre brytning, kan det utvikle seg bølgeformer med steil front og med kraftig turbulent bevegelse i en sone nær fronten. Forøvrig vil bølgen bevege seg med konstant hastighet og med uendret form. Slike bølgeformer kan man iaktta i naturen for eksempel i overløpsrenner fra demninger og i elver hvor vannet renner med stor hastighet. Bølgen kan da opptre som et stasjonært *vannstandssprang* blant ujevnheter i bunnen.

I enkelte elver, blant annet Severn River i England og Tsien-Tang i Kina, forplanter tidevannet seg oppover elva i form av et vannstands-sprang med kraftig

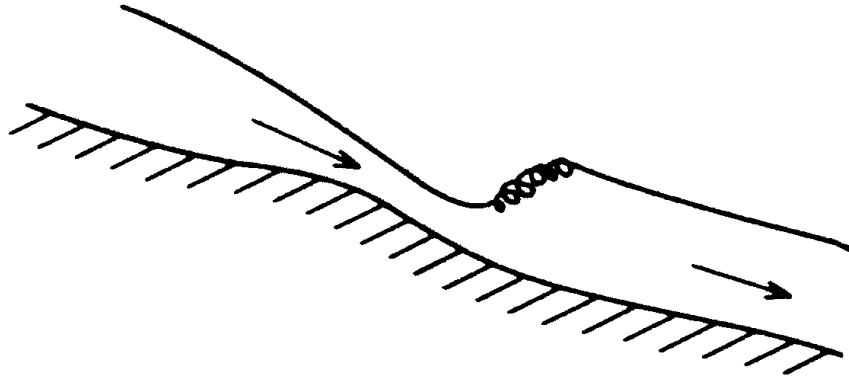

Figure 7.6:

turbulens i spranget og med tilnærmet plane vannflater foran og bak spranget.

Vi skal her beskrive en enkel modell av vannstandssprang, og vi skal representere selve spranget ved en diskontinuerlig overgang mellom to vann-nivåer h_1 og h_2 , og vi velger $h_1 < h_2$ slik som vist på figur 7.7.

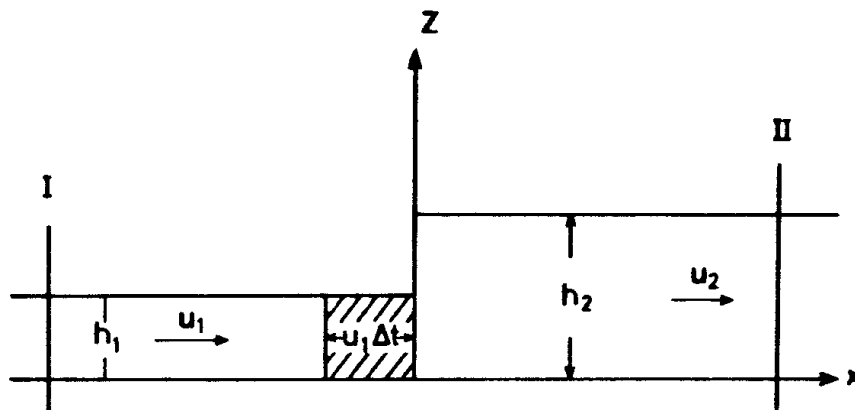

Figure 7.7:

I første omgang vil vi betrakte et stasjonært vannstandssprang, og vi vil forutsette at strømhastigheten er konstant på hver side av spranget. Vi betegner strømhastigheten ved u_1 og u_2 som angitt på figuren. Siden spranget er stasjonært og u_1 og u_2 er uavhengige av z , er volumfluksen

$$Q = u_1 h_1 = u_2 h_2. \quad (7.18)$$

Vi benytter så impulslikningen på væskevolumet mellom de to vertikale snittflatene I og II som angitt på figuren. Netto innstrømming av bevegelsesmengde

gjennom snittflatene må være lik differansen i trykk-kraft ved de to flatene. Under forutsetning om hydrostatisk trykkfordeling får vi

$$\rho u_2^2 h_2 - \rho u_1^2 h_1 = -\frac{1}{2}\rho g h_2^2 + \frac{1}{2}\rho g h_1^2$$

hvor ρ er tettheten i væsken. Ved hjelp av (7.18) kan den siste likningen skrives

$$Q(u_2 - u_1) = \frac{g}{2}(h_1^2 - h_2^2). \quad (7.19)$$

Av (7.18) og (7.19) finner vi Q , u_1 og u_2 uttrykt ved h_1 og h_2 .

$$\begin{aligned} Q^2 &= \frac{g}{2} h_2 h_1 (h_1 + h_2) \\ u_1 &= c_1 \sqrt{\frac{1}{2} \left(\frac{h_2}{h_1}\right) \left(1 + \frac{h_2}{h_1}\right)} \\ u_2 &= c_2 \sqrt{\frac{1}{2} \left(\frac{h_1}{h_2}\right) \left(1 + \frac{h_1}{h_2}\right)} \end{aligned} \quad (7.20)$$

hvor $c_1 = \sqrt{gh_1}$ og $c_2 = \sqrt{gh_2}$. Vi ser av (7.21) at for $h_1 < h_2$ så er $u_1 > c_1$ og $u_2 < c_2$. Strømhastigheten er altså større enn forplantningshastigheten for lange lineære bølger på forsiden av spranget, og strømhastigheten er mindre enn den tilsvarende forplantningshastigheten på baksiden av spranget.

Vi skal nå se på energiregnskapet for et væskevolum som passerer spranget. I løpet av et tidsrom Δt passerer en væskemengde $Q\Delta t$ spranget. Samtidig utfører trykket et netto arbeid på væskemengden som kan skrives

$$\Delta W = \frac{1}{2}\rho g Q \Delta t (h_1 - h_2).$$

Før væskemengden passerer spranget har den en mekanisk energi

$$\left(\frac{1}{2}\rho g u_1^2 + \frac{1}{2}\rho g h_1\right) Q \Delta t$$

og etter at hele væskemengden har passert spranget, har den en mekanisk energi

$$\left(\frac{1}{2}\rho g u_2^2 + \frac{1}{2}\rho g h_2\right) Q \Delta t.$$

Tar man hensyn til det utførte arbeidet, finner en fort at for væskemengden som passerer spranget så er endringen i indre energi

$$\Delta E = \frac{\rho}{2} Q \Delta t [u_1^2 - u_2^2 - 2g(h_2 - h_1)].$$

Ved hjelp av formlene (7.21) får vi at endringen i ΔE pr. tidsenhet er

$$\frac{\Delta E}{\Delta t} = \frac{\rho g}{4} \frac{Q}{h_1 h_2} (h_2 - h_1)^3. \quad (7.21)$$

Dette betyr at dersom $h_2 > h_1$, så er det en økning av væskens indre energi, og et tilsvarende tap av væskens mekaniske energi må finne sted. Denne overføringen av mekanisk energi til indre energi kan komme i stand ved turbulent dissipasjon, og derfor er vannstandssprang karakterisert ved kraftig turbulent bevegelse i en sone nær spranget. Ved å frembringe vannstandssprang i overløpsrenner og kanaler, kan man på en effektiv måte redusere strømhastigheten. Denne teknikk blir mye brukt i vannbygg. Energitapet kan også komme i stand ved at den frigjorte energien transporteres vekk fra spranget ved bølger. En vil da ha et *bølgende vannstandssprang* med bølger på overflaten bak spranget, slik at den modellen vi har studert her ikke kan anvendes. Bølgende vannstandssprang kan frembringes ved eksperiment og observeres i naturen, f.eks. i Severn River.

Av (7.21) ser vi at for $h_1 > h_2$ må væsken som passerer spranget tilføres energi, og et vannstandssprang av denne type er derfor umulig.

Om vi legger en hastighet $-u_1$ til den bevegelsen som vi har beskrevet ovenfor, får vi at et vannstandssprang som forplanter seg inn i et vannlag som er i ro. Forplantningshastigheten for vannstandsspranget vil da være u_1 hvor u_2 er gitt ved (7.21).

Til slutt skal vi bare nevne at vannstandssprang er en hydraulisk analogi til sjokkbølger i gasser. En benytter derfor noen ganger betegnelsen *hydraulisk sjokk* om vannstandsspranget.

Bibliography

- [1] Farmer, D.M. & Freeland, H.J. (1983), The Physical Oceanography of Fjords. *Progr. in Oceanography* 12, 2, 147–215.
- [2] GARP publication (1980), Orographic effects in planetary flows. GARP-publ. series No. 23 WMO, Geneva.
- [3] Gill, A.E. (1982), *Atmosphere–Ocean Dynamics*. Academic Press, London.
- [4] Gjertveit, E. (1971), Numerical calculations of long periodic oscillations at two Norwegian harbours. *Proc. Sec. Int. Conf. Port Ocean Eng., Arctic Conditions*, Vol. II, 751–771.
- [5] Gjevik, B. og Høst, S.E. (1984), Langkammede indre bølger i Skagerrak. *Naturen* 6, 209–214.
- [6] Gjevik, B., Lygre, A. & Krogstad, H.E. (1984), Ocean swell on the Norwegian continental shelf. Report 6201/1/84 IKU, Oceanographic Center, Trondheim, Norway.
- [7] Gjevik, B. (1981), *Innføring i fluidmekanikk. Forelesninger*, Matematisk institutt, Universitetet i Oslo.
- [8] Kinsman, B. (1965), *Wind waves*. Prentice Hall Inc., Englewood Cliffs, New Jersey.
- [9] Lamb, H. (1932), *Hydrodynamics*, Sixth edition, Dover Publications, New York.
- [10] Lighthill, J. (1978), *Waves in fluids*. Cambridge University Press, London.
- [11] Miles, J.W. (1974), Harbor seiching. *Ann. Rev. Fluid Mech.* Vol. 6, Annual Reviews Inc. Palo Alto, California.
- [12] Miles, J.W. (1969), Waves and wave drag in stratified flows. *Proc. 12th Intern. Congr. Appl. Mech.*, Stanford University 26–31 August 1968.

- [13] Mørk, G., Gjevik, B. & Holte, S. (1979), Generation and propagation of long internal waves in Mjøsa. Innsjøers dynamikk. Intern report nr. 2, Norsk Hydrologisk komite, Oslo.
- [14] Newman, J.N. (1977), Marine Hydrodynamics. The MIT Press, Cambridge, Massachusetts.
- [15] Palm, E. (1953), On the formation of surface waves in a fluid flowing over a corrugated bed and on the development of mountain waves. *Astrophys. Norvegica*, V, 3, 61–130.
- [16] Peregrine, D.H. (1976), Interaction of Water Waves and Currents. *Adv. Appl. Mech.*, 16, 9–17.
- [17] Rottmann, K. (1960), *Mathematische Formelsammlung*.
- [18] Stoker, J.J. (1957), *Water Waves*, Interscience Publishers Inc., New York.
- [19] Thorpe, S.A., Hall, A. & Crofts, I. (1972), The internal surge in Loch Ness. *Nature* 237, No. 5350, 96–98.
- [20] Tolstoy, I. (1973), *Wave propagation*, McGraw-Hill, New York.
- [21] Viggoson, G. & Rye, H. (1971), Long periodic oscillations in Sørvær harbour, Finnmark, Norway.
- [22] Whitham, G.B. (1974), *Linear and nonlinear waves*. John Wiley & Sons, New York.